

FRONT ELEVATION

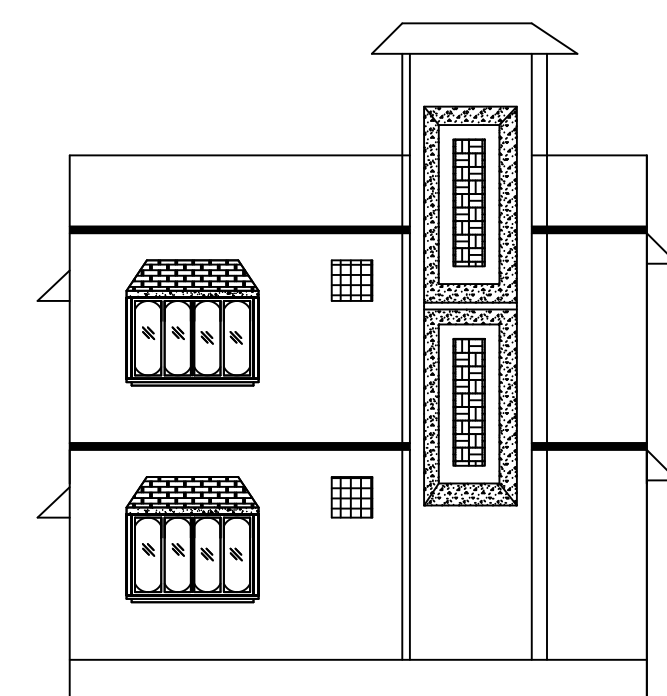

LEFT SIDE ELEVATION

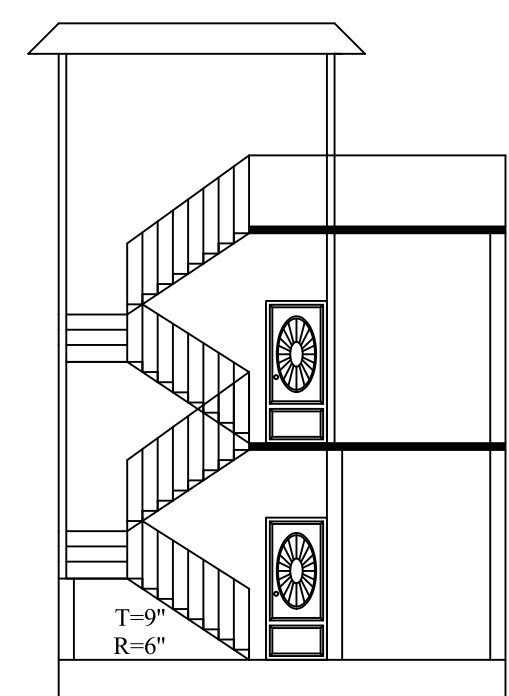

SECTION ON XX

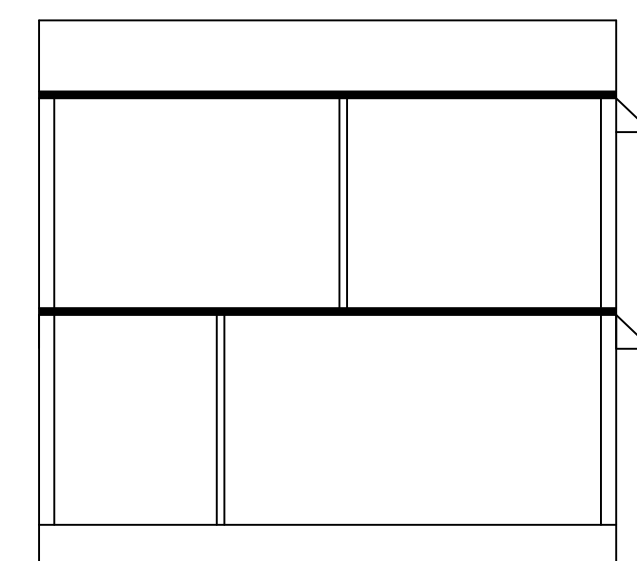

SECTION ON YY

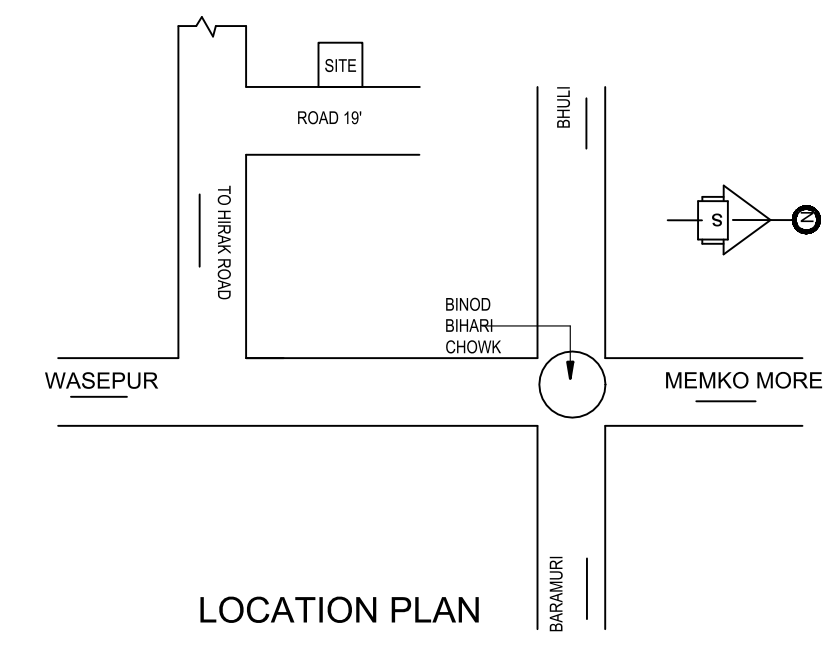

LOCATION PLAN

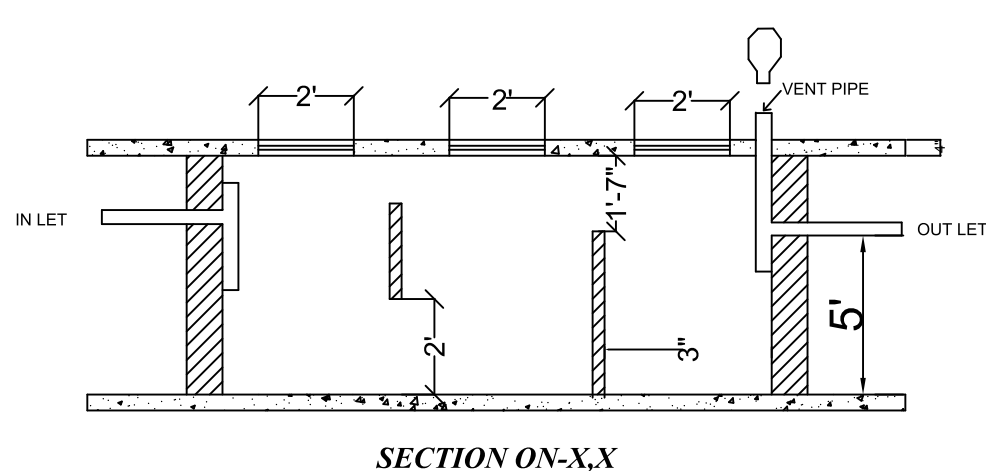

SECTION ON XX

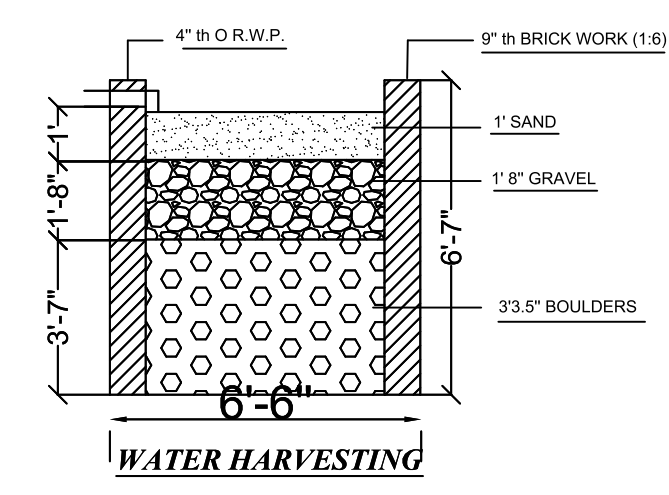

WATER HARVESTING

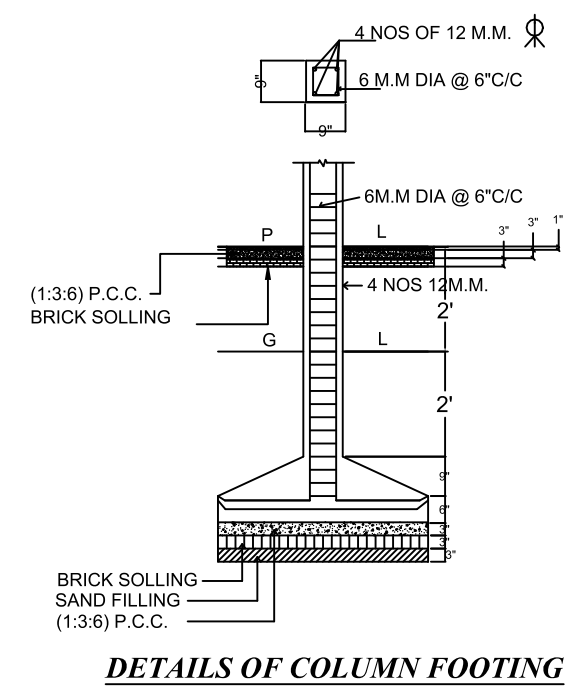

DETAILS OF COLUMN FOOTING

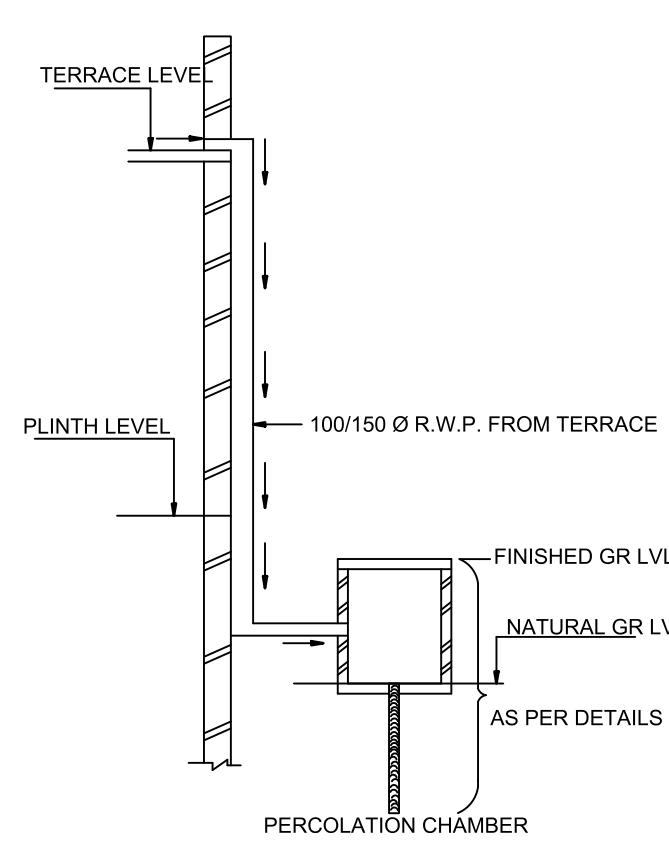

ROOF TOP RAIN WATER COLLECTION SYSTEM

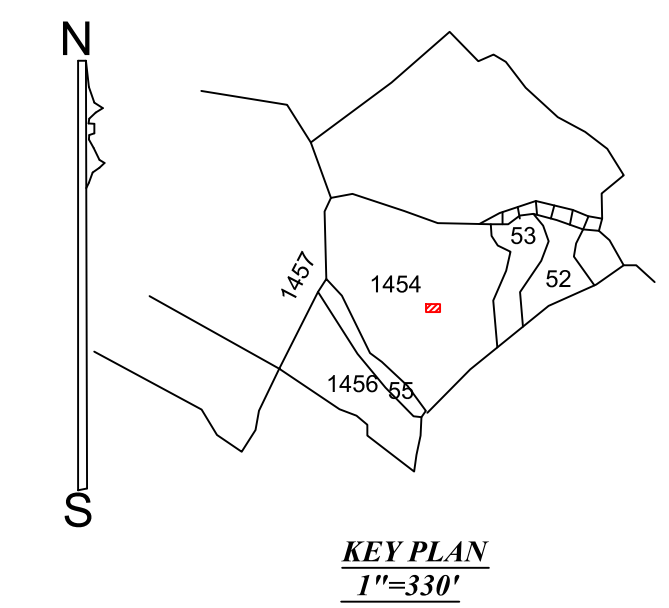

KEY PLAN
1"=330'

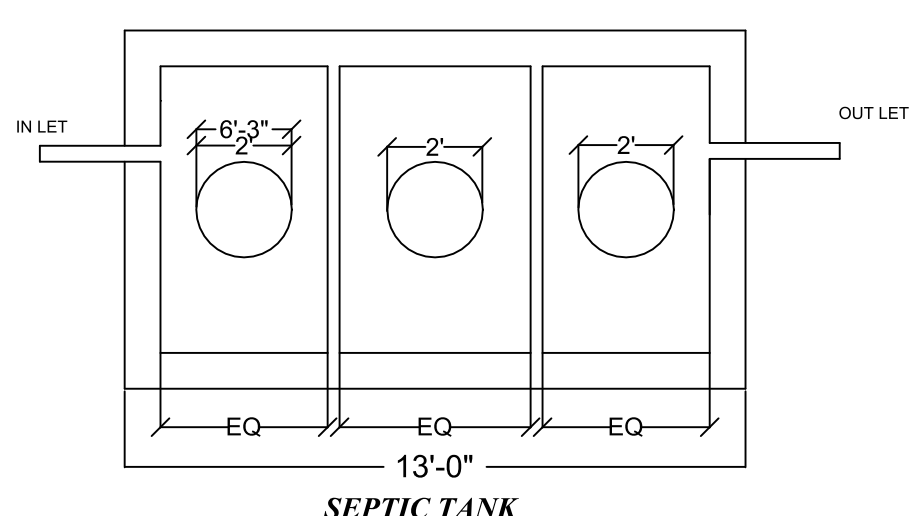

SEPTIC TANK

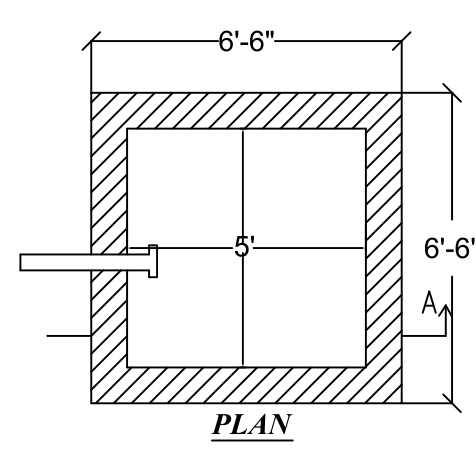

PLAN

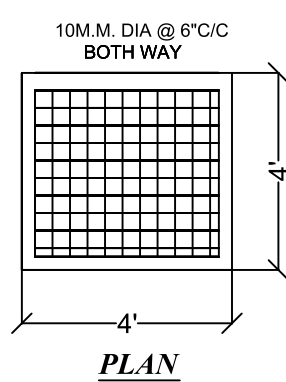

PLAN

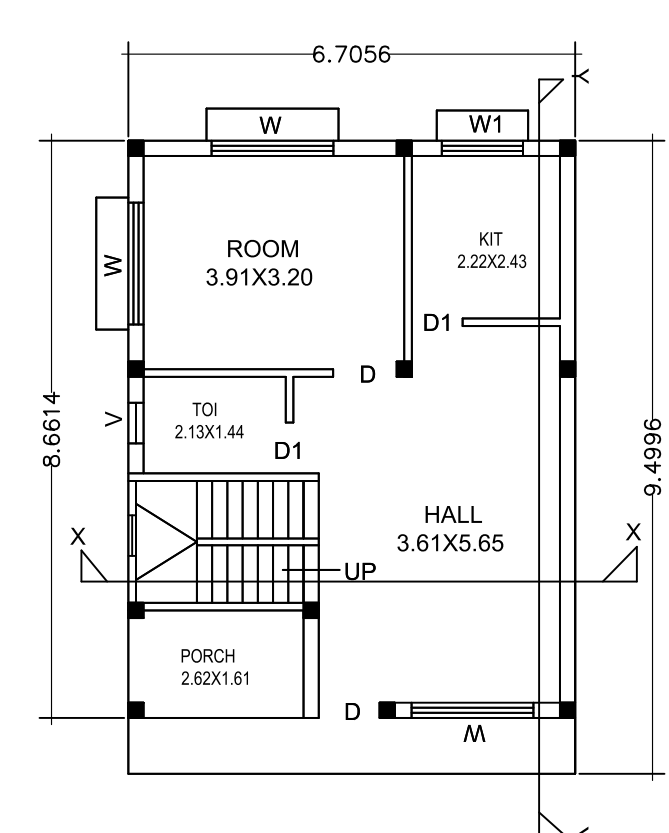

GROUND FLOOR PLAN

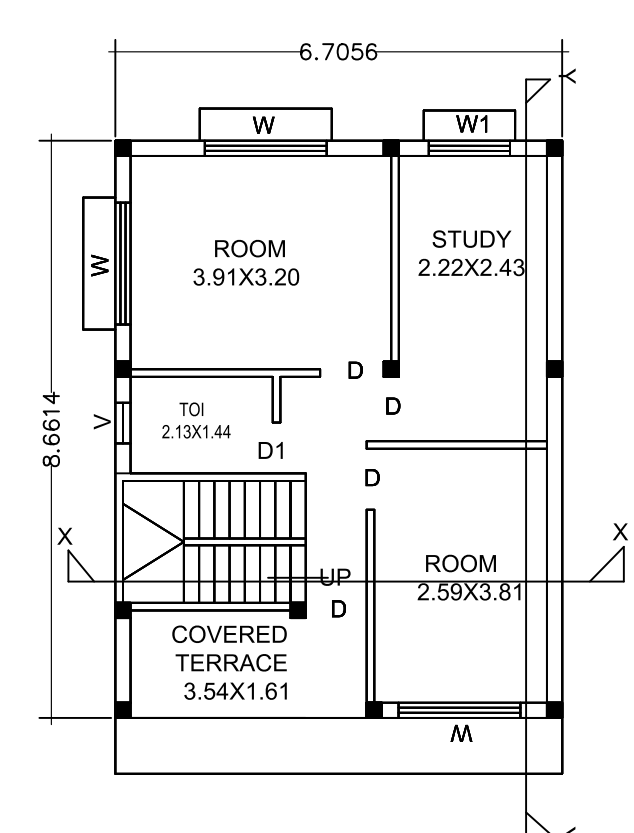

1ST FLOOR PLAN

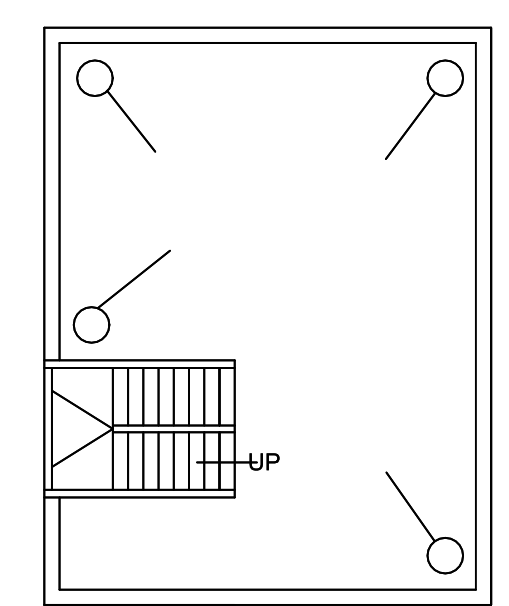

TERRACE FLOOR

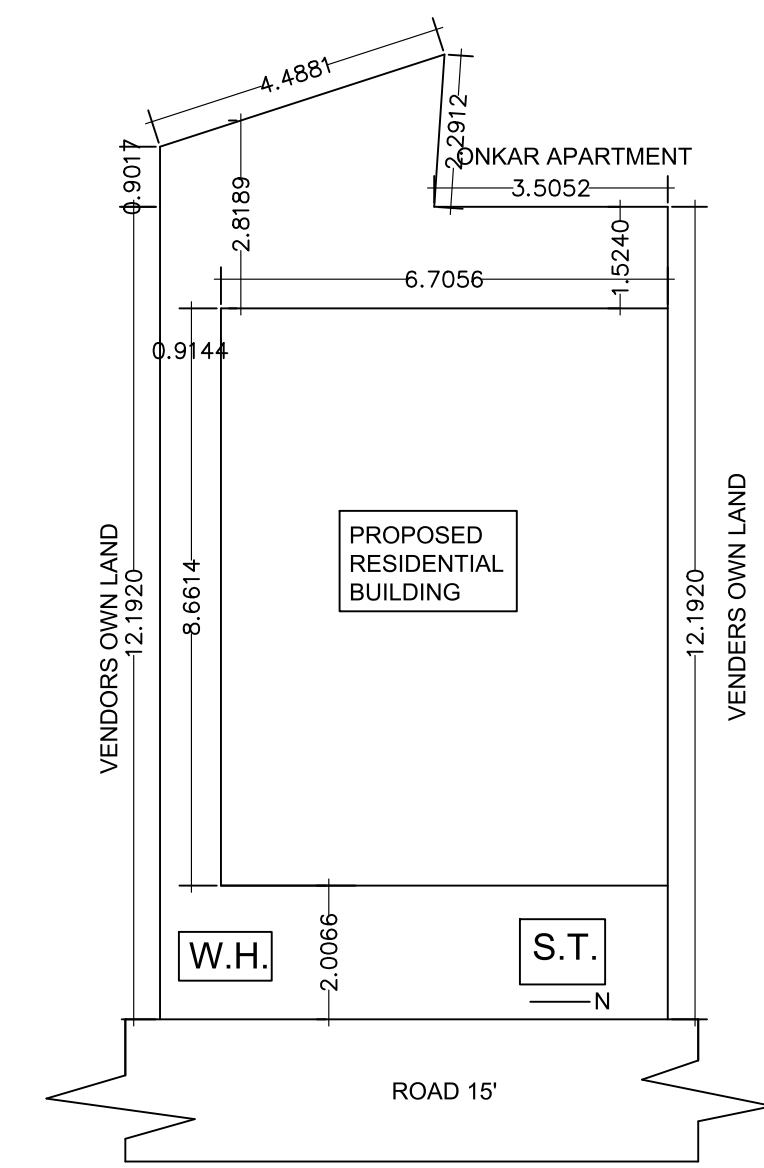

SITE PLAN
1"=8'

BRIEF SPECIFICATION

FOUNDATION :- R,C,C, (1:1.5:3) Column footing foundation.
PLINTH :- 12"th R.C.C. (1:1.5:3) all round on plinth level
FLOORING :- 1.5"th I.P.S flooring over 3"th P.C.C. (1:3:6)
SUPER STRUCTURE :- First class brick work in cement mortar (1:6).
SLAB,BEAM & LINTEL :- All R.C.C. work (1:1.5:3).
WOOD WORK :- All door & window frames are of sal wood and shutter. 12m,m thick
PLASTERING :- 6.m,m thick cement plaster (1:6) in both side.

SCHEDULE

D1 - 2'6" X 7'0"	W - 6'0" X 4'0"
D - 3'6" X 7'0"	W1 - 4'0" X 4'0"
	V - 2'0" X 2'0"

DETAILS OF AREA

AVAI LAND AREA (AS PER DEED)	99.58 sqmt
AVAI LAND AREA (AS PER SITE)	99.56 sqmt
PLINTH AREA	58.07 sqmt
FIRST FLOOR AREA	58.07 sqmt
TOTAL BUILTUP AREA	116.14 sqmt
% PLINTH AREA	58.32 %
F.A.R.	1.16

TITLE OF DRAWING

PROPOSED RESIDENTIAL BUILDING PLAN OF SMT. MANI DEVI W/O LATE ARVIND KUMAR OJHA, MOUZA IN NAWADIH NO. 02, OLD KHATA NO. 74, NEW KHATA NO. 64, OLD PLOT NO. 1454,1455,1456 NEW PLOT NO.1633. AREA- 2.46 DECIMAL, LOT NO. 19 (DIST-DHANBAD)

SIG. OF OWNER

SIG. OF ENGINEER

(Er. SANTOSH)
HI-TECH ASSOCIATES
 22,UNION-CLUB MARKET
 LUBY CIRCULAR ROAD
 DHANBAD

ALL DIMENTION ARE IN INTCH/FIT.
 SCALE-1"=8'