

SITE PLAN

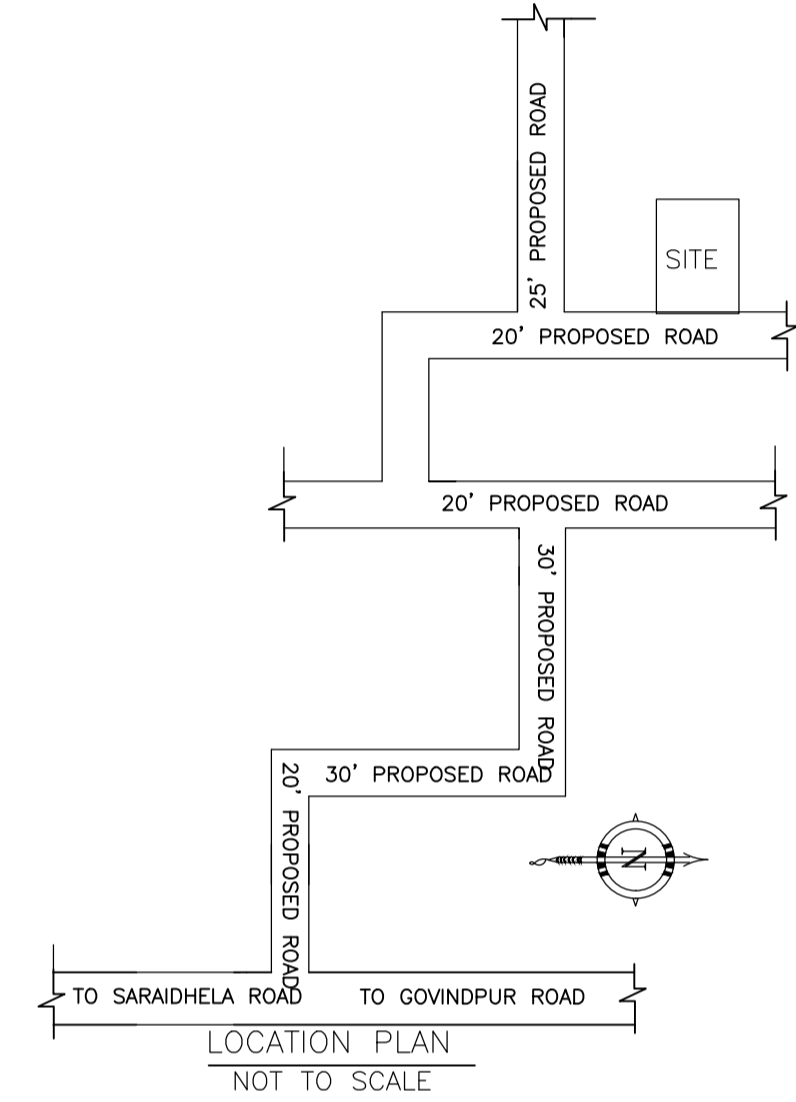
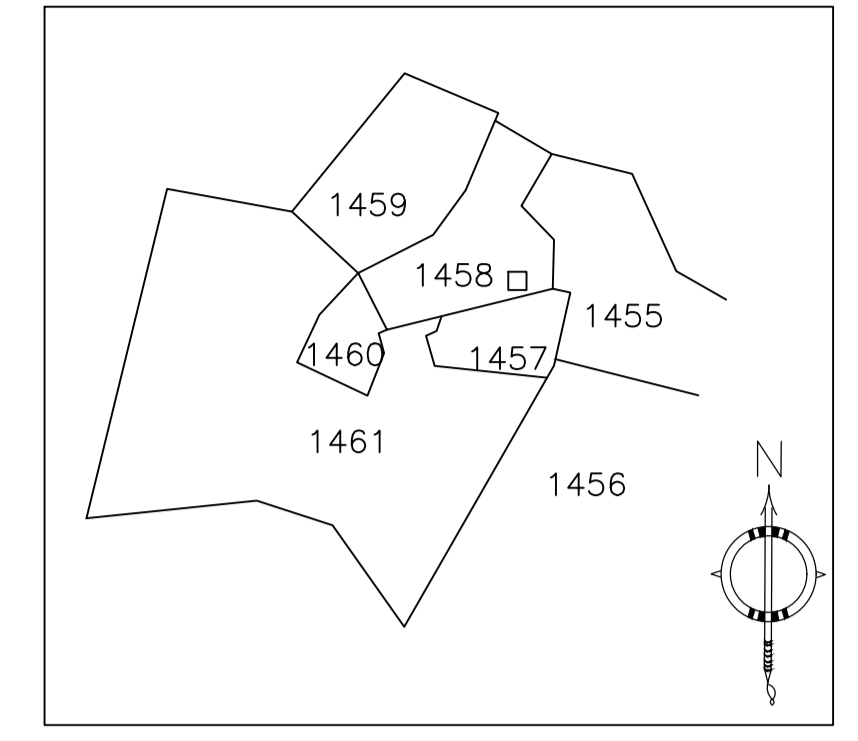

Building :RESI (ANAND)

Floor Name	Total Built Up Area (Sq.mt.)	Proposed FAR Area (Sq.mt.)	Total FAR Area (Sq.mt.)	Total Consumed Additional FAR Area (Sq.mt.)	Tnmt (No.)
Ground Floor	81.94	81.94	81.94	81.94	01
First Floor	81.94	81.94	81.94	81.94	00
Terrace Floor	0.00	0.00	0.00	0.00	00
<b>Total:</b>	<b>163.88</b>	<b>163.88</b>	<b>163.88</b>	<b>163.88</b>	<b>01</b>

SCHEDULE OF DOOR:

BUILDING NAME	NAME	LENGTH	HEIGHT	NOS
RESI (ANAND)	D	0.76	2.10	02
RESI (ANAND)	D	0.79	2.10	01
RESI (ANAND)	D	0.91	2.10	01
RESI (ANAND)	D	0.93	2.10	01
RESI (ANAND)	D	0.97	2.10	01
RESI (ANAND)	D	1.00	2.10	01
RESI (ANAND)	D	1.07	2.10	04
RESI (ANAND)	D	1.52	2.10	01

SCHEDULE OF WINDOW/VENTILATION:

BUILDING NAME	NAME	LENGTH	HEIGHT	NOS
RESI (ANAND)	W	0.84	1.20	03
RESI (ANAND)	W	1.22	1.20	01
RESI (ANAND)	W	1.52	1.20	10
RESI (ANAND)	W	2.55	1.20	02

UnitBUA Table for Building :RESI (ANAND)

FLOOR	Name	UnitBUA Type	UnitBUA Area	Carpet Area	No. of Rooms	No. of Tenement
GROUND FLOOR PLAN	SPLIT 1	FLAT	163.88	163.22	6	1
FIRST FLOOR PLAN	SPLIT 1	FLAT	0.00	0.00	7	0
<b>Total:</b>	-	-	<b>163.88</b>	<b>163.22</b>	<b>13</b>	<b>1</b>

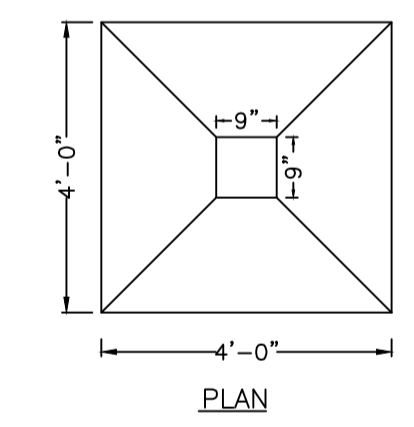
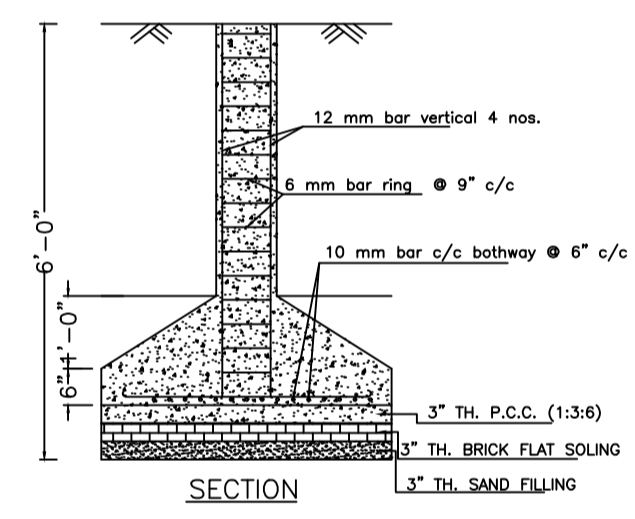
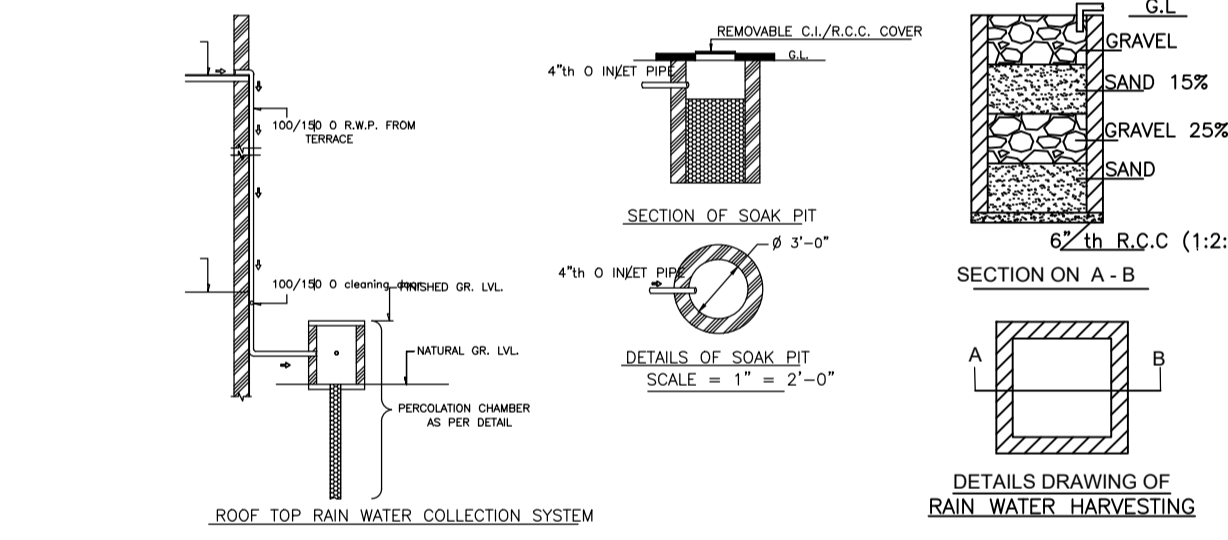

DETAILS OF COLUMN FOUNDATION

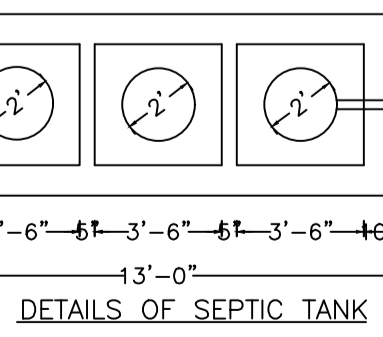
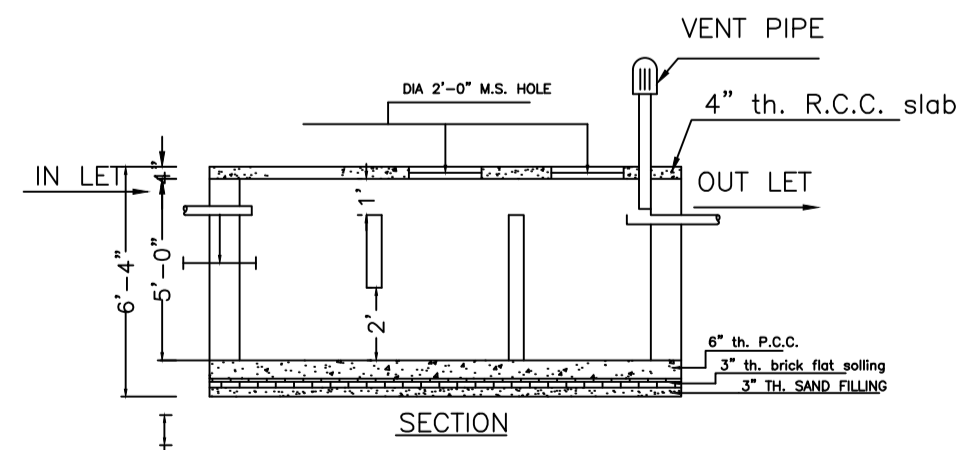

DETAILS OF SEPTIC TANK

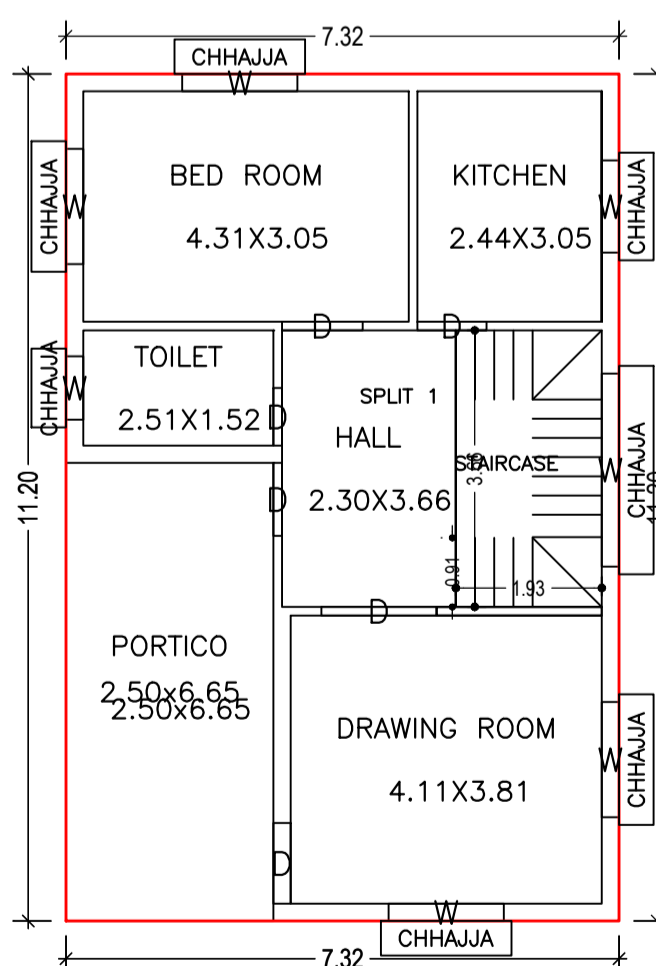

GROUND FLOOR PLAN (Proposed) (SCALE 1:100)

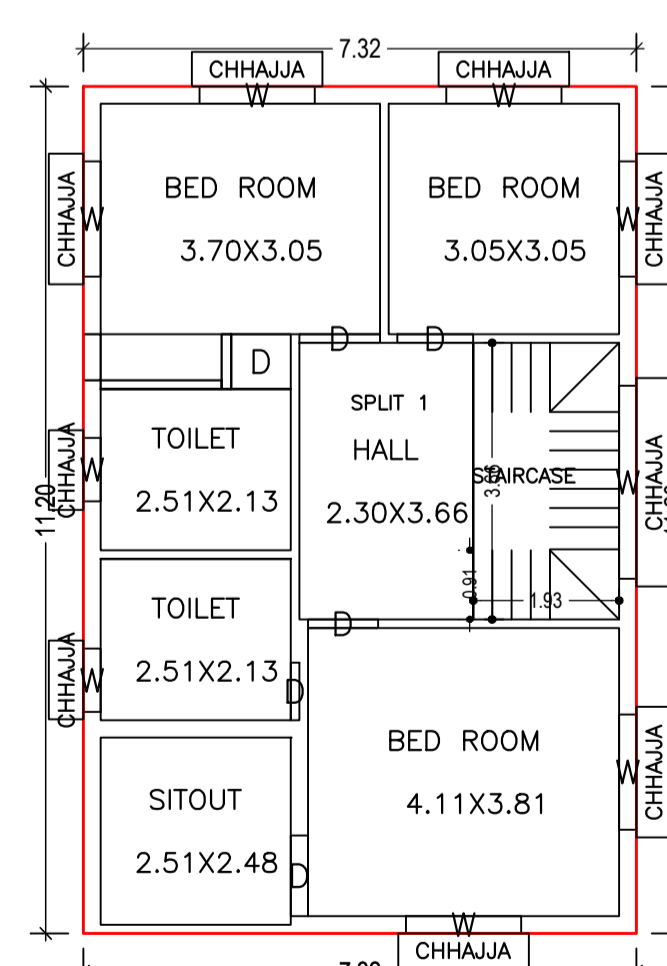

FIRST FLOOR PLAN (Proposed) (SCALE 1:100)

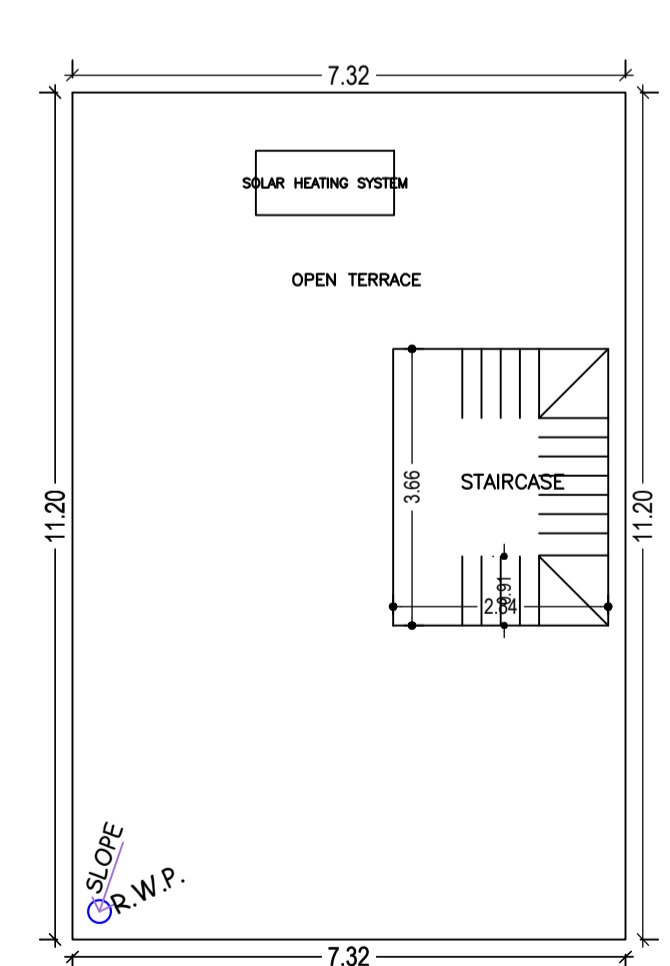

TERRACE FLOOR PLAN (SCALE 1:100)

Proposal Basic Information

Proposal File No.	MADA/BP/0109/2023
Owner Name	DR. ANAND KUMAR MISHRA
Khata No	OLD KHATA NO-34, NEW KHATA NO-5
Plot No	OLD PLOT NO-515, NEW PLOT NO-1458
Village Name	Jialgora
Use	Residential
SubUse	Bungalow/ Dwelling / Non Apartment

AREA STATEMENT MINERAL AREA DEVELOPMENT AUTHORITY

VERSION NO.:	1.0.66	
VERSION DATE:	16/10/2020	
PROJECT DETAIL:		
Region : JHARKHAND URBAN LOCAL BODIES	Plot Use: Residential	
District : DHANBAD	Plot SubUse: Bungalow/ Dwelling / Non Apartment	
Authority : MINERAL AREA DEVELOPMENT AUTHORITY	Plot/Nearby/Religious/Structure: NA	
Inward No: MADA/BP/0109/2023	Plot/SubPlot No: OLD PLOT NO-515, NEW PLOT NO-1458	
Application Type: General Proposal	North: Plot No. - SAME PLOT	
Project Type: Building Permission	South: Plot No. - SAME PLOT	
Nature of Development: New	East: Road Width - 6.10	
Location of Development Area: Old Area	West: Plot No. - SAME PLOT	
AREA DETAILS:		
AREA OF PLOT (Minimum)	(A)	SQ.MT.
NET AREA OF PLOT (Gross Plot Area - Deduction from Gross Plot area)	(A-Deductions)	138.97
Deduction for Balance Plot Area (from Gross Plot Area)		
Common Plot		
Total		11.76
BALANCE AREA OF PLOT (Net Plot Area - Recreational/Amenity space)	(A-Deductions)	127.21
PLOT AREA FOR COVERAGE (Net Plot Area)	(A-Deductions)	138.97
Plot Area for FAR (Net Plot Area + Road Widening Area)	(A-Deductions)	138.97
COVERAGE CHECK		
Permissible Coverage area ( 70.00 % )		97.28
Proposed Coverage Area ( 58.96 % )		81.94
Total Prop. Coverage Area ( 58.96 % )		81.94
Balance coverage area ( 11.04 % )		15.34
FAR CHECK		
Perm. FAR Area ( 2.500 )		347.42
Total Perm. FAR area		347.42
Residential FAR		163.88
Proposed FAR Area		163.88
Total Proposed FAR Area		163.88
Consumed FAR (Factor)		1.18
Balance FAR Area		183.54
BUILT UP AREA CHECK		
Total Proposed BuiltUp Area		163.88
ARCHITECT (Regd)		RAM PRATAP SINGH
ENGINEER (Regd)		
SUPERVISOR (Regd)		
OWNER (Regd)		DR. ANAND KUMAR MISHRA
DEVELOPMENT AUTHORITY		LOCAL BODY

COLOR INDEX

PLOT BOUNDARY	Black
ABUTTING ROAD	Green
PROPOSED CONSTRUCTION	Red
COMMON PLOT	Yellow
ROAD WIDENING AREA	Blue
EXISTING (To be retained)	Light Blue
EXISTING (To be demolished)	Dark Blue

Buildingwise Floor FAR Details

Floor Name	Building Name		Total	
	Proposed Built Up Area (Sq.mt.)	Proposed FAR Area (Sq.mt.)	Total Proposed Built Up Area (Sq.mt.)	Total FAR Area (Sq.mt.)
Ground Floor	81.94	81.94	81.94	81.94
First Floor	81.94	81.94	81.94	81.94
Terrace Floor	0.00	0.00	0.00	0.00
<b>Total :</b>	<b>163.88</b>	<b>163.88</b>	<b>163.88</b>	<b>163.88</b>

Building USE/SUBUSE Details

Building Name	Building Use	Building SubUse	Building Structure
RESI (ANAND)	Residential	Bungalow/ Dwelling / Non Apartment	Non-Highrise

FAR & Tenement Details (Table 4c-1)

Building	No. of Same Bldg	Total Built Up Area (Sq.mt.)	Proposed FAR Area (Sq.mt.)	Total FAR Area (Sq.mt.)	Total Consumed Additional FAR Area (Sq.mt.)	Tnmt (No.)
RESI (ANAND)	1	163.88	163.88	163.88	163.88	01
<b>Grand Total :</b>	<b>1</b>	<b>163.88</b>	<b>163.88</b>	<b>163.88</b>	<b>163.88</b>	<b>01</b>

LTP NAME AND SIGNATURE	STRUCTURAL ENG'S NAME AND SIGNATURE	BUILDER NAME AND SIGNATURE	DIGITAL SIGNATURE
RAM PRATAP SINGH MADA/ARC/0024/2019			