

Proposal Basic Information

Proposal File No.	MADA/BP/0153/2023
Owner Name	NISHAT BEGUM
Khata No	OLD KHATA NO-24, NEW KHATA NO-179
Plot No	OLD PLOT NO-1307, NEW PLOT NO-1150
Village Name	Kurmidi
Use	Residential
SubUse	Bungalow/ Dwelling / Non Apartment

AREA STATEMENT MINERAL AREA DEVELOPMENT AUTHORITY

VERSION NO.:	1.0.66	
VERSION DATE:	16/10/2020	
PROJECT DETAIL:		
Region: JHARKHAND URBAN LOCAL BODIES	Plot Use: Residential	
District: DHANBAD	Plot SubUse: Bungalow/ Dwelling / Non Apartment	
Authority: MINERAL AREA DEVELOPMENT AUTHORITY	PlotNearby/ReligiousStructure: NA	
Inward No: MADA/BP/0153/2023	Plot/SubPlot No: OLD PLOT NO-1307, NEW PLOT NO-1150	
Application Type: General Proposal	North: Plot No. - SAME PLOT	
Project Type: Building Permission	South: Plot No. - SAME PLOT	
Nature of Development: New	East: Plot No. - SAME PLOT	
Location of Development Area: Old Area	West: Road Width - 6.10	
AREA DETAILS:		
AREA OF PLOT (Minimum)	(A)	SQ.MT.
NET AREA OF PLOT (Gross Plot Area - Deduction from Gross Plot area)	(A-Deductions)	157.71
Deduction for Balance Plot Area (from Gross Plot Area)		
Total		18.79
BALANCE AREA OF PLOT (Net Plot Area - Recreational/Amenity space)	(A-Deductions)	138.92
PLOT AREA FOR COVERAGE (Net Plot Area)	(A-Deductions)	157.71
Plot Area for FAR (Net Plot Area + Road Widening Area)	(A-Deductions)	157.71
COVERAGE CHECK		
Permissible Coverage area (70.00 %)		110.40
Proposed Coverage Area (58.86 %)		92.82
Total Prop. Coverage area (58.86 %)		92.82
Balance coverage area (11.15 %)		17.58
FAR CHECK		
Perm. FAR Area (2.500)		394.28
Total Perm. FAR area		394.28
Residential FAR		185.65
Proposed FAR Area		185.65
Total Proposed FAR Area		185.65
Consumed FAR (Factor)		1.18
Balance FAR Area		208.63
BUILT UP AREA CHECK		
Total Proposed BuiltUp Area		185.64
ARCHITECT (Regd)		RAM PRATAP SINGH
ENGINEER (Regd)		
SUPERVISOR (Regd)		
OWNER (Regd)		NISHAT BEGUM
DEVELOPMENT AUTHORITY		
		LOCAL BODY

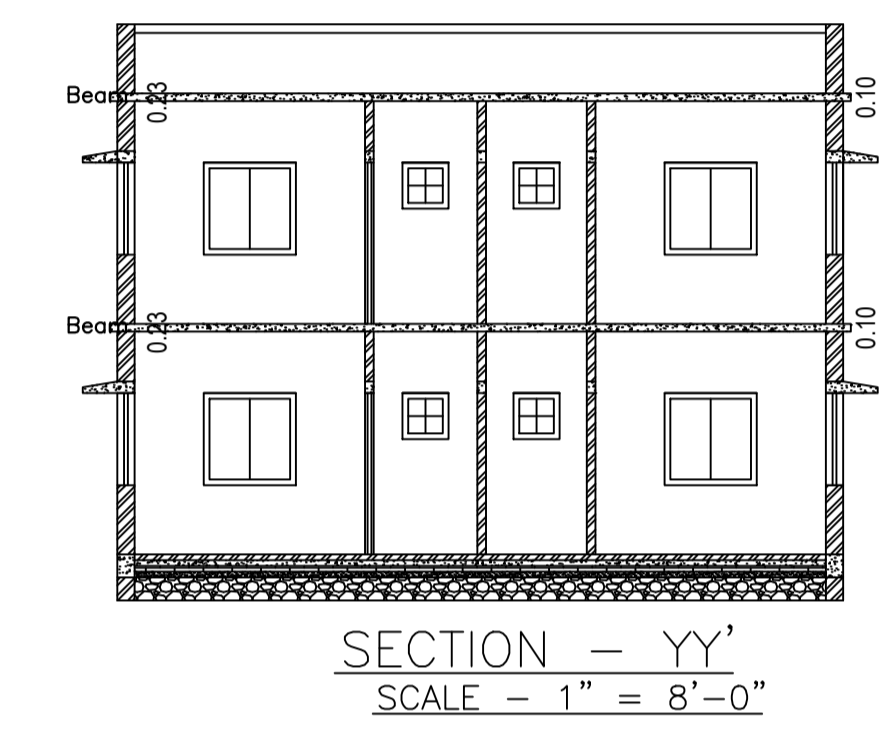
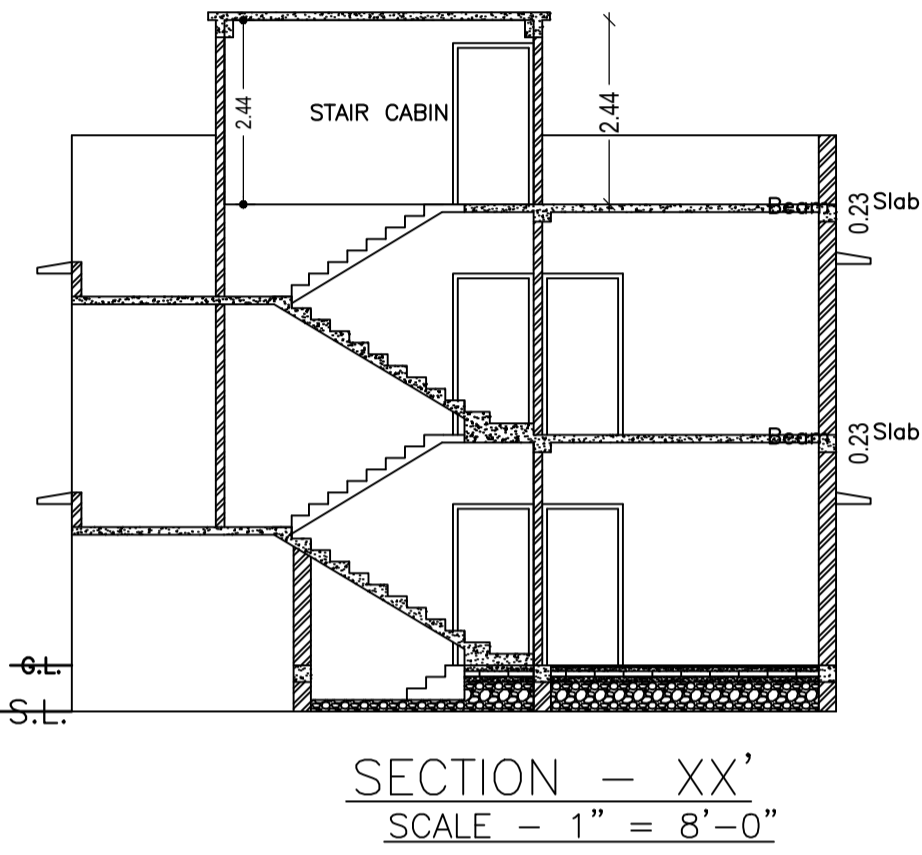
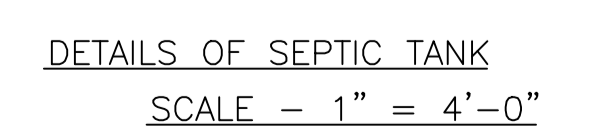
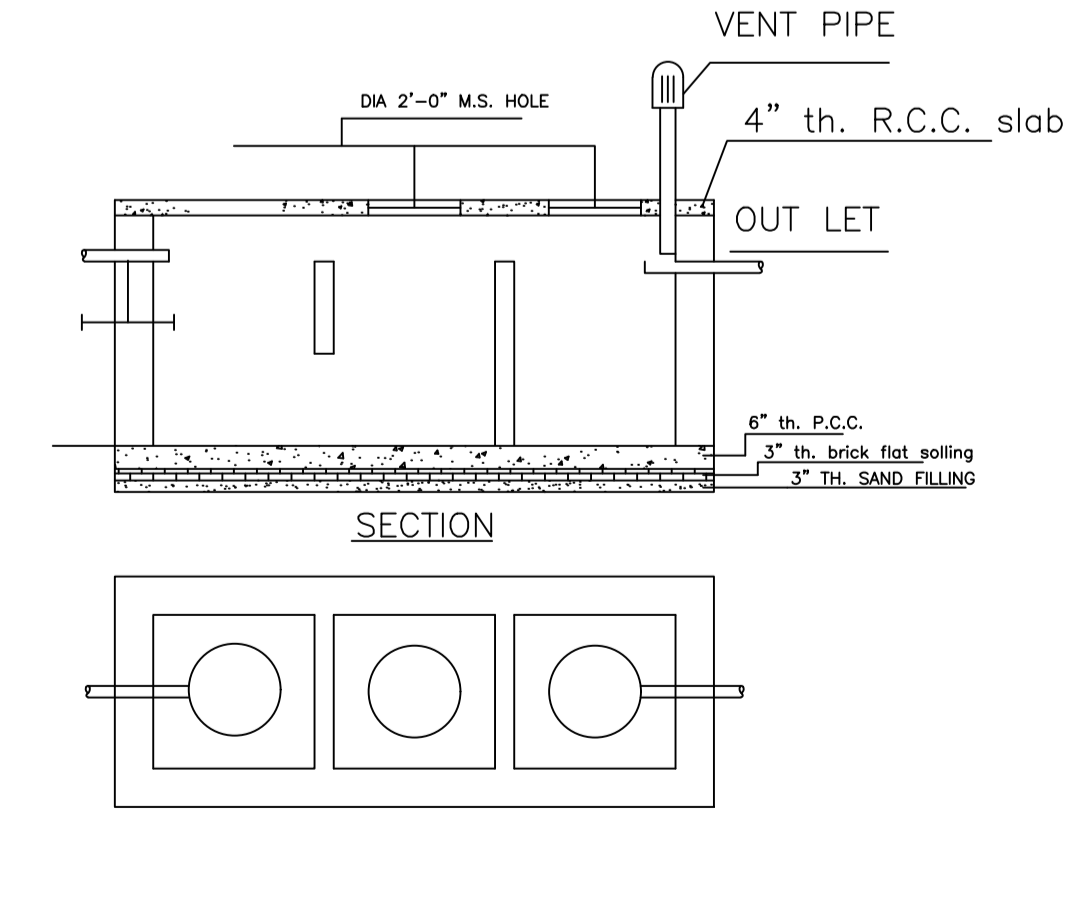
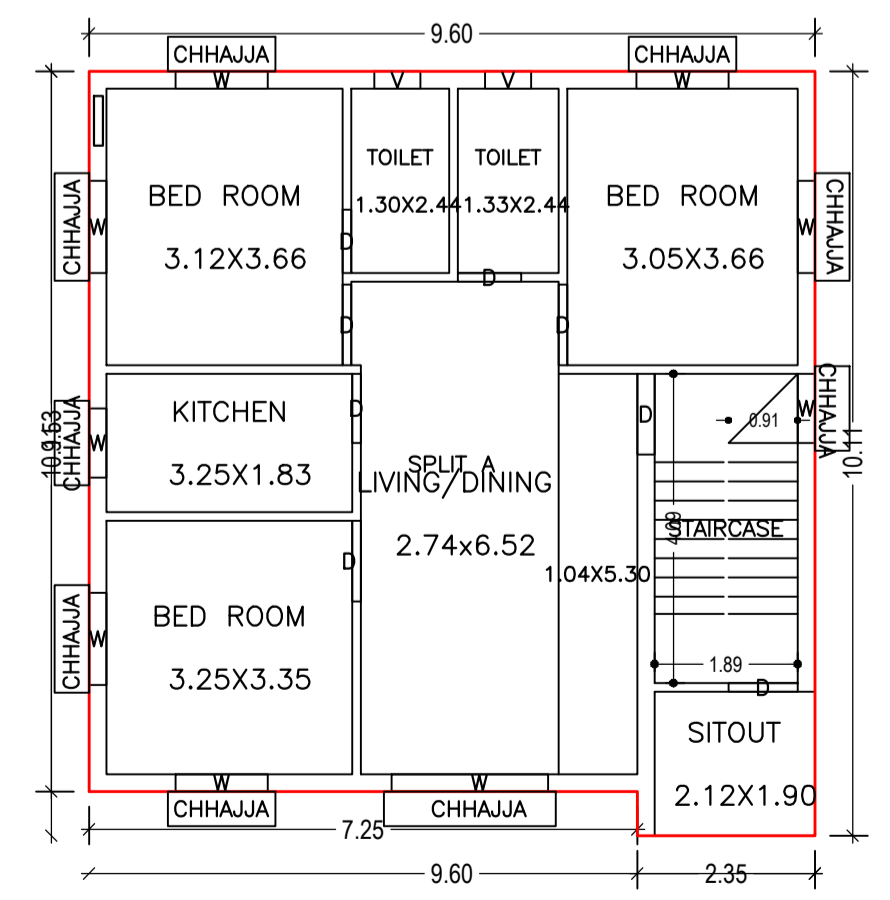
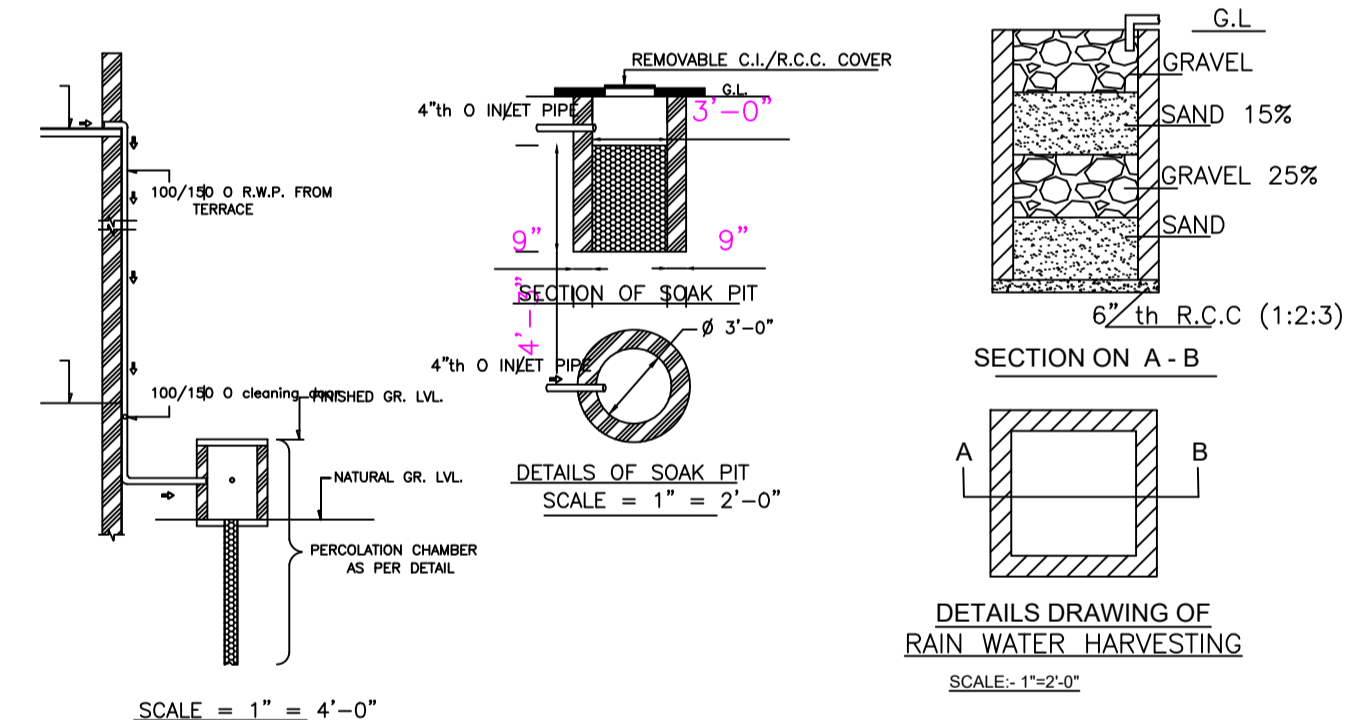
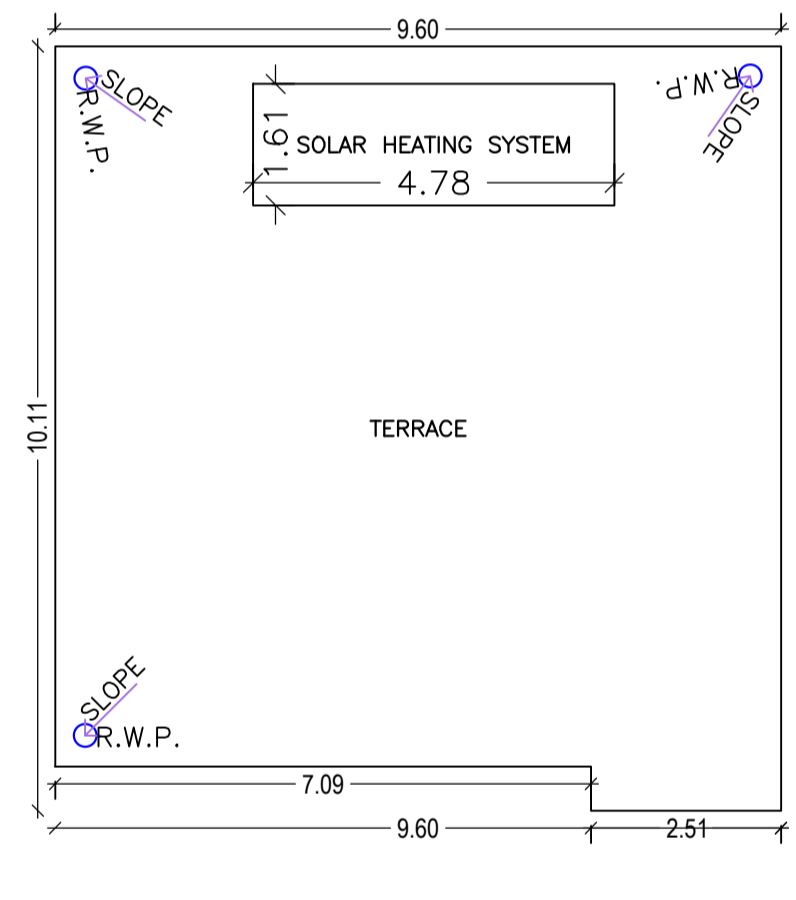
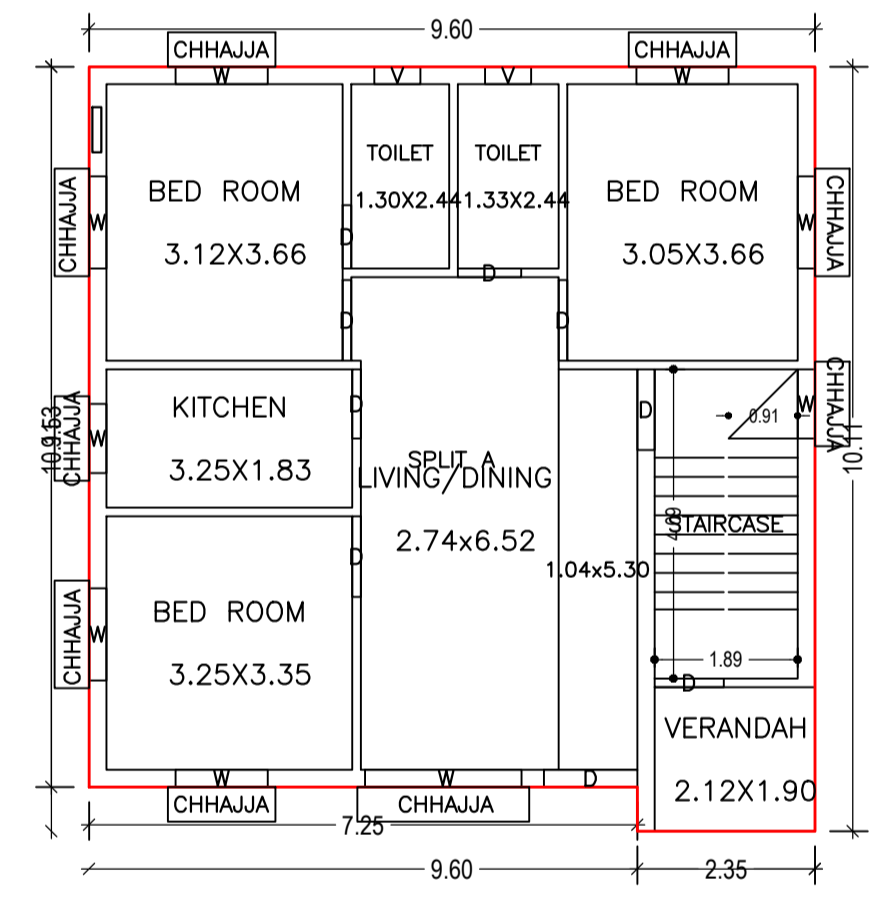

UnitBUA Table for Building :A (NISHAT BEGUM)

FLOOR	Name	UnitBUA Type	UnitBUA Area	Carpet Area	No. of Rooms	No. of Tenement
GROUND FLOOR PLAN	SPLIT A	FLAT	185.65	185.50	8	1
FIRST FLOOR PLAN	SPLIT A	FLAT	0.00	0.00	8	0
Total:	-	-	185.65	185.50	16	1

SCHEDULE OF DOOR:

BUILDING NAME	NAME	LENGTH	HEIGHT	NOS
A (NISHAT BEGUM)	D	0.84	2.10	04
A (NISHAT BEGUM)	D	0.91	2.10	04
A (NISHAT BEGUM)	D	1.07	2.10	08
A (NISHAT BEGUM)	D	1.23	2.10	01

SCHEDULE OF WINDOW/VENTILATION:

BUILDING NAME	NAME	LENGTH	HEIGHT	NOS
A (NISHAT BEGUM)	V	0.61	1.20	04
A (NISHAT BEGUM)	W	0.91	1.20	04
A (NISHAT BEGUM)	W	1.22	1.20	12
A (NISHAT BEGUM)	W	2.07	1.20	02

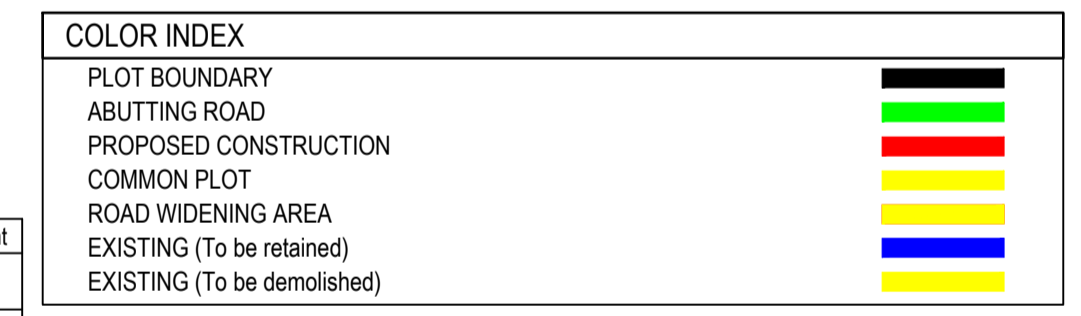
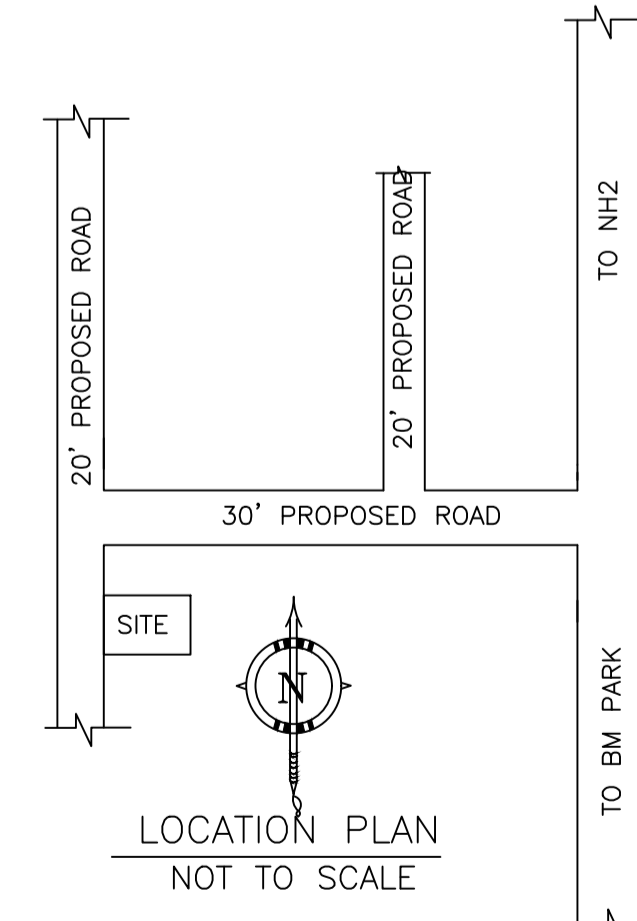

Buildingwise Floor FAR Details

Floor Name	Building Name A (NISHAT BEGUM)		Total	
	Proposed Built Up Area (Sq.mt.)	Proposed FAR Area (Sq.mt.)	Total Proposed Built Up Area (Sq.mt.)	Total FAR Area (Sq.mt.)
Ground Floor	92.82	92.82	92.82	92.82
First Floor	92.82	92.82	92.82	92.82
Terrace Floor	0.00	0.00	0.00	0.00
Total :	185.64	185.64	185.64	185.64

Building USE/SUBUSE Details

Building Name	Building Use	Building SubUse	Building Structure
A (NISHAT BEGUM)	Residential	Bungalow/ Dwelling / Non Apartment	Non-Highrise

FAR & Tenement Details (Table 4c-1)

Building	No. of Same Bldg	Total Built Up Area (Sq.mt.)	Proposed FAR Area (Sq.mt.) Resi.	Total FAR Area (Sq.mt.)	Total Consumed Additional FAR Area (Sq.mt.)	Trmnt (No.)
A (NISHAT BEGUM)	1	185.64	185.64	185.64	185.64	01
Grand Total :	1	185.64	185.64	185.64	185.64	01

LTP NAME AND SIGNATURE STRUCTURAL ENG'S NAME AND SIGNATURE BUILDER NAME AND SIGNATURE DIGITAL SIGNATURE

RAM PRATAP SINGH MADA/ARC/0024/2019			
--	--	--	--