

Project Title : ZEBIA PRAVIN

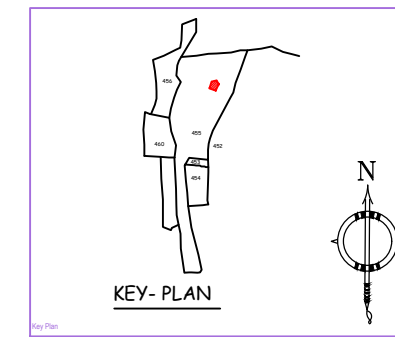
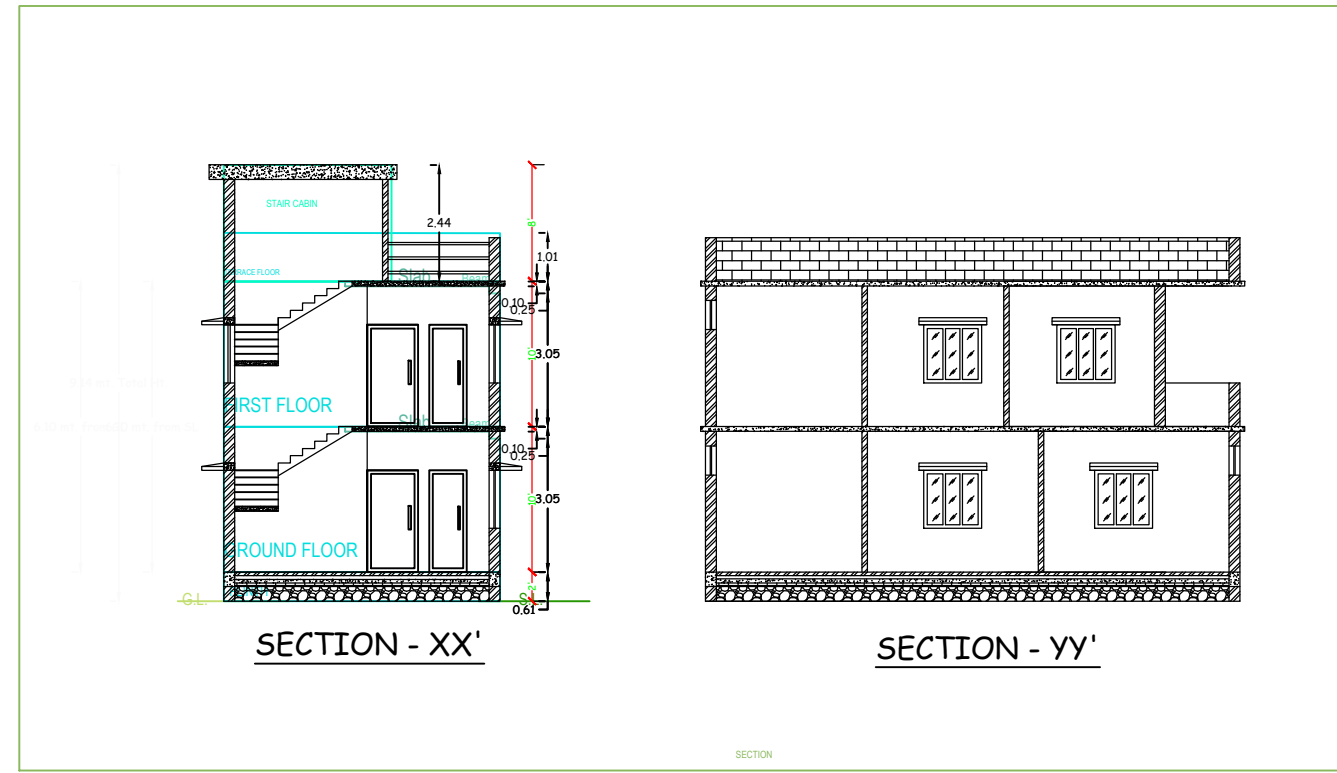
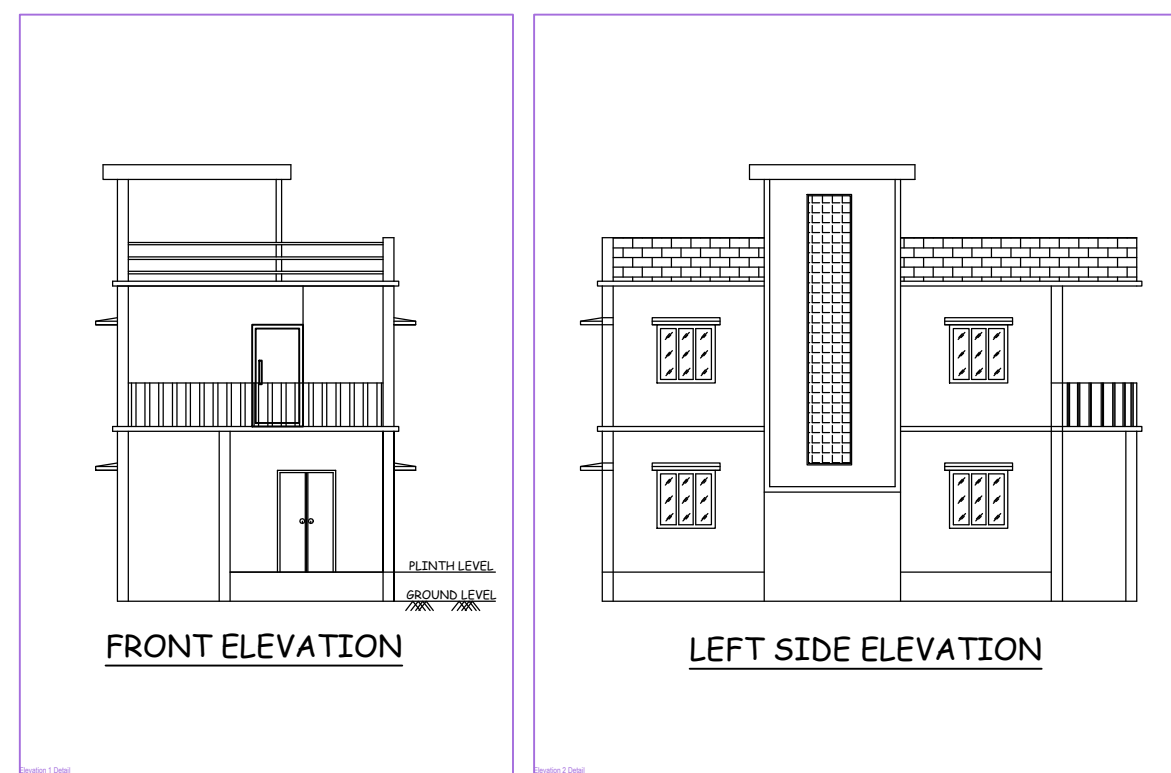

TITLE OF DRAWING
 PROPOSED PLAN FOR ZEBIA PRAVIN W/O AFROJ AHMAD, AT PRESENT RESIDING AT, QTR NO-166 D-BLOCK SECTOR-9/B, NEAR HANUMAN MANDIR BHULI, PO. BHULI, PS- BANK MORE DIST. DHANBAD (JHARKHAND)
 FOR RESIDENTIAL BUILDING AT, NEW KHATA NO- 52, OLD KHATA NO- 36, NEW PLOT NO- 455_OLD PLOT NO- 314, AREA-2.86 DECIMAL SITUATED AT MOUZA NO-168, MAUZA -GAYDAHRA (GOVINDPUR) DISTRICT- DHANBAD (J H A R K H A N D)

BRIEF SPECIFICATION
 FOUNDATION----- CEMENT CONCRETE (1:3:6)
 FOOTINGS----- R.C.C. (1:1½:3)
 BRICK WORK IN FOUNDATION & SUPERSTRUCTURE
 FIRST CLASS BRICK WORK IN CEMENT MORTAR (1:2:4)
 D.P.C.-----1" D.P.C. IN CEMENT CONCRETE (1:2:4)
 COLUMNS----- R.C.C. (1:1½:3)
 BEAM----- R.C.C. (1:1½:3)
 FLOOR-----1" I.P.S. OVER 3" P.C.C.
 ROOF-----4" THK. R.C.C. LINTEL (1:1½:3)
 LINTEL-----6" THK. R.C.C. LINTEL (1:1½:3)
 STAIRS----- RISE- 6", TREAD- 10"
 DOORS----- D-3'3"X7'0", D1-3'0"X7'0", D2-2'6"X7'0"
 WINDOWS-----W-5'0"X4'0", W1-4'0"X4'0", W2-2'6"X4'0"
 VENTS-----V-2'0"X2'0"

SCHEDULE

D - 3'-6" X 7'-0"	W - 4'-0" x 4'-0"
D1 - 3'-0" X 7'-0"	W1 - 3'-0" x 4'-0"
D2 - 2'-6" X 7'-0"	V - 2'-0" x 2'-0"

DETAILS OF AREA

LAND AREA	: 1250 Sft.
GROUND FLOOR AREA	: 698.25 Sft.
FIRST FLOOR AREA	: 698.25 Sft.
COVERED AREA	: 1396.50 Sft.
% OF PLINTH AREA	: 55.86%
F.A.R	: 1.11

SIGN OF OWNER
 SIGN OF ARCHITECT
 ARCH. BAHU PRATAP SINGH

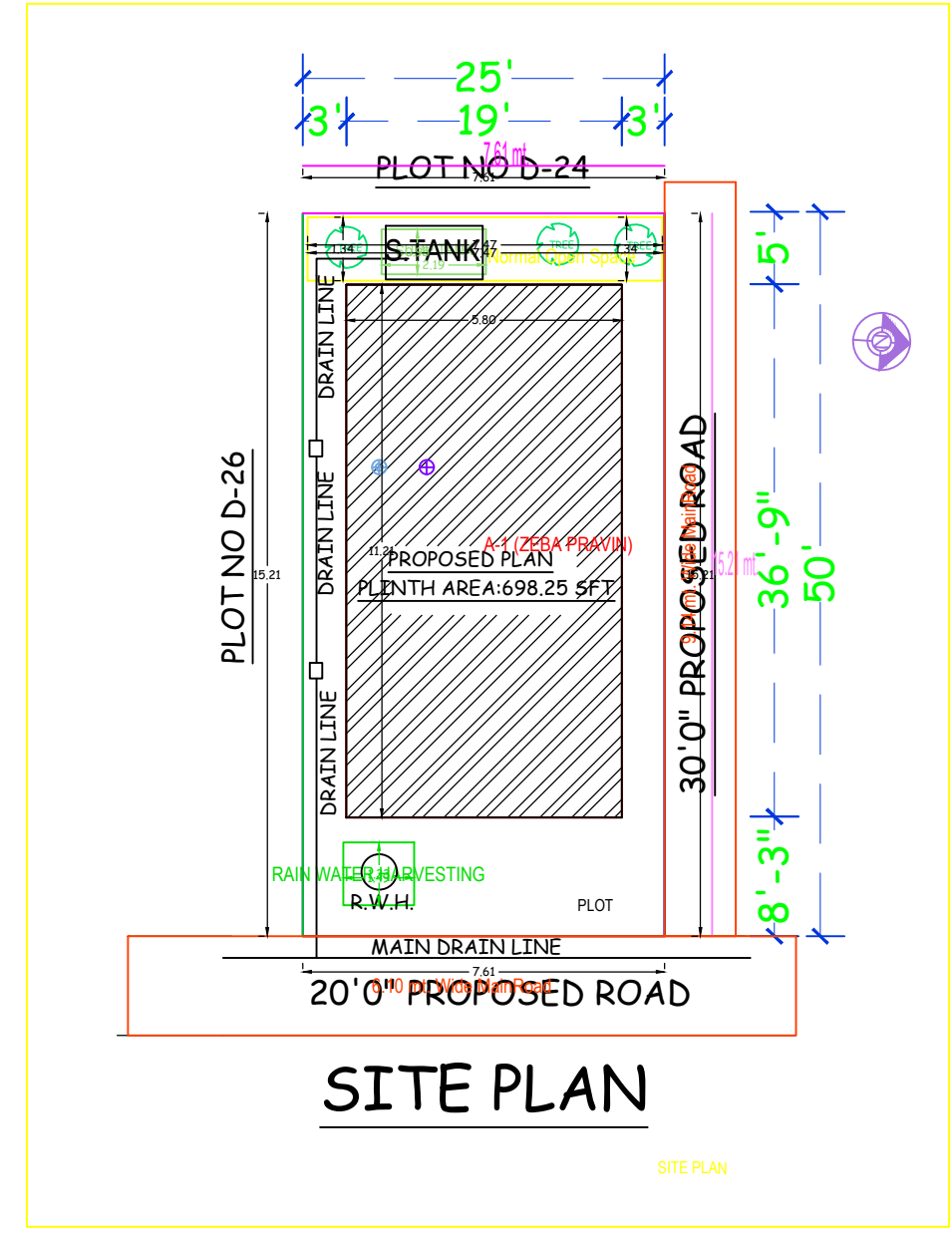
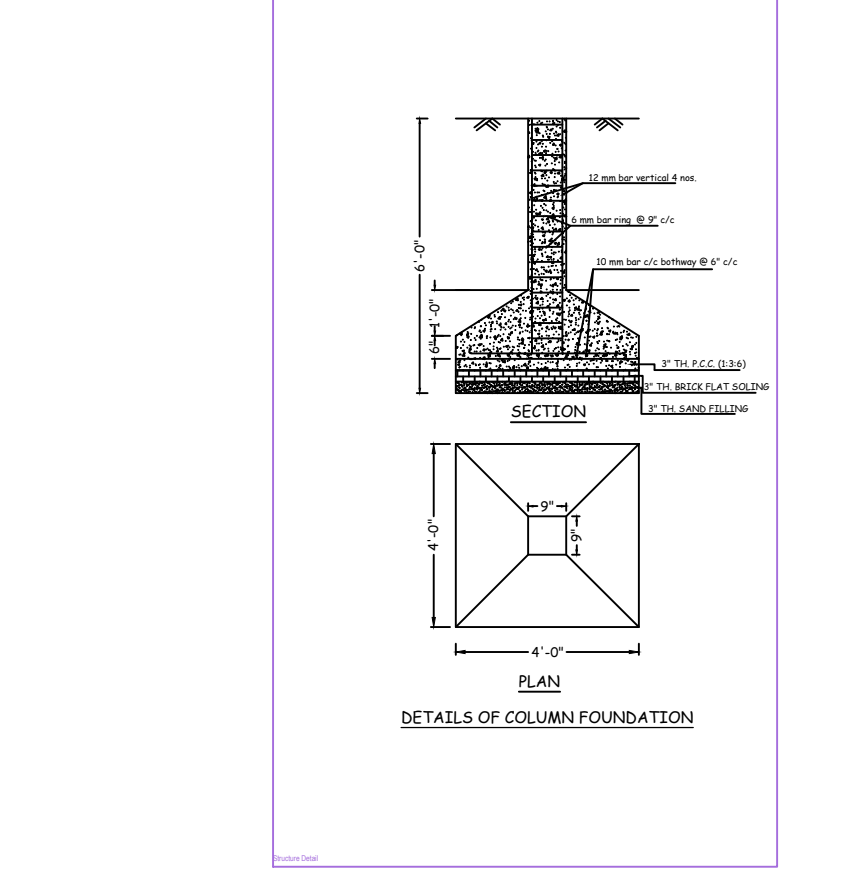
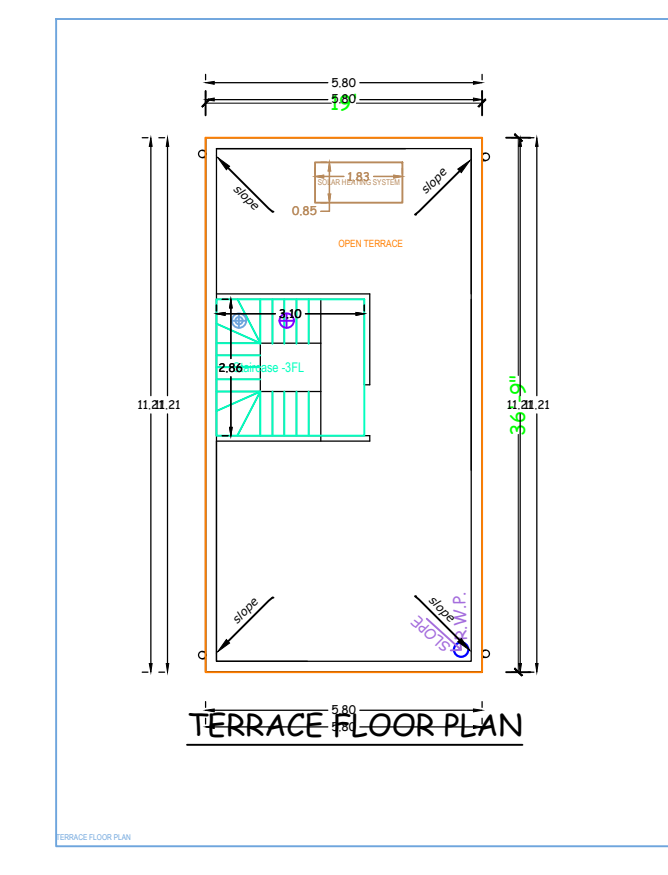
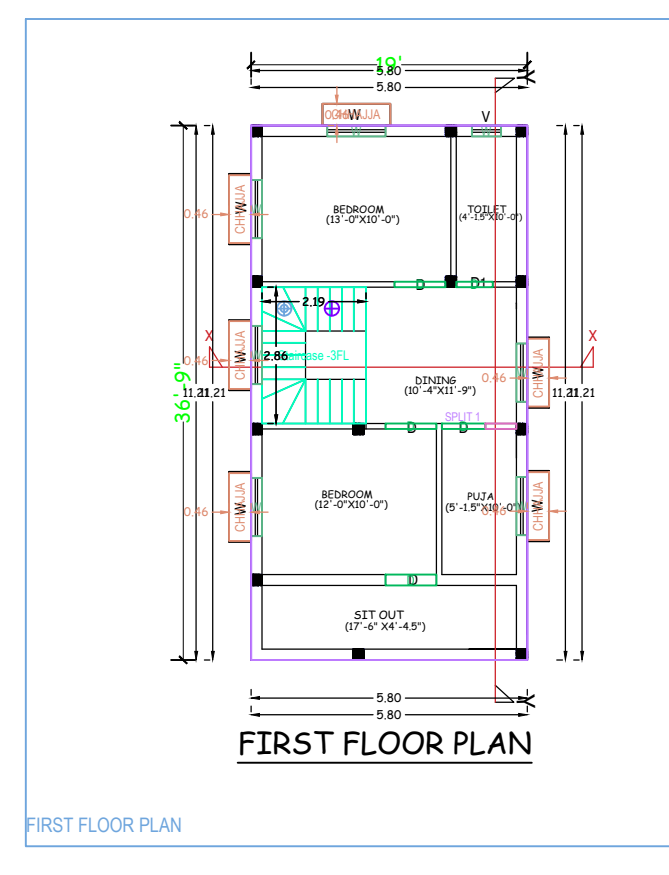
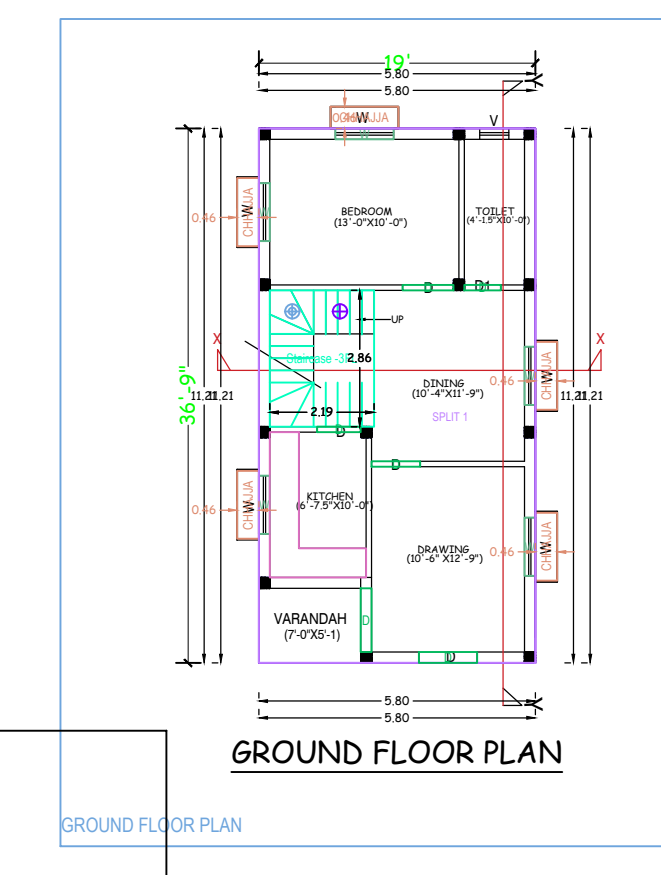
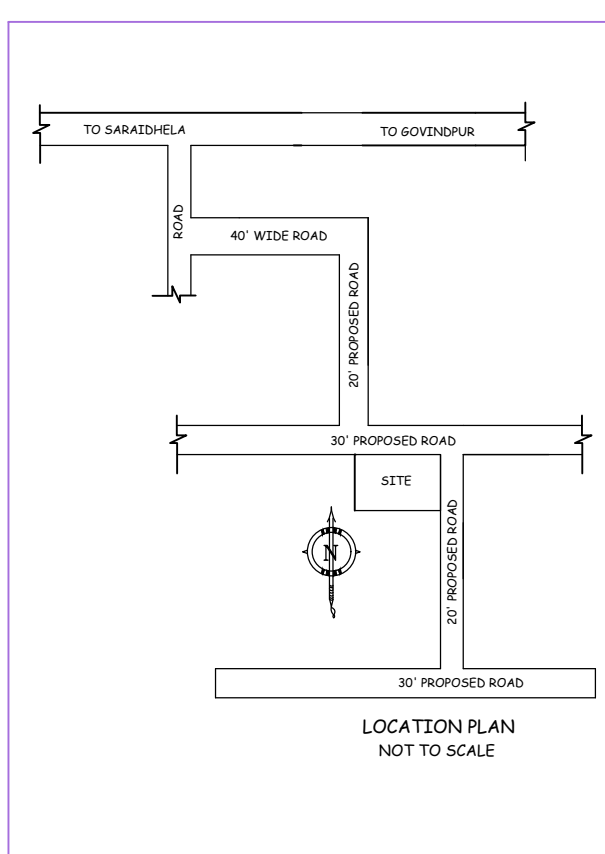
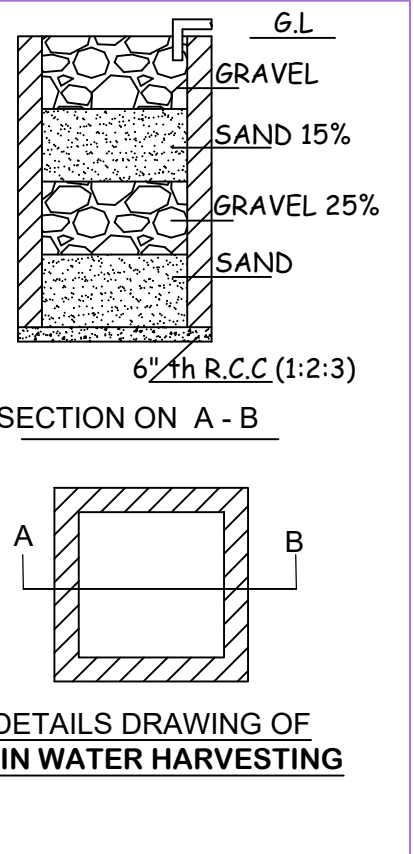
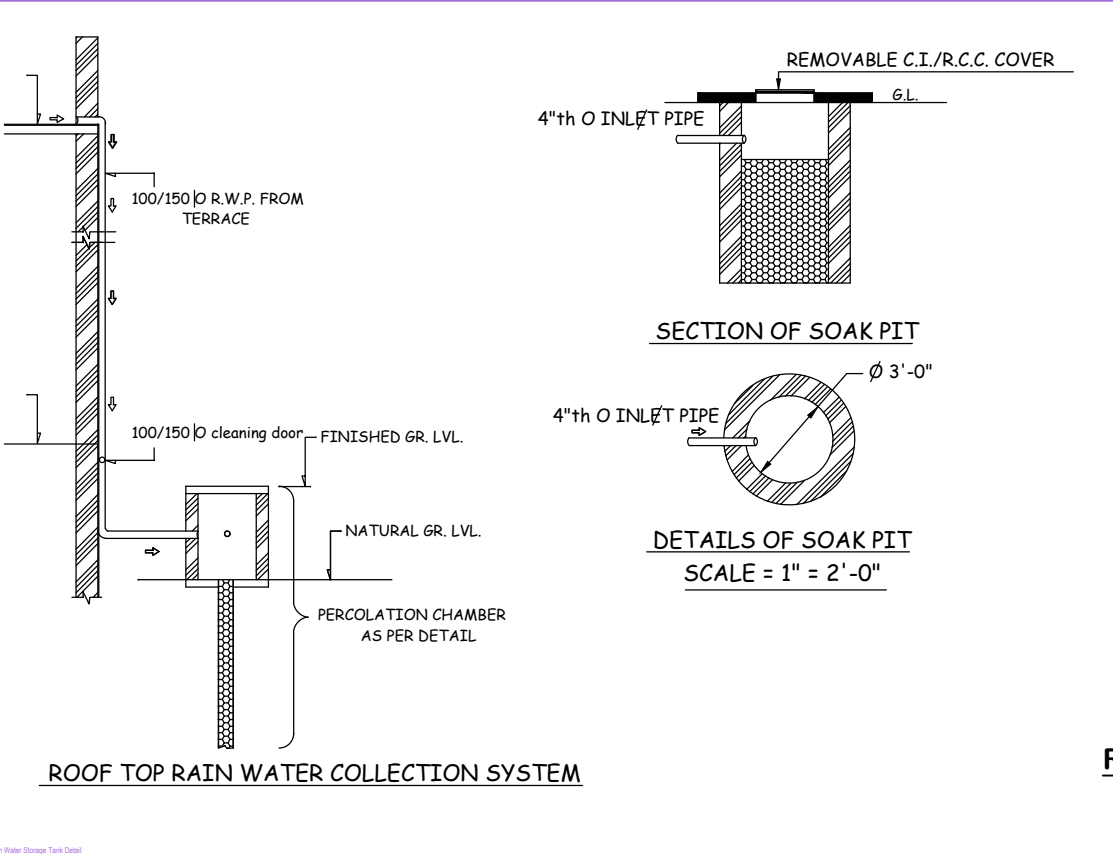
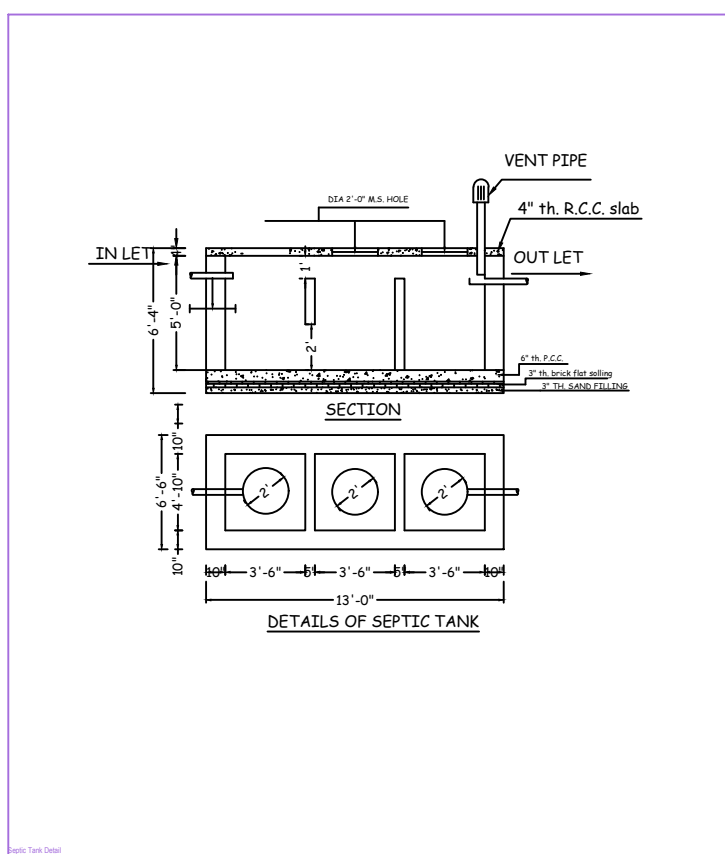

AREA STATEMENT MINERAL AREA DEVELOPMENT AUTHORITY	VERSION NO. 1.0.36
PROJECT DETAIL	VERSION DATE: 16/10/2020
Plot No. -	Plot Use - Residential
Region - JHARKHAND (URBAN LOCAL BODIES)	Plot Sub-Use - Bungalow/ Dwelling / Non Apartment
Location (WARD/BLK)	Land Use Zone - RA
Application Type - General Proposal	Abutting Road Width -
Project Type - Building Permission	Plot No. -
Nature of Development - New	Revenue Survey No./Survey No. -
Location - Old Area	Thana No. -
Sub Location - NA	Holding No. -
Village/Nezha Name -	Phase No. -
Ward No. -	North -
Road Name -	South -
	East -
	West -

COLOR INDEX

PLINTH BOUNDARY	Black
ABUTTING ROAD	Red
PROPOSED WORK COVERAGE AREA	Green
EXISTING (To be retained)	Blue
EXISTING (To be demolished)	Yellow

Color Index
 MARGIN DETAIL:

Building/ W/S	Road Name	Front Margin	Rear Margin	Side Margin	Slid Margin
A (ZEBIA PRAVIN)	6.10 mt. Wide PROPOSED	2.50	1.50	0.90	0.91

FAR & Tenement Details (Table 4c-1)

Building	No. of Served Bldg.	Total Bldg. Area (Sq.Mt.)	Proposed FAR Area (Sq.Mt.)	Total FAR Area (Sq.Mt.)	Tenmt. (No.)
A (ZEBIA PRAVIN)	1	129.90	129.90	129.90	01
Grand Total	1	129.90	129.90	129.90	01

Building - A (ZEBIA PRAVIN)

Floor Name	Total Built-Up Area (Sq.Mt.)	Proposed FAR Area (Sq.Mt.)	Proposed FAR Area (Sq.Mt.)	Tenmt. (No.)
Ground Floor	64.95	64.95	64.95	01
First Floor	64.95	64.95	64.95	01
Terrace Floor	0.00	0.00	0.00	00
Total	129.90	129.90	129.90	01

SCHEDULE OF JOINERY:

BUILDING NAME	NAME	LENGTH	HEIGHT	NO.
A (ZEBIA PRAVIN)	D	0.76	2.10	02
A (ZEBIA PRAVIN)	D	0.92	2.10	02
A (ZEBIA PRAVIN)	D	1.02	2.10	01
A (ZEBIA PRAVIN)	D	1.07	2.10	04
A (ZEBIA PRAVIN)	D	1.22	2.10	01
A (ZEBIA PRAVIN)	D	1.33	2.10	01
Total	-	-	-	11

SCHEDULE OF JOINERY:

BUILDING NAME	NAME	LENGTH	HEIGHT	NO.
A (ZEBIA PRAVIN)	W	0.61	1.30	01
A (ZEBIA PRAVIN)	W	1.23	1.30	11
Total	-	-	-	12

Unit/BUA Table for Building - A (ZEBIA PRAVIN)

FLOOR	Name	Unit/BUA Type	Unit/BUA Area	Carpet Area	No. of Rooms	No. of Tenement
GROUND FLOOR PLAN	SPLIT 1	FLAT	129.91	127.11	6	1
Total	-	-	129.91	127.11	12	1