

SITE PLAN
SCALE :- 1IN=200
SITE PLAN

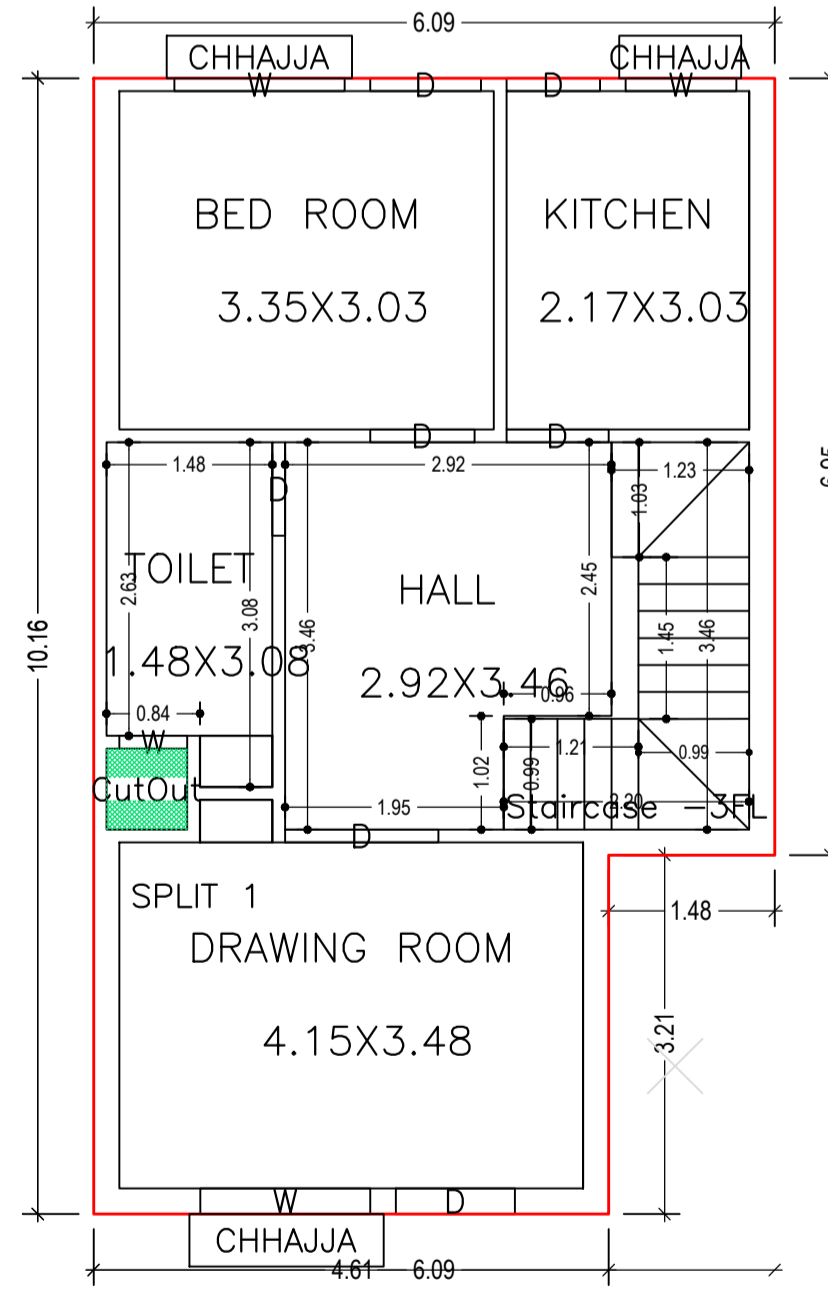

GROUND FLOOR PLAN (Proposed)
SCALE 1:100

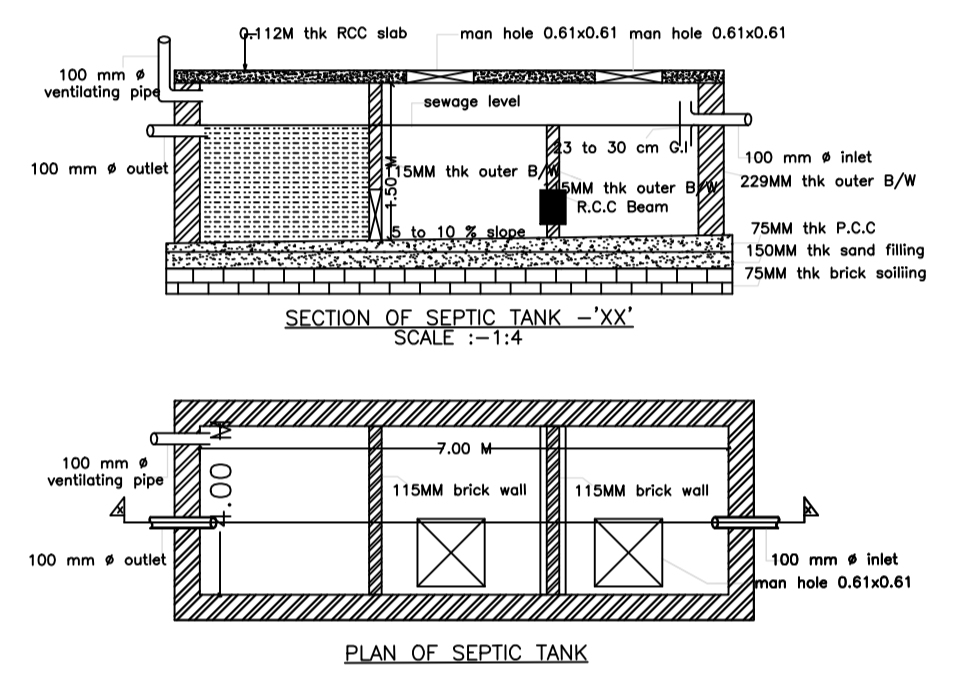
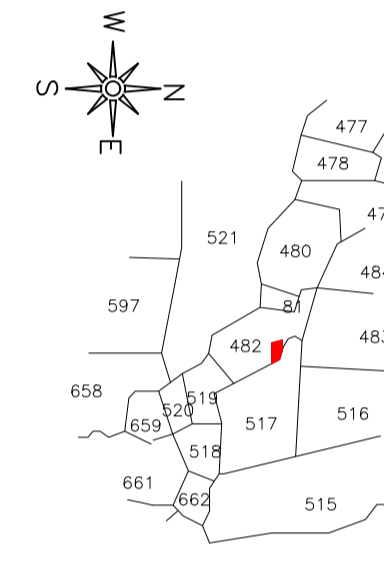
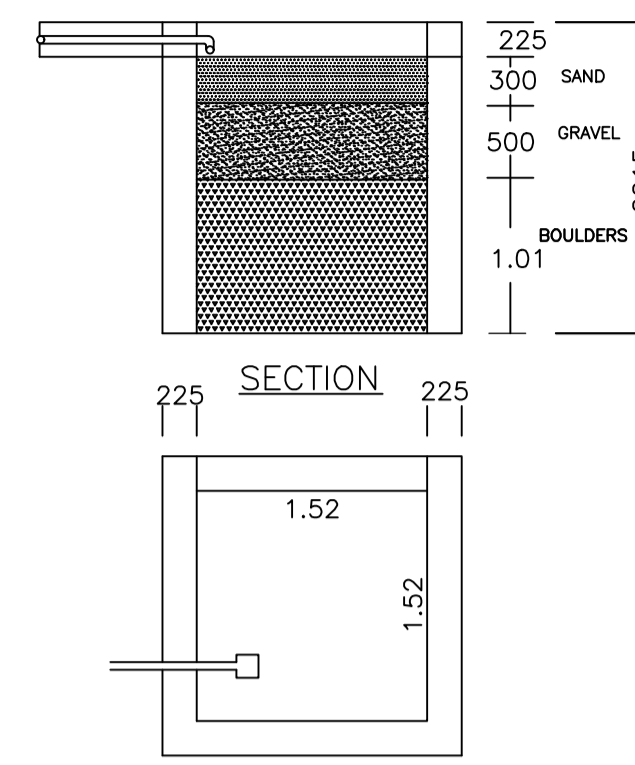
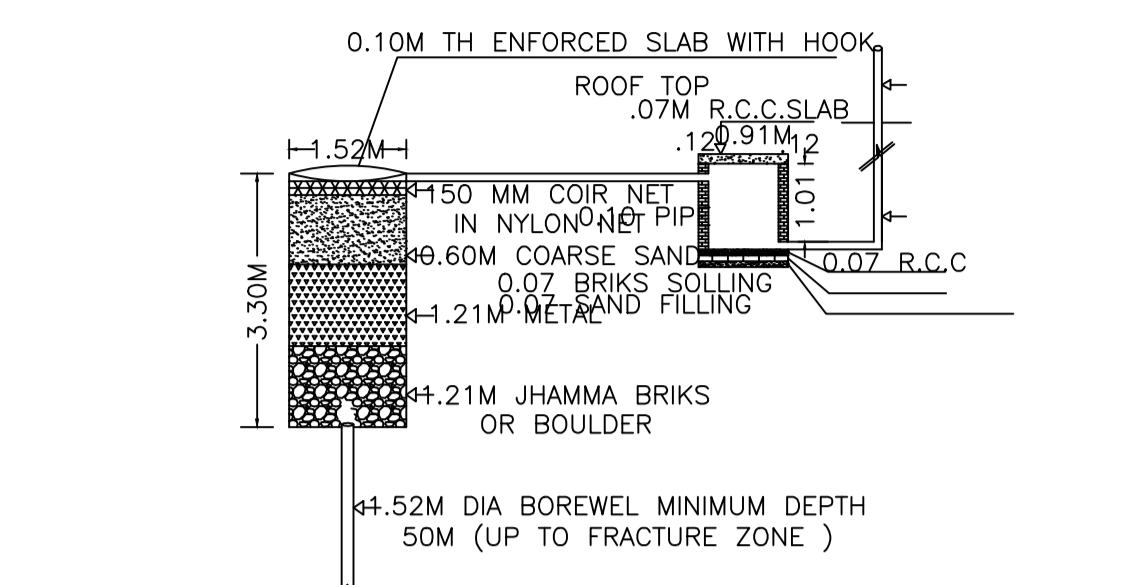
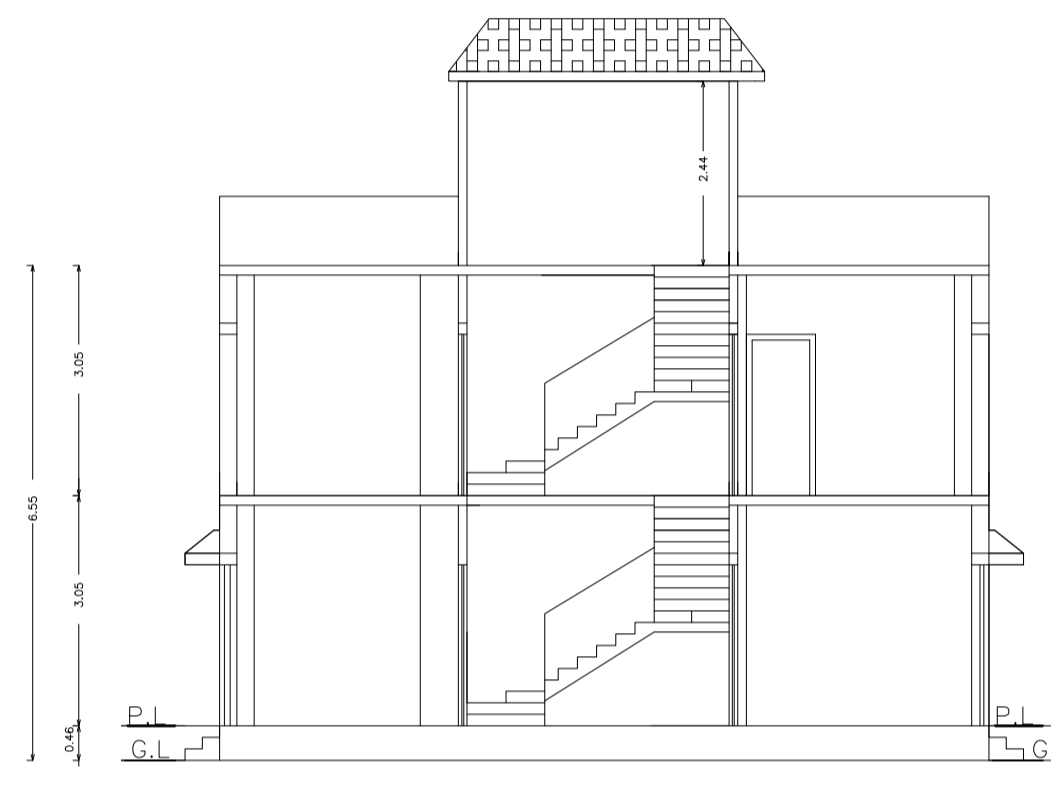
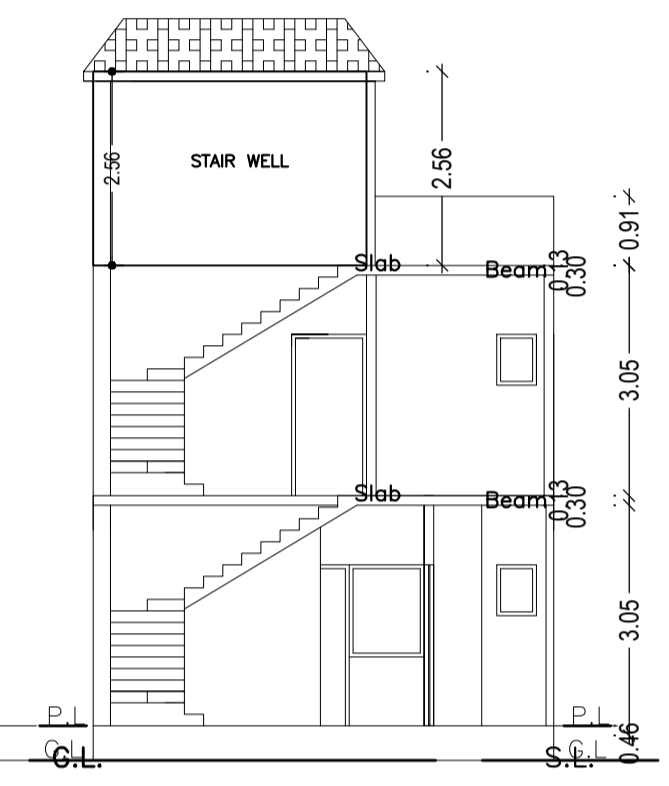
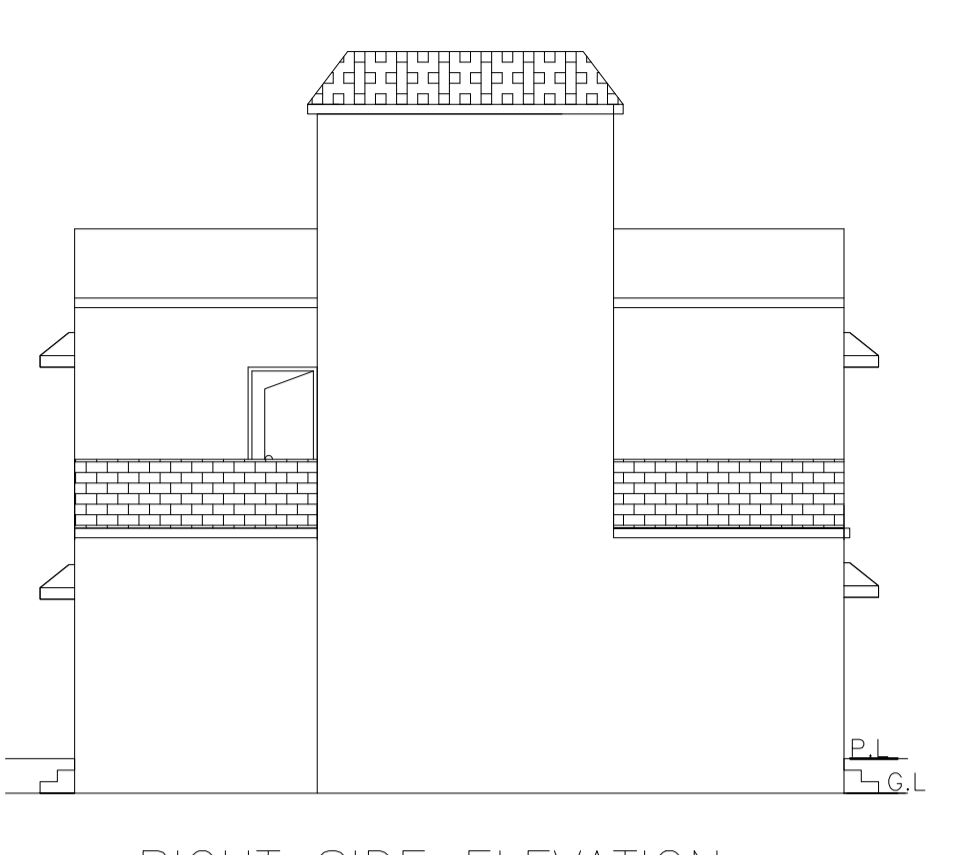
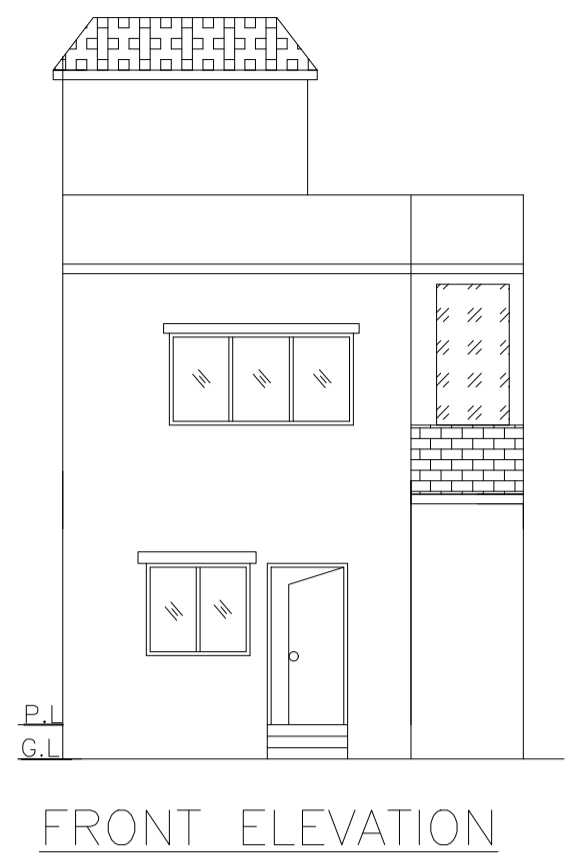
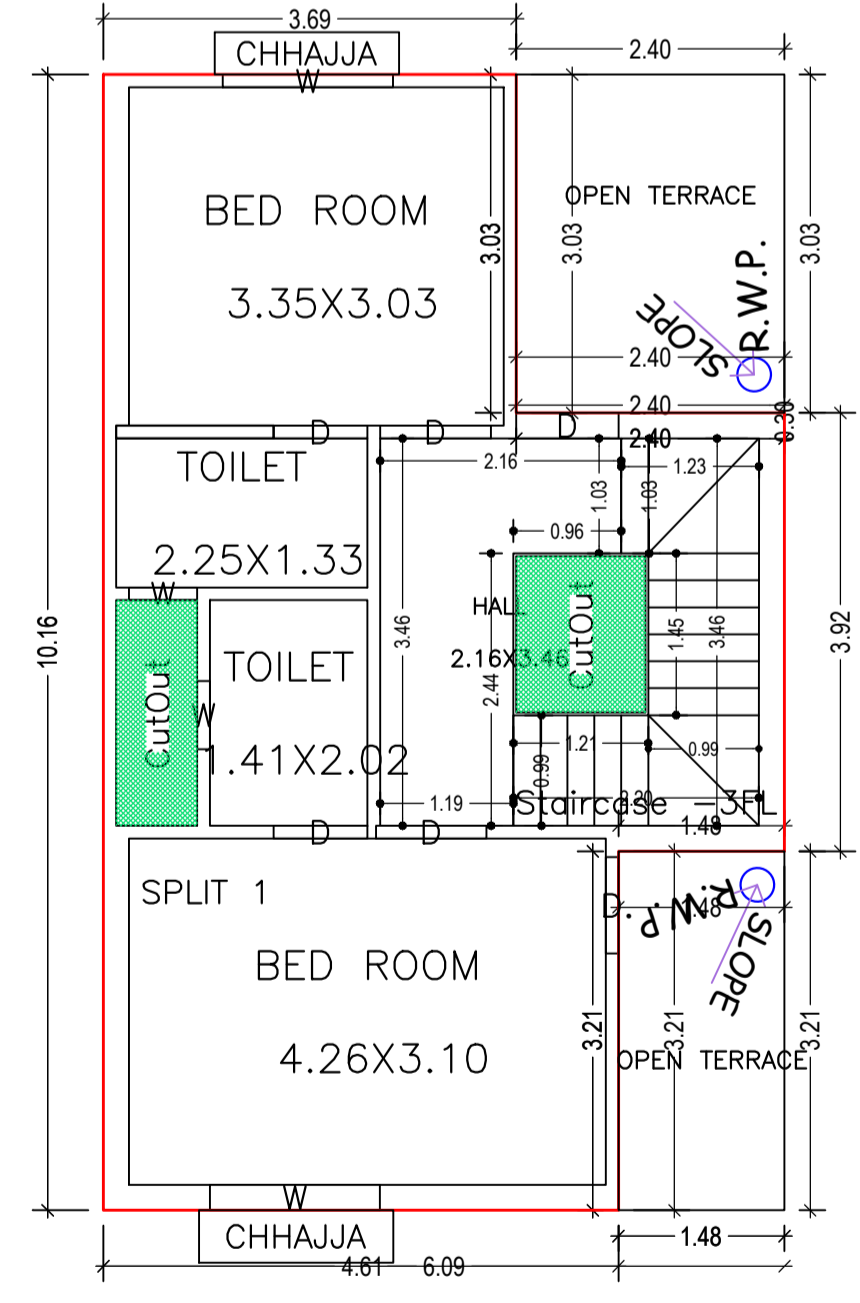

FIRST FLOOR PLAN (Proposed)
SCALE 1:100

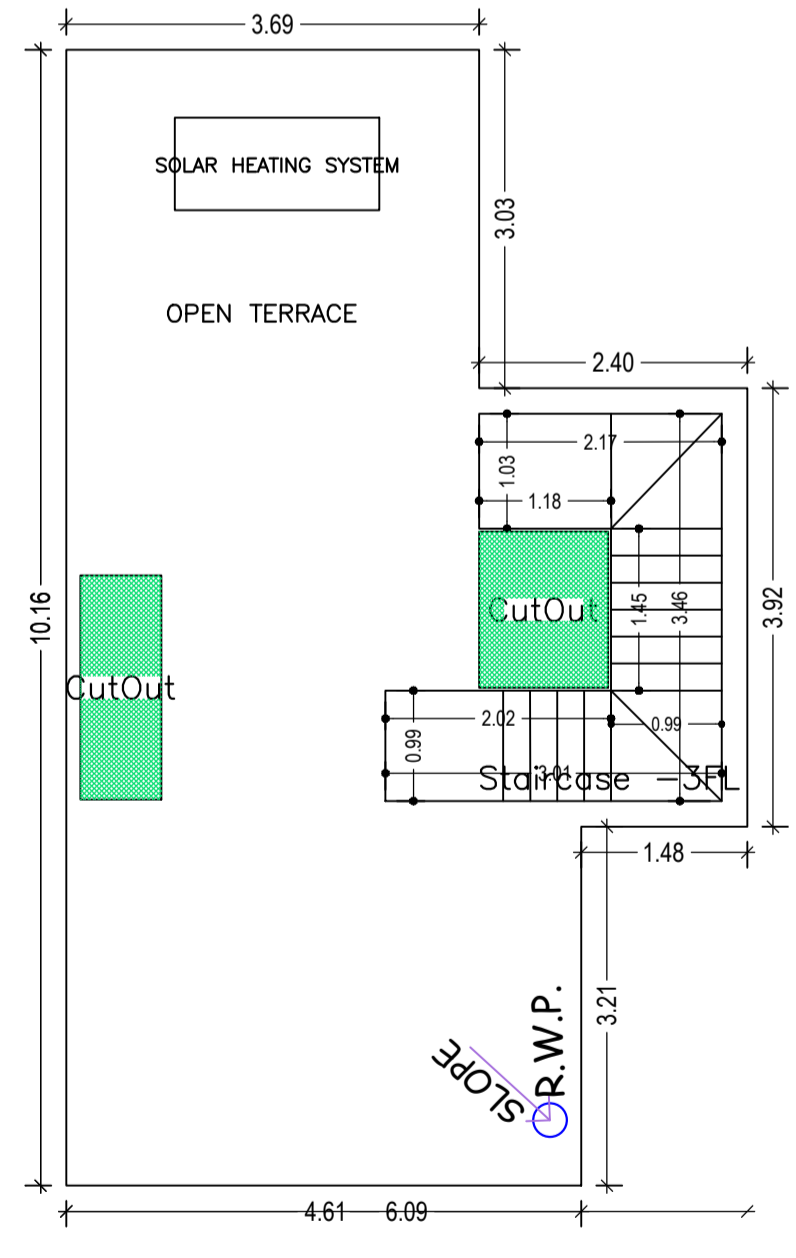

TERRACE FLOOR PLAN (SCALE 1:100)

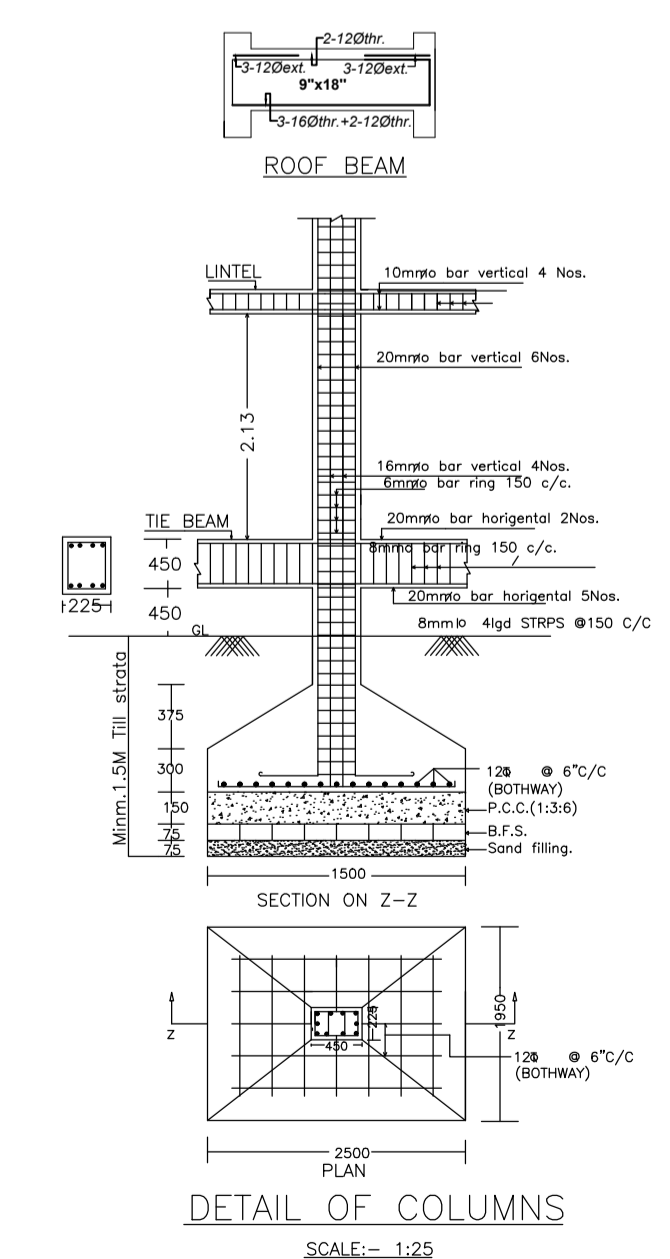
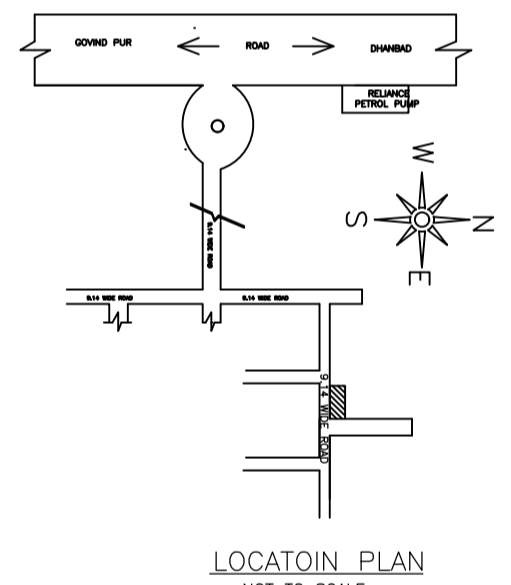

Building :RESI (PREM)

| Floor Name | Gross Builtup Area | Deductions From Gross BUA/Area in Sq.mt.) | Total Built Up Area (Sq.mt.) | Proposed FAR Area (Sq.mt.) | Total FAR Area (Sq.mt.) | Total Consumed Additional FAR Area (Sq.mt.) | Trmt (No.) |
|---------------|--------------------|---|------------------------------|----------------------------|-------------------------|---|------------|
| Ground Floor | 57.10 | 0.52 | 56.58 | 56.58 | 56.58 | 56.58 | 01 |
| First Floor | 49.84 | 3.07 | 46.77 | 46.77 | 46.77 | 46.77 | 00 |
| Terrace Floor | 0.00 | 0.00 | 0.00 | 0.00 | 0.00 | 0.00 | 00 |
| Total : | 106.94 | 3.59 | 103.35 | 103.35 | 103.35 | 103.35 | 01 |

SCHEDULE OF DOOR:

| BUILDING NAME | NAME | LENGTH | HEIGHT | NOS |
|---------------|------|--------|--------|-----|
| RESI (PREM) | D | 0.84 | 2.10 | 04 |
| RESI (PREM) | D | 0.86 | 2.10 | 01 |
| RESI (PREM) | D | 0.91 | 2.10 | 02 |
| RESI (PREM) | D | 0.93 | 2.10 | 01 |
| RESI (PREM) | D | 0.99 | 2.10 | 03 |
| RESI (PREM) | D | 1.07 | 2.10 | 01 |
| RESI (PREM) | D | 1.37 | 2.10 | 01 |

SCHEDULE OF WINDOW/VENTILATION:

| BUILDING NAME | NAME | LENGTH | HEIGHT | NOS |
|---------------|------|--------|--------|-----|
| RESI (PREM) | W | 0.61 | 1.20 | 03 |
| RESI (PREM) | W | 0.99 | 1.20 | 01 |
| RESI (PREM) | W | 1.52 | 1.20 | 04 |

UnitBUA Table for Building :RESI (PREM)

| FLOOR | Name | UnitBUA Type | UnitBUA Area | Carpet Area | No. of Rooms | No. of Tenement |
|-------------------|---------|--------------|--------------|-------------|--------------|-----------------|
| GROUND FLOOR PLAN | SPLIT 1 | FLAT | 103.35 | 102.64 | 5 | 1 |
| FIRST FLOOR PLAN | SPLIT 1 | FLAT | 0.00 | 0.00 | 5 | 0 |
| Total: | - | - | 103.35 | 102.64 | 10 | 1 |

Proposal Basic Information

| | |
|-------------------|------------------------------------|
| Proposal File No. | MADA/BP/0265/2023 |
| Owner Name | SRI PREM KUMAR |
| Khata No | 27 (OLD), 198 (NEW) |
| Plot No | 585 (OLD), 482 (NEW) |
| Village Name | Amaghata |
| Use | Residential |
| SubUse | Bungalow/ Dwelling / Non Apartment |

| | | |
|---|--|---|
| AREA STATEMENT MINERAL AREA DEVELOPMENT AUTHORITY | VERSION NO.: 1.0.66 | VERSION DATE: 16/10/2020 |
| PROJECT DETAIL: | Region: JHARKHAND URBAN LOCAL BODIES | Plot Use: Residential |
| Authority: MINERAL AREA DEVELOPMENT AUTHORITY | Inward No: MADA/BP/0265/2023 | Plot SubUse: Bungalow/ Dwelling / Non Apartment |
| Application Type: General Proposal | Project Type: Building Permission | PlotNearby/ReligiousStructure: NA |
| Nature of Development: New | Location of Development Area: Old Area | Plot/SubPlot No: 585 (OLD), 482 (NEW) |
| Location of Development Area: Old Area | Area | North: Plot No. - LOT NO-93 |
| Area | Area | South: Road Width - 9.14 |
| Area | Area | East: Road Width - 9.14 |
| Area | Area | West: Plot No. - LOT NO-91 |
| AREA DETAILS: | AREA OF PLOT (Minimum) | (A) |
| AREA DETAILS: | NET AREA OF PLOT(Gross Plot Area - Deduction from Gross Plot area) | (A-Deductions) |
| AREA DETAILS: | Deduction for Balance Plot Area(from Gross Plot Area) | |
| AREA DETAILS: | Common Plot | 12 |
| AREA DETAILS: | Total | 12 |
| AREA DETAILS: | BALANCE AREA OF PLOT(Net Plot Area - Recreational/Amenity space) | (A-Deductions) |
| AREA DETAILS: | PLOT AREA FOR COVERAGE(Net Plot Area) | (A-Deductions) |
| AREA DETAILS: | Plot Area for FAR (Net Plot Area + Road Widening Area) | (A-Deductions) |
| AREA DETAILS: | COVERAGE CHECK | |
| AREA DETAILS: | Permissible Coverage area (70.00 %) | 95 |
| AREA DETAILS: | Proposed Coverage Area (41.27 %) | 56 |
| AREA DETAILS: | Total Prop. Coverage Area (41.27 %) | 56 |
| AREA DETAILS: | Balance coverage area (28.73 %) | 39 |
| AREA DETAILS: | FAR CHECK | |
| AREA DETAILS: | Perm. FAR Area (2.500) | 342 |
| AREA DETAILS: | Total Perm. FAR area | 342 |
| AREA DETAILS: | Residential FAR | 103 |
| AREA DETAILS: | Proposed FAR Area | 103 |
| AREA DETAILS: | Total Proposed FAR Area | 103 |
| AREA DETAILS: | Consumed FAR (Factor) | 0 |
| AREA DETAILS: | Balance FAR Area | 239 |
| AREA DETAILS: | BUILT UP AREA CHECK | |
| AREA DETAILS: | Total Proposed BuiltUp Area | 103 |
| AREA DETAILS: | ARCHITECT (Regd) | ANIL KUMAR CHAUDHARY |
| AREA DETAILS: | ENGINEER (Regd) | |
| AREA DETAILS: | SUPERVISOR (Regd) | |
| AREA DETAILS: | OWNER (Regd) | SRI PREM KUMAR |
| AREA DETAILS: | DEVELOPMENT AUTHORITY | LOCAL BODY |

COLOR INDEX

| | |
|-----------------------------|--------|
| PLOT BOUNDARY | Green |
| ABUTTING ROAD | Red |
| PROPOSED CONSTRUCTION | Yellow |
| COMMON PLOT | Blue |
| ROAD WIDENING AREA | Orange |
| EXISTING (To be retained) | Grey |
| EXISTING (To be demolished) | Black |

Buildingwise Floor FAR Details

| Floor Name | Building Name | | Total | |
|---------------|---------------------------------|----------------------------|---------------------------------------|-------------------------|
| | Proposed Built Up Area (Sq.mt.) | Proposed FAR Area (Sq.mt.) | Total Proposed Built Up Area (Sq.mt.) | Total FAR Area (Sq.mt.) |
| Ground Floor | 56.58 | 56.58 | 56.58 | 56.58 |
| First Floor | 46.77 | 46.77 | 46.77 | 46.77 |
| Terrace Floor | 0.00 | 0.00 | 0.00 | 0.00 |
| Total : | 103.35 | 103.35 | 103.35 | 103.35 |

Building USE/SUBUSE Details

| Building Name | Building Use | Building SubUse | Building Structure |
|---------------|--------------|------------------------------------|--------------------|
| RESI (PREM) | Residential | Bungalow/ Dwelling / Non Apartment | Non-Highrise |

FAR & Tenement Details (Table 4c-1)

| Building | No. of Same Bldg | Gross Built Up Area (Sq.mt.) | Deductions From Gross BUA/Area in Sq.mt.) | Total Built Up Area (Sq.mt.) | Proposed FAR Area (Sq.mt.) | Total FAR Area (Sq.mt.) | Total Consumed Additional FAR Area (Sq.mt.) |
|---------------|------------------|------------------------------|---|------------------------------|----------------------------|-------------------------|---|
| RESI (PREM) | 1 | 106.94 | 3.59 | 103.35 | 103.35 | 103.35 | 103.35 |
| Grand Total : | 1 | 106.94 | 3.59 | 103.35 | 103.35 | 103.35 | 103.35 |

| | | | |
|--|-------------------------------------|----------------------------|-------------------|
| LTP NAME AND SIGNATURE ANIL KUMAR CHAUDHARY MADA/ENG/0005/2019 | STRUCTURAL ENG'S NAME AND SIGNATURE | BUILDER NAME AND SIGNATURE | DIGITAL SIGNATURE |
|--|-------------------------------------|----------------------------|-------------------|