

Project Title : 1. SRI SHANKAR DAS AND 2. SMT DEWANTI DEVI

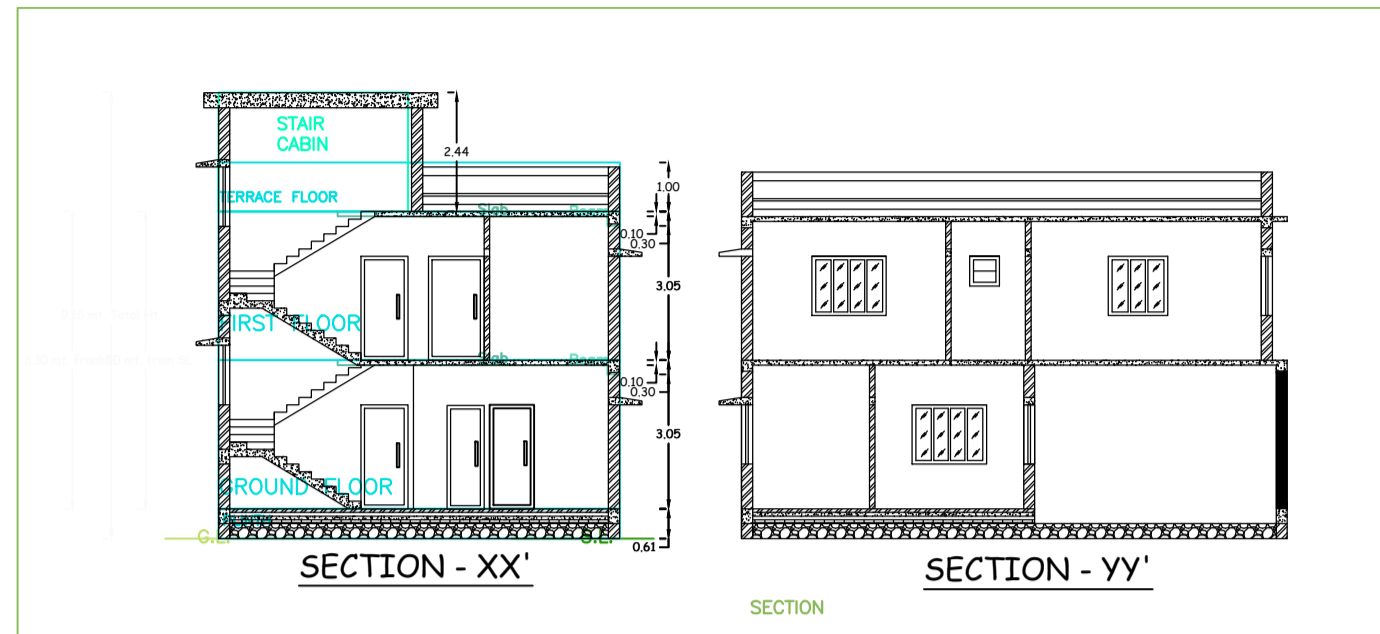

FOR MADA USE

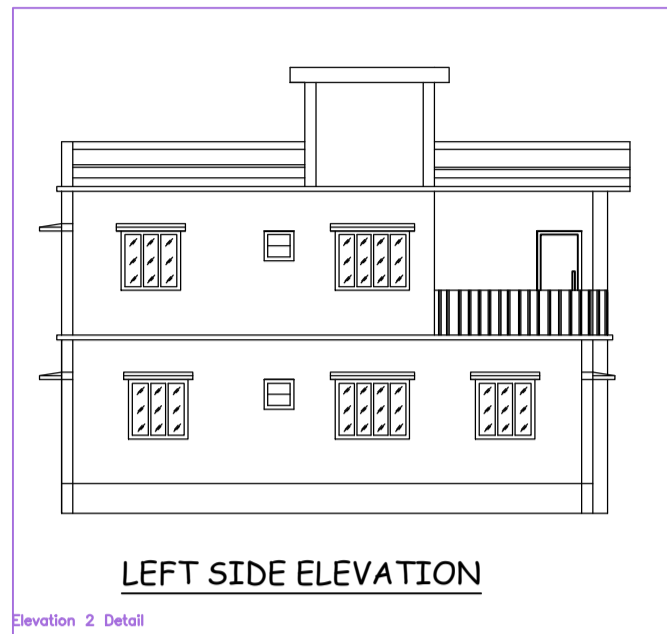
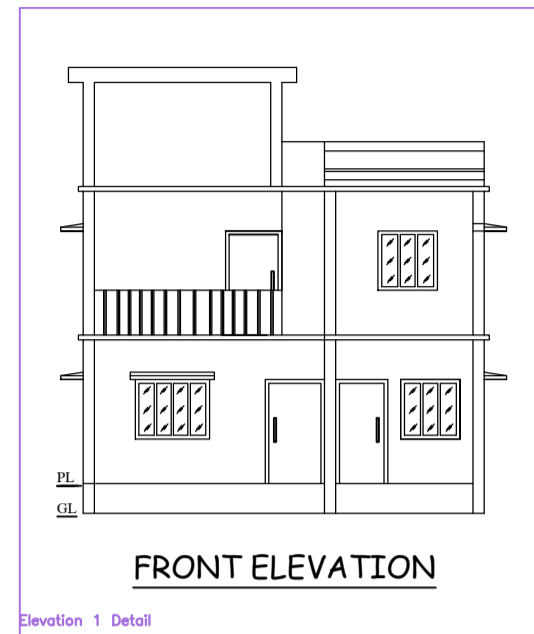
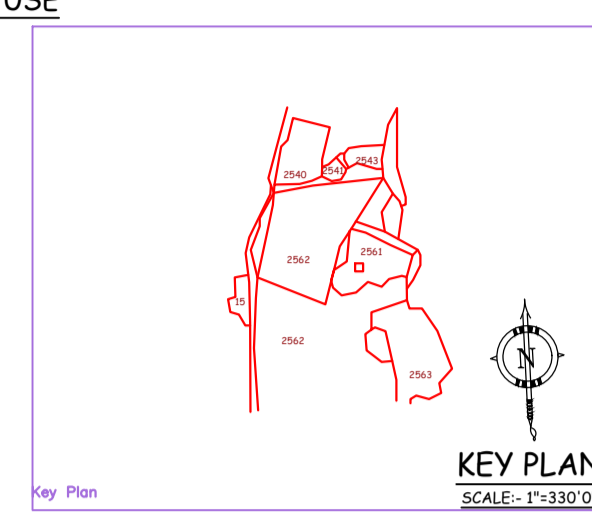

TITLE OF DRAWING

PROPOSED PLAN FOR, 1. SRI. SHANKAR DAS, S/O SRI. MADAN DAS, AND 2. SMT. DEWANTI DEVI, W/O SRI. SHANKAR DAS, AT PRESENT RESIDING AT, FLAT NO. 101, ANAND VIHAR, PHASE-II, CHIRA CHAS, PS.- CHAS, BOKARO (JHARKHAND) FOR RESIDENTIAL BUILDING AT, KHATA NO- 134, PLOT NO- 2561, AREA:-3.79 DECIMAL SITUATED AT MOUZA NO-0091, MAUZA -KHAMARBENDI, (CHAS), DISTRICT- BOKARO (J H A R K H A N D)

BRIEF SPECIFICATION

FOUNDATION..... CEMENT CONCRETE (1:3:6)  
 FOOTING..... R.C.C. (1:1½:3)  
 BRICK WORK IN FOUNDATION & SUPERSTRUCTURE  
 FIRST CLASS BRICK WORK IN CEMENT MORTAR (1:4)  
 D.P.C..... 1" D.P.C. IN CEMENT CONCRETE (1:2:4)  
 COLUMNS..... R.C.C. (1:1½:3)  
 FLOOR..... 1" I.P.S. OVER 3" P.C.C.  
 ROOF..... 4" THK R.C.C. ROOF (1:1½:3)  
 LINTEL..... 6" THK R.C.C. LINTEL (1:1½:3)  
 STAIRS..... RISE-- 6", TREAD-- 10"  
 DOORS..... D-3'3"x7'0", D1-3'0"x7'0", D2-2'6"x7'0"  
 WINDOWS..... W-5'0"x4'0", W1-4'0"x4'0", W2-2'6"x4'0"  
 VENTS..... V-2'0"x2'0"

SCHEDULE

D- 3'-6" X 7'-0" W- 5'-0" X 4'-0"  
 D1-3'-0" X 7'-0" W1- 4'-0" X 4'-0"  
 D2-2'-6" X 7'-0" W- 4'-0" X 2'-0"

DETAILS OF AREA

LAND AREA : 1650 Sft.  
 GROUND FLOOR AREA : 976.00 Sft.  
 FIRST FLOOR AREA : 976.00 Sft.  
 COVERED AREA : 1952.00 Sft.  
 % OF PLINTH AREA : 59.15%  
 F.A.R : 1.18

SIGN OF OWNER

SIGN OF ARCHITECT

ARCH. RAJ RANJAN SINGH

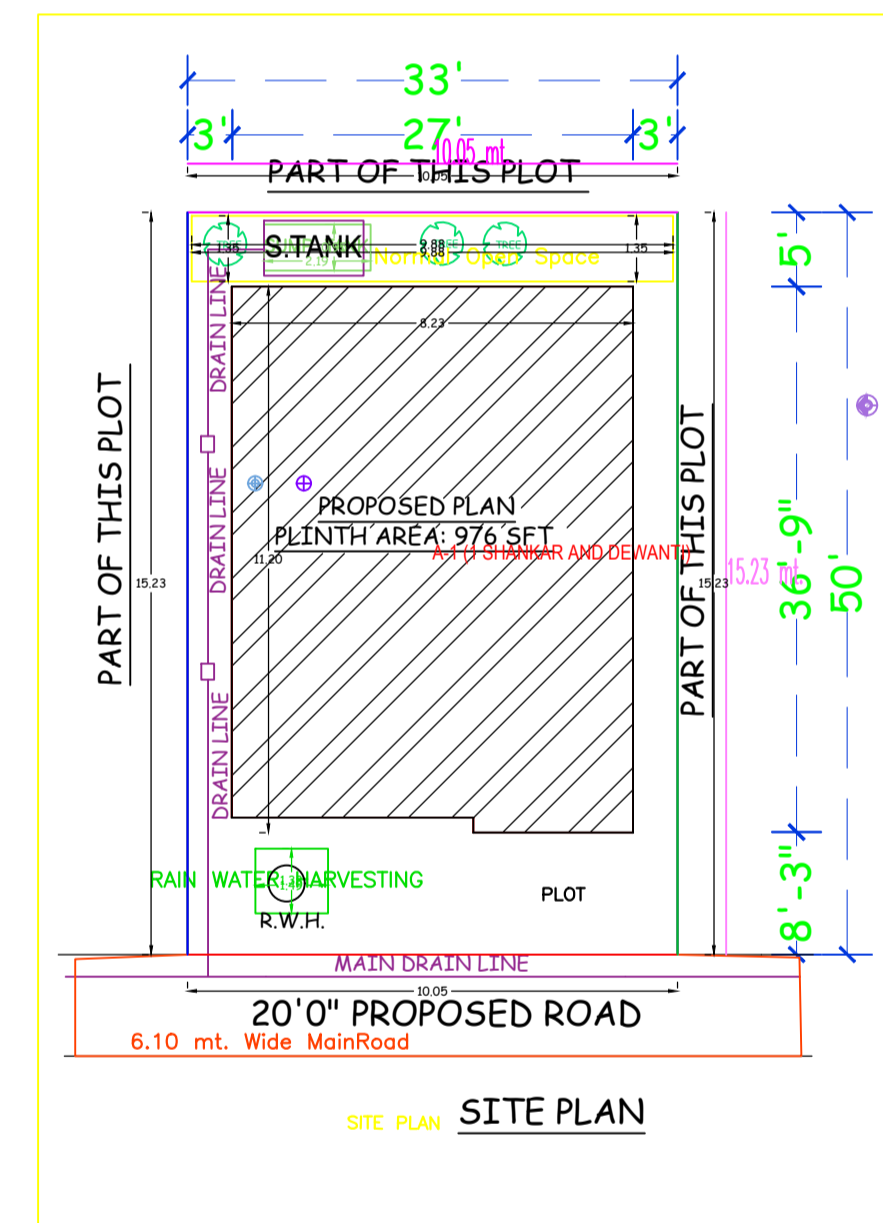
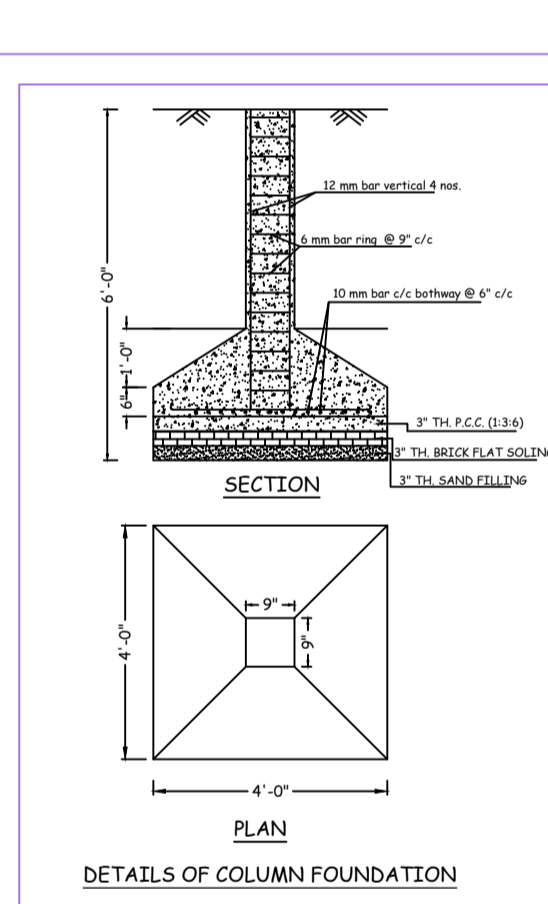
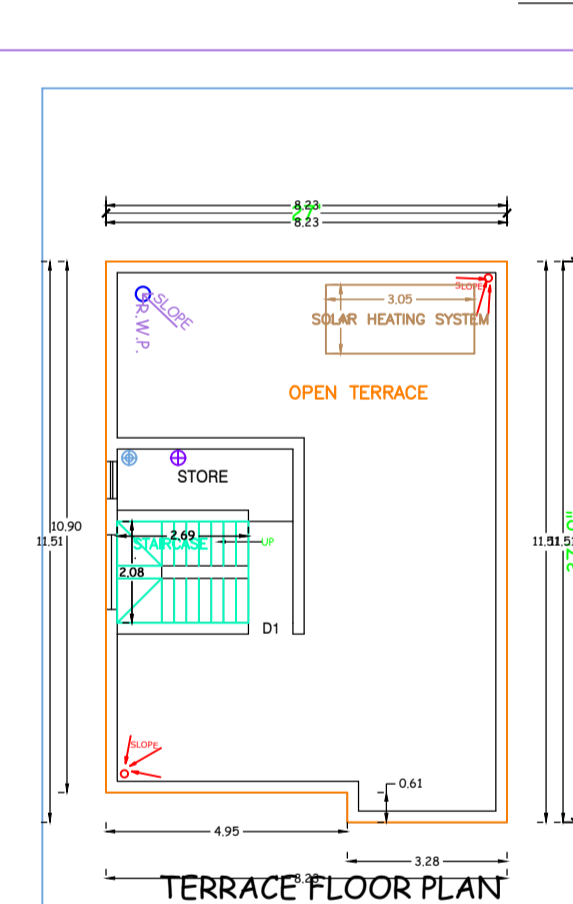
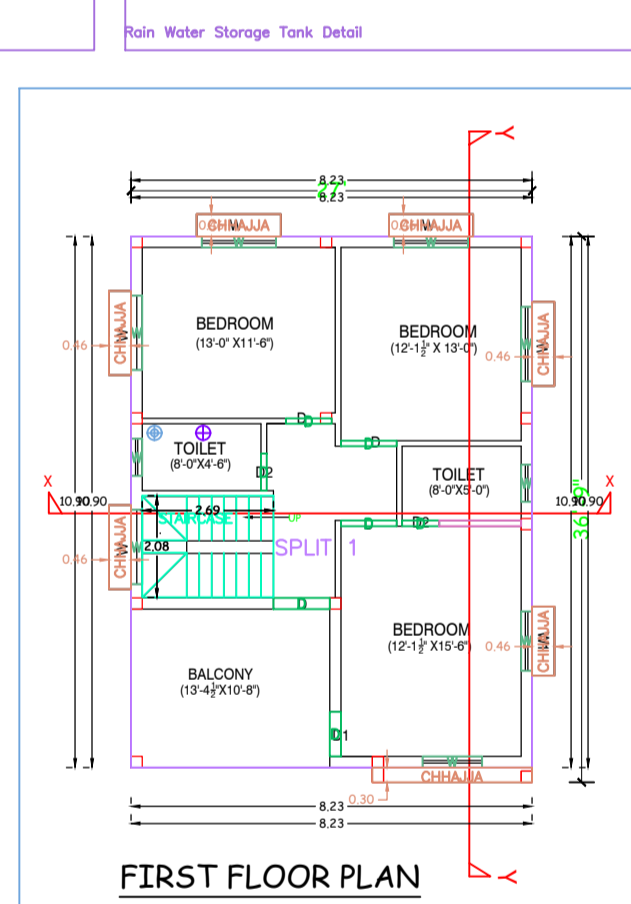
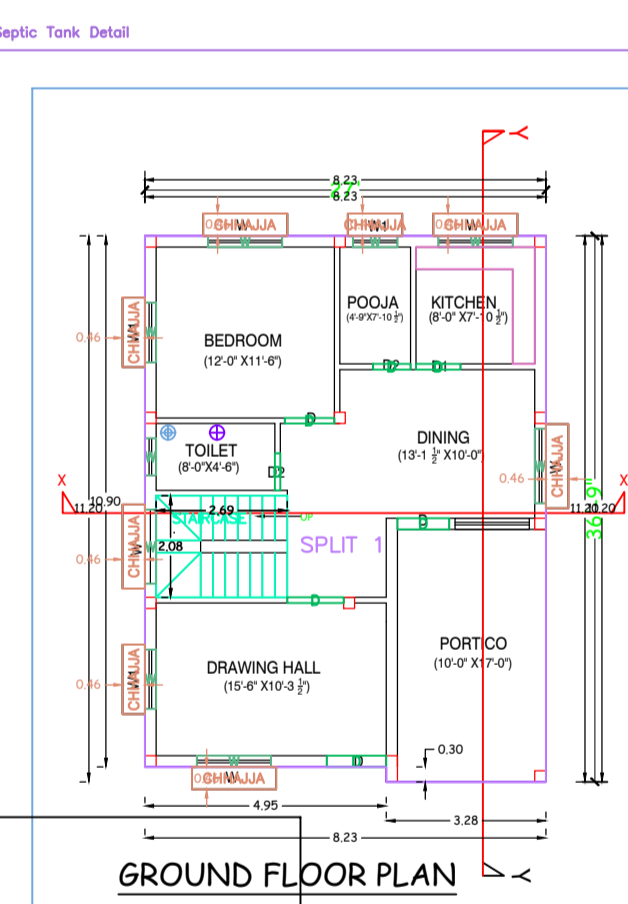
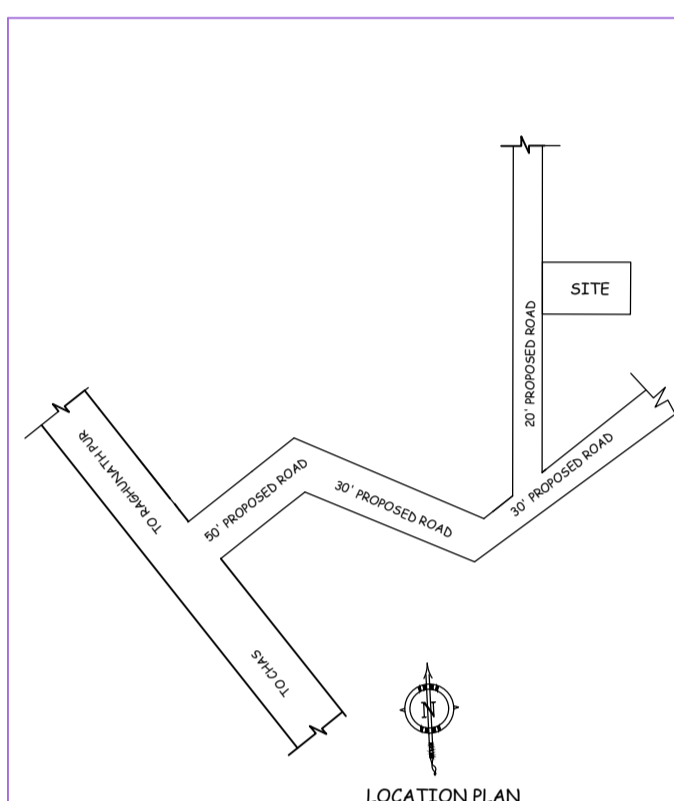
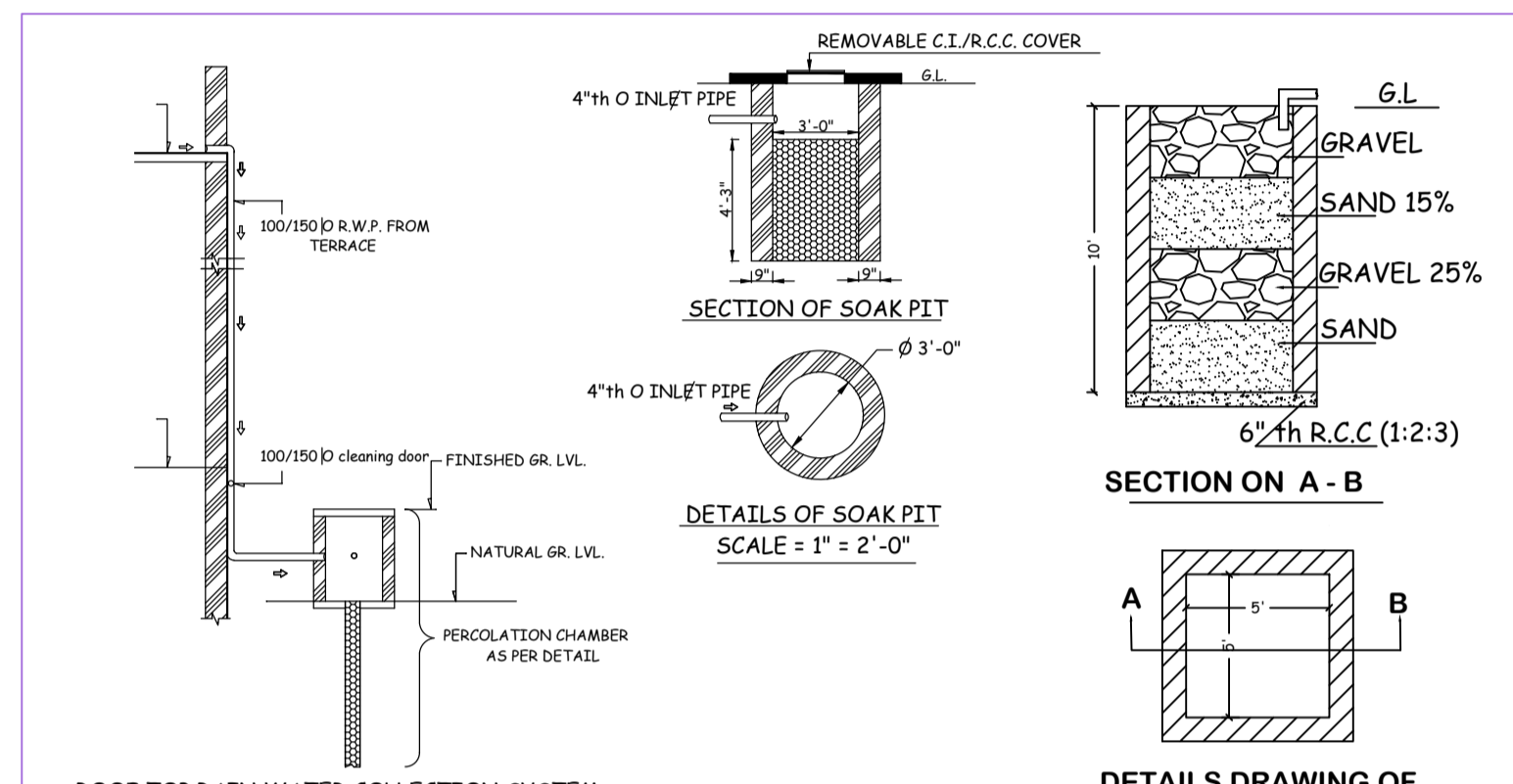
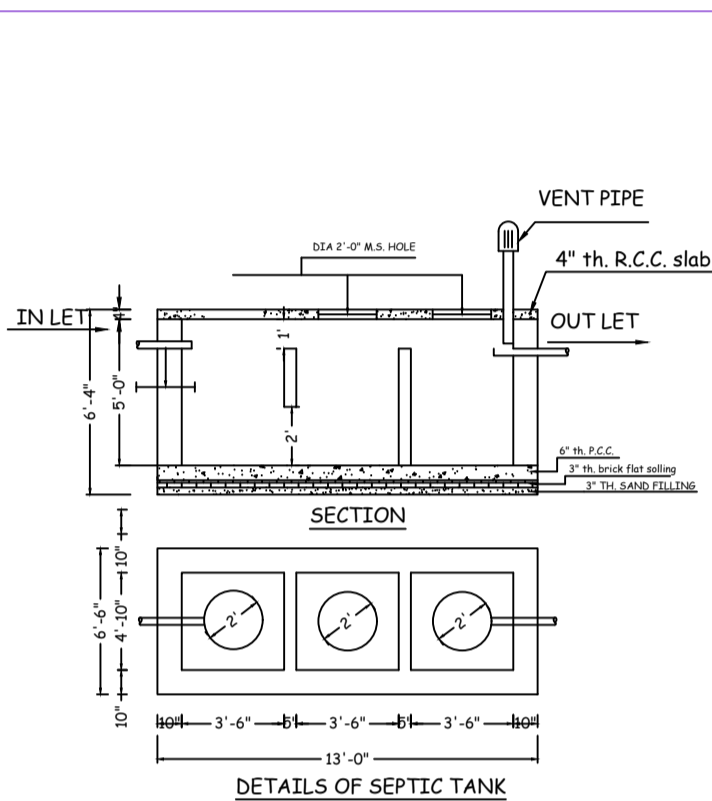

AREA STATEMENT MINERAL AREA DEVELOPMENT		VERSION NO. 1.0.36
AUTHORITY	PROJECT DETAIL	VERSION DATE: 16/10/2020
Plot No. : 2561	Plot Use : Residential	
Project : JHARKHAND URBAN LOCAL BODIES	Plot Sub-Use : Single/Dwelling / Non Apartment	
District : DHANBAD	Land Use Zone : RA	
Application Type : General Proposal	Abutting Road Width : -	
Project Type : Building Permission	Plot No. : -	
Nature of Development : New	Revenue Survey No/Survey No. : -	
Location : Old Area	Thana No. : -	
Site Location No. : -	Planning No. : -	
Village/Mauza Name : -	Khata No. : -	
Ward No. : -	North : -	
Phase/Sheet : -	South : -	
	East : -	
	West : -	

AREA DETAILS:		Area	SQ. MT.
AREA OF PLOT (Minimum)	(A)		153.03
Net Plot Area (Gross Plot Area - Deduction from Gross Plot Area)	(A-Deductions)		153.03
Deductions for Balance Plot Area (from Gross Plot Area)			13.29
Net Plot Area			139.74
Balance Plot Area (Net Plot Area - (Non-Developable Area))	(A-Deductions)		139.74
Plot Area for Coverage (Net Plot Area)	(A-Deductions)		153.03
Plot Area for FSI (Net Plot Area + (Non-Developable Area))	(A-Deductions)		153.03

FAR CHECK		Proposed FAR	Permitted FAR
Proposed Area of FAR		180.36	180.36
Total Area of FAR		180.36	180.36

BUILT UP AREA CHECK		Owner	180.36
Net Proposed Built Up Area			180.36
Architect/Engineer/Superintendent (Regd)			

DEVELOPMENT AUTHORITY		LOCAL BODY

COLOR INDEX	
Color Index:	
MARGIN DETAIL:	
Building / Wdg Name	Road Name
A (1) SHANKAR AND DEWANTI	6.10 mt. Wide Main Road
	Front Margin
	Rear Margin
	Side Margin
	Setback Margin
	0.91
	0.91

FAR & Tenement Details (Table 4c-1)					
Building	No. of Same Bldg	Total Built Up Area (Sq. mt.)	Proposed FAR Area (Sq. mt.)	Total FAR Area (Sq. mt.)	Tenant (No.)
A (1) SHANKAR AND DEWANTI	1	180.36	180.36	180.36	01
<b>Grand Total</b>	<b>1</b>	<b>180.36</b>	<b>180.36</b>	<b>180.36</b>	<b>01</b>

Building - A (1 SHANKAR AND DEWANTI)				
Floor Name	Total Built Up Area (Sq. mt.)	Proposed FAR Area (Sq. mt.)	Total FAR Area (Sq. mt.)	Tenant (No.)
Ground Floor	976.00	976.00	976.00	01
First Floor	976.00	976.00	976.00	01
Terrace Floor	0.00	0.00	0.00	00
<b>Total</b>	<b>1952.00</b>	<b>1952.00</b>	<b>1952.00</b>	<b>01</b>

SCHEDULE OF JOINERY:				
BUILDING NAME	NAME	LENGTH	HEIGHT	NO.
A (1) SHANKAR AND DEWANTI	D	0.76	2.10	04
A (1) SHANKAR AND DEWANTI	D	0.91	2.10	02
A (1) SHANKAR AND DEWANTI	D	0.94	2.10	01
A (1) SHANKAR AND DEWANTI	D	1.02	2.10	01
A (1) SHANKAR AND DEWANTI	D	1.07	2.10	01
A (1) SHANKAR AND DEWANTI	D	1.14	2.10	02
A (1) SHANKAR AND DEWANTI	D	1.16	2.10	02
A (1) SHANKAR AND DEWANTI	D	1.22	2.10	01
<b>Total</b>	-	-	-	<b>14</b>

SCHEDULE OF JOINERY:				
BUILDING NAME	NAME	LENGTH	HEIGHT	NO.
A (1) SHANKAR AND DEWANTI	W	0.76	1.20	03
A (1) SHANKAR AND DEWANTI	W	0.91	1.20	01
A (1) SHANKAR AND DEWANTI	W	1.22	1.20	04
A (1) SHANKAR AND DEWANTI	W	1.52	1.20	10
<b>Total</b>	-	-	-	<b>18</b>

UmBUA Table for Building - A (1 SHANKAR AND DEWANTI)						
FLOOR	Name	UmBUA Type	UmBUA Area	Carpet Area	No. of Rooms	No. of Tenement
GROUND FLOOR PLAN	SPLIT 1	PLAT	180.37	178.17	1	1
<b>Total</b>	-	-	<b>180.37</b>	<b>178.17</b>	<b>14</b>	<b>1</b>