

Building :RESI (GOPAL)

Floor Name	Total Built Up Area (Sq.mt.)	Proposed FAR Area (Sq.mt.)	Total FAR Area (Sq.mt.)	Total Consumed Additional FAR Area (Sq.mt.)	Tnmt (No.)
Ground Floor	97.85	97.85	97.85	97.85	01
First Floor	97.85	97.85	97.85	97.85	00
Terrace Floor	0.00	0.00	0.00	0.00	00
Total :	195.70	195.70	195.70	195.70	01
Total Number of Same Buildings	1				
Total :	195.70	195.70	195.70	195.70	01

SCHEDULE OF DOOR:

BUILDING NAME	NAME	LENGTH	HEIGHT	NOS
RESI (GOPAL)	D	0.76	2.10	02
RESI (GOPAL)	D	0.91	2.10	04
RESI (GOPAL)	D	0.95	2.10	01
RESI (GOPAL)	D	1.06	2.10	02
RESI (GOPAL)	D	1.07	2.10	01
RESI (GOPAL)	D	1.14	2.10	04
RESI (GOPAL)	D	1.22	2.10	01

SCHEDULE OF WINDOW/VENTILATION:

BUILDING NAME	NAME	LENGTH	HEIGHT	NOS
RESI (GOPAL)	W	0.61	1.20	02
RESI (GOPAL)	W	1.22	1.20	16
RESI (GOPAL)	W	1.60	1.20	02

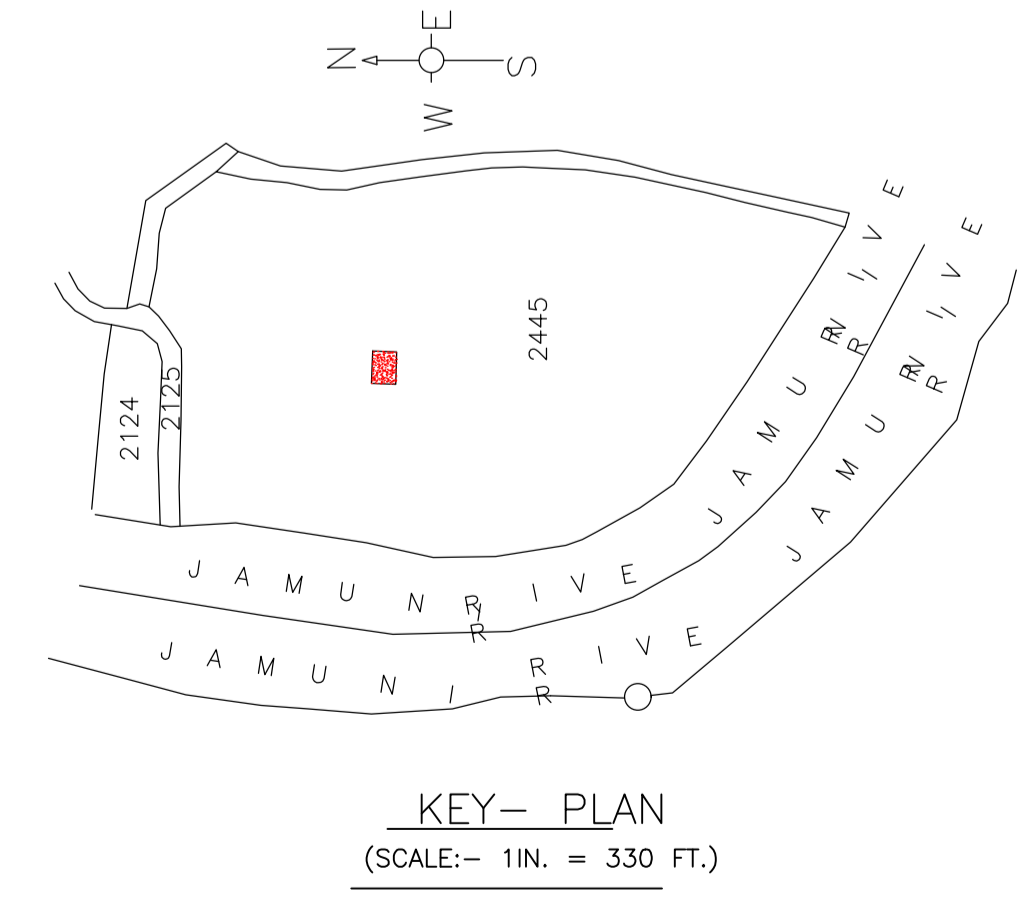
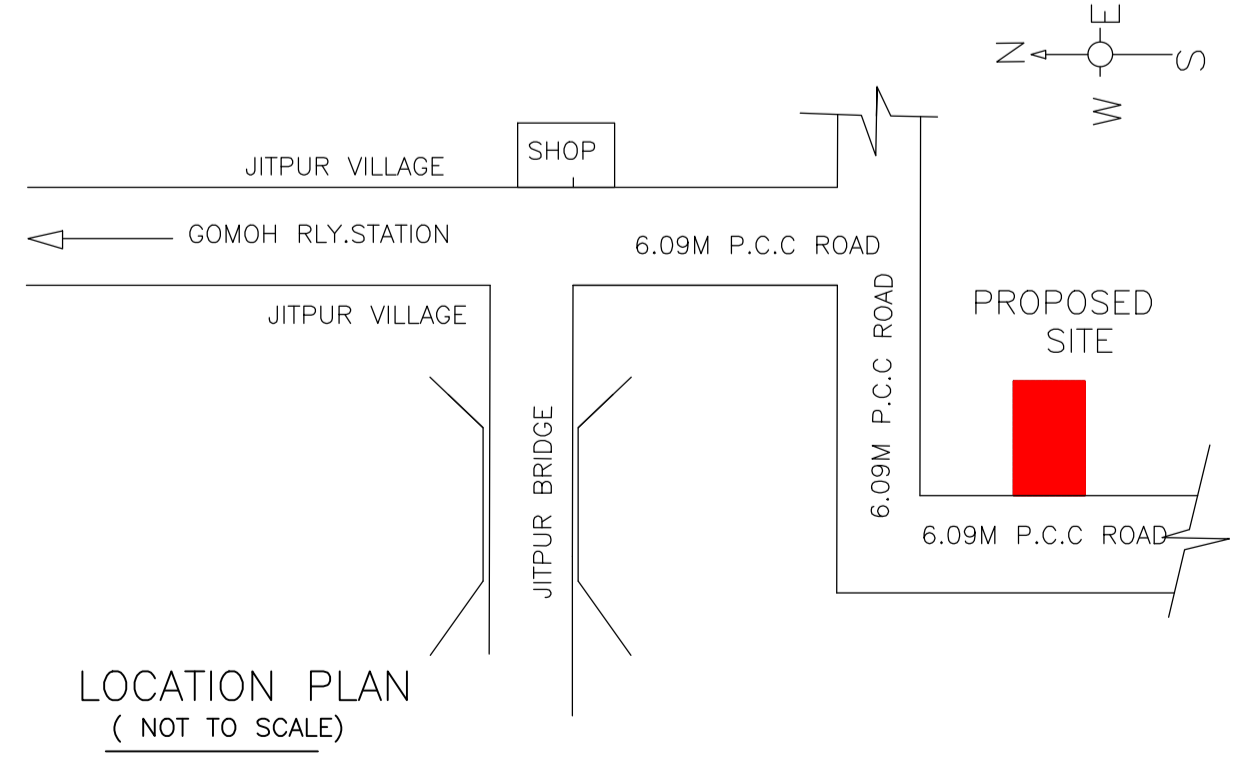

Proposal Basic Information

Proposal File No.	MADA/BP/0266/2023
Owner Name	SRI GOPAL KUMAR MUKHERJEE
Khata No.	09
Plot No.	2445
Village Name	Jeetpurr
Use	Residential
SubUse	Bungalow/ Dwelling / Non Apartment

AREA STATEMENT MINERAL

AREA DEVELOPMENT AUTHORITY	REGIONAL DEVELOPMENT AUTHORITY	VERSION NO. : 1.0.66	VERSION DATE: 16/10/2020
PROJECT DETAIL:			
Region: JHARKHAND URBAN LOCAL BODIES	Plot Use: Residential		
District: DHANBAD	Plot SubUse: Bungalow/ Dwelling / Non Apartment		
Authority: MINERAL AREA DEVELOPMENT AUTHORITY	PlotNearby/ReligiousStructure: NA		
Inward No: MADA/BP/0266/2023	Plot/SubPlot No: 2445		
Application Type: General Proposal	North: Plot No. - RAJESH RAM		
Project Type: Building Permission	South: Plot No. - ARBIND GUPTA		
Nature of Development: New	East: Road Width - 6.10		
Location of Development Area: Old Area	West: Plot No. - URMILA KUMARI MAHTO		
AREA DETAILS:			SQ.MT.
AREA OF PLOT (Minimum)	(A)		161.31
NET AREA OF PLOT(Gross Plot Area - Deduction from Gross Plot area)	(A-Deductions)		161.31
Deduction for Balance Plot Area(from Gross Plot Area)			
Common Plot			14.42
Total			14.42
BALANCE AREA OF PLOT(Net Plot Area - Recreational/Amenity space)	(A-Deductions)		146.89
PLOT AREA FOR COVERAGE(Net Plot Area)	(A-Deductions)		161.31
Plot Area for FAR (Net Plot Area + Road Widening Area)	(A-Deductions)		161.31
COVERAGE CHECK			
Permissible Coverage area (70.00 %)			112.92
Proposed Coverage Area (60.66 %)			97.85
Total Prop. Coverage Area (60.66 %)			97.85
Balance coverage area (9.34 %)			15.07
FAR CHECK			
Perm. FAR Area (2.500)			403.27
Total Perm. FAR area			403.27
Residential FAR			195.71
Proposed FAR Area			195.71
Total Proposed FAR Area			195.71
Consumed FAR (Factor)			1.21
Balance FAR Area			207.56
BUILT UP AREA CHECK			
Total Proposed BuiltUp Area			195.70
ARCHITECT (Regd)			Kumari Rinku Rani
ENGINEER (Regd)			
SUPERVISOR (Regd)			
OWNER (Regd)			SRI GOPAL KUMAR MUKHERJEE
DEVELOPMENT AUTHORITY			LOCAL BODY

Buildingwise Floor FAR Details

Floor Name	Building Name RESI (GOPAL)		Total	
	Proposed Built Up Area (Sq.mt.)	Proposed FAR Area (Sq.mt.)	Total Proposed Built Up Area (Sq.mt.)	Total FAR Area (Sq.mt.)
Ground Floor	97.85	97.85	97.85	97.85
First Floor	97.85	97.85	97.85	97.85
Terrace Floor	0.00	0.00	0.00	0.00
Total :	195.70	195.70	195.70	195.70

Building USE/SUBUSE Details

Building Name	Building Use	Building SubUse	Building Structure
RESI (GOPAL)	Residential	Bungalow/ Dwelling / Non Apartment	Non-Highrise

FAR & Tenement Details (Table 4c-1)

Building	No. of Same Bldg	Total Built Up Area (Sq.mt.)	Proposed FAR Area (Sq.mt.)	Total FAR Area (Sq.mt.)	Total Consumed Additional FAR Area (Sq.mt.)	Tnmt (No.)
RESI (GOPAL)	1	195.70	195.70	195.70	195.70	01
Grand Total :	1	195.70	195.70	195.70	195.70	01

UnitBUA Table for Building :RESI (GOPAL)

FLOOR	Name	UnitBUA Type	UnitBUA Area	Carpent Area	No. of Rooms	No. of Tenement
GROUND FLOOR PLAN	SPLIT 1	FLAT	195.71	192.99	8	1
FIRST FLOOR PLAN	SPLIT 1	FLAT	0.00	0.00	8	0
Total:	-	-	195.71	192.99	16	1

LTP NAME AND SIGNATURE Kumari Rinku Rani MADA/ENG/0001/2023	STRUCTURAL ENG'S NAME AND SIGNATURE	BUILDER NAME AND SIGNATURE	DIGITAL SIGNATURE
-------------------------------------------------------------------	-------------------------------------	----------------------------	-------------------

Proposal Basic Information	
Proposal File No.	MADA/BP/0266/2023
Owner Name	SRI GOPAL KUMAR MUKHERJEE
Khata No	09
Plot No	2445
Village Name	Jeetpurr
Use	Residential
SubUse	Bungalow/ Dwelling / Non Apartment

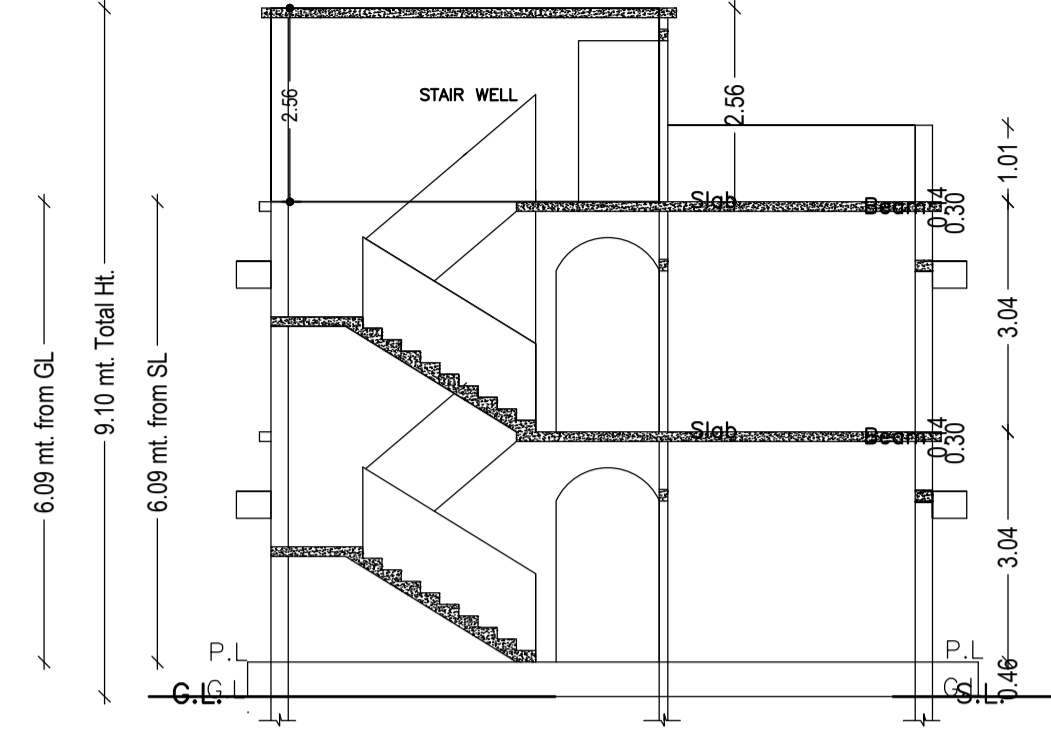
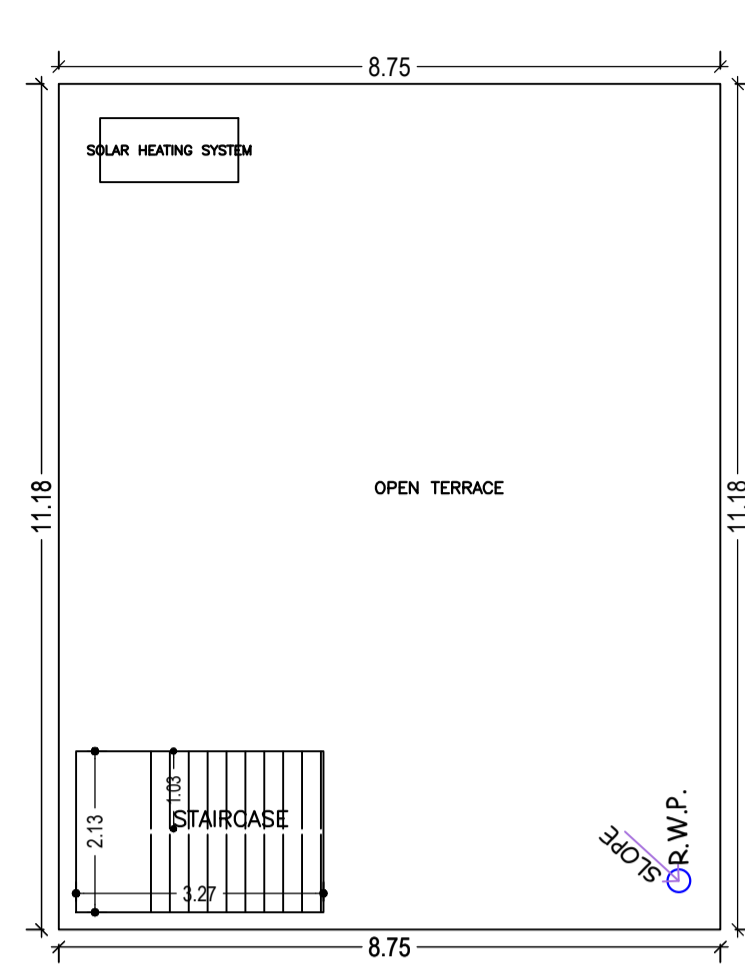
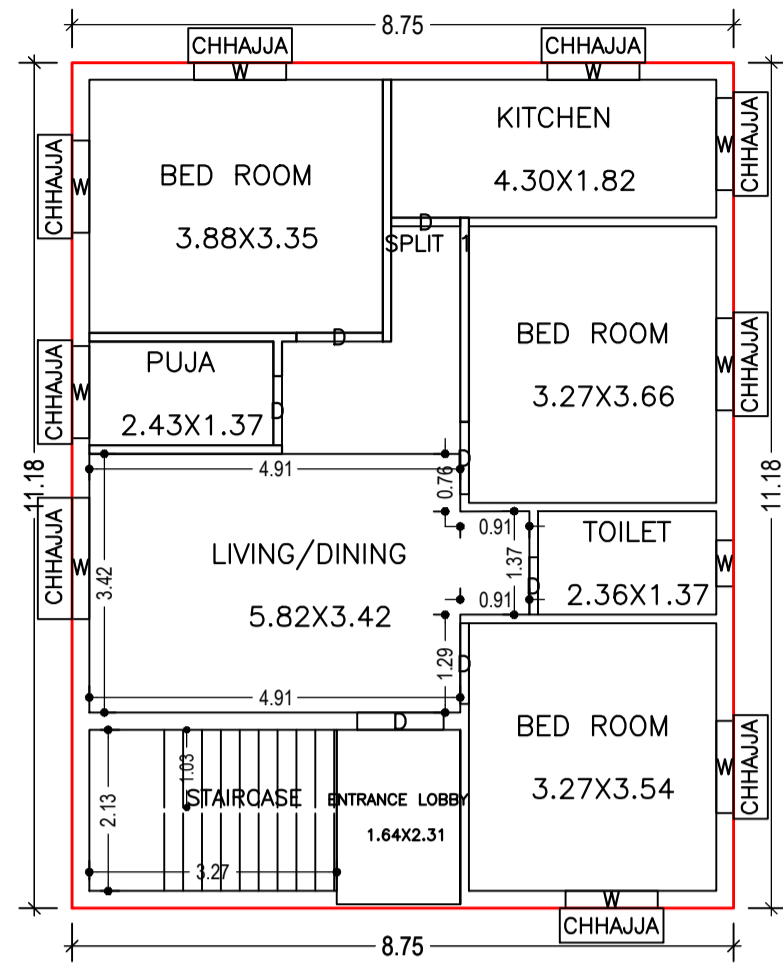
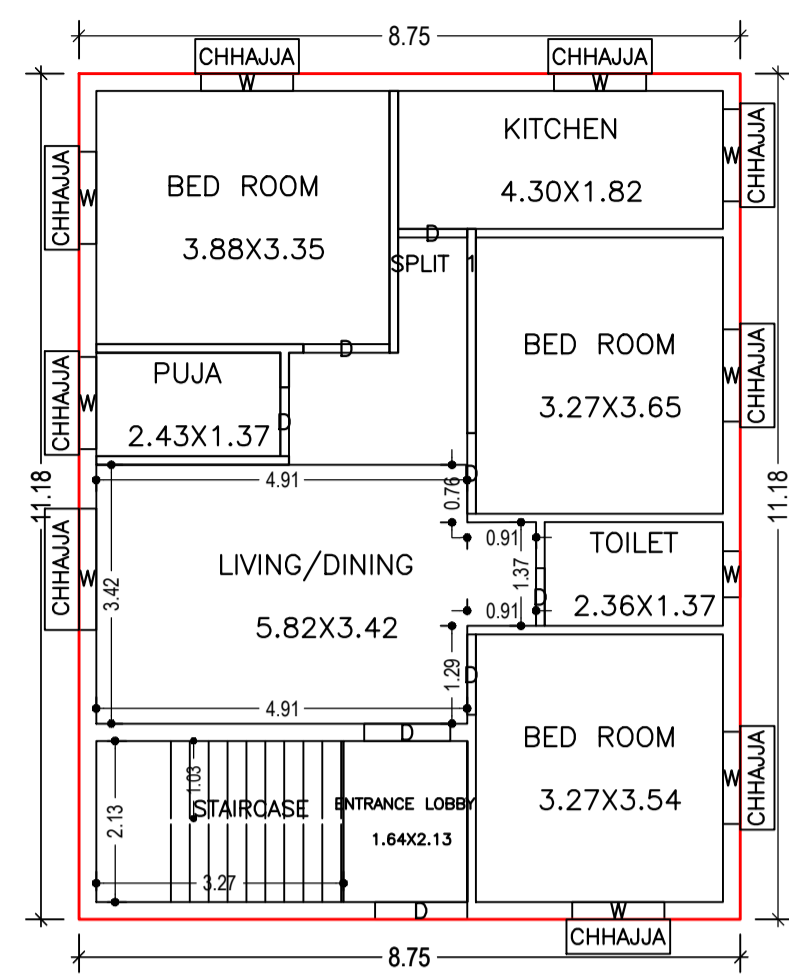

SECTION AT X-X

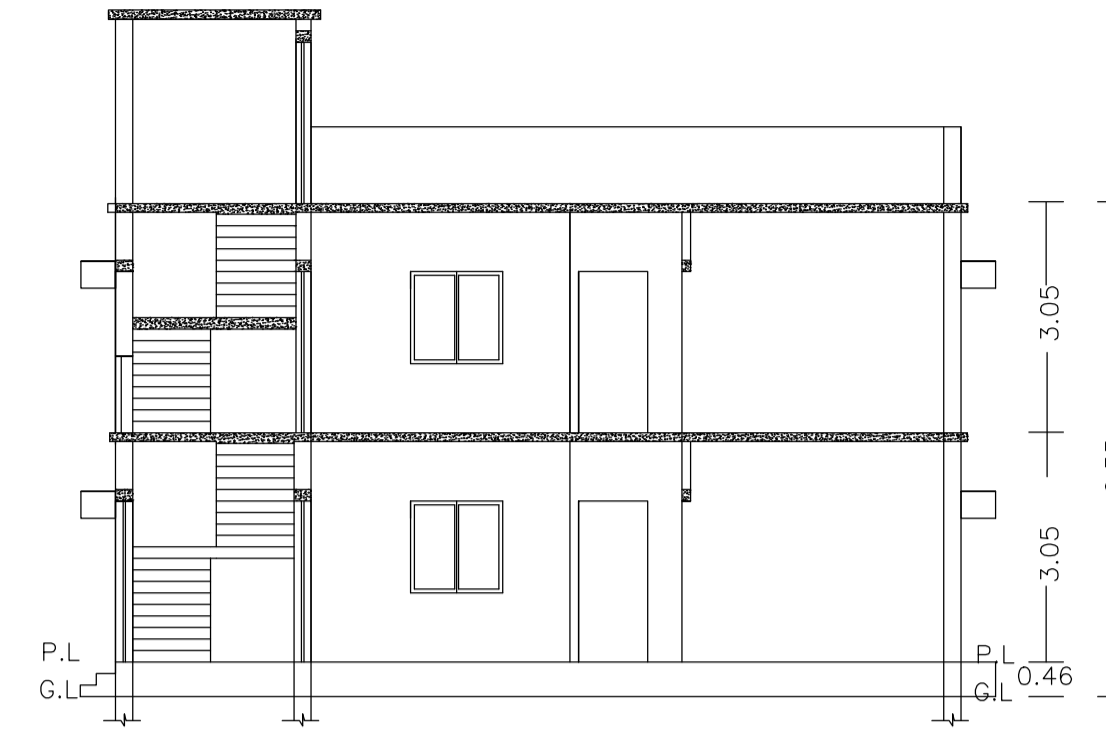

SECTION AT Y-Y

GROUND FLOOR PLAN (Proposed) (SCALE 1:100)

FIRST FLOOR PLAN (Proposed) (SCALE 1:100)

TERRACE FLOOR PLAN (SCALE 1:100)

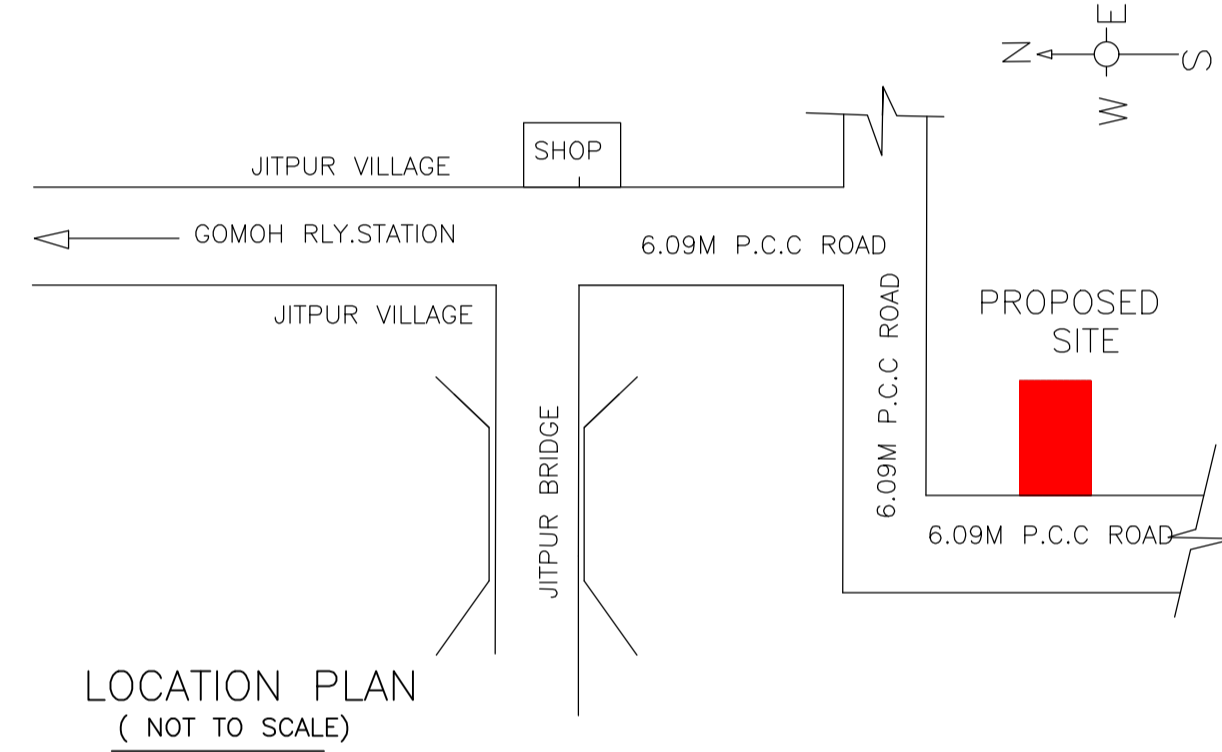

LOCATION PLAN (NOT TO SCALE)

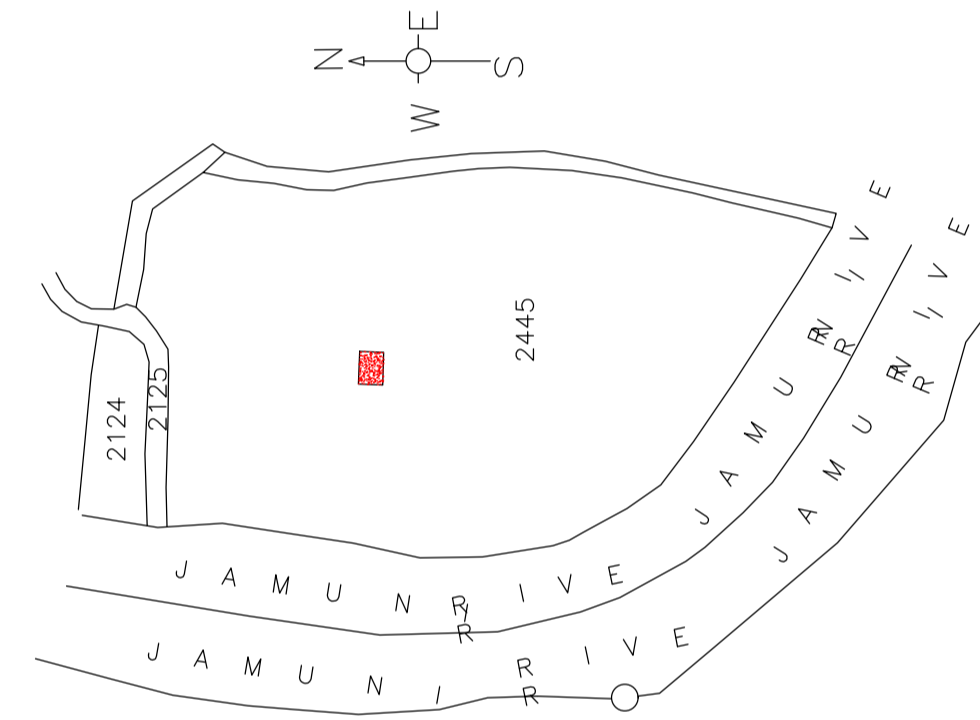

KEY-PLAN (SCALE:- 1IN. = 330 FT.)



FRONT ELEVATION

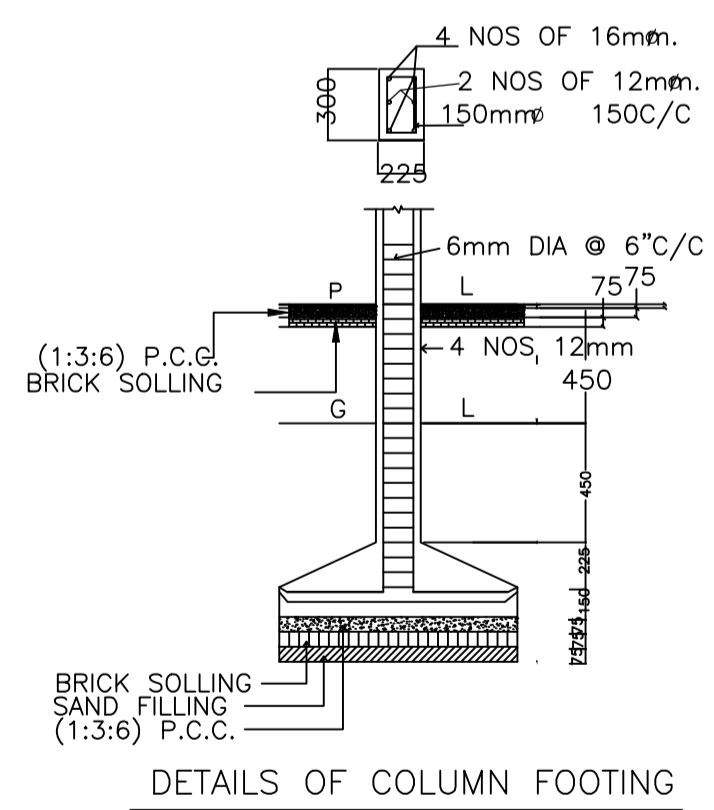

DETAILS OF COLUMN FOOTING

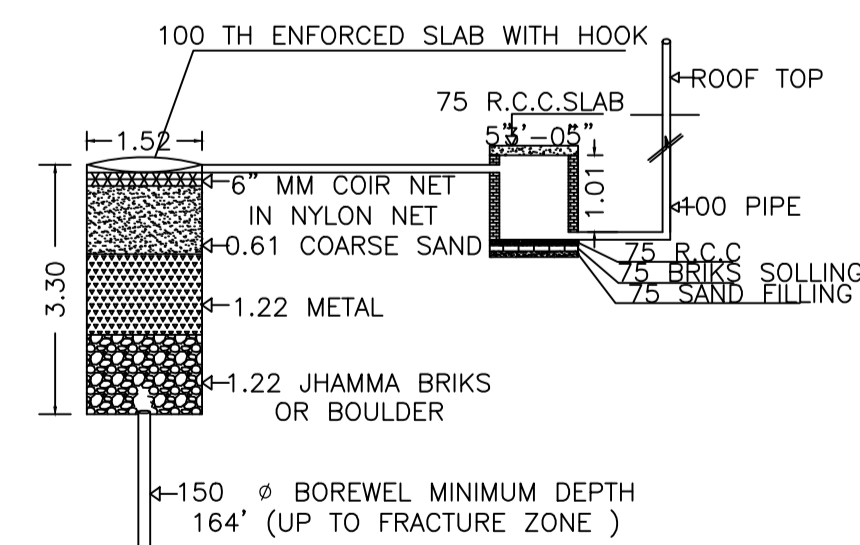

DETAIL OF GROUND WATER RECHARGING PIT WITH SILT TANK

NOT TO SCALE

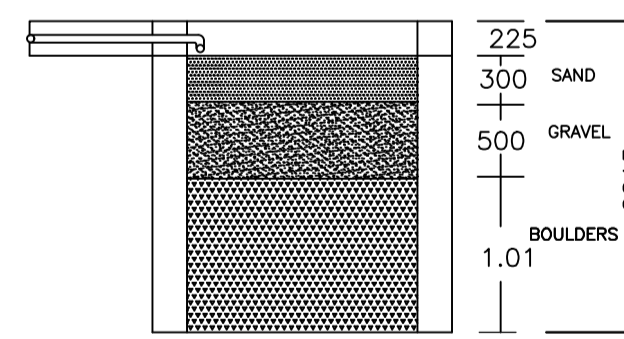

SECTION

PLAN OF RAIN WATER HARVESTING

(SCALE:-1:25)

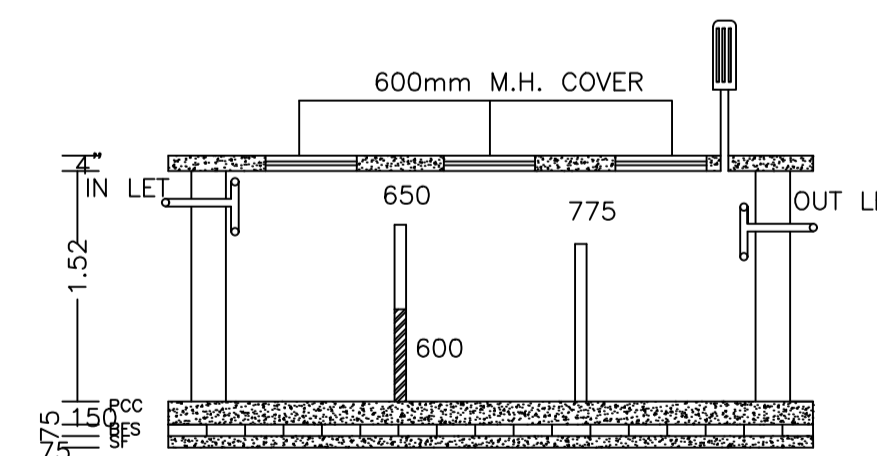

SECTION

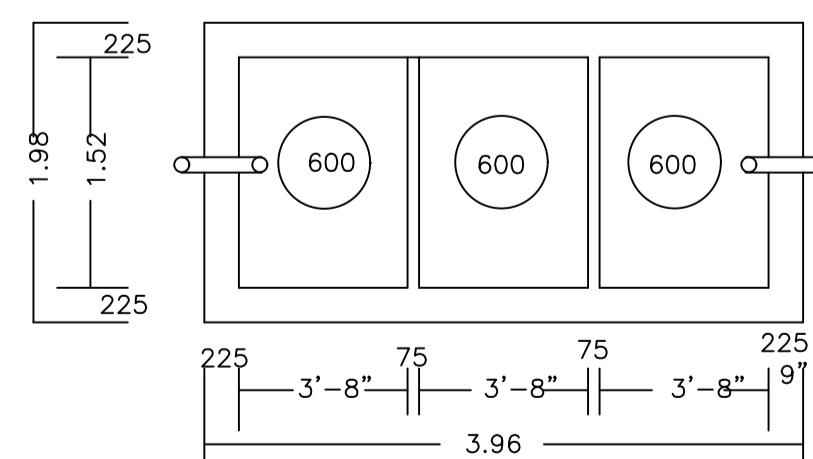

PLAN OF SEPTIC TANK

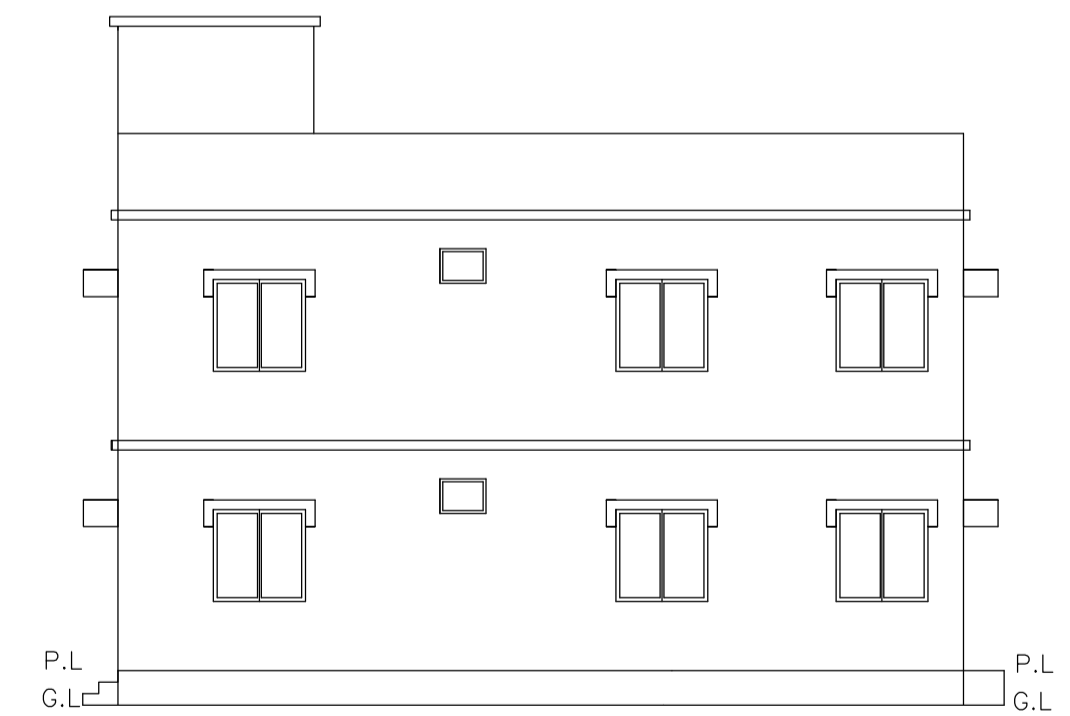

RIGHT SIDE ELEVATION

PLAN DETAILS OF COLUMNS (SCALE:- 1:50)

LTP NAME AND SIGNATURE	STRUCTURAL ENG'S NAME AND SIGNATURE	BUILDER NAME AND SIGNATURE	DIGITAL SIGNATURE
Kumari Rinku Rani MADA/ENG/0001/2023			