

Proposal Basic Information

Proposal File No.	MADA/BP/0272/2023
Owner Name	SMT KUMARI PUNAM PATHAK
Khata No	NEW -140, OLD -7.27
Plot No	NEW -2770, OLD -37.38
Village Name	Narayanpur
Use	Residential
SubUse	Bungalow/ Dwelling / Non Apartment

AREA STATEMENT MINERAL AREA DEVELOPMENT AUTHORITY	VERSION NO.: 1.0.66	VERSION DATE: 16/10/2020
PROJECT DETAIL:	Region: JHARKHAND URBAN LOCAL BODIES	Plot Use: Residential
Authority: MINERAL AREA DEVELOPMENT AUTHORITY	Plot SubUse: Bungalow/ Dwelling / Non Apartment	PlotNearbyReligiousStructure: NA
Inward No: MADA/BP/0272/2023	North: Plot No. - NATRAJ APARTMENT	Plot/SubPlot No: NEW -2770, OLD -37.38
Application Type: General Proposal	South: Road Width - 4.57M WIDE ROAD	Project Type: Building Permission
Nature of Development: New	East: Road Width - 6.1 M WIDE ROAD	Location of Development Area: Old Area
West: Plot No. - UTTARA VISHWAS		
AREA OF PLOT (Minimum)	(A)	SQ.MT. 362.26
NET AREA OF PLOT (Gross Plot Area - Deduction from Gross Plot area)	(A-Deductions)	362.26
Deduction for Balance Plot Area (from Gross Plot Area)		
Common Plot		20.04
Total		20.04
BALANCE AREA OF PLOT (Net Plot Area - Recreational/Amenity space)	(A-Deductions)	342.22
PLOT AREA FOR COVERAGE (Net Plot Area)	(A-Deductions)	362.26
Plot Area for FAR (Net Plot Area + Road Widening Area)	(A-Deductions)	362.26
COVERAGE CHECK		
Permissible Coverage area (60.00 %)		217.36
Proposed Coverage Area (39.67 %)		143.71
Total Prop. Coverage Area (39.67 %)		143.71
Balance coverage area (20.33 %)		73.65
FAR CHECK		
Perm. FAR Area (2.500)		905.65
Total Perm. FAR area		905.65
Residential FAR		293.51
Proposed FAR Area		293.51
Total Proposed FAR Area		293.51
Consumed FAR (Factor)		0.81
Balance FAR Area		612.14
BUILT UP AREA CHECK		
Total Proposed BuiltUp Area		299.60
ARCHITECT (Regd)		KUSHJEE PANDEY
ENGINEER (Regd)		
SUPERVISOR (Regd)		
OWNER (Regd)		SMT KUMARI PUNAM PATHAK
DEVELOPMENT AUTHORITY		LOCAL BODY

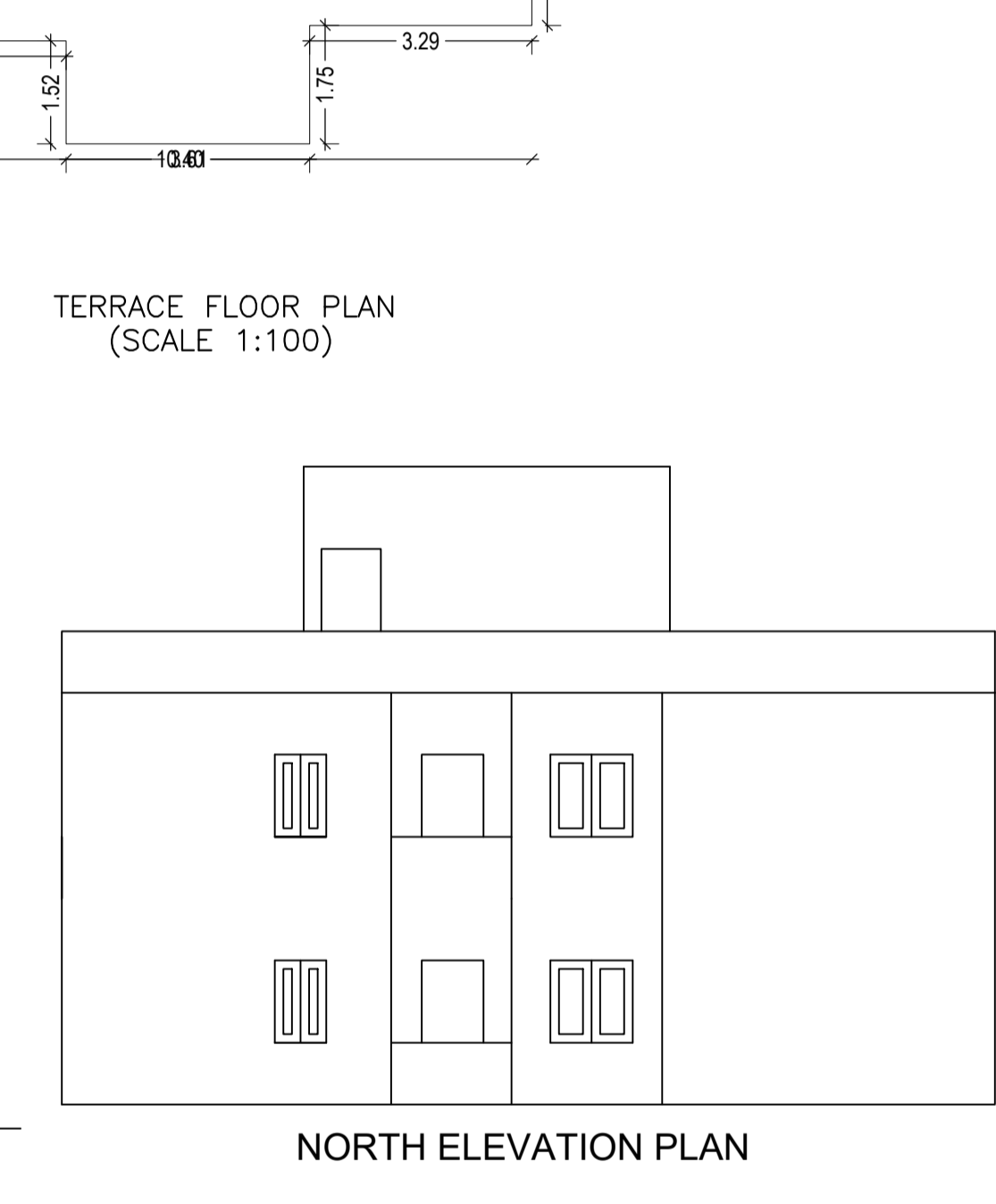
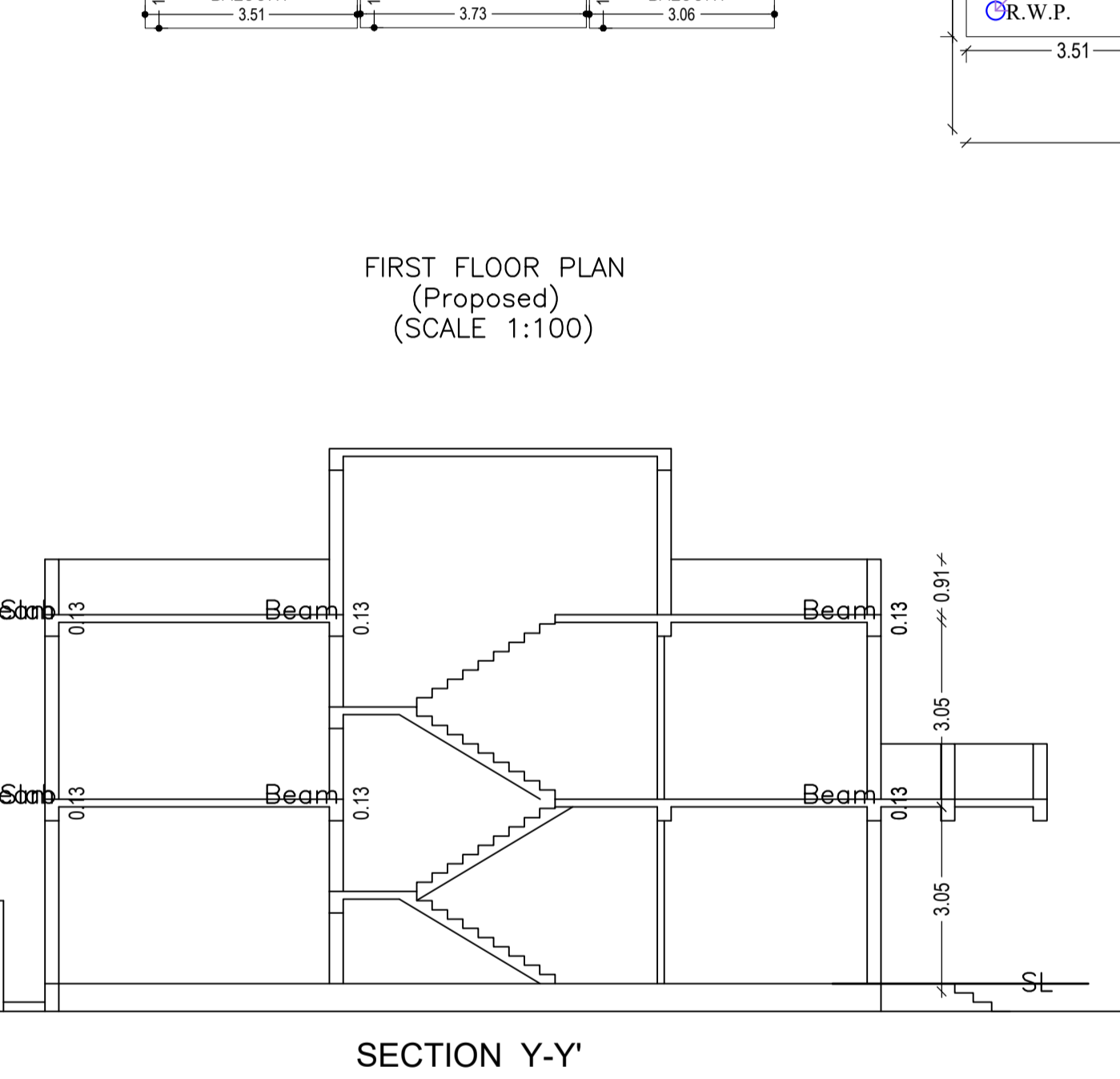
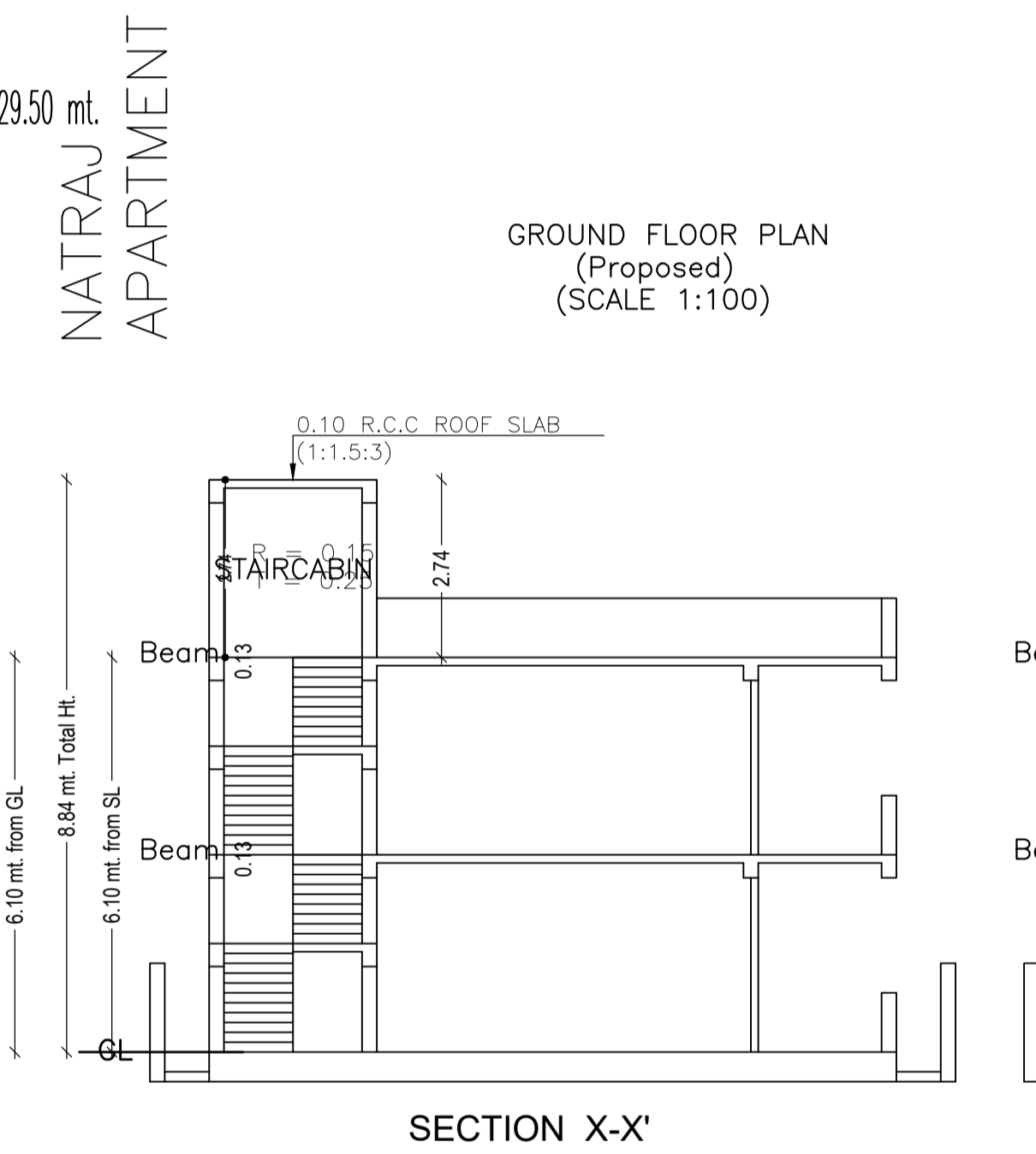

Building :AB (EG)

Floor Name	Total Built Up Area (Sq.mt.)	Deductions (Area in Sq.mt.)		Proposed FAR Area (Sq.mt.)	Total FAR Area (Sq.mt.)	Total Consumed Additional FAR Area (Sq.mt.)	Trmt (No.)
		Balcony	Resi.				
Ground Floor	143.71	0.00	143.71	143.71	143.71	01	
First Floor	155.89	6.09	149.80	149.80	149.80	00	
Terrace Floor	0.00	0.00	0.00	0.00	0.00	00	
Total:	299.60	6.09	293.51	293.51	293.51	01	
Total Number of Same Buildings	1						
Total:	299.60	6.09	293.51	293.51	293.51	01	

SCHEDULE OF DOOR:

BUILDING NAME	NAME	LENGTH	HEIGHT	NOS
AB (EG)	D	0.76	2.10	06
AB (EG)	D	0.91	2.10	13
AB (EG)	D	1.07	2.10	01
AB (EG)	D	1.22	2.10	01
AB (EG)	D	1.37	2.10	01
AB (EG)	D	1.52	2.10	01
AB (EG)	D	1.83	2.10	01

SCHEDULE OF WINDOW/VENTILATION:

BUILDING NAME	NAME	LENGTH	HEIGHT	NOS
AB (EG)	W	0.61	1.20	04
AB (EG)	W	0.76	1.20	02
AB (EG)	W	1.07	1.20	01
AB (EG)	W	1.22	1.20	02
AB (EG)	W	1.31	1.20	01
AB (EG)	W	1.52	1.20	07
AB (EG)	W	1.82	1.20	01

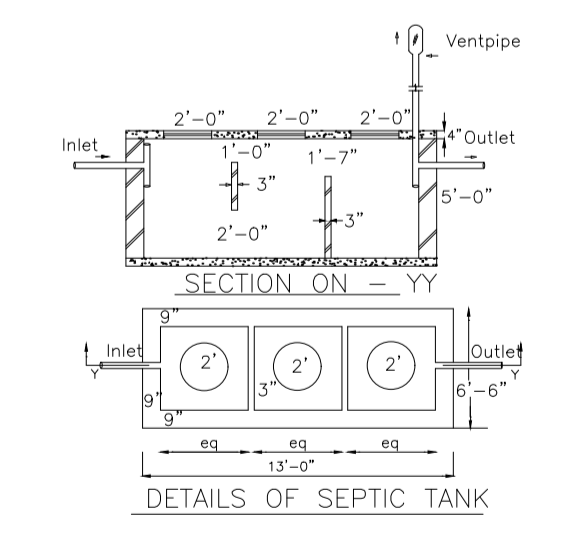
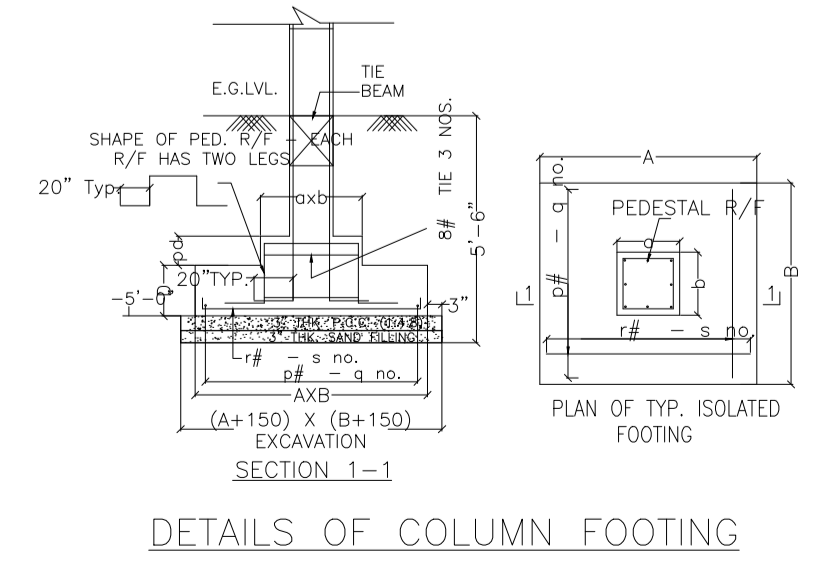
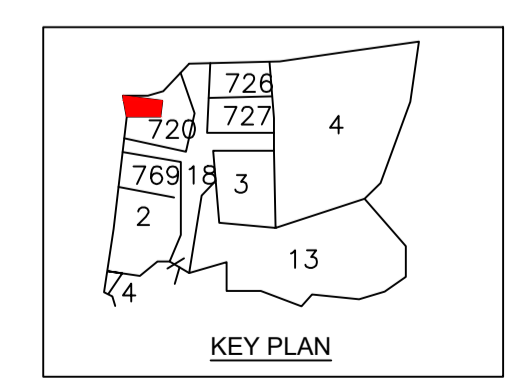
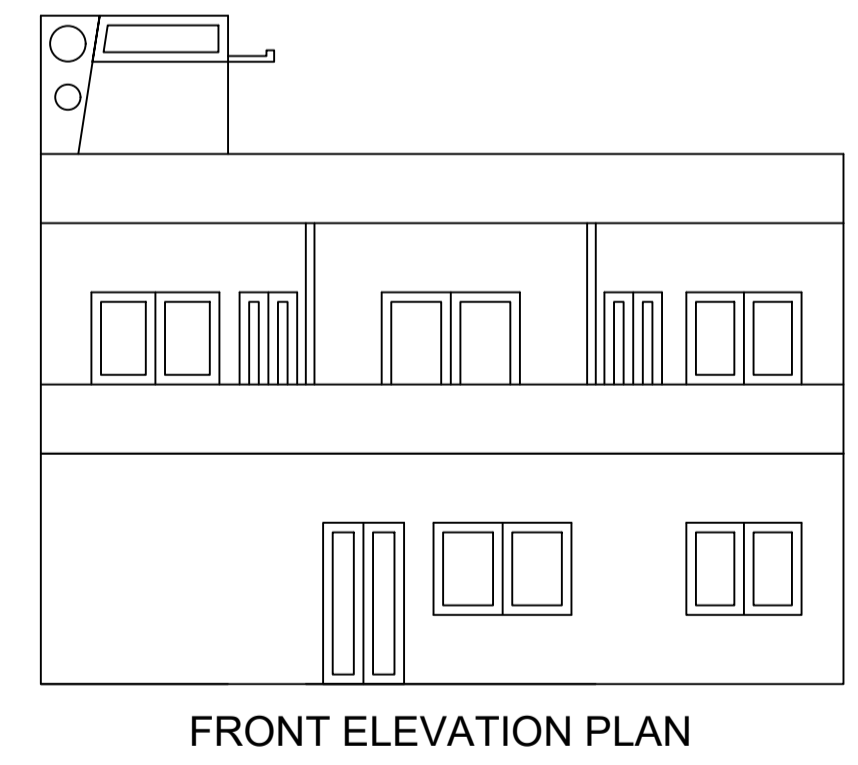
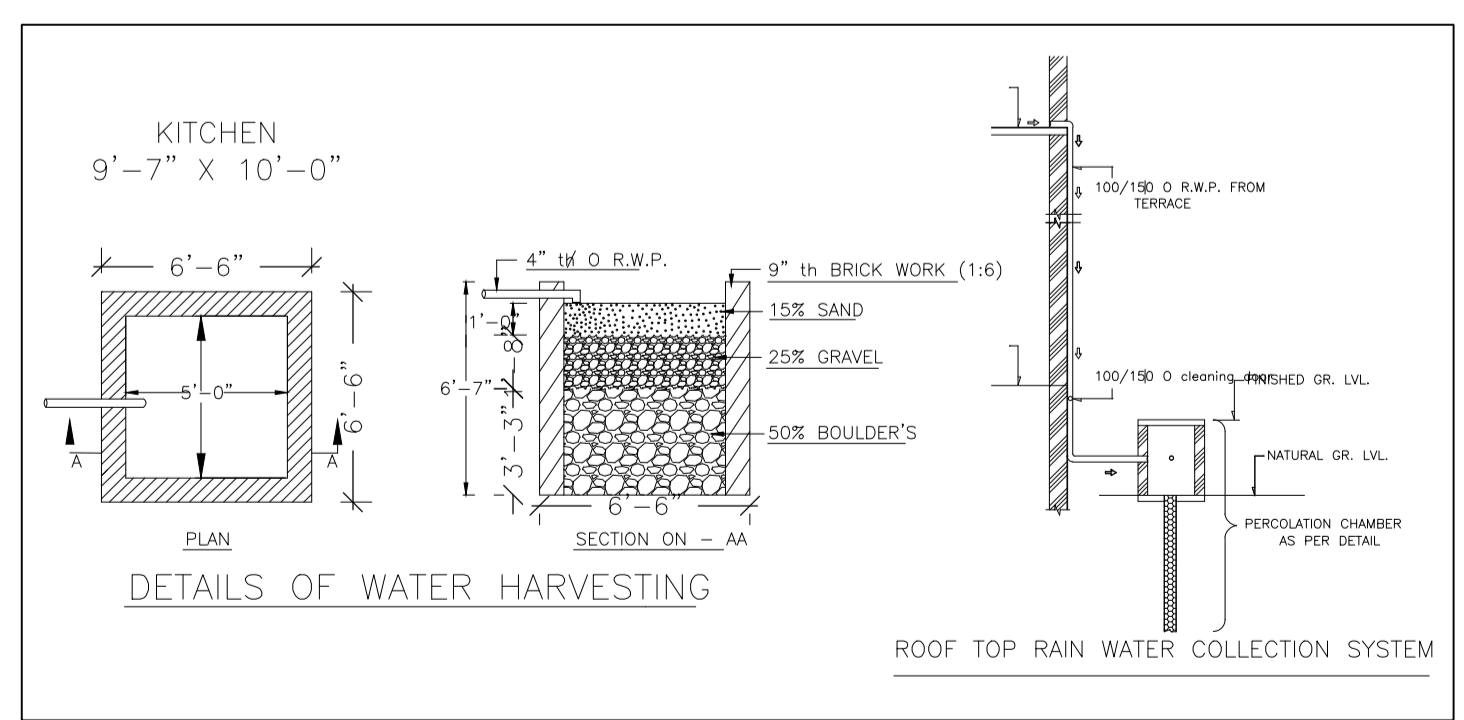

COLOR INDEX

PLOT BOUNDARY	Black
ABUTTING ROAD	Red
PROPOSED CONSTRUCTION	Green
COMMON PLOT	Yellow
ROAD WIDENING AREA	Blue
EXISTING (To be retained)	White
EXISTING (To be demolished)	Grey

Buildingwise Floor FAR Details

Floor Name	Building Name		Total	
	Proposed Built Up Area (Sq.mt.)	Proposed FAR Area (Sq.mt.)	Total Proposed Built Up Area (Sq.mt.)	Total FAR Area (Sq.mt.)
Ground Floor	143.71	143.71	143.71	143.71
First Floor	155.89	149.80	155.89	149.80
Terrace Floor	0.00	0.00	0.00	0.00
Total:	299.60	293.51	299.60	293.51

Building USE/SUBUSE Details

Building Name	Building Use	Building SubUse	Building Structure
AB (EG)	Residential	Bungalow/ Dwelling / Non Apartment	Non-Highrise

FAR & Tenement Details (Table 4c-1)

Building	No. of Same Bldg	Total Built Up Area (Sq.mt.)	Deductions (Area in Sq.mt.)		Proposed FAR Area (Sq.mt.)	Total FAR Area (Sq.mt.)	Total Consumed Additional FAR Area (Sq.mt.)	Trmt (No.)
			Balcony	Resi.				
AB (EG)	1	299.60	6.09	293.51	293.51	293.51	293.51	01
Grand Total:	1	299.60	6.09	293.51	293.51	293.51	293.51	01

Balcony Calculations Table

FLOOR	SIZE	AREA	TOTAL AREA
FIRST FLOOR PLAN	1.19 X 3.51 X 1 X 1	4.16	12.18
	1.18 X 3.73 X 1 X 1	4.40	
	1.18 X 3.06 X 1 X 1	3.62	
Total			12.18

LTP NAME AND SIGNATURE	STRUCTURAL ENG'S NAME AND SIGNATURE	BUILDER NAME AND SIGNATURE	DIGITAL SIGNATURE
KUSHJEE PANDEY MADA/ARC/0027/2019			