

**SITE PLAN**  
SCALE - 1" = 16'-0"

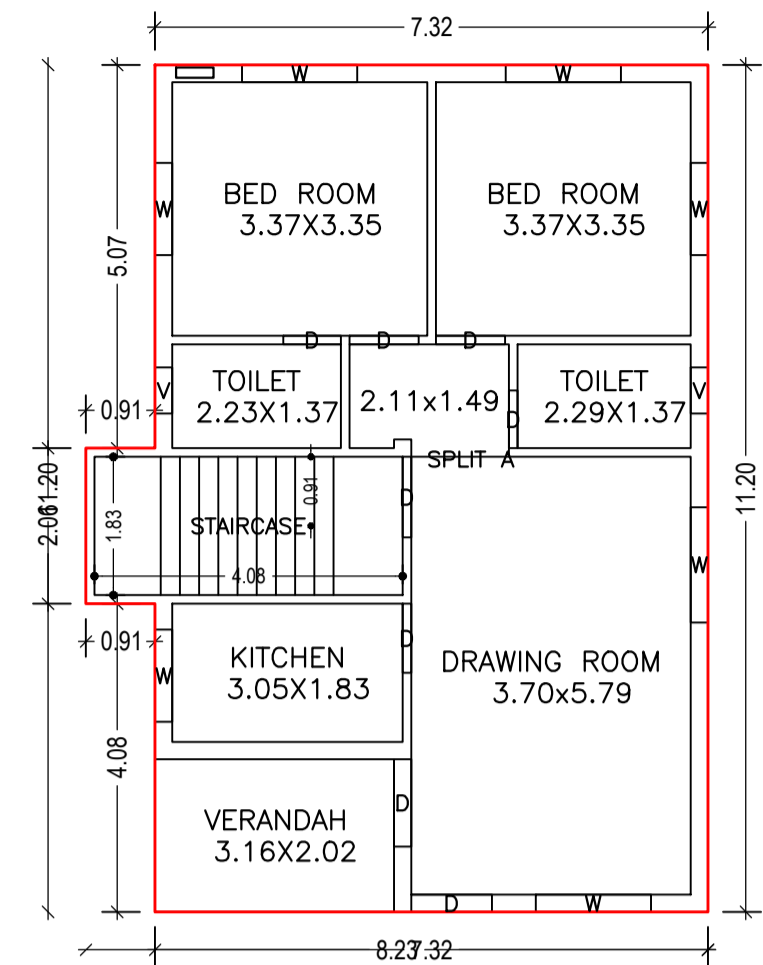

**GROUND FLOOR PLAN (Proposed)**  
SCALE 1:100

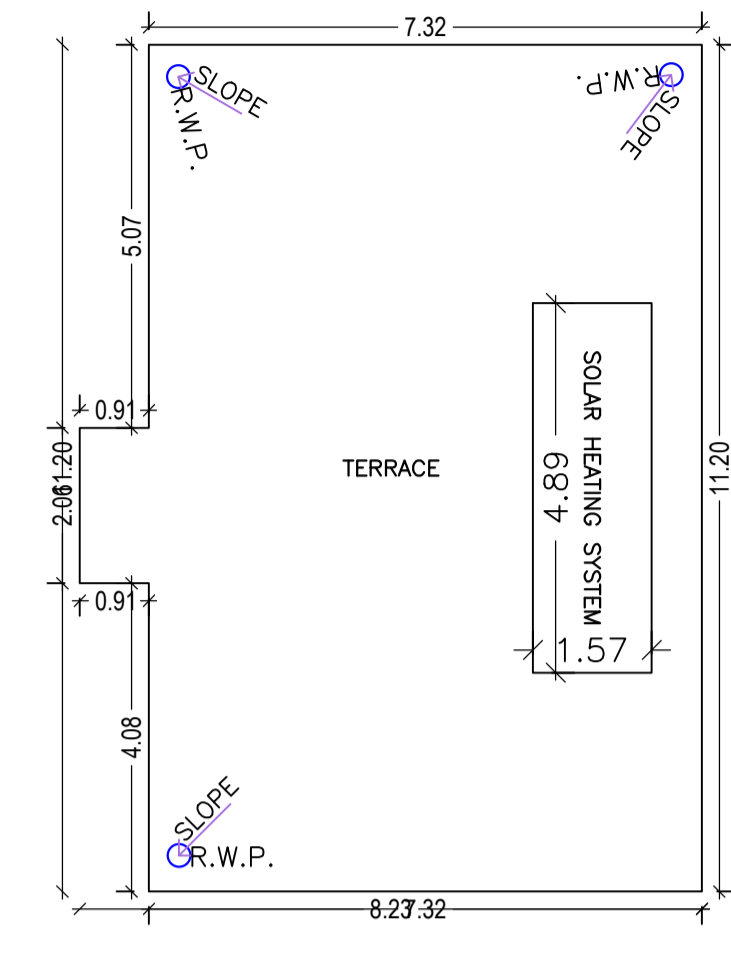

**TERRACE FLOOR PLAN**  
SCALE 1:100

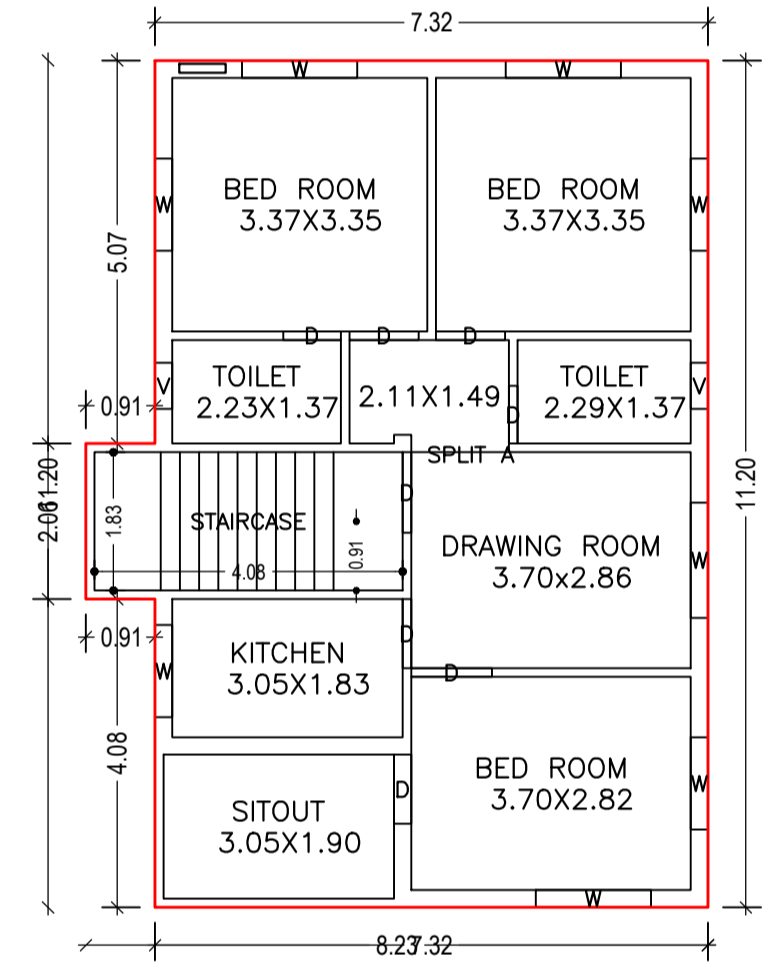

**FIRST FLOOR PLAN (Proposed)**  
SCALE 1:100

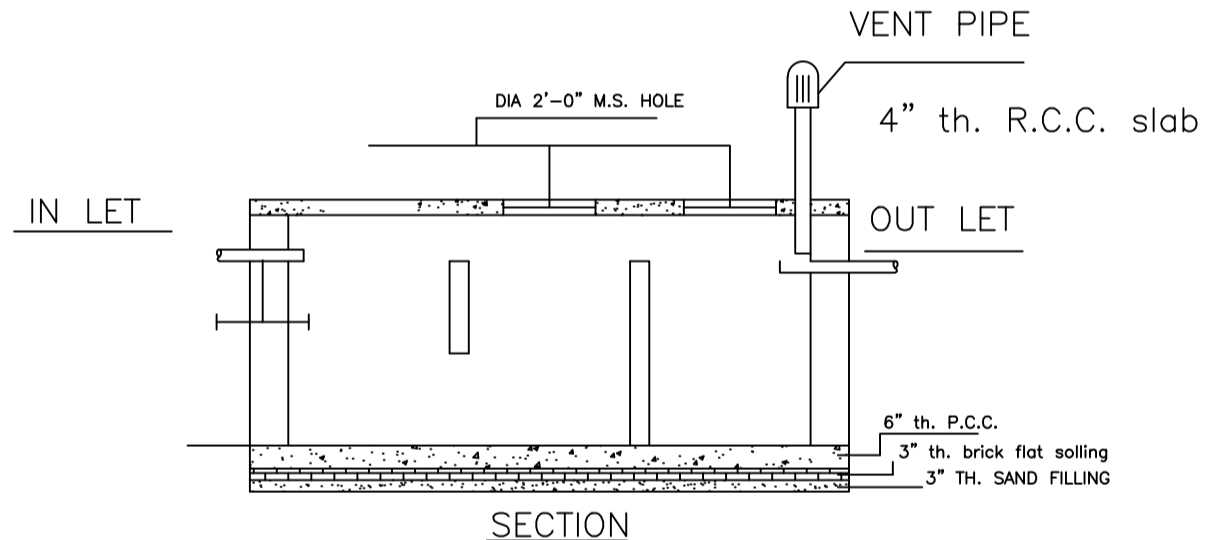

**SECTION**

**DETAILS OF SEPTIC TANK**  
SCALE - 1" = 4'-0"

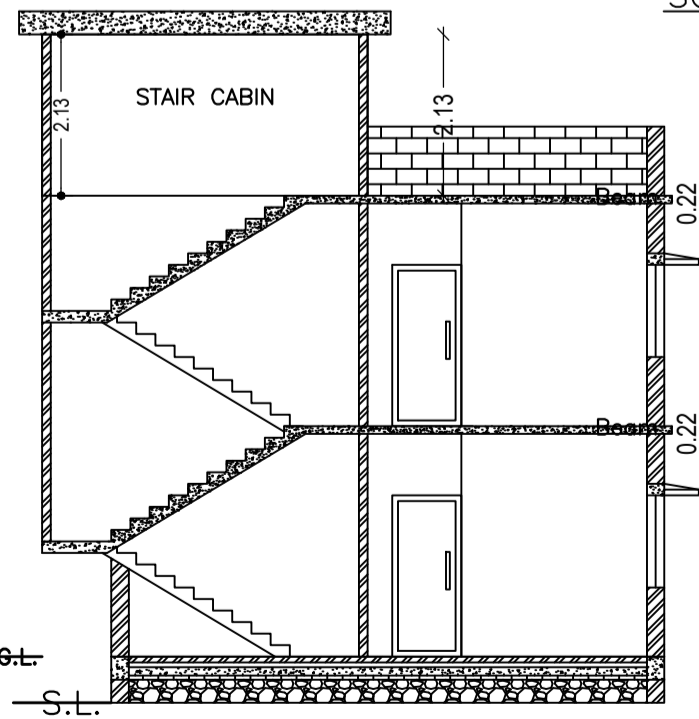

**SECTION - XX'**  
SCALE - 1" = 8'-0"

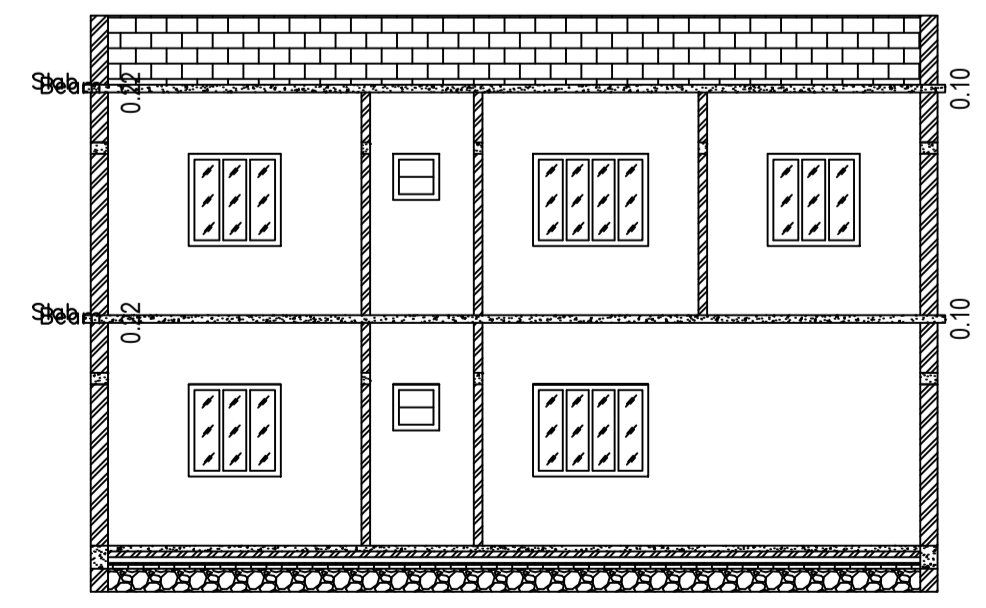

**SECTION - YY'**  
SCALE - 1" = 8'-0"

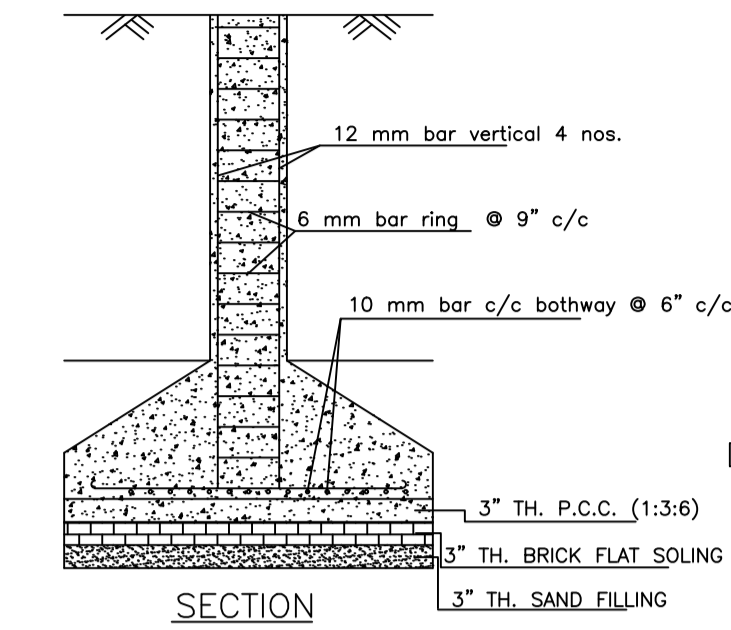

**SECTION**

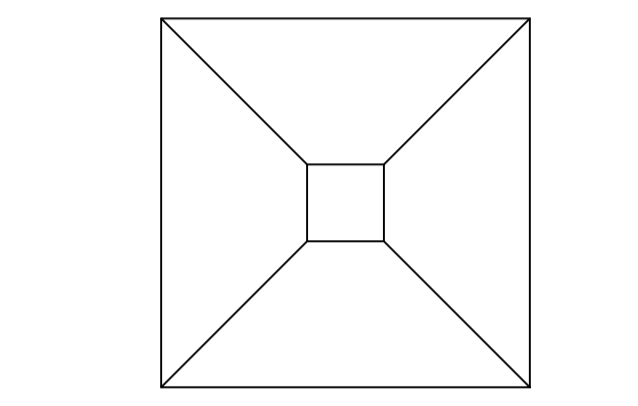

**PLAN**  
DETAILS OF COLUMN FOUNDATION  
SCALE - 1" = 2'-0"

**FAR & Tenement Details (Table 4c-1)**

Building	No. of Same Bldg	Total Built Up Area (Sq.mt.)	Proposed FAR Area (Sq.mt.) Resi.	Total FAR Area (Sq.mt.)	Total Consumed Additional FAR Area (Sq.mt.)	Tnmt (No.)
A (BHARTI)	1	167.64	167.64	167.64	167.64	01
Grand Total:	1	167.64	167.64	167.64	167.64	01

**Proposal Basic Information**

Proposal File No.	MADA/BP/0457/2023
Owner Name	SMT. BHARTI
Khata No	KHATA NO-134
Plot No	PLOT NO-2561
Village Name	Khamarbendi
Use	Residential
SubUse	Bungalow/ Dwelling / Non Apartment

AREA STATEMENT MINERAL AREA DEVELOPMENT AUTHORITY	VERSION NO. : 1.0.68
PROJECT DETAIL:	VERSION DATE: 16/10/2020
Region: JHARKHAND URBAN LOCAL BODIES	Plot Use: Residential
District: DHANBAD	Plot SubUse: Bungalow/ Dwelling / Non Apartment
Authority: MINERAL AREA DEVELOPMENT AUTHORITY	PlotNearbyReligiousStructure: NA
Inward No: MADA/BP/0457/2023	Plot/SubPlot No: PLOT NO-2561
Application Type: General Proposal	North: Plot No. - SAME PLOT
Project Type: Building Permission	South: Plot No. - SAME PLOT
Nature of Development: New	East: Road Width - 6.10
Location of Development Area: Old Area	West: Plot No. - SAME PLOT

AREA DETAILS:		SQ.MT.
AREA OF PLOT (Minimum)	(A)	139.11
NET AREA OF PLOT(Gross Plot Area - Deduction from Gross Plot area)	(A-Deductions)	139.11
Deduction for Balance Plot Area(from Gross Plot Area)		
Common Plot		15.32
Total		15.32
BALANCE AREA OF PLOT(Net Plot Area - Recreational/Amenity space)	(A-Deductions)	123.79
PLOT AREA FOR COVERAGE(Net Plot Area)	(A-Deductions)	139.11
Plot Area for FAR (Net Plot Area + RoadWidening Area)	(A-Deductions)	139.11

COVERAGE CHECK	
Permissible Coverage area ( 70.00 % )	97.38
Proposed Coverage Area ( 60.25 % )	83.82
Total Prop. Coverage Area ( 60.25 % )	83.82
Balance coverage area ( 9.75 % )	13.56

FAR CHECK	
Perm. FAR Area ( 2.500 )	347.77
Total Perm. FAR area	347.77
Residential FAR	167.64
Proposed FAR Area	167.64
Total Proposed FAR Area	167.64
Consumed FAR (Factor)	1.21
Balance FAR Area	180.13

BUILT UP AREA CHECK	
Total Proposed BuiltUp Area	167.64
ARCHITECT (Regd)	RAM PRATAP SINGH
ENGINEER (Regd)	
SUPERVISOR (Regd)	
OWNER (Regd)	SMT. BHARTI
DEVELOPMENT AUTHORITY	LOCAL BODY

COLOR INDEX	
PLOT BOUNDARY	Black
ABUTTING ROAD	Green
PROPOSED CONSTRUCTION	Red
COMMON PLOT	Yellow
ROAD WIDENING AREA	Blue
EXISTING (To be retained)	Blue
EXISTING (To be demolished)	Yellow

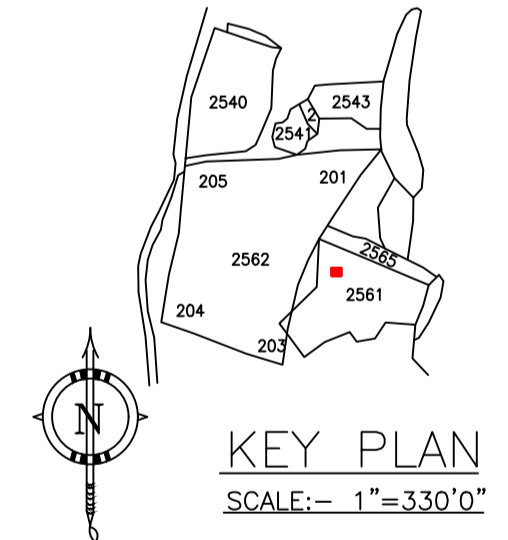

**KEY PLAN**  
SCALE:- 1"=330' 0"

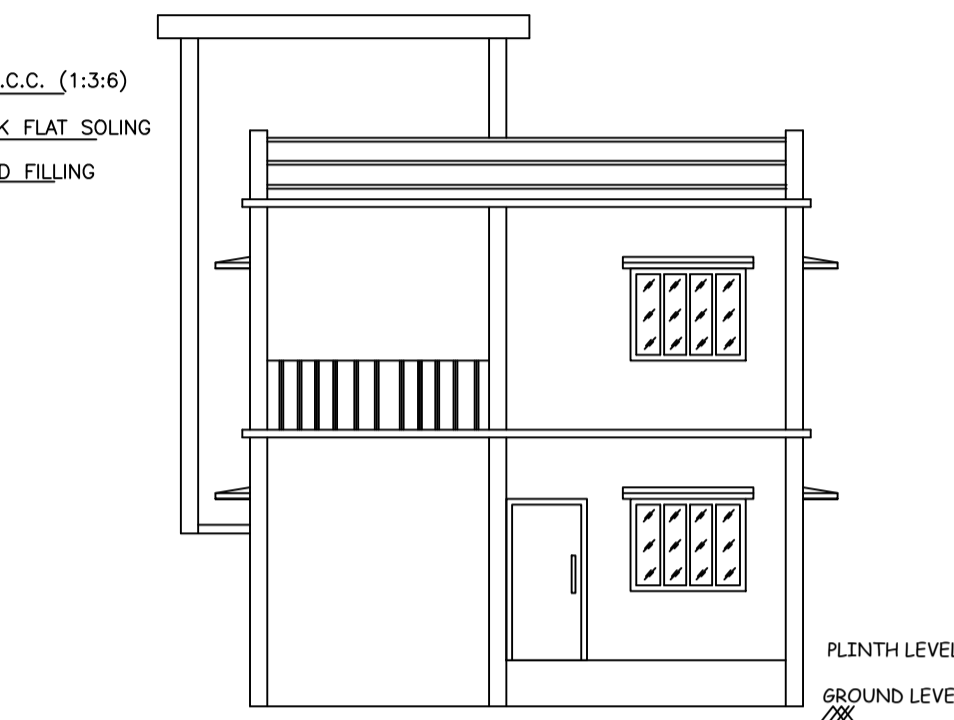

**FRONT ELEVATION**  
SCALE - 1" = 8'-0"

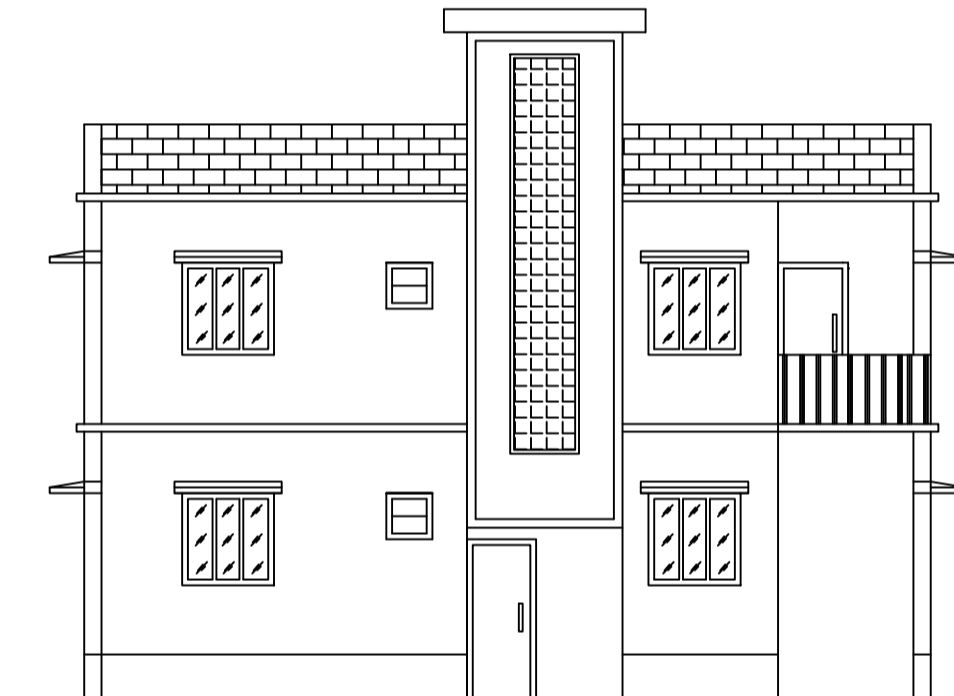

**LEFT SIDE ELEVATION**  
SCALE - 1" = 8'-0"

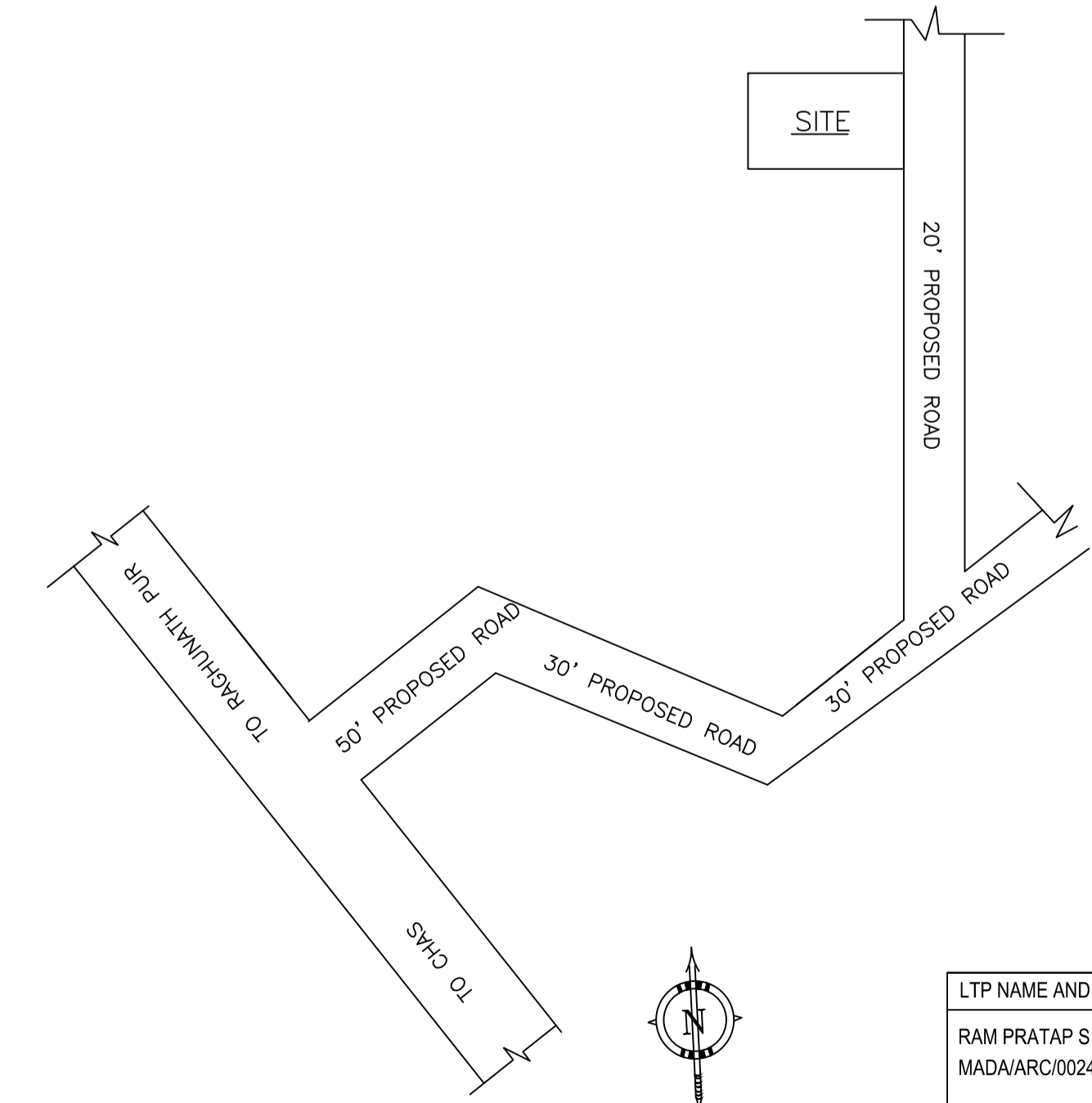

**LOCATION PLAN**  
NOT TO SCALE

**Buildingwise Floor FAR Details**

Floor Name	Building Name A (BHARTI)		Total	
	Proposed Built Up Area (Sq.mt.)	Proposed FAR Area (Sq.mt.)	Total Proposed Built Up Area (Sq.mt.)	Total FAR Area (Sq.mt.)
Ground Floor	83.82	83.82	83.82	83.82
First Floor	83.82	83.82	83.82	83.82
Terrace Floor	0.00	0.00	0.00	0.00
Total :	167.64	167.64	167.64	167.64

**Building USE/SUBUSE Details**

Building Name	Building Use	Building SubUse	Building Structure
A (BHARTI)	Residential	Bungalow/ Dwelling / Non Apartment	Non-Highrise

LTP NAME AND SIGNATURE	STRUCTURAL ENG'S NAME AND SIGNATURE	BUILDER NAME AND SIGNATURE	DIGITAL SIGNATURE
RAM PRATAP SINGH MADA/ARC/0024/2019			

Proposal Basic Information

Proposal File No.	MADA/BP/0457/2023
Owner Name	SMT. BHARTI
Khata No	KHATA NO-134
Plot No	PLOT NO-2561
Village Name	Khamarbendi
Use	Residential
SubUse	Bungalow/ Dwelling / Non Apartment

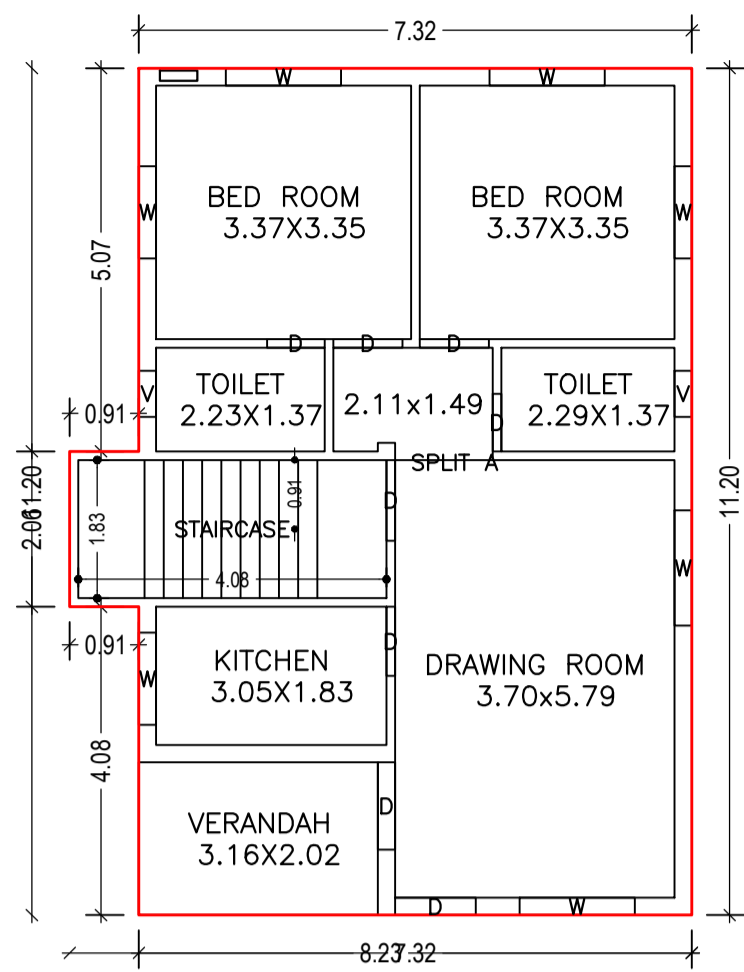

GROUND FLOOR PLAN (Proposed) SCALE 1:100

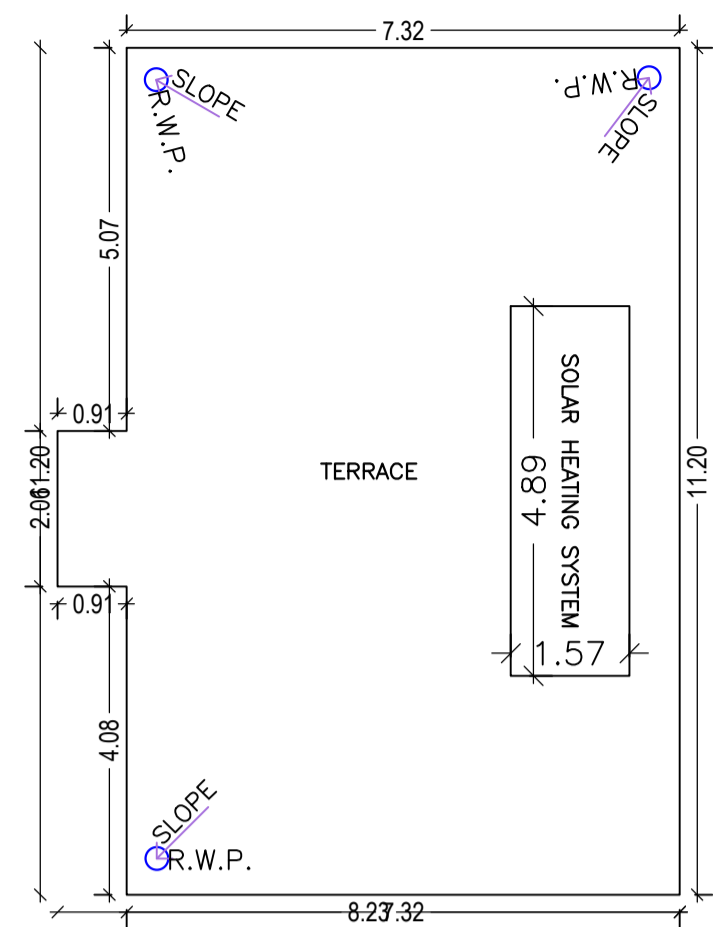

TERRACE FLOOR PLAN (SCALE 1:100)

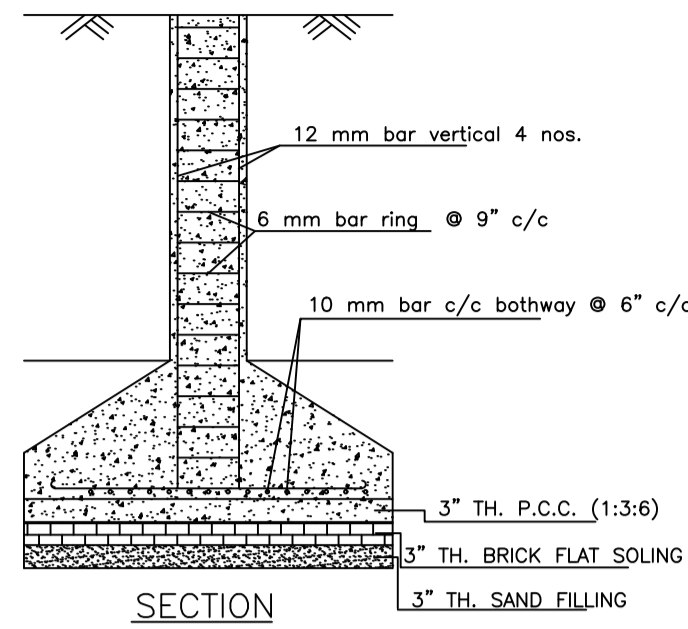

SECTION

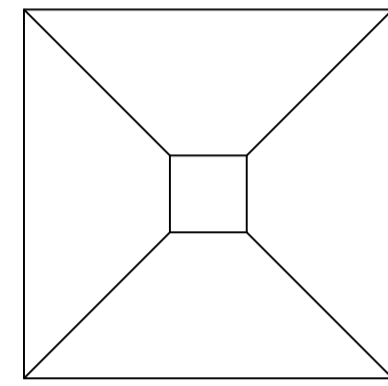

PLAN

DETAILS OF COLUMN FOUNDATION SCALE - 1" = 2'-0"

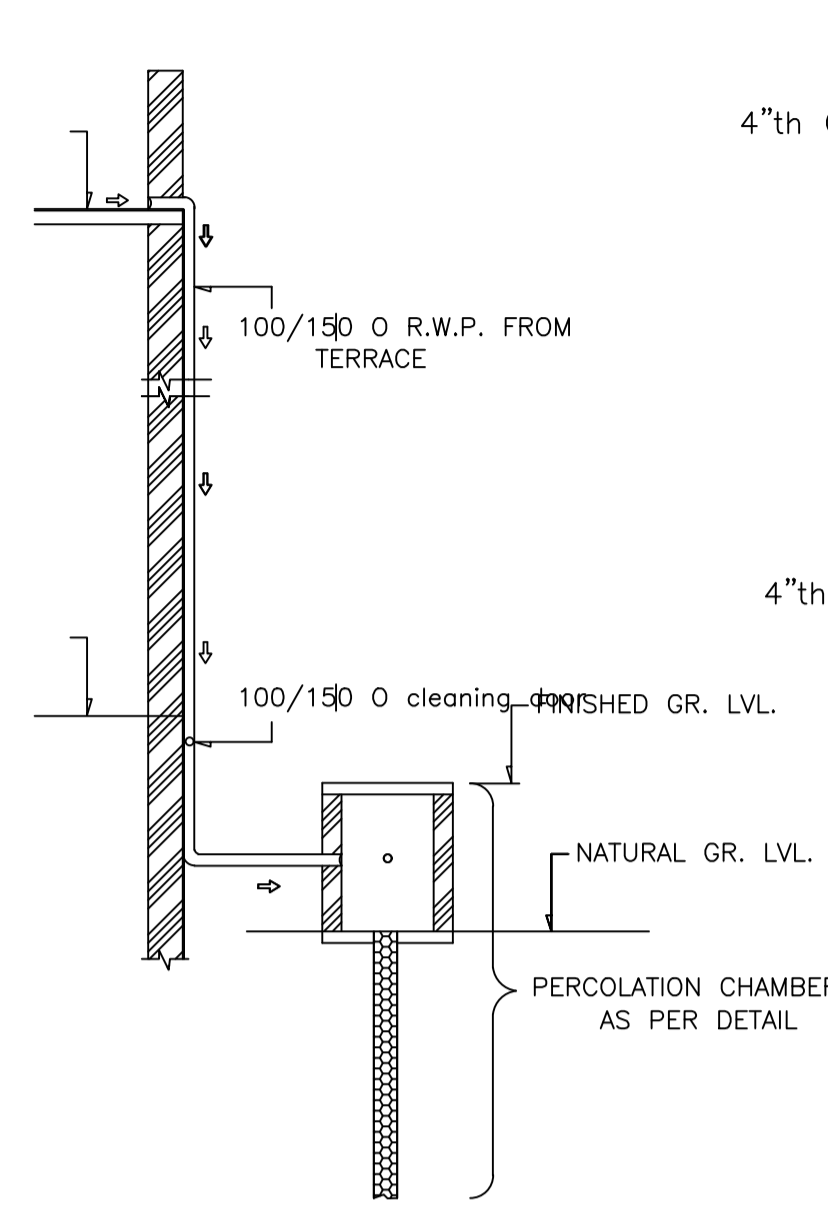

SCALE = 1" = 4'-0"

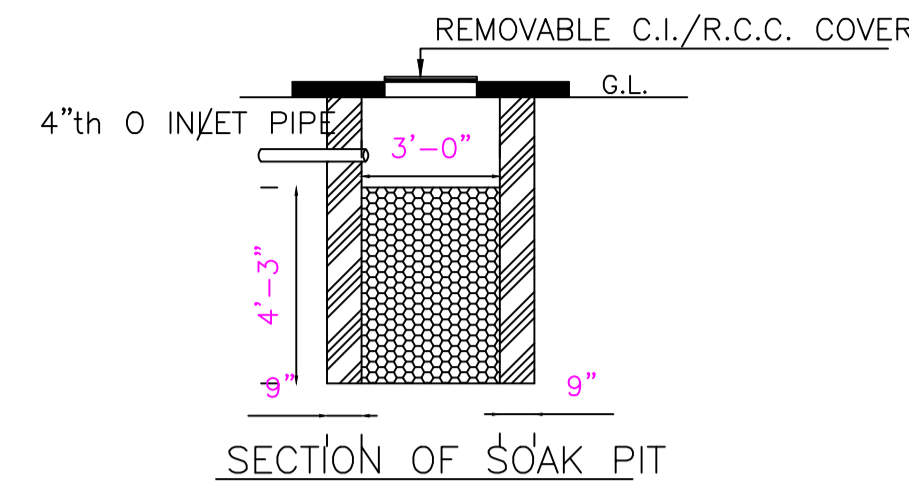

SECTION OF SOAK PIT

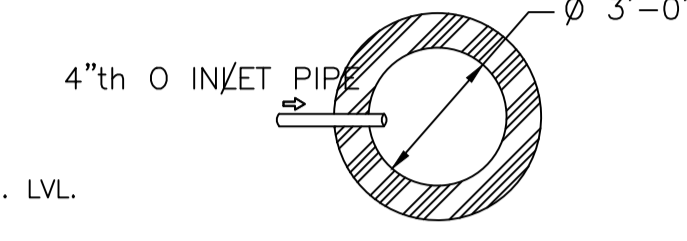

DETAILS OF SOAK PIT SCALE = 1" = 2'-0"

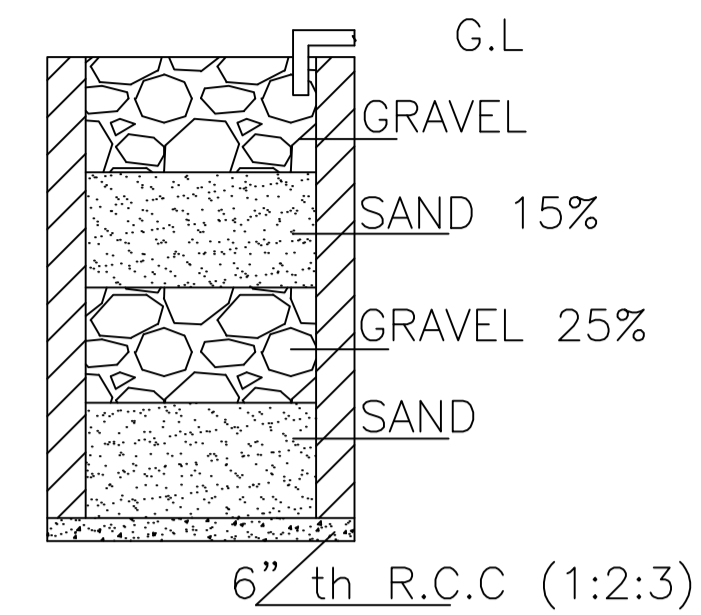

SECTION ON A - B

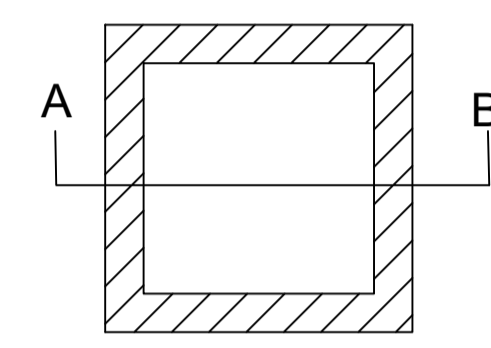

DETAILS DRAWING OF RAIN WATER HARVESTING SCALE:- 1"=2'-0"

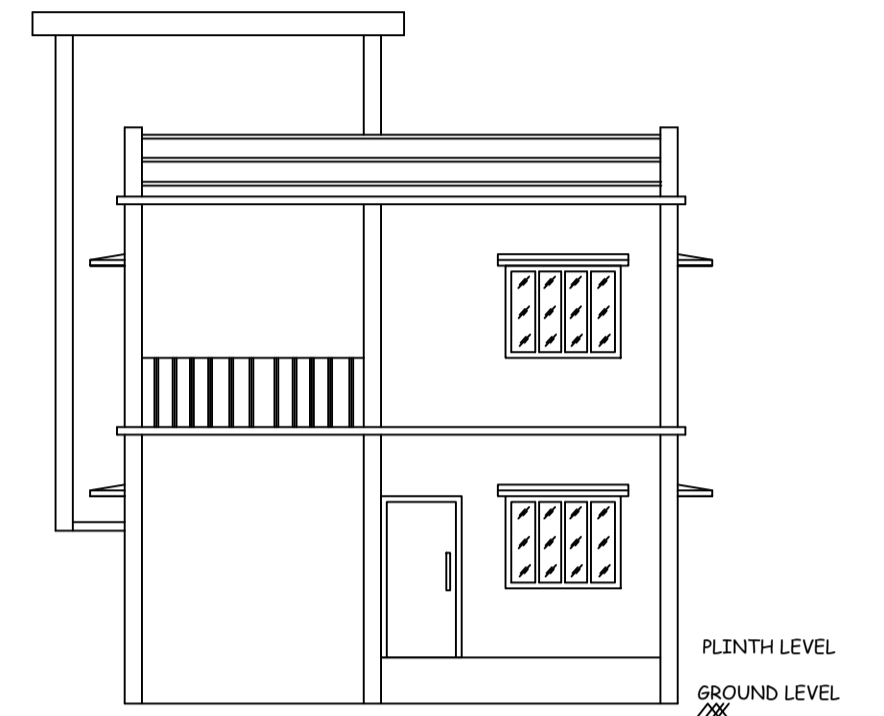

FRONT ELEVATION SCALE - 1" = 8'-0"

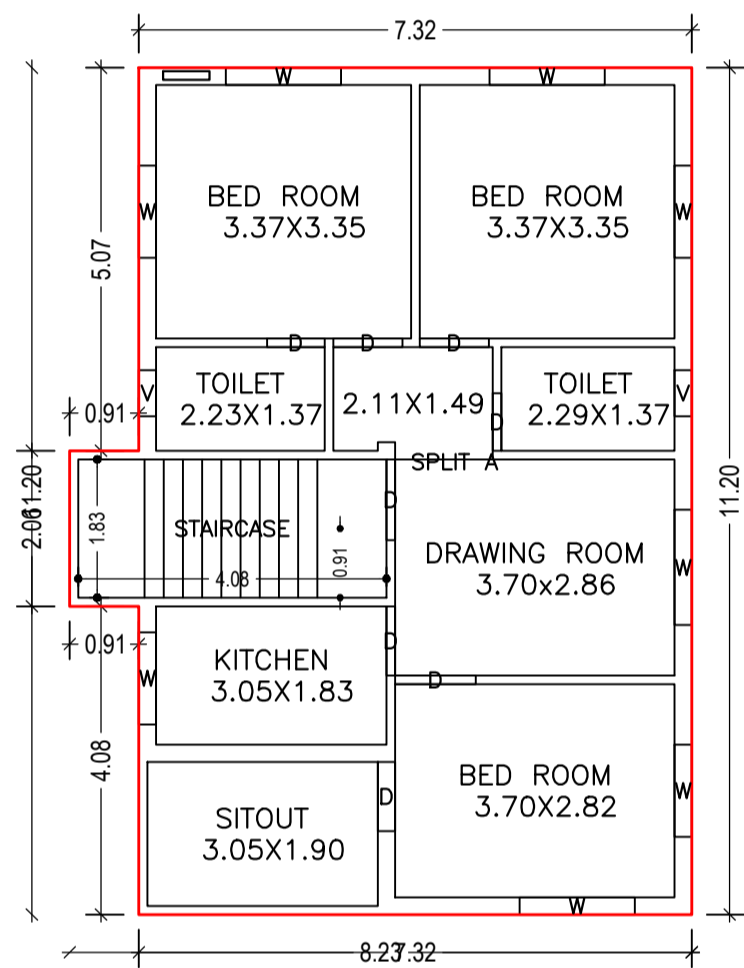

FIRST FLOOR PLAN (Proposed) SCALE 1:100

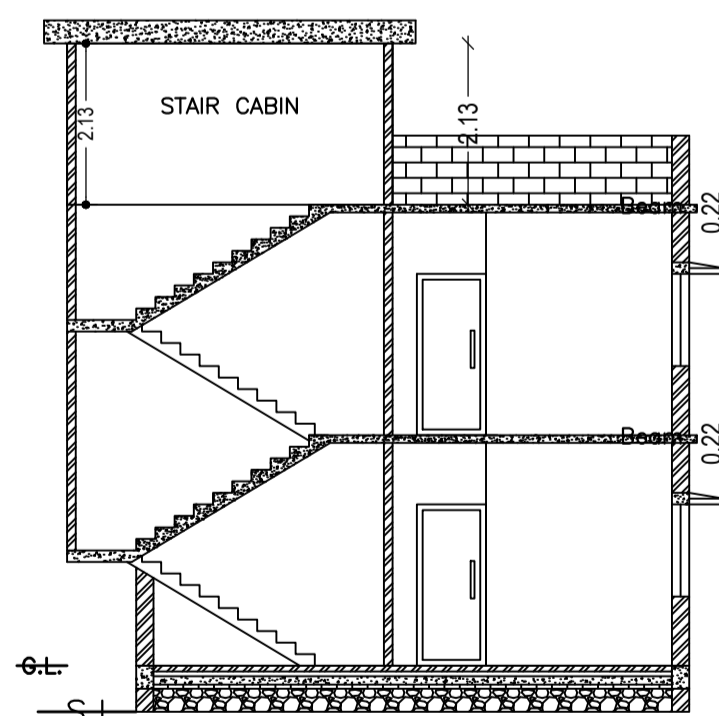

SECTION - XX' SCALE - 1" = 8'-0"

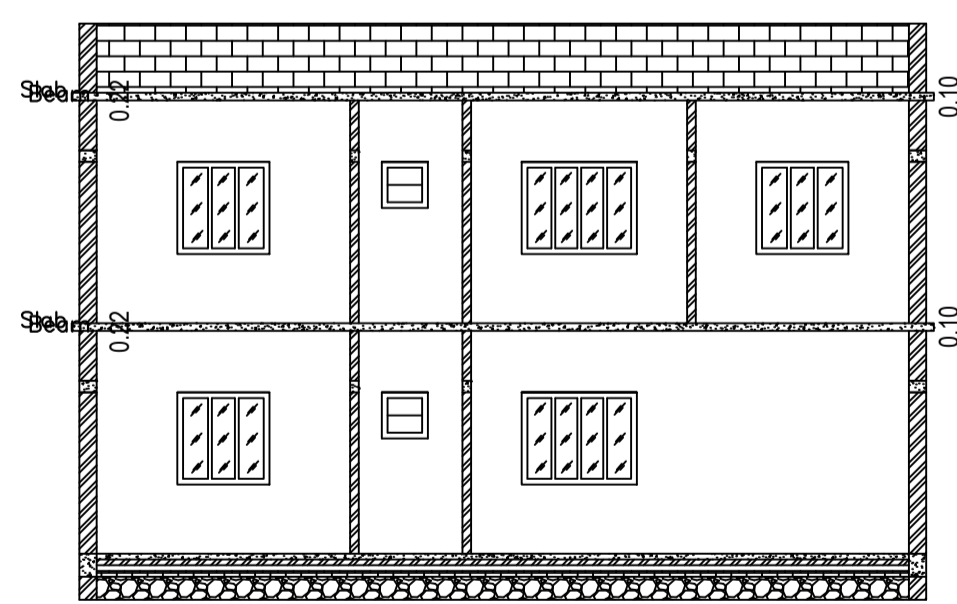

SECTION - YY' SCALE - 1" = 8'-0"

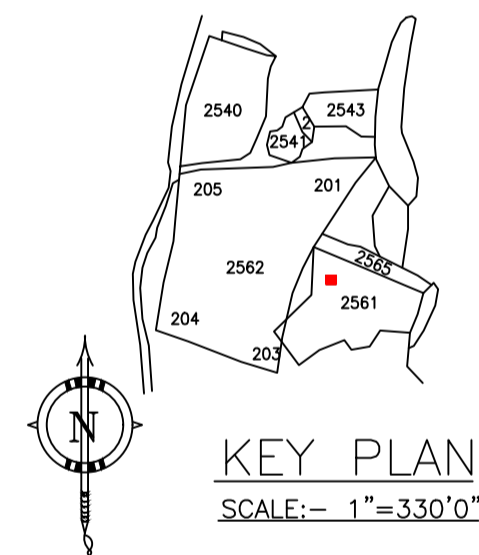

KEY PLAN SCALE:- 1"=330'0"

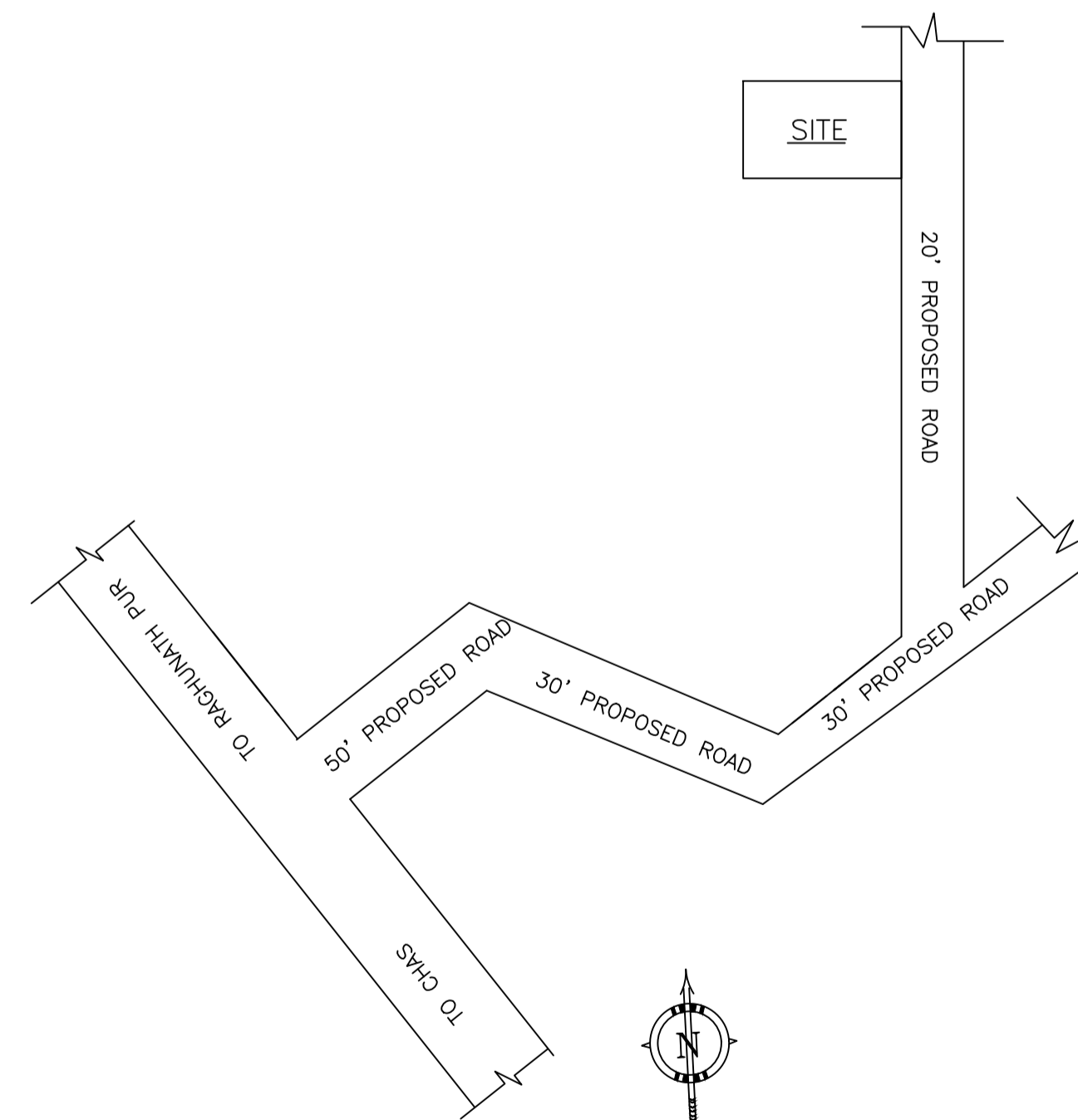

LOCATION PLAN NOT TO SCALE

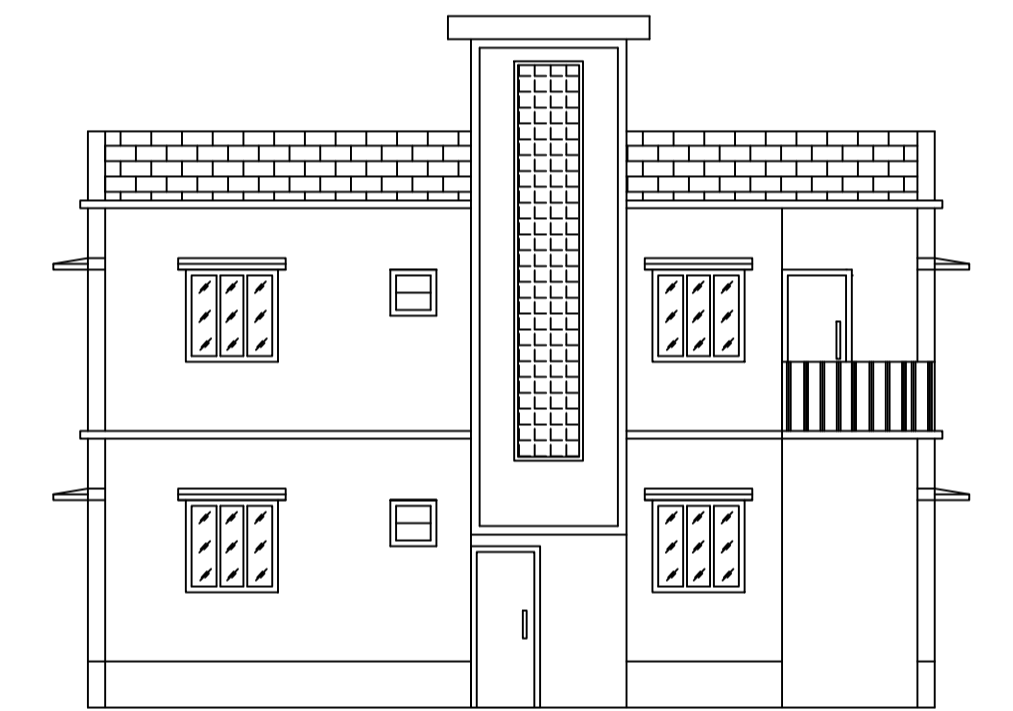

LEFT SIDE ELEVATION SCALE - 1" = 8'-0"

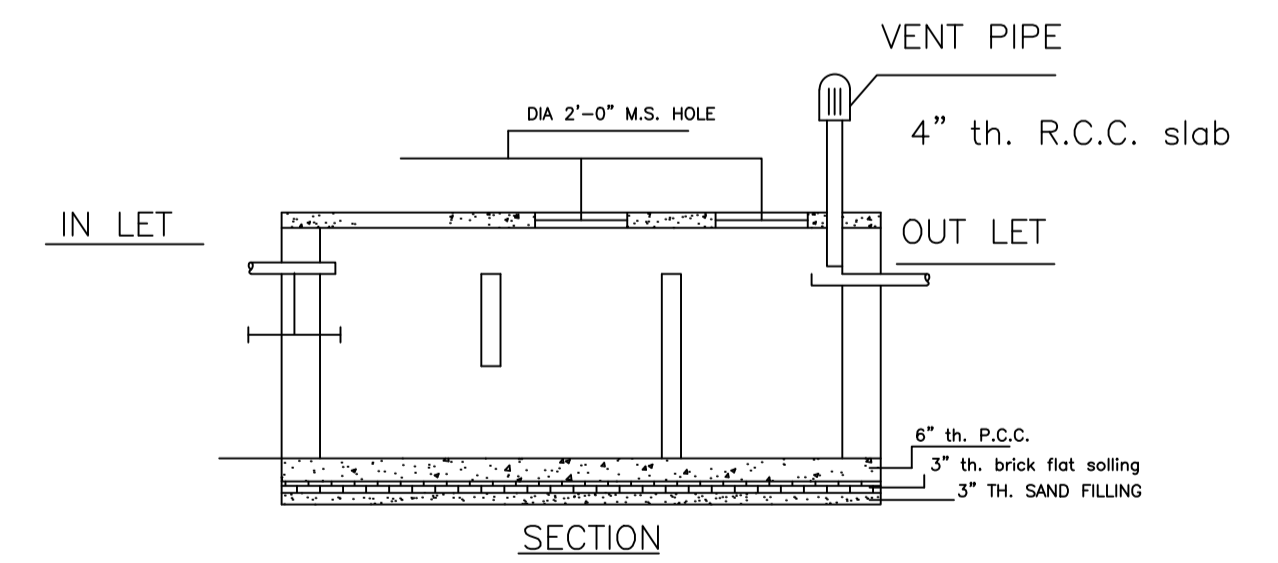

DETAILS OF SEPTIC TANK SCALE - 1" = 4'-0"

Building :A (BHARTI)

Floor Name	Total Built Up Area (Sq.mt.)	Proposed FAR Area (Sq.mt.) Resi.	Total FAR Area (Sq.mt.)	Total Consumed Additional FAR Area (Sq.mt.)	Tnmt (No.)
Ground Floor	83.82	83.82	83.82	83.82	01
First Floor	83.82	83.82	83.82	83.82	00
Terrace Floor	0.00	0.00	0.00	0.00	00
Total:	167.64	167.64	167.64	167.64	01
Total Number of Same Buildings	1				
Total:	167.64	167.64	167.64	167.64	01

SCHEDULE OF DOOR:

BUILDING NAME	NAME	LENGTH	HEIGHT	NOS
A (BHARTI)	D	0.76	2.10	04
A (BHARTI)	D	0.91	2.10	07
A (BHARTI)	D	1.07	2.10	04
A (BHARTI)	D	1.15	2.10	01

SCHEDULE OF WINDOW/VENTILATION:

BUILDING NAME	NAME	LENGTH	HEIGHT	NOS
A (BHARTI)	V	0.61	1.20	04
A (BHARTI)	W	1.22	1.20	07
A (BHARTI)	W	1.52	1.20	08

UnitBUA Table for Building :A (BHARTI)

FLOOR	Name	UnitBUA Type	UnitBUA Area	Carpet Area	No. of Rooms	No. of Tenement
GROUND FLOOR PLAN	SPLIT A	FLAT	167.64	167.51	7	1
FIRST FLOOR PLAN	SPLIT A	FLAT	0.00	0.00	8	0
Total:	-	-	167.64	167.51	15	1

LTP NAME AND SIGNATURE	STRUCTURAL ENG'S NAME AND SIGNATURE	BUILDER NAME AND SIGNATURE	DIGITAL SIGNATURE
RAM PRATAP SINGH MADA/ARC/0024/2019			