

Project Title: SMT MIRA DEVI

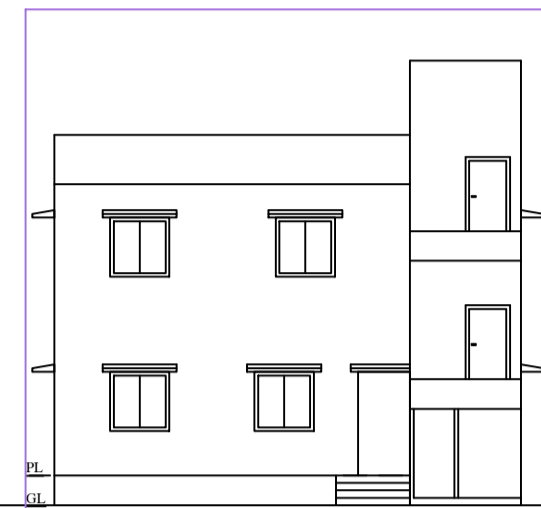

FRONT ELEVATION  
SCALE - 1" = 8'-0"

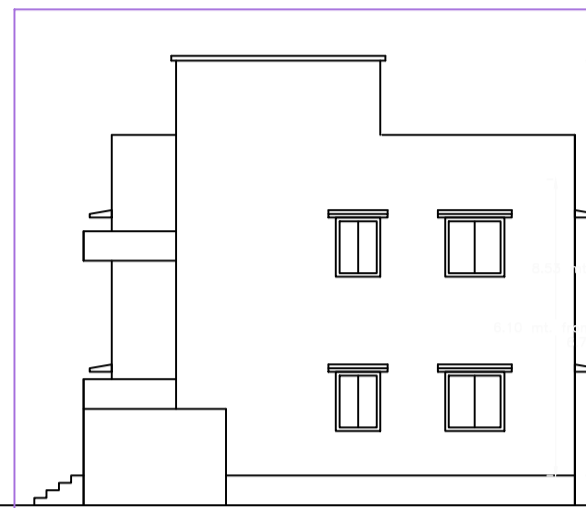

RIGHT SIDE ELEVATION  
SCALE - 1" = 8'-0"

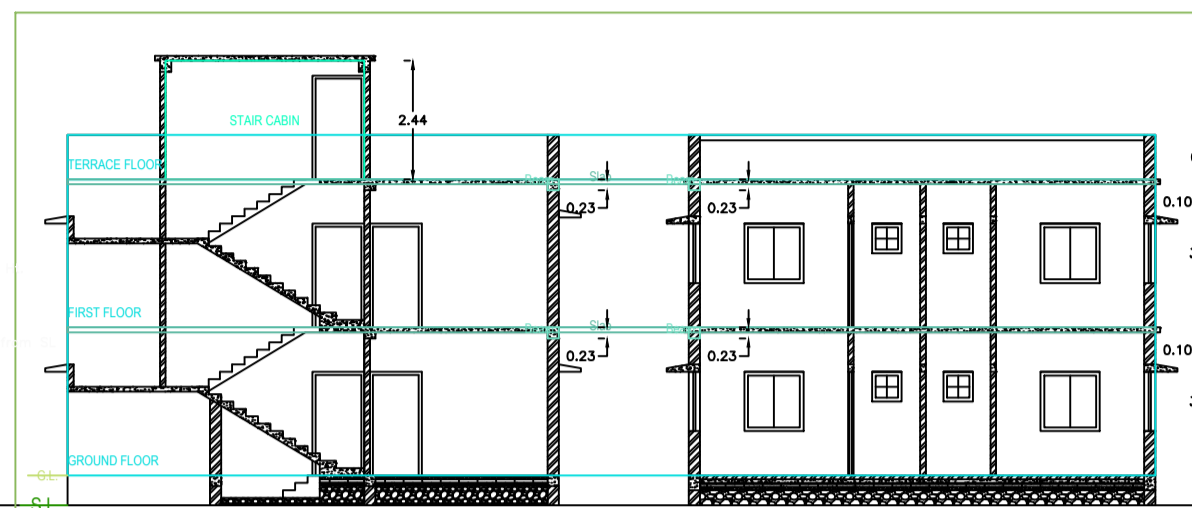

SECTION - XX'  
SCALE - 1" = 8'-0"

SECTION - YY'  
SCALE - 1" = 8'-0"

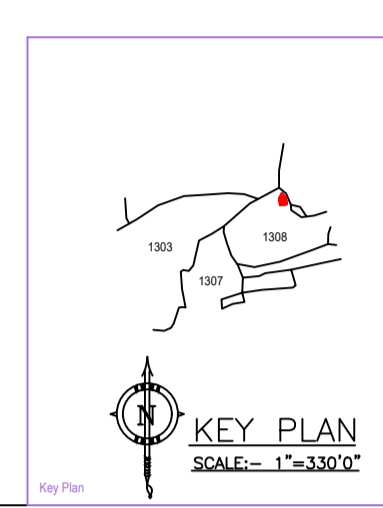

KEY PLAN  
SCALE - 1" = 330'0"

FOR MADA USE

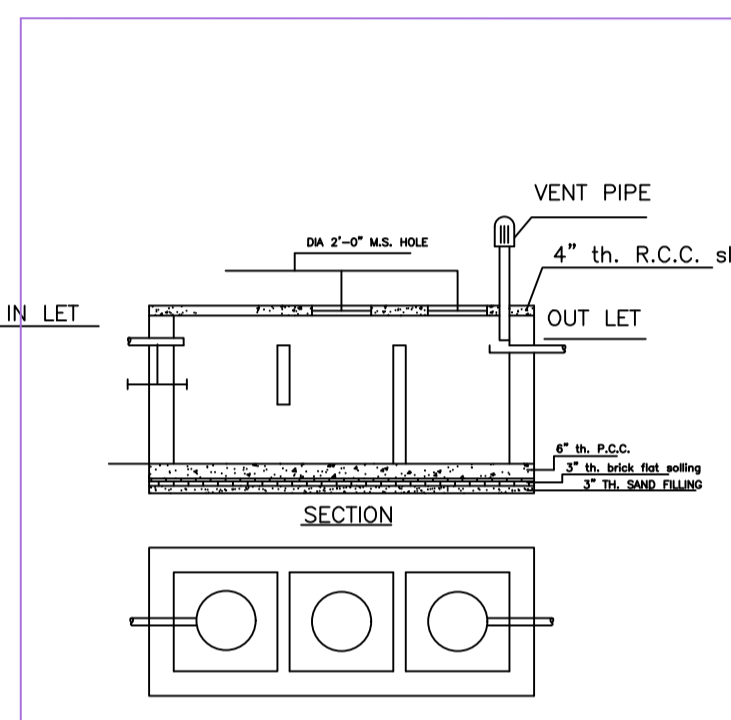

DETAILS OF SEPTIC TANK  
SCALE - 1" = 4'-0"

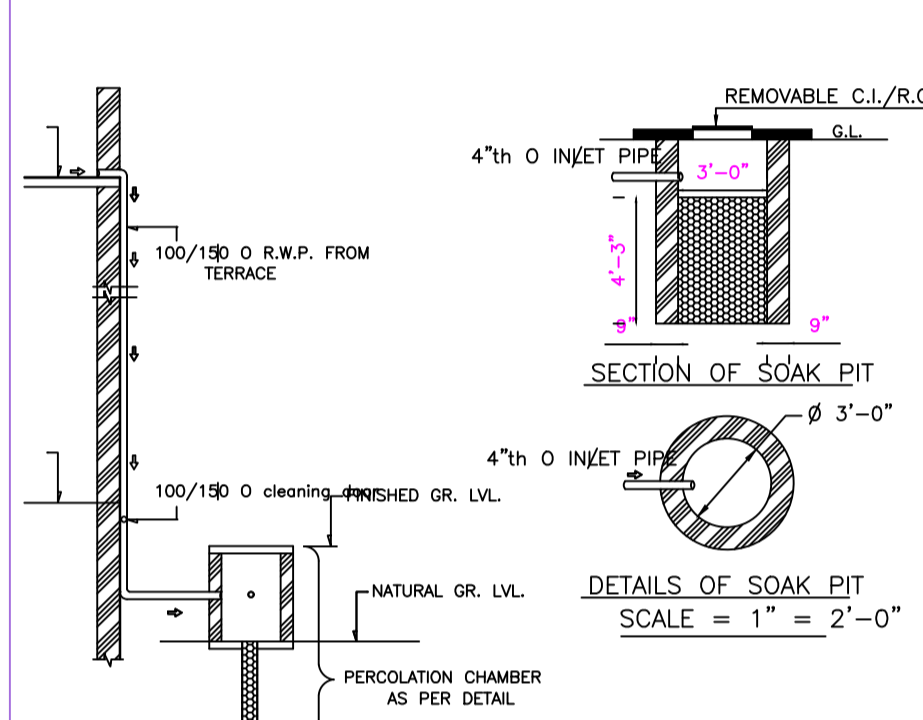

ROOF TOP RAIN WATER COLLECTION SYSTEM  
SCALE = 1" = 4'-0"

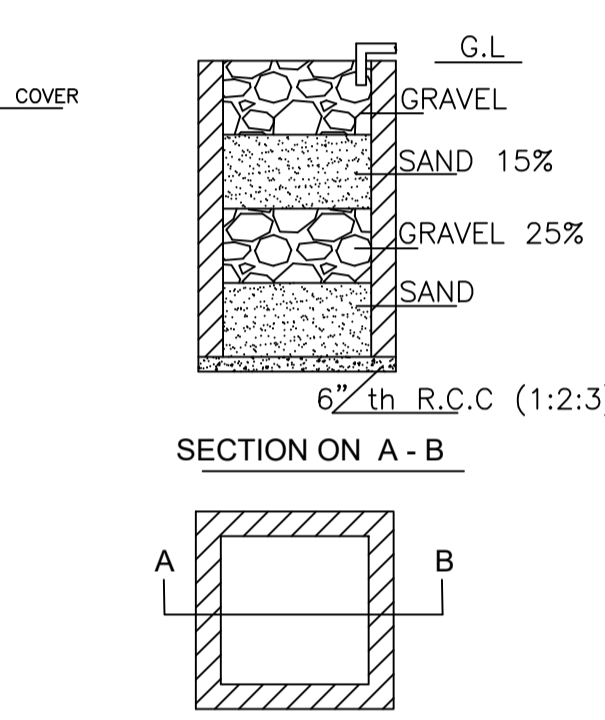

DETAILS DRAWING OF RAIN WATER HARVESTING  
SCALE - 1" = 2'-0"

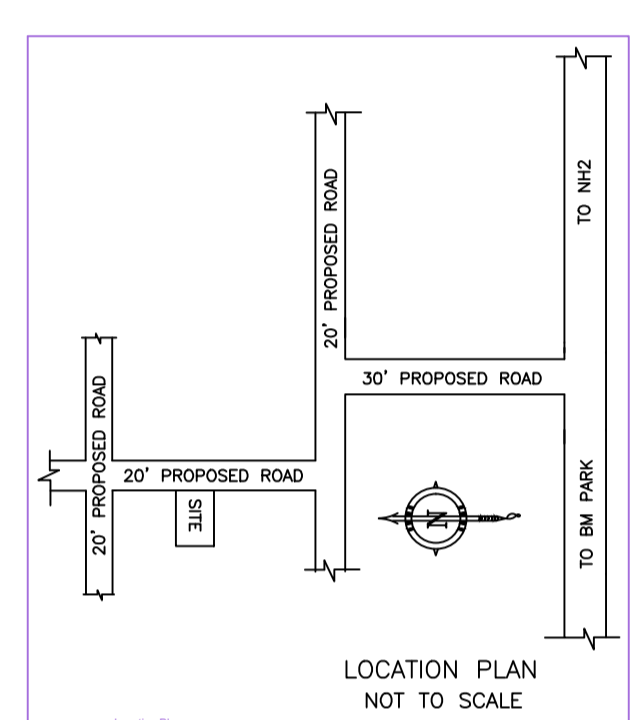

LOCATION PLAN  
NOT TO SCALE

TITLE OF DRAWING

PROPOSED PLAN FOR, SMT MIRA DEVI W/O- SRI AJAY KUMAR, AT PRESENT RESIDING AT, 50 U, BABUDIH NEAR JILA SCHOOL, BISUNPUR, P.S./DIST- DHANBAD, (JHARKHAND) FOR RESIDENTIAL BUILDING AT, OLD KHATA NO- 24, NEW KHATA NO-196, OLD C.S.PLOT NO- 1308, NEW C.S. PLOT NO-1361, AREA:- 3.90 DECIMAL SITUATED AT MAUZA NO: 8Z, MAUZA -KURMIDIH (GOVINDPUR), DISTRICT- DHANBAD (J H A R K H A N D)

BRIEF SPECIFICATION

FOUNDATION-----CEMENT CONCRETE (1:3:6)  
FOOTING-----R.C.C. (1:1:3)  
BRICK WORK IN FOUNDATION & SUPERSTRUCTURE  
FIRST CLASS BRICK WORK IN CEMENT MORTAR (1:6)  
D.P.C.-----1" D.P.C. IN CEMENT CONCRETE (1:2:4)  
COLUMNS-----R.C.C. (1:1:3)  
BEAM-----R.C.C. (1:1:3)  
FLOOR-----1" I.P.S. OVER 3" P.C.C.  
ROOF-----4"THK. R.C.C. ROOF (1:1:3)  
LINTEL-----6"THK. R.C.C. LINTEL (1:1:3)  
STAIRS-----RISE-- 6", TREAD-- 10"  
DOORS-----D-3'3"x7'0", D1-3'0"x7'0", D2-2'6"x7'0"  
WINDOWS-----W-5'0"x4'0", W1-4'0"x4'0", W2-2'6"x4'0"  
VENTS-----V-2'0"x2'0"

SCHEDULE

D- 3'-6" X 7'-0"	W- 4'-0" X 4'-0"
D1-3'-0" X 7'-0"	W1- 3'0" X 4'-0"
D2-2'-9" X 7'-0"	V - 2'-0" X 2'-0"

DETAILS OF AREA

LAND AREA	: 1700.00 Sft.
GROUND FLOOR AREA	: 999.14 Sft.
FIRST FLOOR AREA	: 999.14 Sft.
COVERED AREA	: 1998.28 Sft.
% OF PLINTH AREA	: 58.77%
F.A.R	: 1.17

SIGN. OF OWNER

SIGN. OF ARCHITECT

ARCH. RAM PRATAAP SINGU

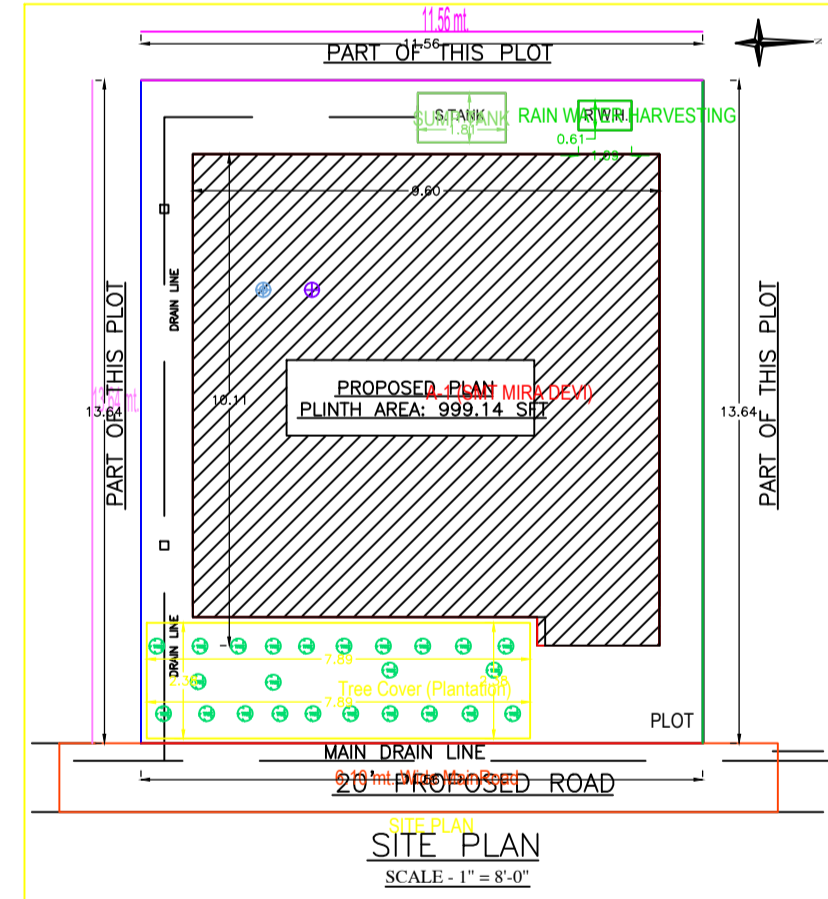

SITE PLAN  
SCALE - 1" = 8'-0"

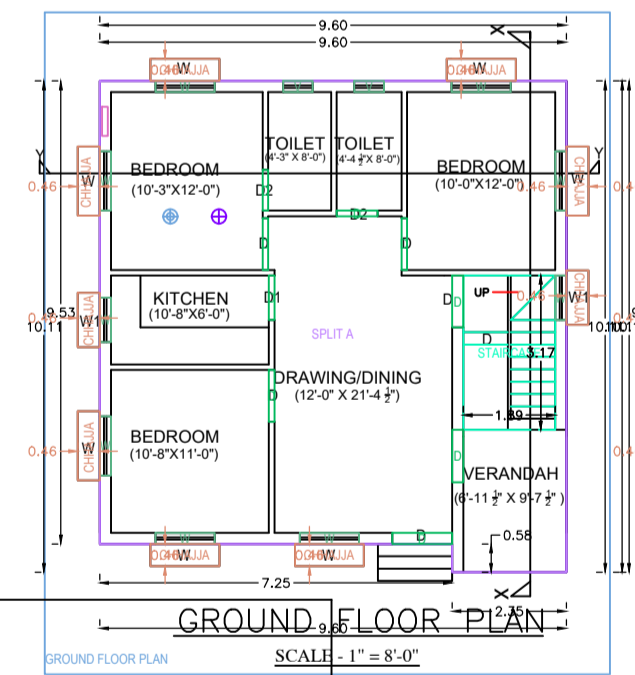

GROUND FLOOR PLAN  
SCALE - 1" = 8'-0"

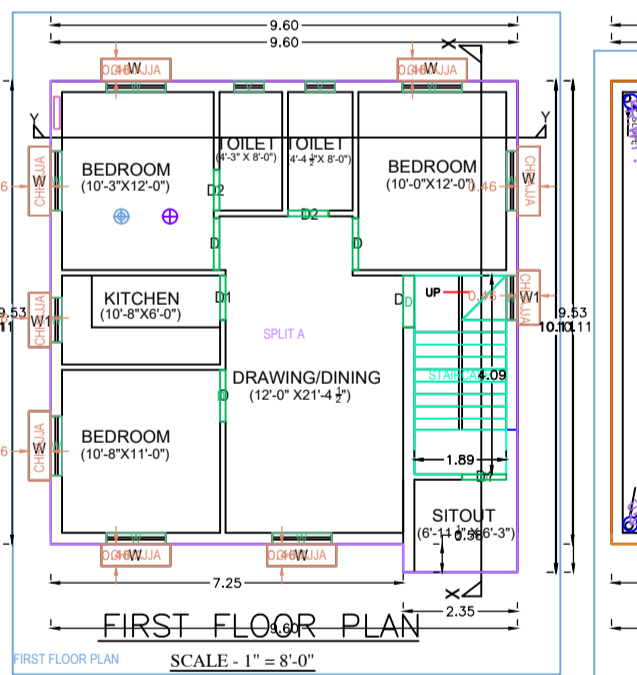

FIRST FLOOR PLAN  
SCALE - 1" = 8'-0"

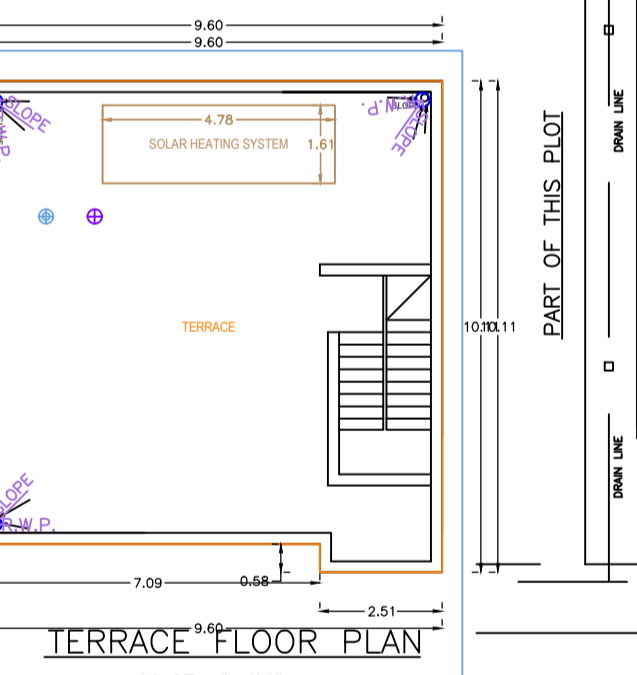

TERRACE FLOOR PLAN  
SCALE - 1" = 8'-0"

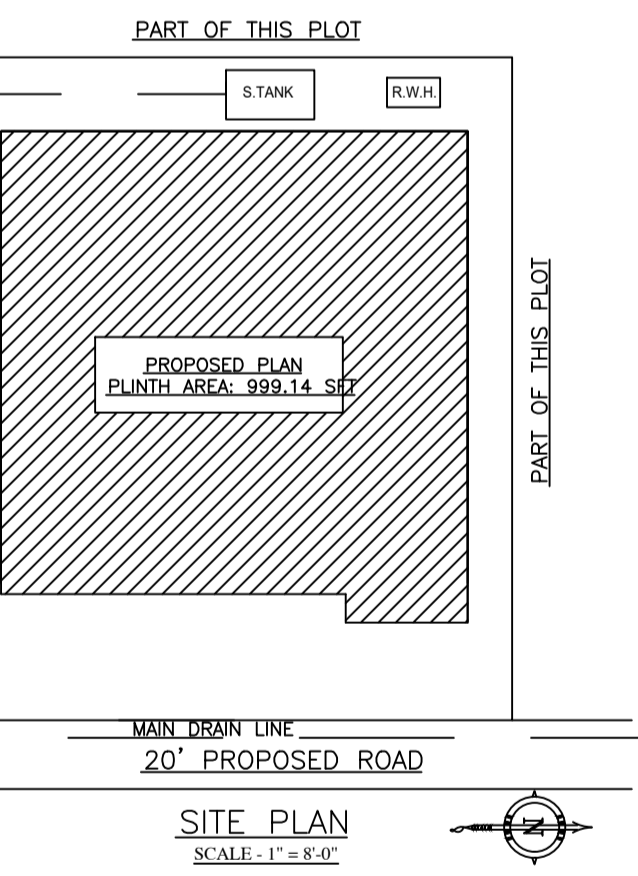

SITE PLAN  
SCALE - 1" = 8'-0"

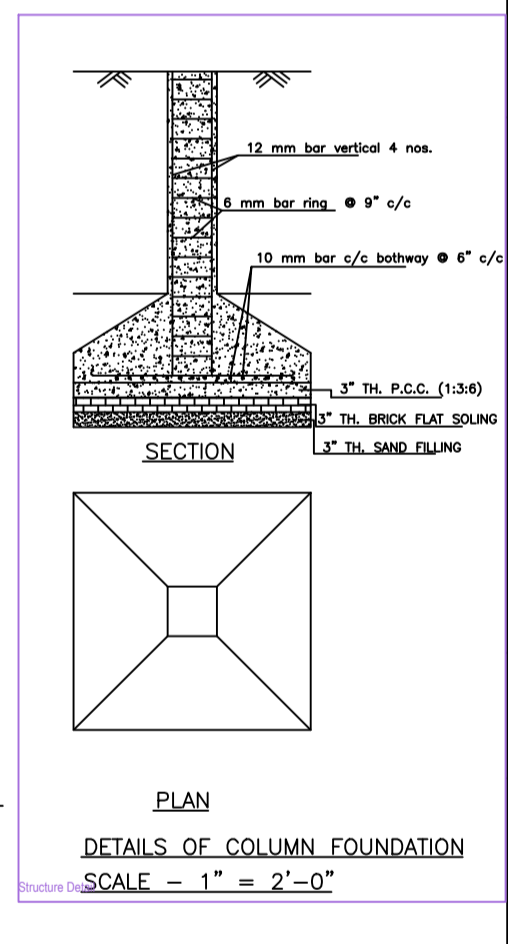

DETAILS OF COLUMN FOUNDATION  
SCALE - 1" = 2'-0"

Building A (SMT MIRA DEVI)

Floor Name	Total Built Up Area (Sq.mt)	Proposed FAR Area (Sq.mt)	Total FAR Area (Sq.mt)	Trmt (No.)
Ground Floor	999.14	999.14	999.14	01
First Floor	999.14	999.14	999.14	01
Terrace Floor	0.00	0.00	0.00	00
Total	1998.28	1998.28	1998.28	01
Total Number of Same Buildings	1	1998.28	1998.28	01
Total	1998.28	1998.28	1998.28	01

SCHEDULE OF JOINERY:

BUILDING NAME	NAME	LENGTH	HEIGHT	NOS
A/SMT MIRA DEVI	D	0.84	2.10	06
A/SMT MIRA DEVI	D	0.51	2.10	03
A/SMT MIRA DEVI	W	1.02	2.10	06
A/SMT MIRA DEVI	D	1.08	2.10	01
A/SMT MIRA DEVI	D	1.23	2.10	01
Total	-	-	-	17

SCHEDULE OF JOINERY:

BUILDING NAME	NAME	LENGTH	HEIGHT	NOS
A/SMT MIRA DEVI	V	0.61	1.00	04
A/SMT MIRA DEVI	W	0.51	1.00	06
A/SMT MIRA DEVI	W	1.22	1.00	14
Total	-	-	-	22

UthBUA Table for Building A (SMT MIRA DEVI)

FLOOR	Name	UthBUA Type	UthBUA Area	Carpet Area	No. of Rooms	No. of Tenement
GROUND FLOOR PLAN	SPLIT A	FLAT	185.65	185.50	8	1
Total	-	-	185.65	185.50	16	1

AREA STATEMENT MINERAL AREA DEVELOPMENT

Authority	Version No.	Version Date
PROJECT DETAIL:	1.0.36	10/10/2020
Project No.	Plot Use - Residential	
District	First Schedule - Municipal/Chowling/Non Apartment	
Block	Land Use Zone - NA	
Application Type	General Proposal	
Project Type	Building Permission	
Nature of Development	Revenue Survey No/Survey No -	
Location	Thana No -	
Sub Location	Post No -	
Village/Mauza Name	Khata No -	
Ward No -	South -	
Road/Street	East -	
	West -	

AREA DETAILS

AREA OF PLOT (Minimum)	(A)	SQ. MT.
Total Plot Area (Gross Plot Area)	(A)	157.71
Deductions from Gross Plot Area	(A)	157.71
Deductions for Balance Plot Area (from Gross Plot Area)	(A)	157.71
COF Area	(A)	18.79
Total	(A)	18.79
Total Plot Area (Net Plot Area)	(A)	138.92
Plot Area for Coverage (Net Plot Area)	(A)	157.71
Plot Area for FSI (Net Plot Area)	(A)	157.71

COVERAGE CHECK

Proposed Coverage Area (Sq. M)	(A)
Total Coverage Area (Sq. M)	92.82
Proposed Area of FAR	185.64
Total Area of FAR	185.64
BUILT UP AREA CHECK:	185.64
Total Proposed Built Up Area	185.64
ARCHT/ENGRG/SUPERVISOR (Regd)	OWNER

DEVELOPMENT AUTHORITY LOCAL BODY

COLOR INDEX

Color	Description
Green	PLINTH BOUNDARY
Red	ARBITRARY ROAD
Blue	PROPOSED WORK (COVERAGE AREA)
Yellow	EXISTING (To be retained)
Black	EXISTING (To be demolished)

MARGIN DETAIL

Building / V/R/O	Road Name	Front Margin	Rear Margin	Side Margin	Sid2 Margin
A/SMT MIRA DEVI	6.10 mt. Wide Main Road	2.01	1.52	1.07	0.89

FAR & Tenement Details (Table 4c-1)

Building	No. of Same Bldg	Total Built Up Area (Sq.mt)	Proposed FAR Area (Sq.mt)	Total FAR Area (Sq.mt)	Trmt (No.)
A/SMT MIRA DEVI	1	185.64	185.64	185.64	01
Grand Total	1	185.64	185.64	185.64	01