

SITE PLAN
SCALE - 1" = 8'-0"

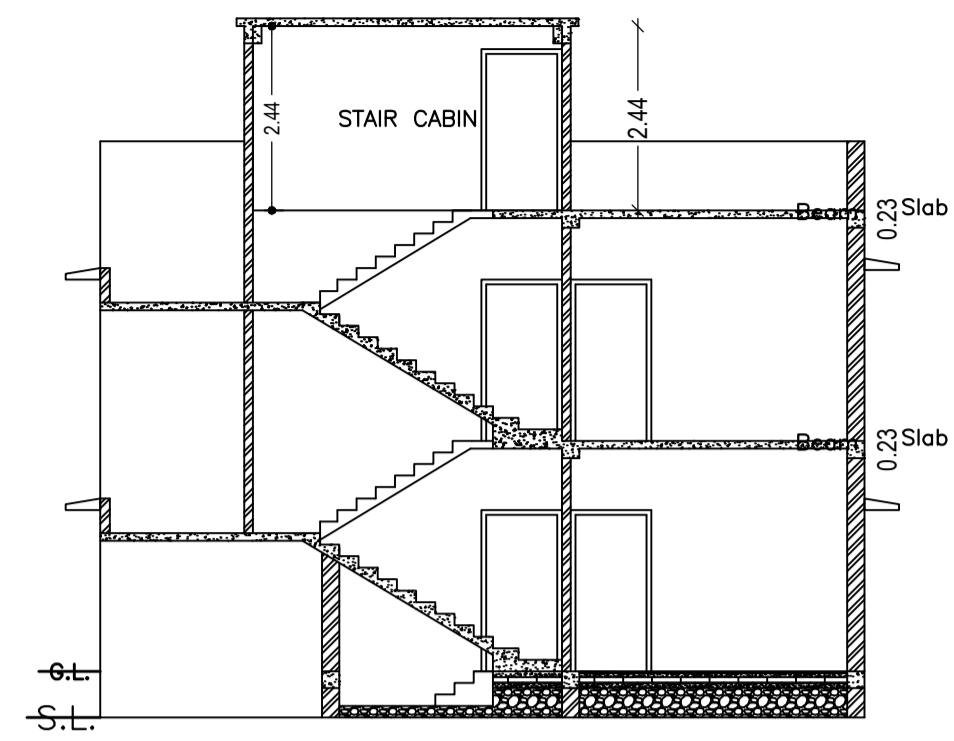

SECTION - XX'
SCALE - 1" = 8'-0"

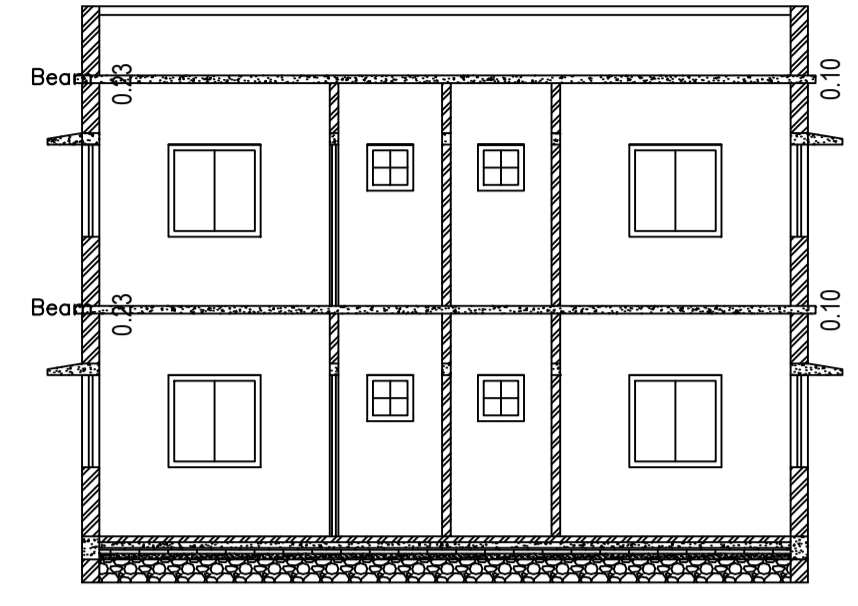

SECTION - YY'
SCALE - 1" = 8'-0"

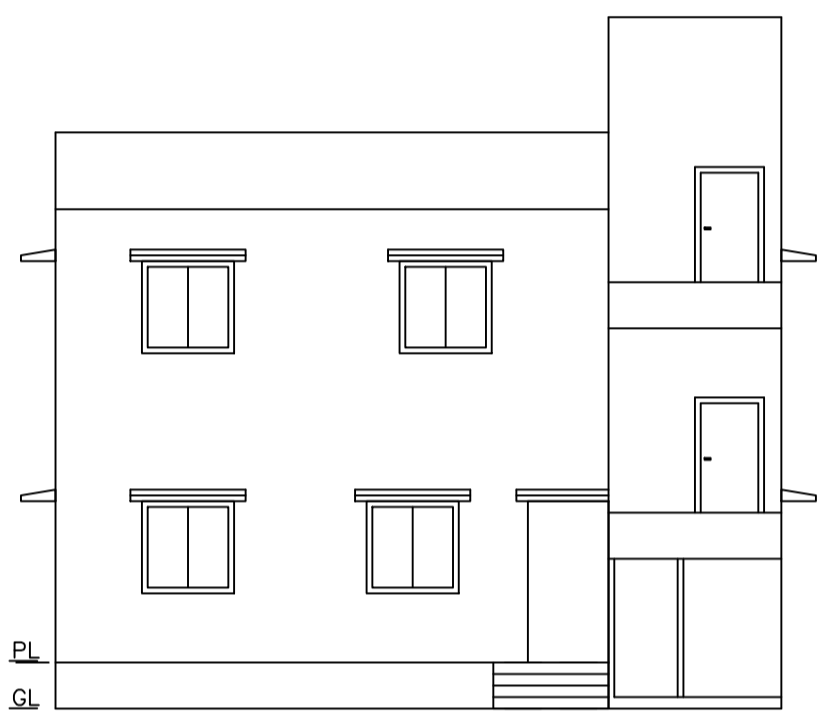

FRONT ELEVATION
SCALE - 1" = 8'-0"

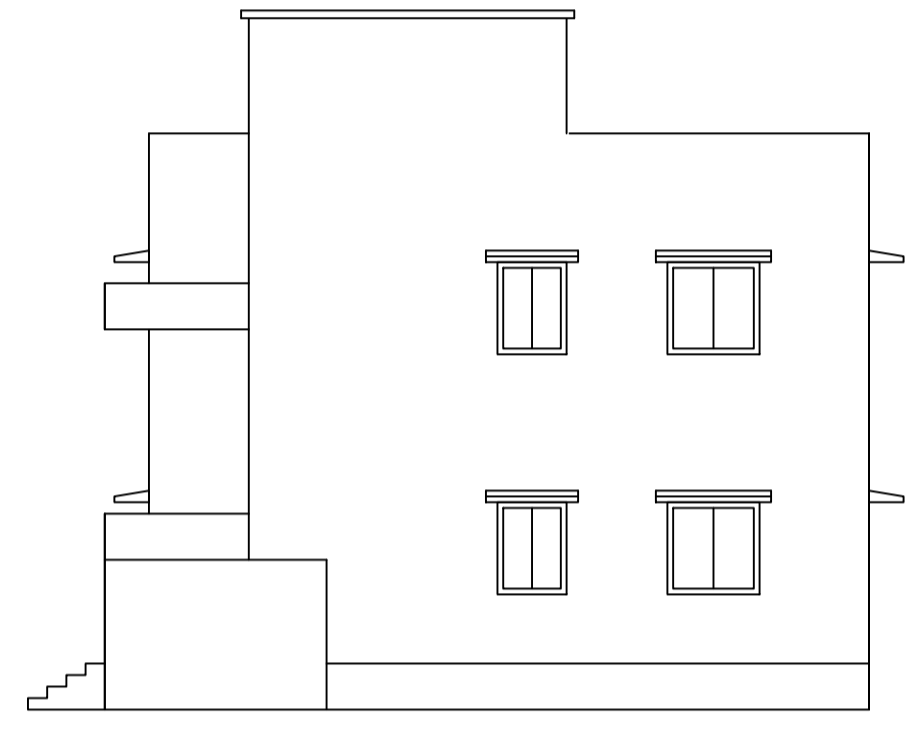

RIGHT SIDE ELEVATION
SCALE - 1" = 8'-0"

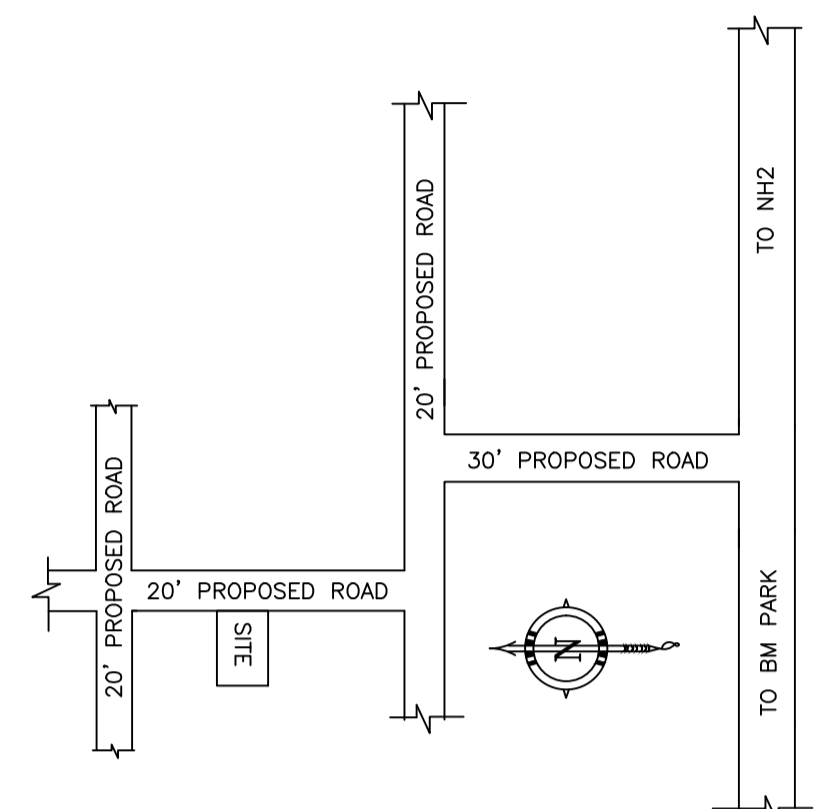

LOCATION PLAN
NOT TO SCALE

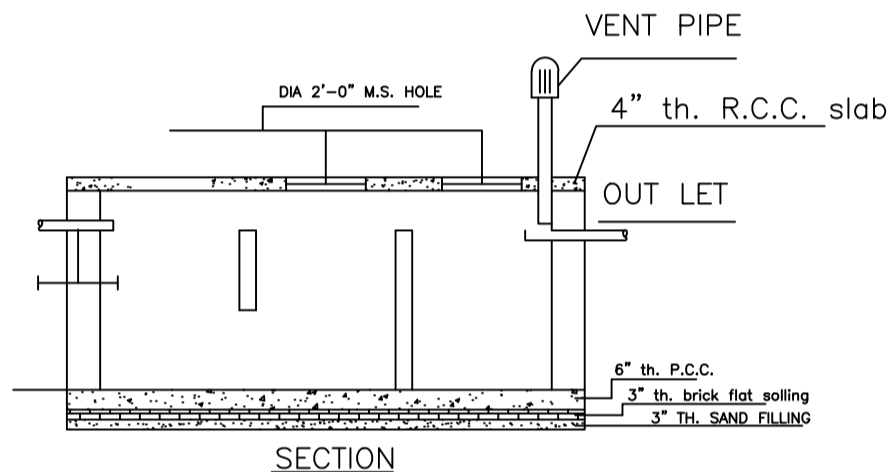

SECTION

DETAILS OF SEPTIC TANK
SCALE - 1" = 4'-0"

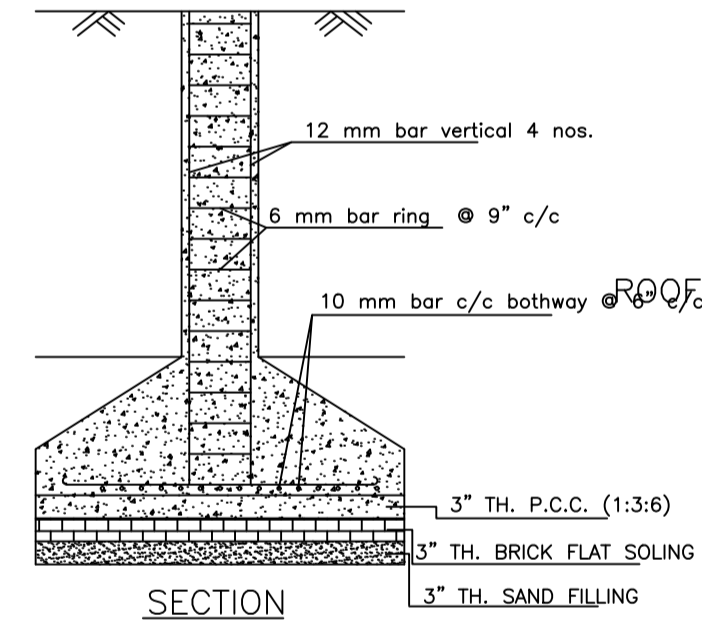

SECTION

ROOF TOP RAIN WATER COLLECTION SYSTEM
SCALE - 1" = 4'-0"

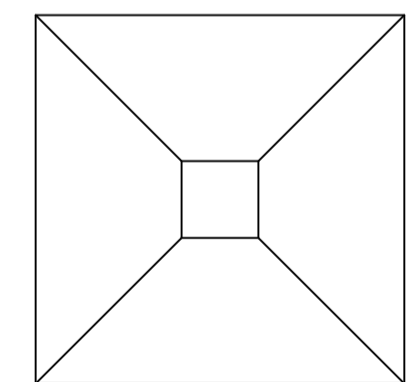

PLAN

DETAILS OF COLUMN FOUNDATION
SCALE - 1" = 2'-0"

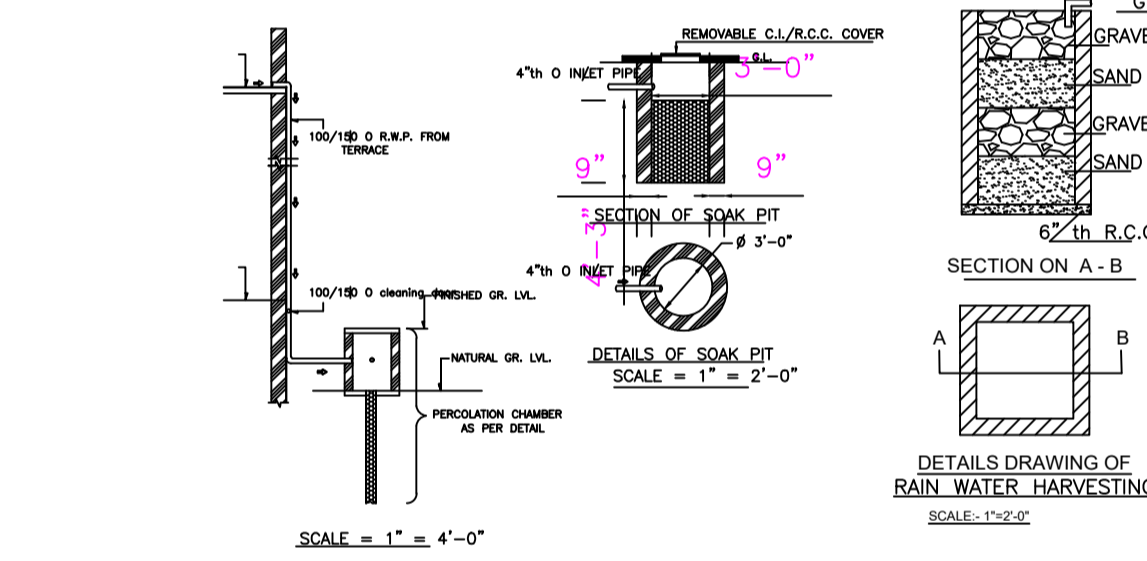

DETAILS OF SOAK PIT
SCALE - 1" = 2'-0"

DETAILS DRAWING OF RAIN WATER HARVESTING
SCALE - 1" = 2'-0"

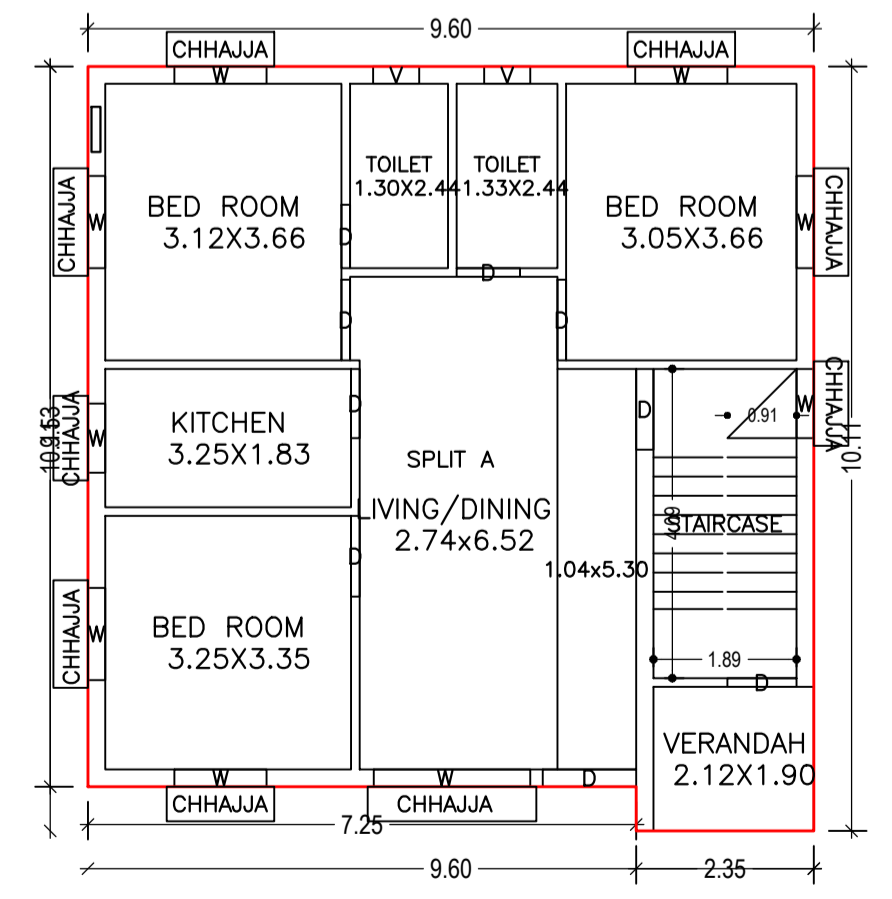

GROUND FLOOR PLAN
(Proposed)
SCALE 1:100

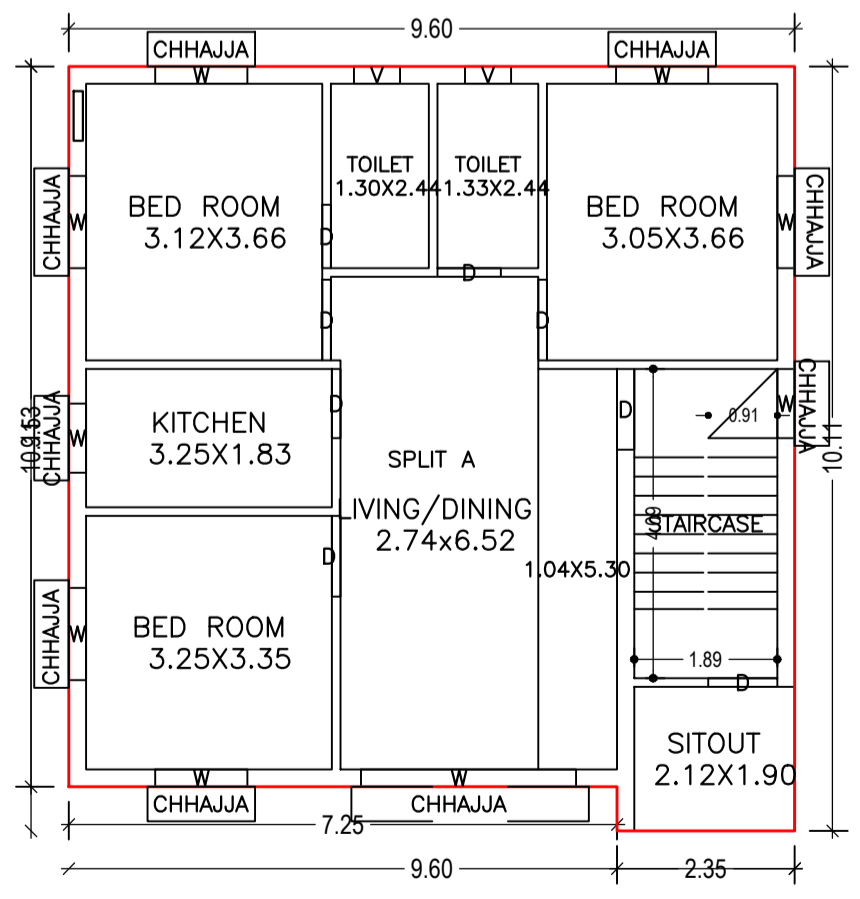

FIRST FLOOR PLAN
(Proposed)
SCALE 1:100

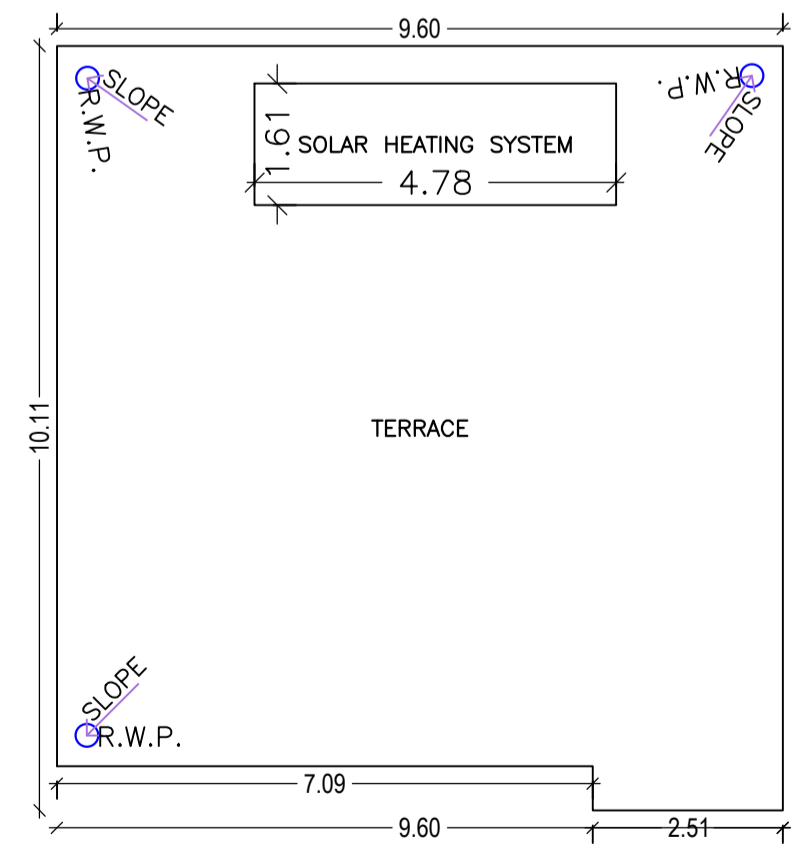

TERRACE FLOOR PLAN
(SCALE 1:100)

Proposal Basic Information	
Proposal File No.	MADA/BP/0379/2023
Owner Name	SMT MIRA DEVI
Khata No	OLD KHATA NO-24, NEW KHATA NO-196
Plot No	OLD PLOT NO-1308, NEW PLOT NO-1361
Village Name	Kurmidi
Use	Residential
SubUse	Bungalow/ Dwelling / Non Apartment

AREA STATEMENT MINERAL AREA DEVELOPMENT		VERSION NO.: 1.0.68
AUTHORITY		VERSION DATE: 16/10/2020
PROJECT DETAIL:		
Region: JHARKHAND URBAN LOCAL BODIES	Plot Use: Residential	
District: DHANBAD	Plot SubUse: Bungalow/ Dwelling / Non Apartment	
Authority: MINERAL AREA DEVELOPMENT AUTHORITY	PlotNearby/ReligiousStructure: NA	
Inward No: MADA/BP/0379/2023	Plot/SubPlot No: OLD PLOT NO-1308, NEW PLOT NO-1361	
Application Type: General Proposal	North: Plot No. - SAME PLOT	
Project Type: Building Permission	South: Plot No. - SAME PLOT	
Nature of Development: New	East: Road Width - 6.10	
Location of Development Area: Old Area	West: Plot No. - SAME PLOT	
AREA DETAILS:		
AREA OF PLOT (Minimum)	(A)	SQ.MT. 157.71
NET AREA OF PLOT(Gross Plot Area - Deduction from Gross Plot area)	(A-Deductions)	157.71
Deduction for Balance Plot Area(from Gross Plot Area)		
Common Plot		18.79
Total		18.79
BALANCE AREA OF PLOT(Net Plot Area - Recreational/Amenity space)	(A-Deductions)	138.92
PLOT AREA FOR COVERAGE(Net Plot Area)	(A-Deductions)	157.71
Plot Area for FAR (Net Plot Area + RoadWidening Area)	(A-Deductions)	157.71
COVERAGE CHECK		
Permissible Coverage area (70.00 %)		110.40
Proposed Coverage Area (58.86 %)		92.82
Total Prop. Coverage Area (58.86 %)		92.82
Balance coverage area (11.15 %)		17.58
FAR CHECK		
Perm. FAR Area (2.500)		394.28
Total Perm. FAR area		394.28
Residential FAR		185.65
Proposed FAR Area		185.65
Total Proposed FAR Area		185.65
Consumed FAR (Factor)		1.18
Balance FAR Area		208.63
BUILT UP AREA CHECK		
Total Proposed BuiltUp Area		185.64
ARCHITECT (Regd)		RAM PRATAP SINGH
ENGINEER (Regd)		
SUPERVISOR (Regd)		
OWNER (Regd)		SMT MIRA DEVI
DEVELOPMENT AUTHORITY		LOCAL BODY

COLOR INDEX	
PLOT BOUNDARY	Black
ABUTTING ROAD	Red
PROPOSED CONSTRUCTION	Green
COMMON PLOT	Yellow
ROAD WIDENING AREA	Blue
EXISTING (To be retained)	Orange
EXISTING (To be demolished)	Purple

Buildingwise Floor FAR Details				
Floor Name	Building Name		Total	
	Proposed Built Up Area (Sq.mt.)	Proposed FAR Area (Sq.mt.)	Total Proposed Built Up Area (Sq.mt.)	Total FAR Area (Sq.mt.)
Ground Floor	92.82	92.82	92.82	92.82
First Floor	92.82	92.82	92.82	92.82
Terrace Floor	0.00	0.00	0.00	0.00
Total :	185.64	185.64	185.64	185.64

Building USE/SUBUSE Details				
Building Name	Building Use	Building SubUse	Building Structure	
A (SMT MIRA DEVI)	Residential	Bungalow/ Dwelling / Non Apartment	Non-Highrise	

FAR & Tenement Details (Table 4c-1)						
Building	No. of Same Bldg	Total Built Up Area (Sq.mt.)	Proposed FAR Area (Sq.mt.) Resi.	Total FAR Area (Sq.mt.)	Total Consumed Additional FAR Area (Sq.mt.)	Tnmt (No.)
A (SMT MIRA DEVI)	1	185.64	185.64	185.64	185.64	01
Grand Total :	1	185.64	185.64	185.64	185.64	01

SCHEDULE OF DOOR:					
BUILDING NAME	NAME	LENGTH	HEIGHT	NOS	
A (SMT MIRA DEVI)	D	0.84	2.10	04	
A (SMT MIRA DEVI)	D	0.91	2.10	04	
A (SMT MIRA DEVI)	D	1.07	2.10	08	
A (SMT MIRA DEVI)	D	1.23	2.10	01	

SCHEDULE OF WINDOW/VENTILATION:					
BUILDING NAME	NAME	LENGTH	HEIGHT	NOS	
A (SMT MIRA DEVI)	V	0.61	1.20	04	
A (SMT MIRA DEVI)	W	0.91	1.20	04	
A (SMT MIRA DEVI)	W	1.22	1.20	12	
A (SMT MIRA DEVI)	W	2.07	1.20	01	
A (SMT MIRA DEVI)	W	2.84	1.20	01	

Building : A (SMT MIRA DEVI)						
Floor Name	Total Built Up Area (Sq.mt.)	Proposed FAR Area (Sq.mt.) Resi.	Total FAR Area (Sq.mt.)	Total Consumed Additional FAR Area (Sq.mt.)	Tnmt (No.)	
Ground Floor	92.82	92.82	92.82	92.82	01	
First Floor	92.82	92.82	92.82	92.82	00	
Terrace Floor	0.00	0.00	0.00	0.00	00	
Total :	185.64	185.64	185.64	185.64	01	
Total Number of Same Buildings	1					
Total :	185.64	185.64	185.64	185.64	01	

UnitBUA Table for Building :A (SMT MIRA DEVI)						
FLOOR	Name	UnitBUA Type	UnitBUA Area	Carpet Area	No. of Rooms	No. of Tenement
GROUND FLOOR PLAN	SPLIT A	FLAT	185.65	185.50	8	1
FIRST FLOOR PLAN	SPLIT A	FLAT	0.00	0.00	8	0
Total:	-	-	185.65	185.50	16	1

LTP NAME AND SIGNATURE	STRUCTURAL ENG'S NAME AND SIGNATURE	BUILDER NAME AND SIGNATURE	DIGITAL SIGNATURE
RAM PRATAP SINGH MADA/ARC/0024/2019			