

Project Title :SHANA ANSARI

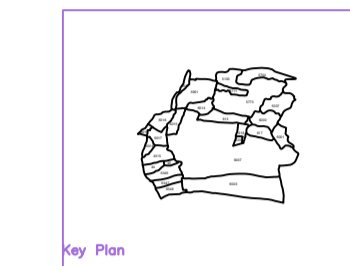
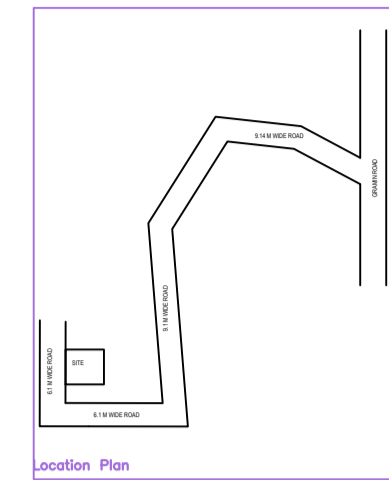
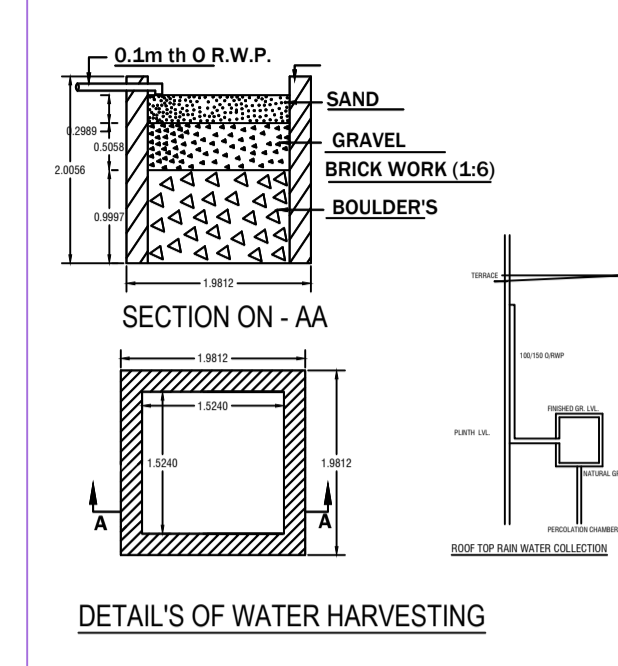
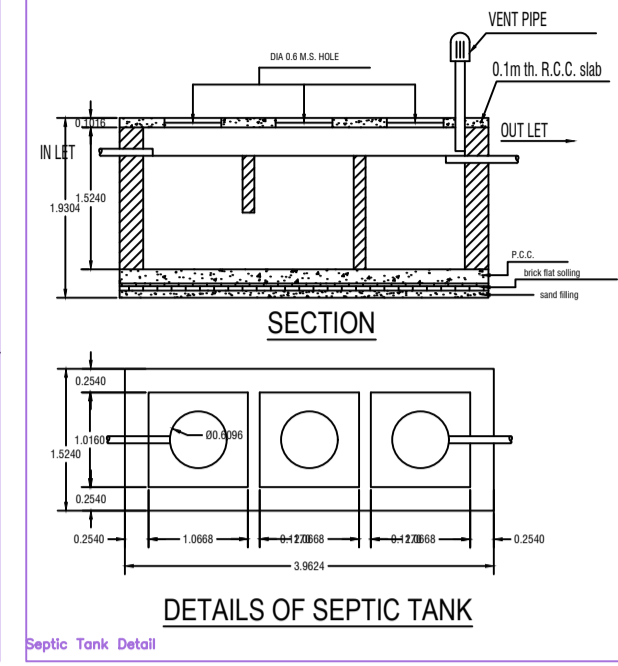
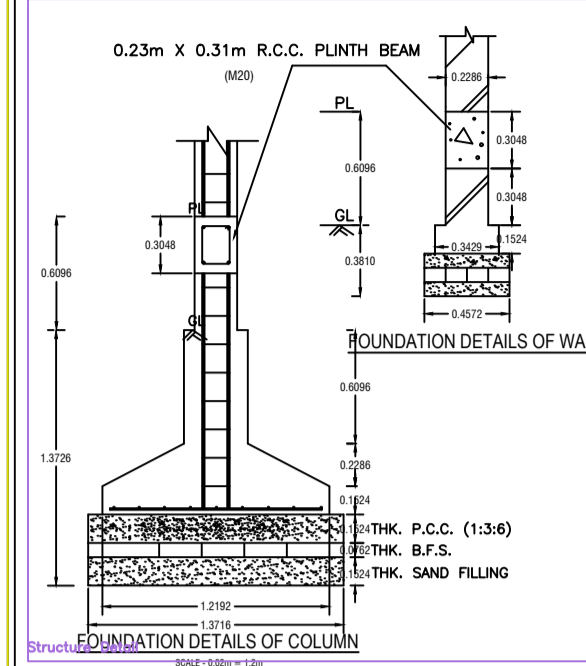

BRIEF SPECIFICATION

FOUNDATION - R.C.C. (1:1.5:3) Column footing foundation.
PLINTH - 12"th R.C.C. (1:1.5:3) all round on plinth level.
FLOORING - 1.5"th Marble flooring over 3"th P.C.C. (1:3:6).
SUPER STRUCTURE - First class brick work in cement mortar (1:6).
SLAB,BEAM, stairs & LINTEL - All R.C.C. work (1:1.5:3).
WOOD WORK - All door & window frames of sal wood
PLASTERING - 12mm cement plaster (1:6) both side.

SCHEDULE

D1 - 1.07 X 2.13	W - 0.9 x 1.22
D2 - 0.9 X 2.13	W1 - 1.22 x 1.22
D3 - 0.76 x 2.13	W2 - 1.5 x 1.22
CG - 1.22 x 2.13	V - 0.61 x 0.61

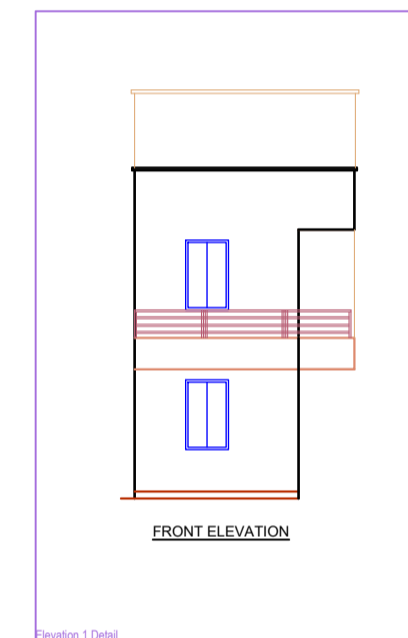
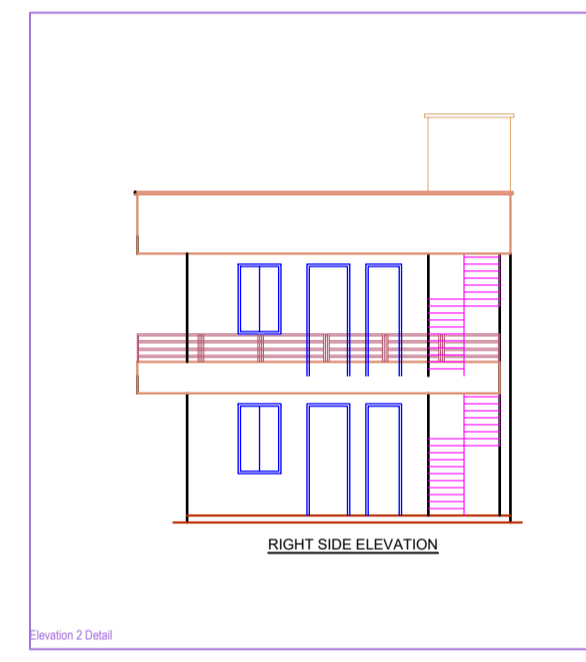
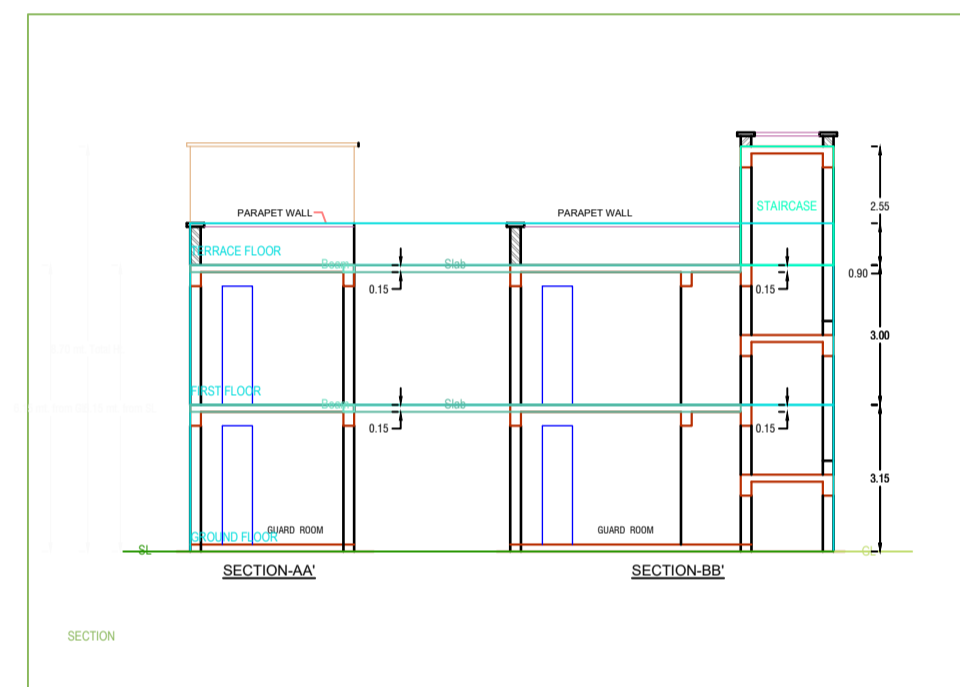

SIG. OF OWNER

SIG. OF ENGINEER

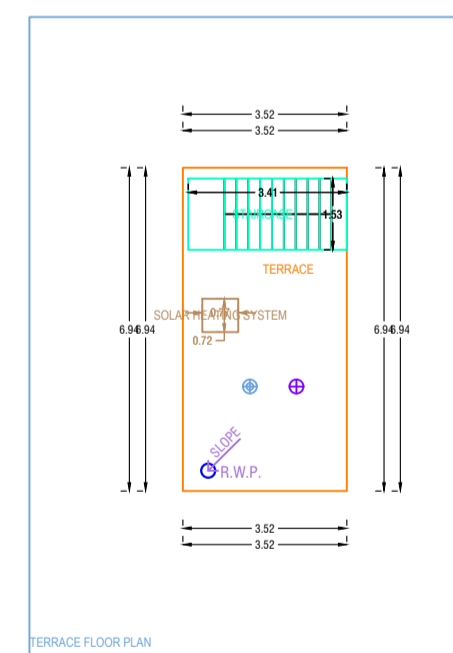
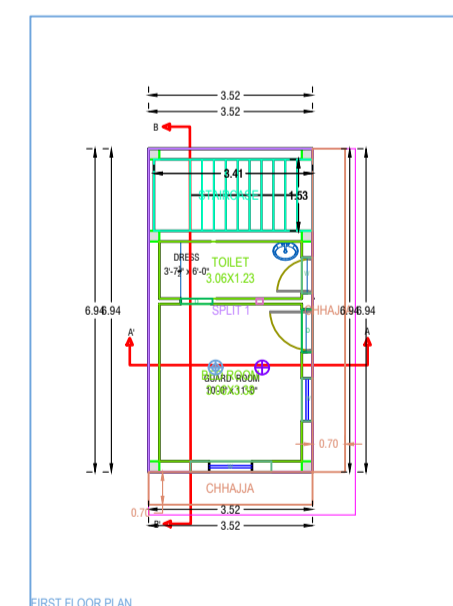
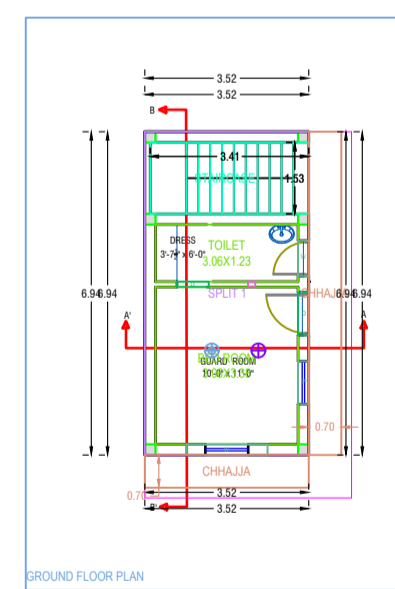
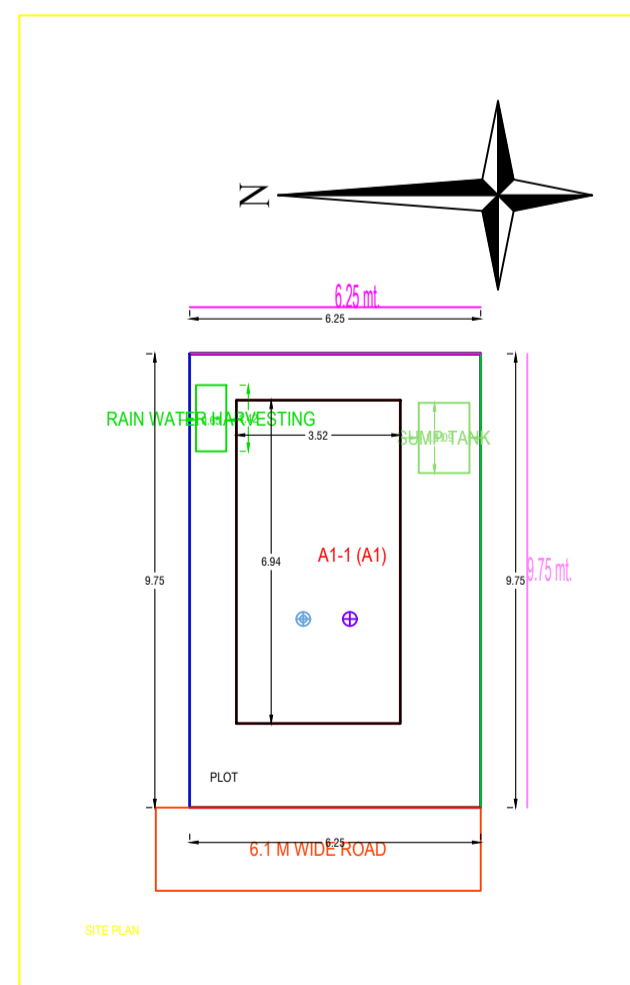

Building :A1 (A1)

Floor Name	Total Built Up Area (Sq.mt)	Proposed FAR Area (Sq.mt)	Total FAR Area (Sq.mt)	Tent (No.)
Ground Floor	24.45	24.45	24.45	01
First Floor	24.45	24.45	24.45	02
Terrace Floor	0.00	0.00	0.00	00
Total	48.90	48.90	48.90	01
Total Number of Same Buildings	1			
Total	48.90	48.90	48.90	01

SCHEDULE OF JOINERY:

BUILDING NAME	NAME	LENGTH	HEIGHT	NOS
A1 (A1)	D	0.88	2.10	02
A1 (A1)	D	0.92	2.10	02
Total	-	-	-	04

SCHEDULE OF JOINERY:

BUILDING NAME	NAME	LENGTH	HEIGHT	NOS
A1 (A1)	W	0.77	1.20	02
A1 (A1)	W	0.92	1.20	02
A1 (A1)	W	1.74	1.20	02
Total	-	-	-	06

UnIBUA Table for Building :A1 (A1)

FLOOR	Name	UnIBUA Type	UnIBUA Area	Carpet Area	No. of Rooms	No. of Tenement
GROUND FLOOR PLAN	SPLIT 1	FLAT	48.91	48.87	2	1
Total	-	-	48.91	48.87	4	1

AREA STATEMENT (SHANA) MUNICIPAL CORPORATION	VERSION NO. 1.0.36
PROJECT DETAIL	VERSION DATE: 18/03/2020
Plot No. -	Plot Use - Residential
Neighb - SHARWAD URBAN LOCAL BODIES	Plot Location - Shargwan Dwelling Non-Apartment
District - DHANBAD	Land Use Zone - NA
Application Type - General Proposal	Noticing Road Width -
Project Type - Building Permission	Plot No. -
Nature of Development - New	Revenue Survey No/Survey No. -
Location - 056 Area	Thana No. -
Sub Location - NA	Plotting No. -
Thana/Area Name -	Khasra No. -
Ward No. -	North -
Road/Street -	South -
	East -
	West -

AREA DETAILS

AREA OF PLOT (Minimum)	(A)	SQ.MT
Net Plot Area (Gross Plot Area - Deduction from Gross Plot area)	(A.Deductions)	60.93
Balance Plot Area (Net Plot Area - Home/Commercial/Industrial)	(A.Deductions)	60.93
Plot Area for Coverage (Net Plot Area)	(A.Deductions)	60.93
Plot Area for FSI (Net Plot Area - Road/Watering Area)	(A.Deductions)	60.93

COLOR INDEX

PILOT BOUNDARY	Green
ABUTTING ROAD	Black
PROPOSED WORK (COVERAGE AREA)	Red
EXISTING (To be retained)	Yellow
EXISTING (To be demolished)	Blue

MARGIN DETAIL

Building Wing	Road Name	Front Margin	Rear Margin	Side1 Margin	Side2 Margin
A1 (A1)	6.1 M WIDE ROAD	1.50	1.00	1.00	1.75

FAR & Tenement Details (Table 4c-1)

Building	No. of Same Bldg	Total Built Up Area (Sq.mt)	Proposed FAR Area (Sq.mt)	Total FAR Area (Sq.mt)	Tent (No.)
A1 (A1)	1	48.90	48.90	48.90	01
Total	1	48.90	48.90	48.90	01