

SITE PLAN
SCALE - 1" = 16'-0"

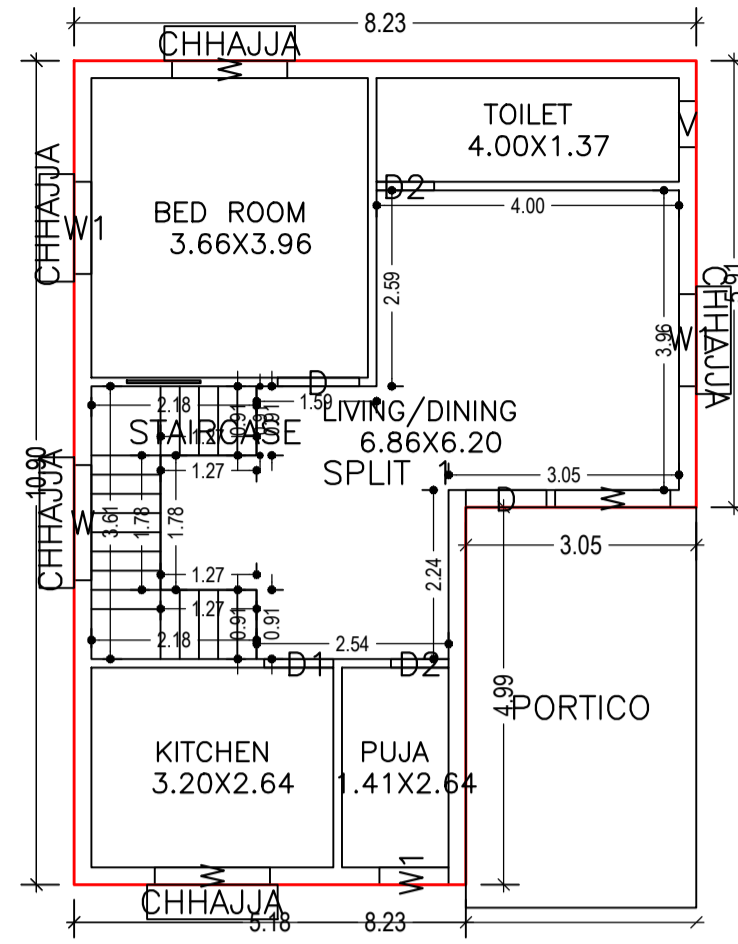

GROUND FLOOR PLAN (Proposed)
SCALE 1:100

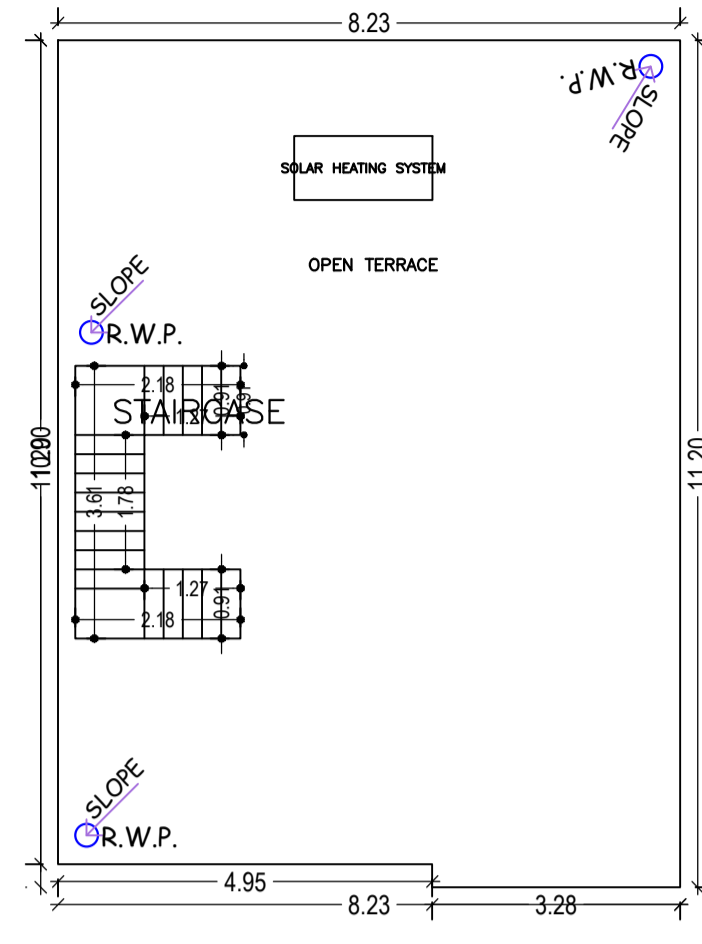

TERRACE FLOOR PLAN (SCALE 1:100)

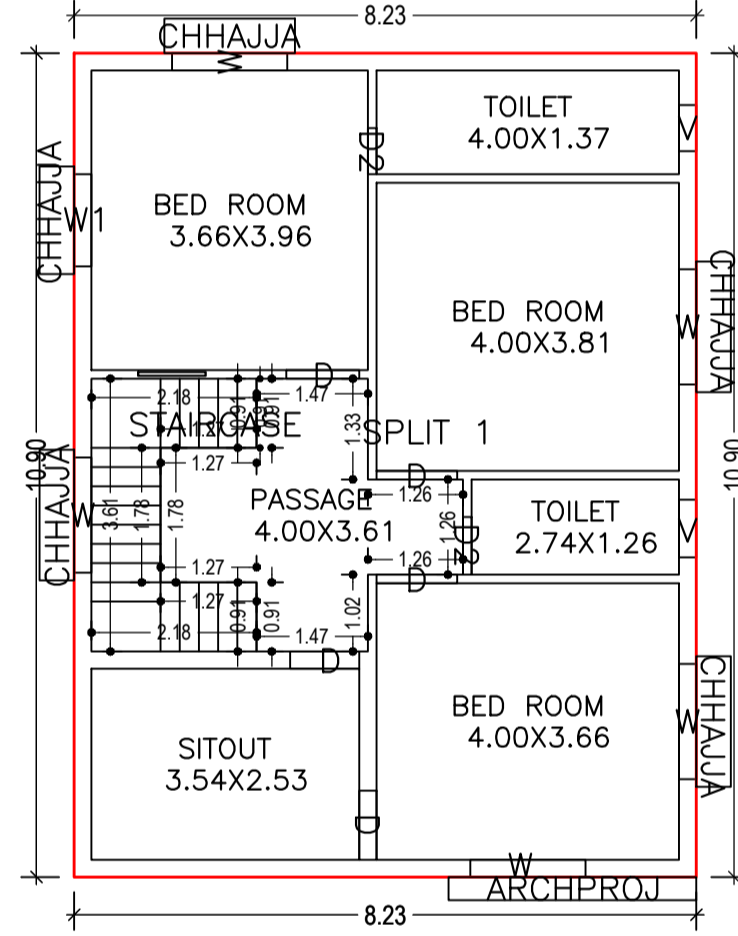

FIRST FLOOR PLAN (Proposed)
SCALE 1:100

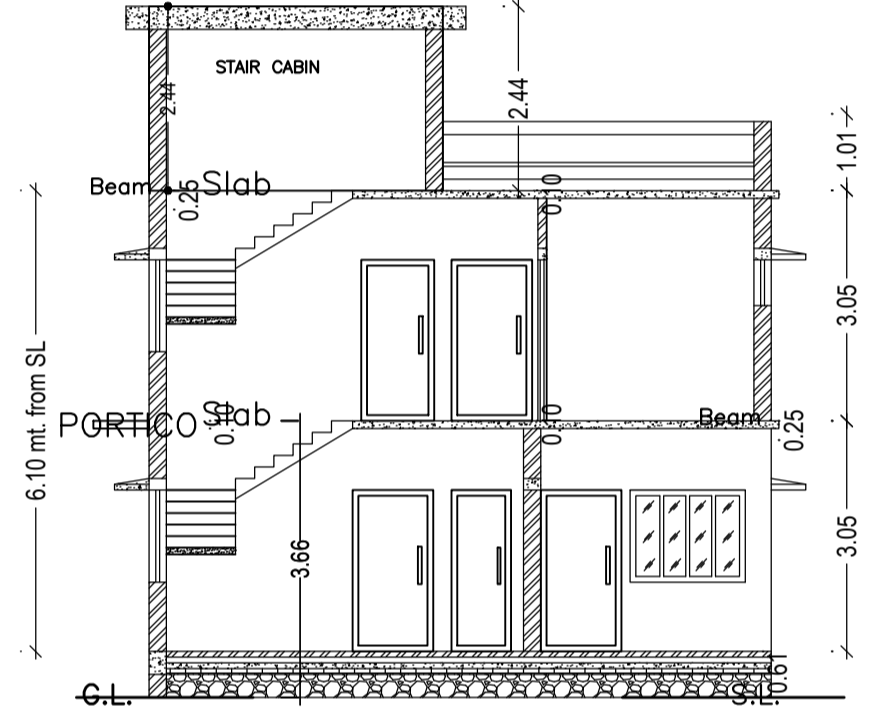

SECTION - XX'
SCALE - 1" = 8'-0"

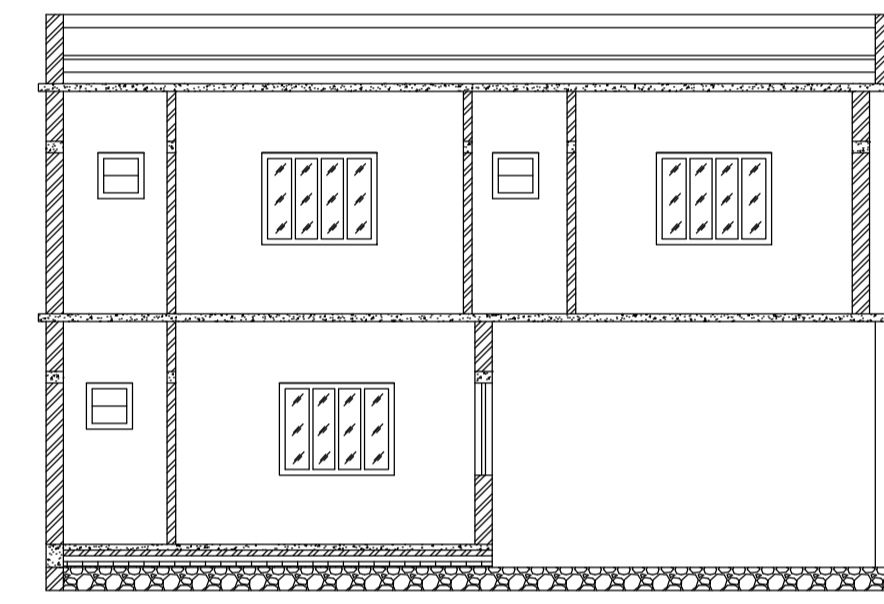

SECTION - YY'
SCALE - 1" = 8'-0"

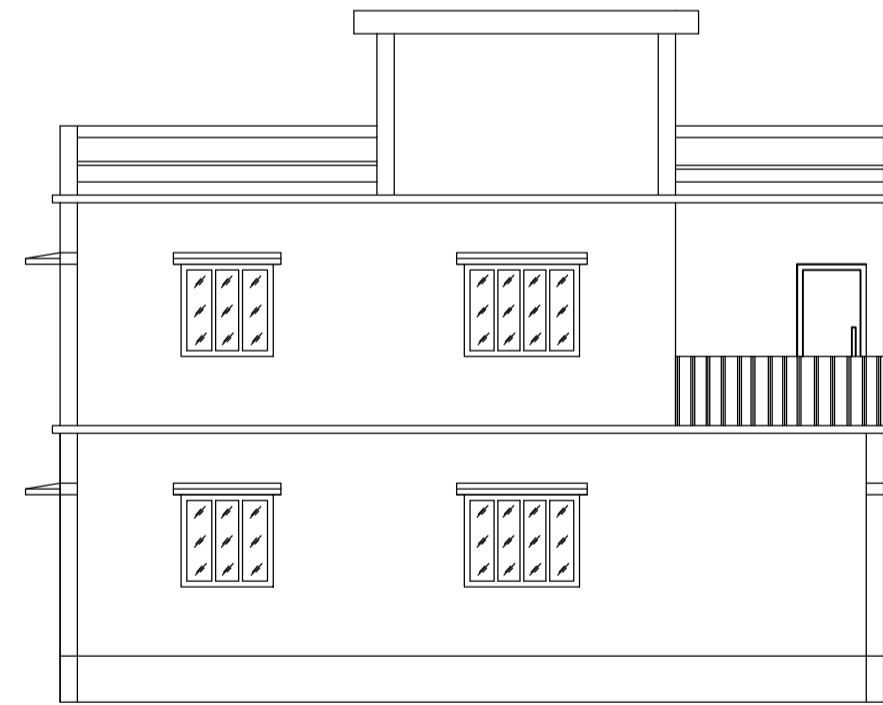

LEFT SIDE ELEVATION
SCALE - 1" = 8'-0"

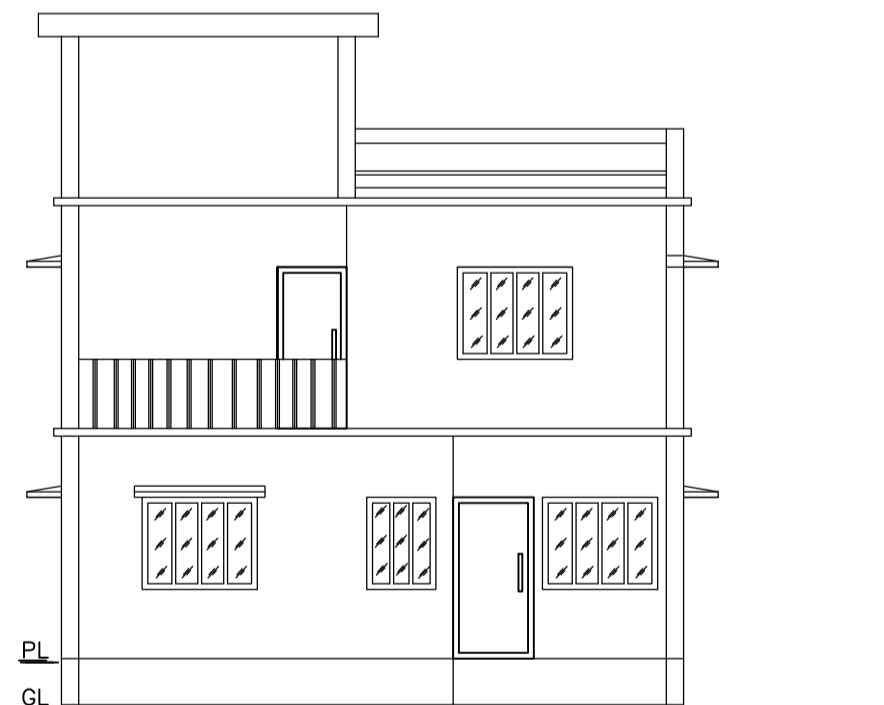

FRONT ELEVATION
SCALE - 1" = 8'-0"

FAR & Tenement Details (Table 4c-1)

Building	No. of Same Bldg	Total Built Up Area (Sq.mt.)	Deductions (Area in Sq.mt.) Archi.Proj.	Proposed FAR Area (Sq.mt.) Resi.	Total FAR Area (Sq.mt.)	Total Consumed Additional FAR Area (Sq.mt.)	Tnmt (No.)
A (MOHAMMAD ASIF ALI KHAN)	1	180.25	16.14	164.11	164.11	164.11	01
Grand Total :	1	180.25	16.14	164.11	164.11	164.11	01

Proposal Basic Information

Proposal File No.	MADA/BP/0397/2023
Owner Name	MOHAMMAD ASIF ALI KHAN
Khata No	OLD KHATA NO-43, NEW KHATA NO-350
Plot No	OLD PLOT NO-2562, NEW PLOT NO-4003
Village Name	Bara Pichri
Use	Residential
SubUse	Bungalow/ Dwelling / Non Apartment

AREA STATEMENT MINERAL AREA DEVELOPMENT AUTHORITY	VERSION NO : 1.0.68
PROJECT DETAIL:	VERSION DATE: 16/10/2020
Region: JHARKHAND URBAN LOCAL BODIES	Plot Use: Residential
District: DHANBAD	Plot SubUse: Bungalow/ Dwelling / Non Apartment
Authority: MINERAL AREA DEVELOPMENT AUTHORITY	PlotNearby/ReligiousStructure: NA
Inward No: MADA/BP/0397/2023	Plot/SubPlot No: OLD PLOT NO-2562, NEW PLOT NO-4003
Application Type: General Proposal	North: Plot No. - SAME PLOT
Project Type: Building Permission	South: Plot No. - SAME PLOT
Nature of Development: New	East: Road Width - 6.10
Location of Development Area: Old Area	West: Plot No. - SAME PLOT

AREA DETAILS:		SQ.MT.
AREA OF PLOT (Minimum)	(A)	152.68
NET AREA OF PLOT(Gross Plot Area - Deduction from Gross Plot area)	(A-Deductions)	152.68
Deduction for Balance Plot Area(from Gross Plot Area)		
Common Plot		17.32
Total		17.32
BALANCE AREA OF PLOT(Net Plot Area - Recreational/Amenity space)	(A-Deductions)	135.36
PLOT AREA FOR COVERAGE(Net Plot Area)	(A-Deductions)	152.68
Plot Area for FAR (Net Plot Area + Road Widening Area)	(A-Deductions)	152.68

COVERAGE CHECK		
Permissible Coverage area (70.00 %)		106.88
Proposed Coverage Area (48.76 %)		74.45
Total Prop. Coverage Area (48.76 %)		74.45
Balance coverage area (21.24 %)		32.43
FAR CHECK		
Perm. FAR Area (2.500)		381.70
Total Perm. FAR area		381.70
Residential FAR		164.11
Proposed FAR Area		164.11
Total Proposed FAR Area		164.11
Consumed FAR (Factor)		1.07
Balance FAR Area		217.59
BUILT UP AREA CHECK		
Total Proposed BuiltUp Area		180.25
ARCHITECT (Regd)		
		RAM PRATAP SINGH
ENGINEER (Regd)		
SUPERVISOR (Regd)		
OWNER (Regd)		
		MOHAMMAD ASIF ALI KHAN
DEVELOPMENT AUTHORITY		
		LOCAL BODY

COLOR INDEX	
PLOT BOUNDARY	Black
ABUTTING ROAD	Green
PROPOSED CONSTRUCTION	Red
COMMON PLOT	Yellow
ROAD WIDENING AREA	Blue
EXISTING (To be retained)	Light Blue
EXISTING (To be demolished)	Light Yellow

SCHEDULE OF DOOR:

BUILDING NAME	NAME	LENGTH	HEIGHT	NOS
A (MOHAMMAD ASIF ALI KHAN)	D2	0.61	2.10	01
A (MOHAMMAD ASIF ALI KHAN)	D2	0.76	2.10	03
A (MOHAMMAD ASIF ALI KHAN)	D	0.91	2.10	02
A (MOHAMMAD ASIF ALI KHAN)	D1	0.91	2.10	01
A (MOHAMMAD ASIF ALI KHAN)	D	0.97	2.10	01
A (MOHAMMAD ASIF ALI KHAN)	D	1.07	2.10	03
A (MOHAMMAD ASIF ALI KHAN)	D	1.08	2.10	01

SCHEDULE OF WINDOW/VENTILATION:

BUILDING NAME	NAME	LENGTH	HEIGHT	NOS
A (MOHAMMAD ASIF ALI KHAN)	V	0.61	1.20	02
A (MOHAMMAD ASIF ALI KHAN)	V	0.76	1.20	01
A (MOHAMMAD ASIF ALI KHAN)	W1	0.91	1.20	01
A (MOHAMMAD ASIF ALI KHAN)	W1	1.22	1.20	03
A (MOHAMMAD ASIF ALI KHAN)	W	1.52	1.20	09

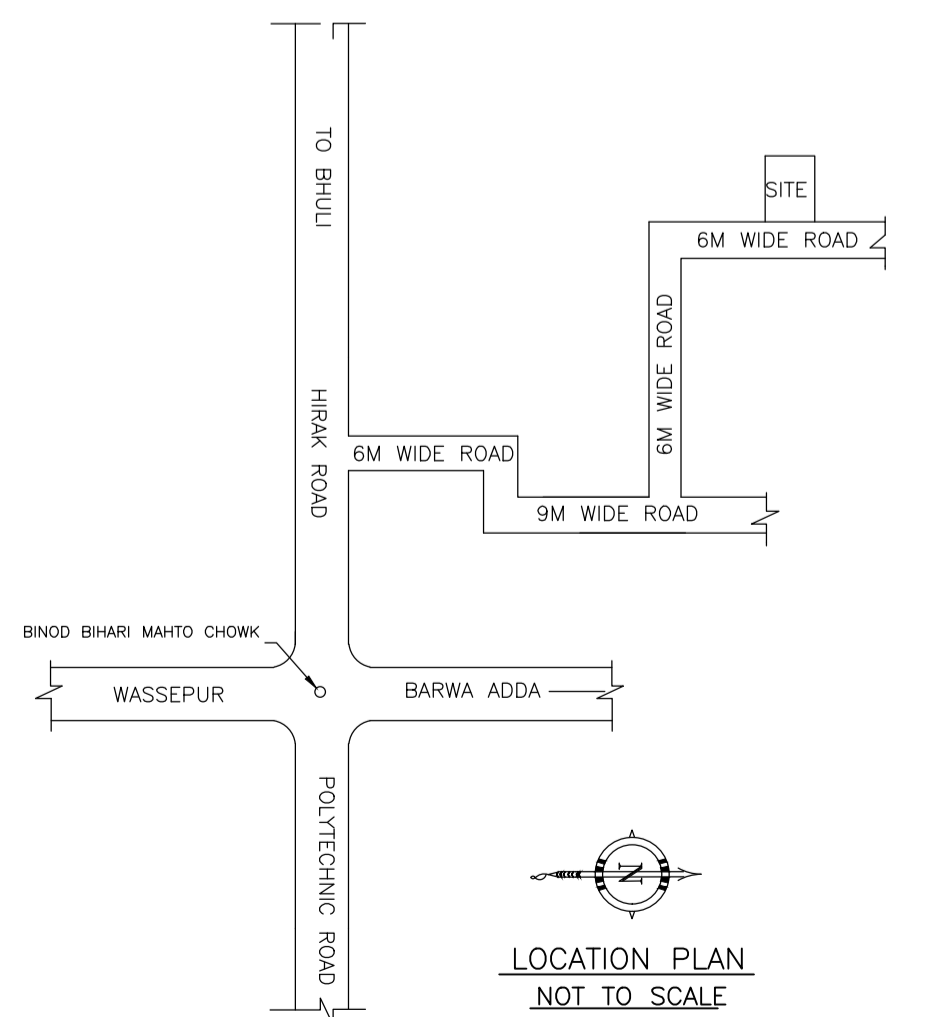

LOCATION PLAN
NOT TO SCALE

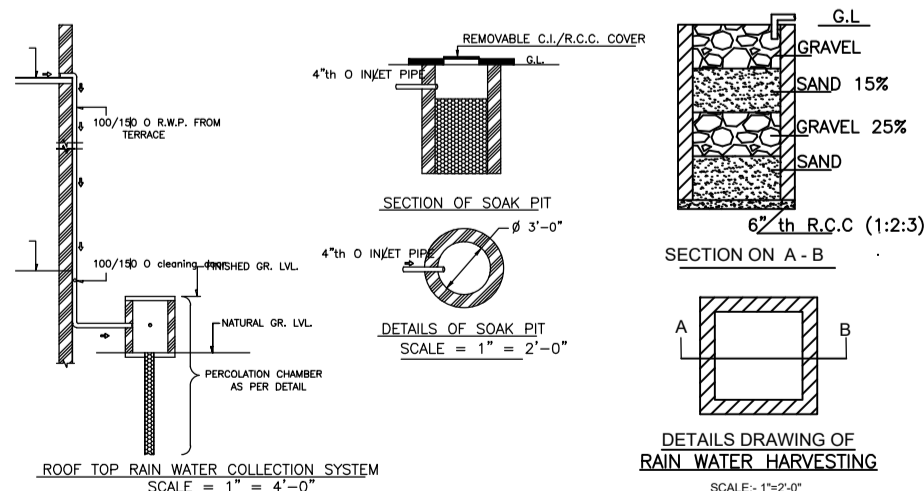

Building :A (MOHAMMAD ASIF ALI KHAN)

Floor Name	Total Built Up Area (Sq.mt.)	Deductions (Area in Sq.mt.) Archi.Proj.	Proposed FAR Area (Sq.mt.) Resi.	Total FAR Area (Sq.mt.)	Total Consumed Additional FAR Area (Sq.mt.)	Tnmt (No.)
Ground Floor	90.59	16.14	74.45	74.45	74.45	01
First Floor	89.66	0.00	89.66	89.66	89.66	00
Terrace Floor	0.00	0.00	0.00	0.00	0.00	00
Total :	180.25	16.14	164.11	164.11	164.11	01
Total Number of Same Buildings :	1					
Total :	180.25	16.14	164.11	164.11	164.11	01

UnitBUA Table for Building :A (MOHAMMAD ASIF ALI KHAN)

FLOOR	Name	UnitBUA Type	UnitBUA Area	Carpet Area	No. of Rooms	No. of Tenement
GROUND FLOOR PLAN	SPLIT 1	FLAT	147.04	146.97	5	1
FIRST FLOOR PLAN	SPLIT 1	FLAT	0.00	0.00	7	0
Total:	-	-	147.04	146.97	12	1

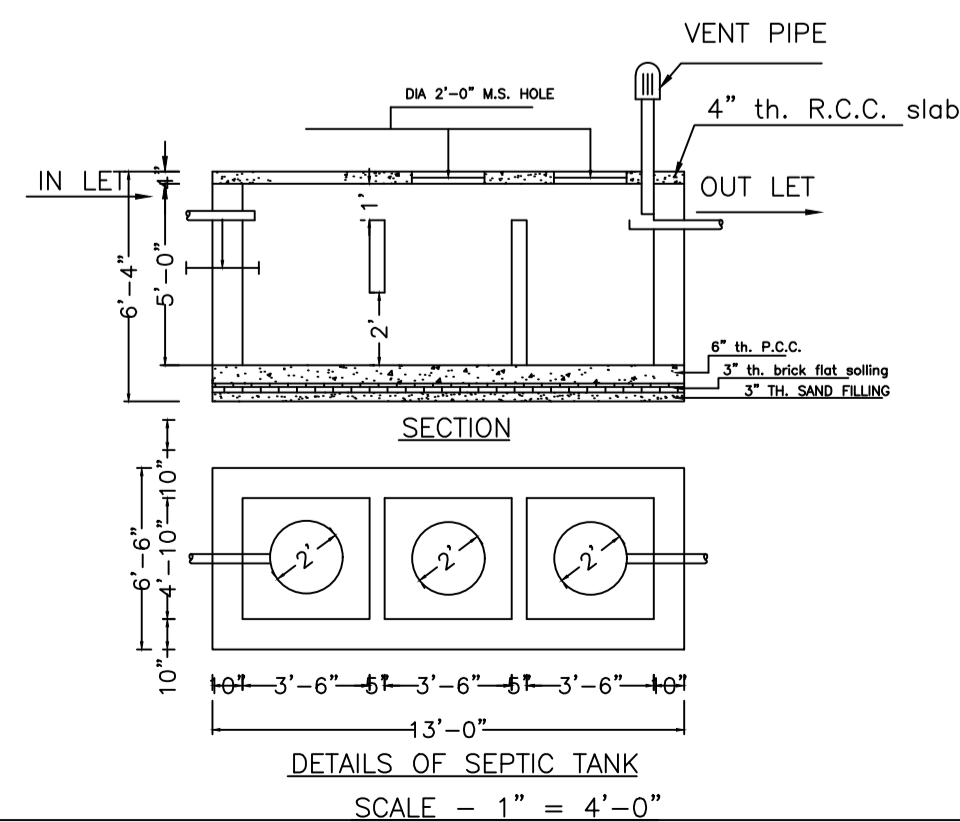

DETAILS OF SEPTIC TANK
SCALE - 1" = 4'-0"

Buildingwise Floor FAR Details

Floor Name	Building Name		Total	
	Proposed Built Up Area (Sq.mt.)	Proposed FAR Area (Sq.mt.)	Total Proposed Built Up Area (Sq.mt.)	Total FAR Area (Sq.mt.)
Ground Floor	90.59	74.45	90.59	74.45
First Floor	89.66	89.66	89.66	89.66
Terrace Floor	0.00	0.00	0.00	0.00
Total :	180.25	164.11	180.25	164.11

Building USE/SUBUSE Details

Building Name	Building Use	Building SubUse	Building Structure
A (MOHAMMAD ASIF ALI KHAN)	Residential	Bungalow/ Dwelling / Non Apartment	Non-Highrise

LTP NAME AND SIGNATURE	STRUCTURAL ENG'S NAME AND SIGNATURE	BUILDER NAME AND SIGNATURE	DIGITAL SIGNATURE
RAM PRATAP SINGH MADA/ARC/0024/2019			