

FAR & Tenement Details (Table 4c-1)

Building	No. of Same Bldg	Gross Built Up Area (Sq.mt.)	Deductions From Gross BUA/Area in Sq.mt. Cutout	Total Built Up Area (Sq.mt.)	Proposed FAR Area (Sq.mt.) Resi.	Total FAR Area (Sq.mt.)	Total Consumed Additional FAR Area (Sq.mt.)	Tnmt (No.)
RESI (SUBODH)	1	217.01	5.88	211.13	211.13	211.13	211.13	01
<b>Grand Total :</b>	<b>1</b>	<b>217.01</b>	<b>5.88</b>	<b>211.13</b>	<b>211.13</b>	<b>211.13</b>	<b>211.13</b>	<b>01</b>

Proposal Basic Information

Proposal File No.	MADA/BP/0388/2023
Owner Name	SRI SUBODH PRASAD
Khata No	09 (OLD), 215 (NEW)
Plot No	545 (OLD), 590 (NEW)
Village Name	Amaghata
Use	Residential
SubUse	Bungalow/ Dwelling / Non Apartment

AREA STATEMENT MINERAL AREA DEVELOPMENT AUTHORITY

VERSION NO. : 1.0.67	VERSION DATE: 16/10/2020
Region: JHARKHAND URBAN LOCAL BODIES	Plot Use: Residential
District: DHANBAD	Plot SubUse: Bungalow/ Dwelling / Non Apartment
Authority: MINERAL AREA DEVELOPMENT AUTHORITY	PlotNearby/ReligiousStructure: NA
Inward No: MADA/BP/0388/2023	PlotSubPlot No: 545 (OLD), 590 (NEW)
Application Type: General Proposal	North: Plot No. - lot no-109
Project Type: Building Permission	South: Plot No. - VACANT LAND
Nature of Development: New	East: Road Width - 9.14
Location of Development Area: Old Area	West: Plot No. - LOT NO-58

AREA DETAILS:

AREA OF PLOT (Minimum)	(A)	SQ.MT.
NET AREA OF PLOT (Gross Plot Area - Deduction from Gross Plot area)	(A-Deductions)	166.89
Deduction for Balance Plot Area (from Gross Plot Area)		
Common Plot		16.89
Total		166.89
BALANCE AREA OF PLOT (Net Plot Area - Recreational/Amenity space)	(A-Deductions)	150.00
PLOT AREA FOR COVERAGE (Net Plot Area)	(A-Deductions)	166.89
Plot Area for FAR (Net Plot Area + Road Widening Area)	(A-Deductions)	166.89

COVERAGE CHECK

Permissible Coverage area ( 70.00 % )	116.82
Proposed Coverage Area ( 63.08 % )	105.27
Total Prop. Coverage Area ( 63.08 % )	105.27
Balance coverage area ( 6.92 % )	11.55

FAR CHECK

Perm. FAR Area ( 2.500 )	417.23
Total Perm. FAR area	417.23
Residential FAR	211.13
Proposed FAR Area	211.13
Total Proposed FAR Area	211.13
Consumed FAR (Factor)	1.27
Balance FAR Area	206.10

BUILT UP AREA CHECK

Total Proposed BuiltUp Area	211.13
-----------------------------	--------

ARCHITECT (Regd) ANIL KUMAR CHAUDHARY  
ENGINEER (Regd)  
SUPERVISOR (Regd)  
OWNER (Regd) SRI SUBODH PRASAD  
DEVELOPMENT AUTHORITY LOCAL BODY

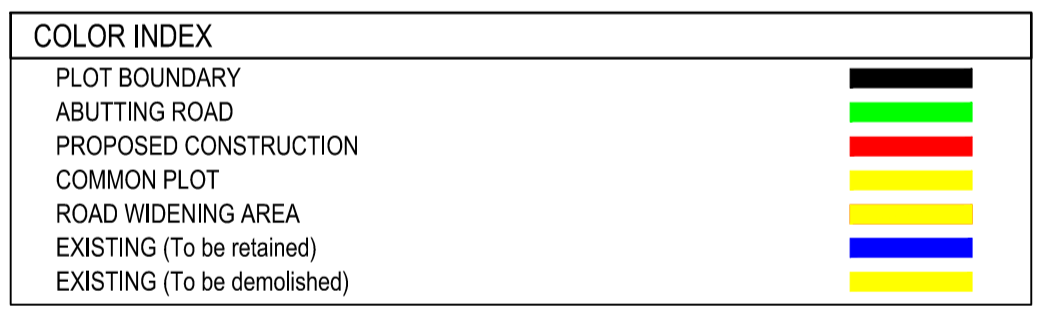

Buildingwise Floor FAR Details

Floor Name	Building Name RESI (SUBODH)		Total	
	Proposed Built Up Area (Sq.mt.)	Proposed FAR Area (Sq.mt.)	Total Proposed Built Up Area (Sq.mt.)	Total FAR Area (Sq.mt.)
Ground Floor	105.27	105.27	105.27	105.27
First Floor	105.86	105.86	105.86	105.86
Terrace Floor	0.00	0.00	0.00	0.00
<b>Total :</b>	<b>211.13</b>	<b>211.13</b>	<b>211.13</b>	<b>211.13</b>

Building USE/SUBUSE Details

Building Name	Building Use	Building SubUse	Building Structure
RESI (SUBODH)	Residential	Bungalow/ Dwelling / Non Apartment	Non-Highrise

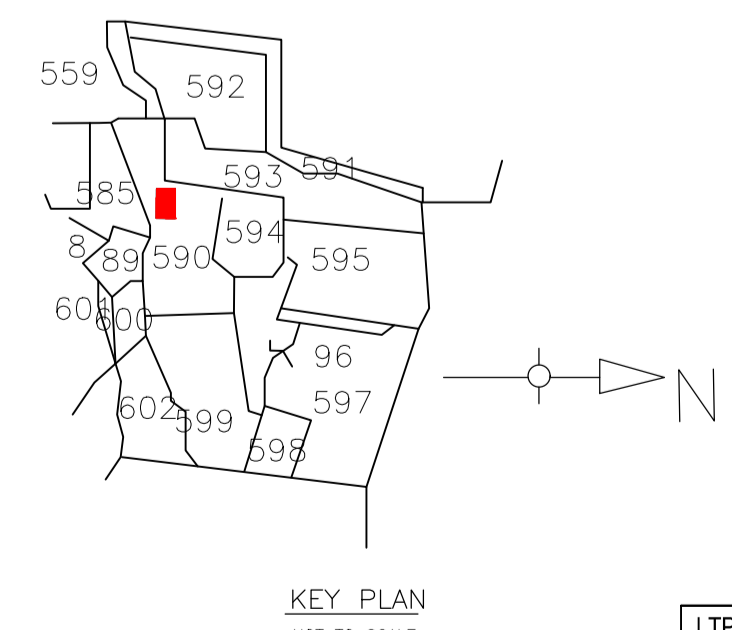
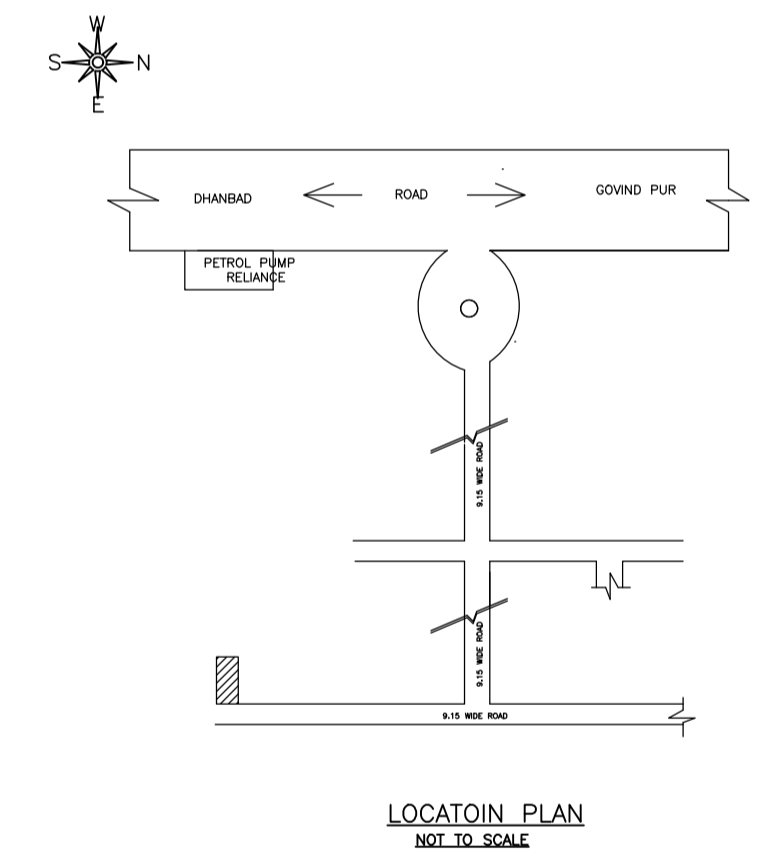
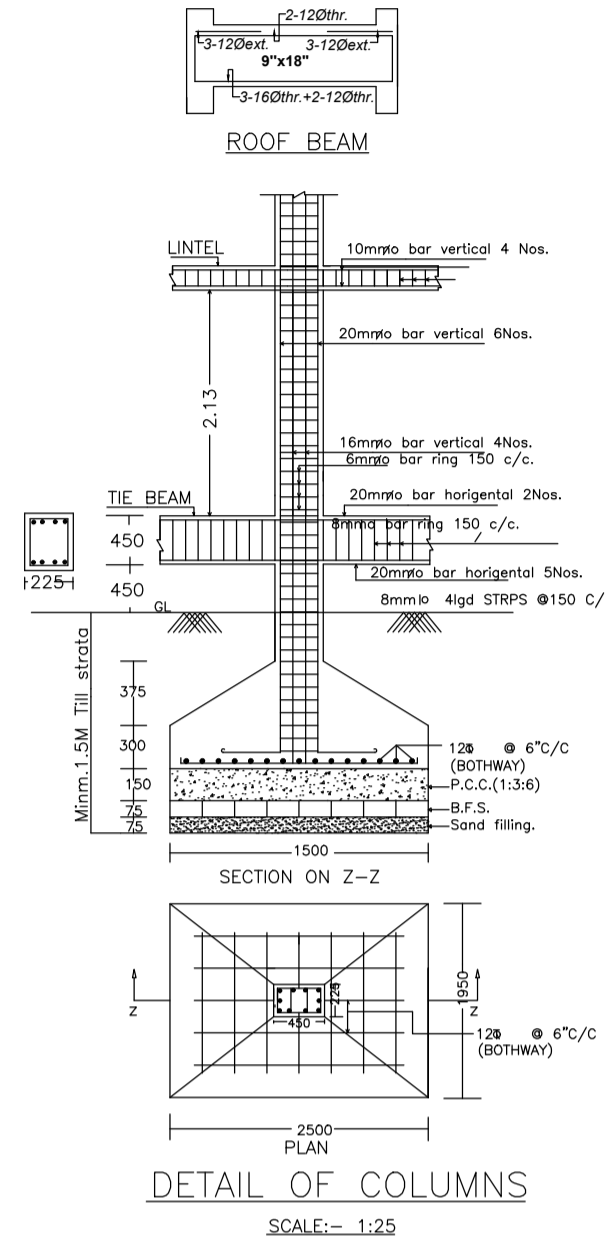
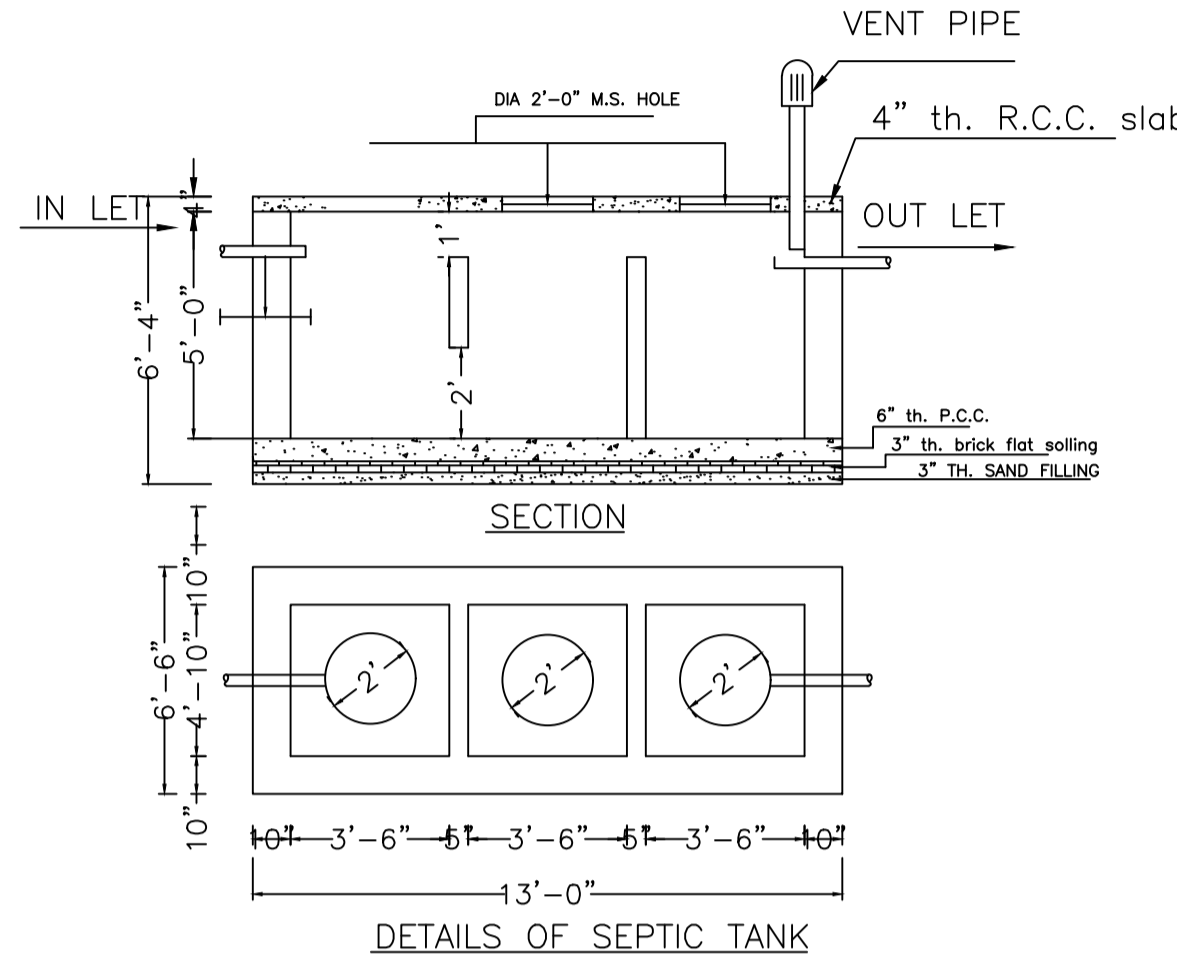

LTP NAME AND SIGNATURE	STRUCTURAL ENG'S NAME AND SIGNATURE	BUILDER NAME AND SIGNATURE	DIGITAL SIGNATURE
ANIL KUMAR CHAUDHARY MADA/ENG/0005/2019			



Proposal Basic Information	
Proposal File No.	MADA/BP/0388/2023
Owner Name	SRI SUBODH PRASAD
Khata No	09 (OLD), 215 (NEW)
Plot No	545 (OLD), 590 (NEW)
Village Name	Amaghata
Use	Residential
SubUse	Bungalow/ Dwelling / Non Apartment

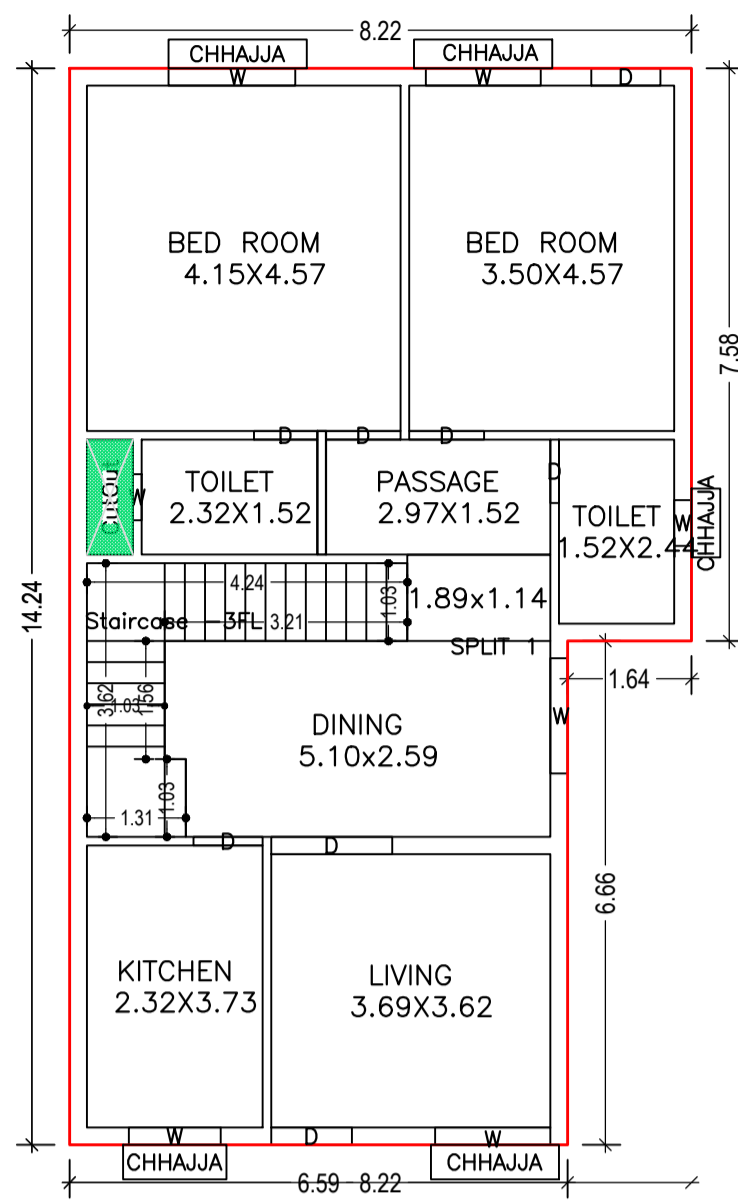

GROUND FLOOR PLAN (Proposed) (SCALE 1:100)

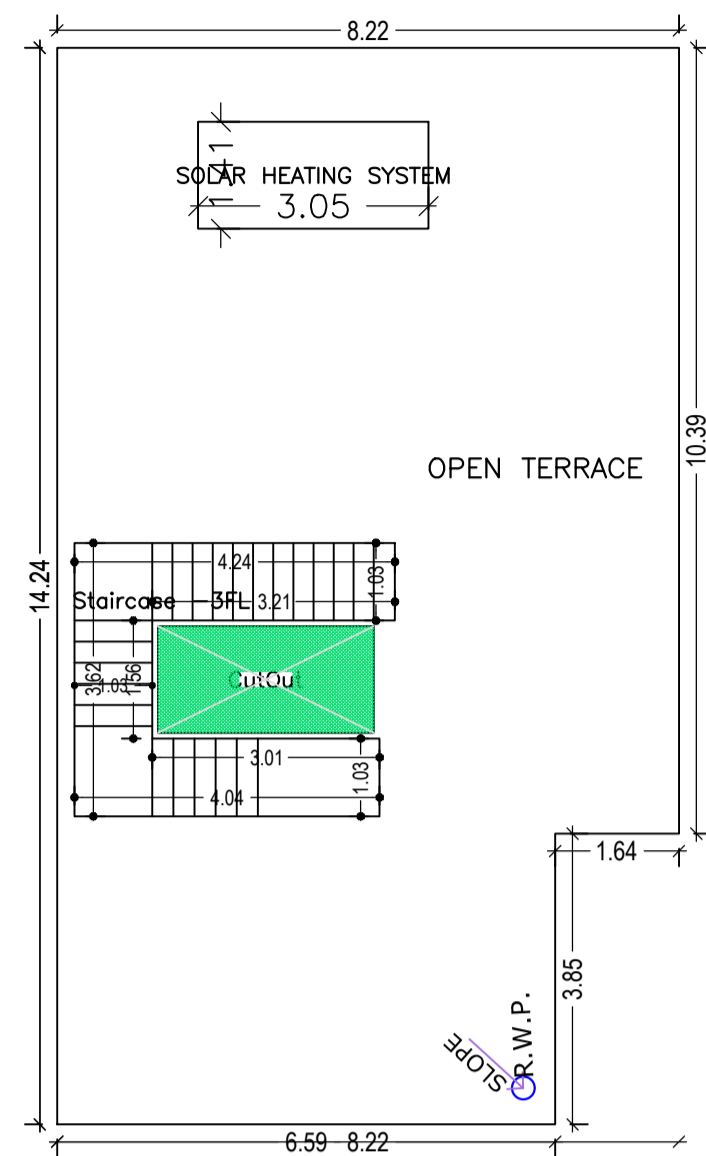

TERRACE FLOOR PLAN (SCALE 1:100)

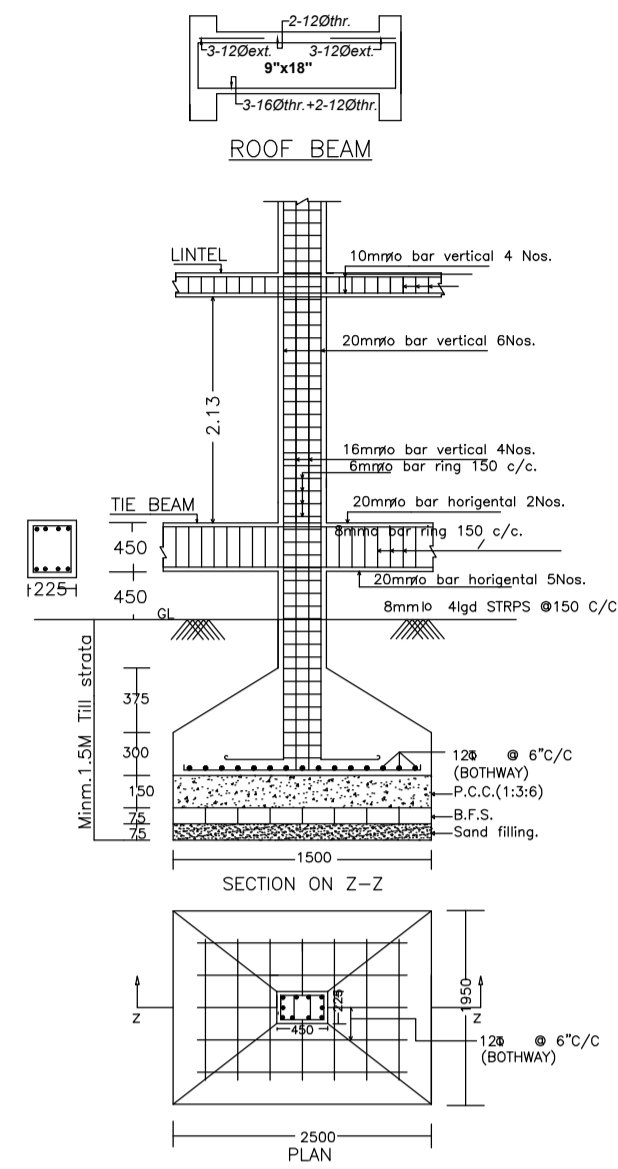

DETAIL OF COLUMNS (SCALE = 1:25)

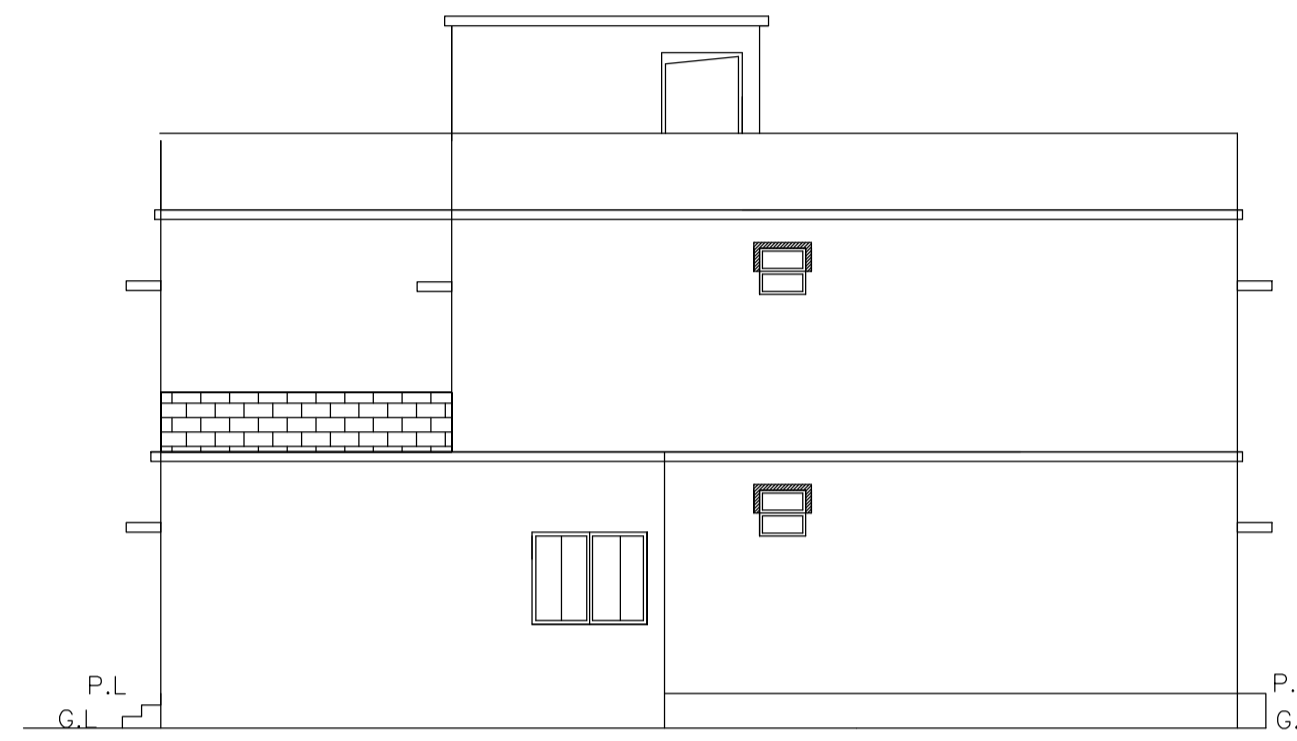

RIGHT SIDE ELEVATION



FRONT ELEVATION

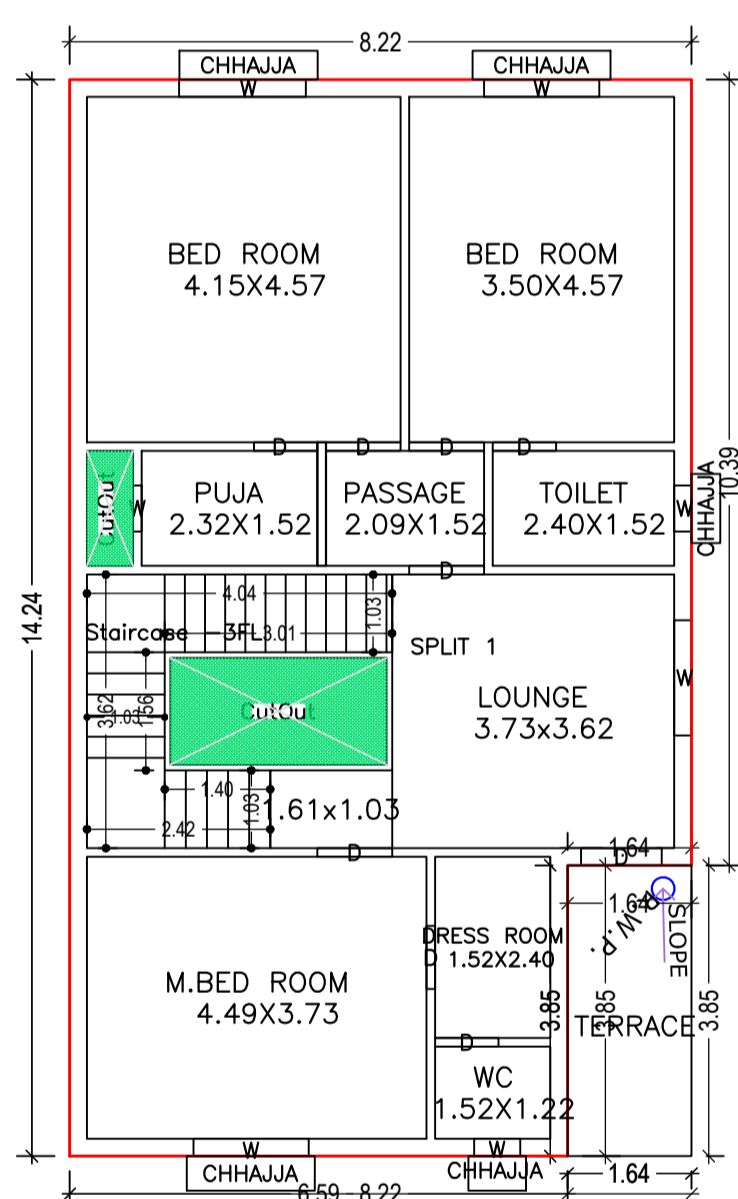
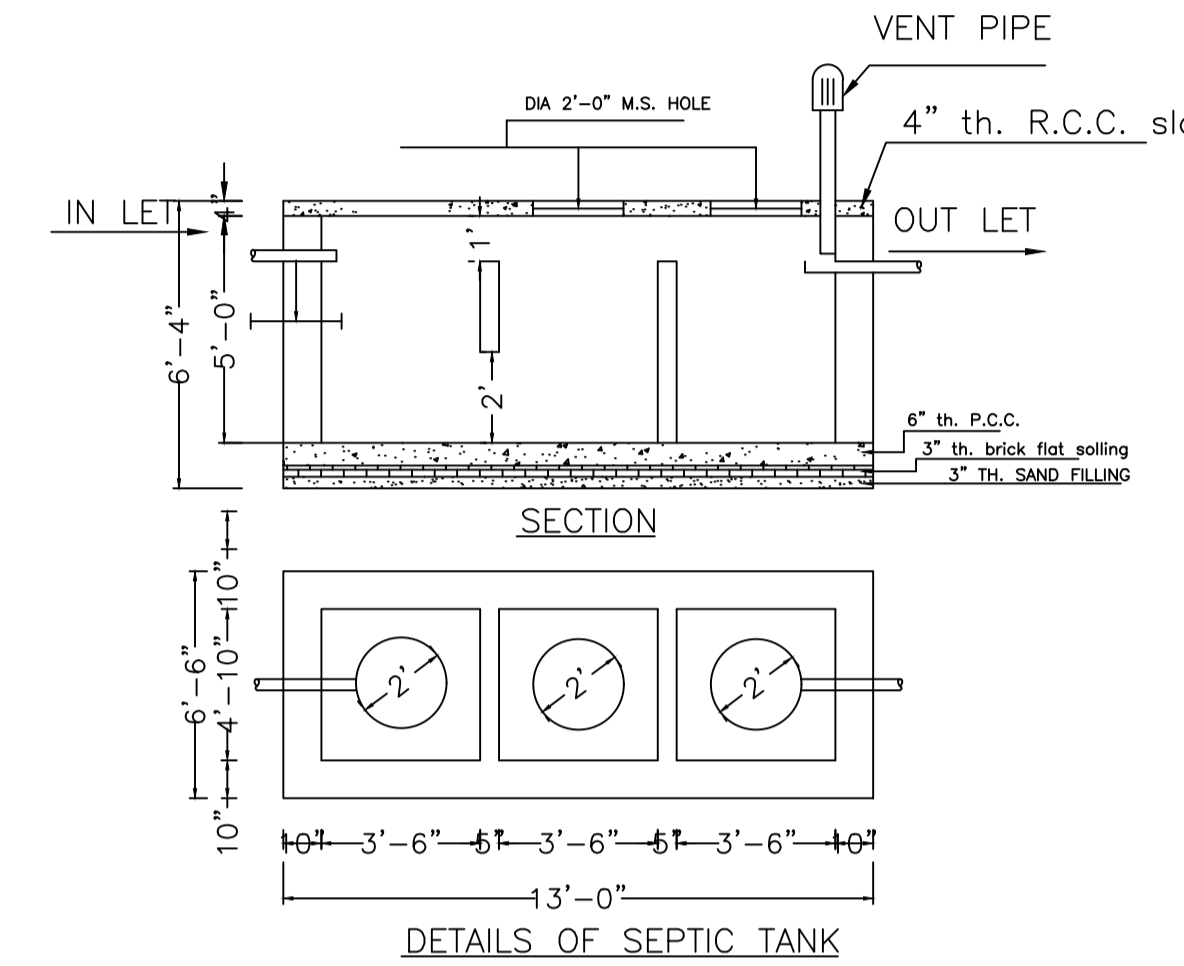

FIRST FLOOR PLAN (Proposed) (SCALE 1:100)

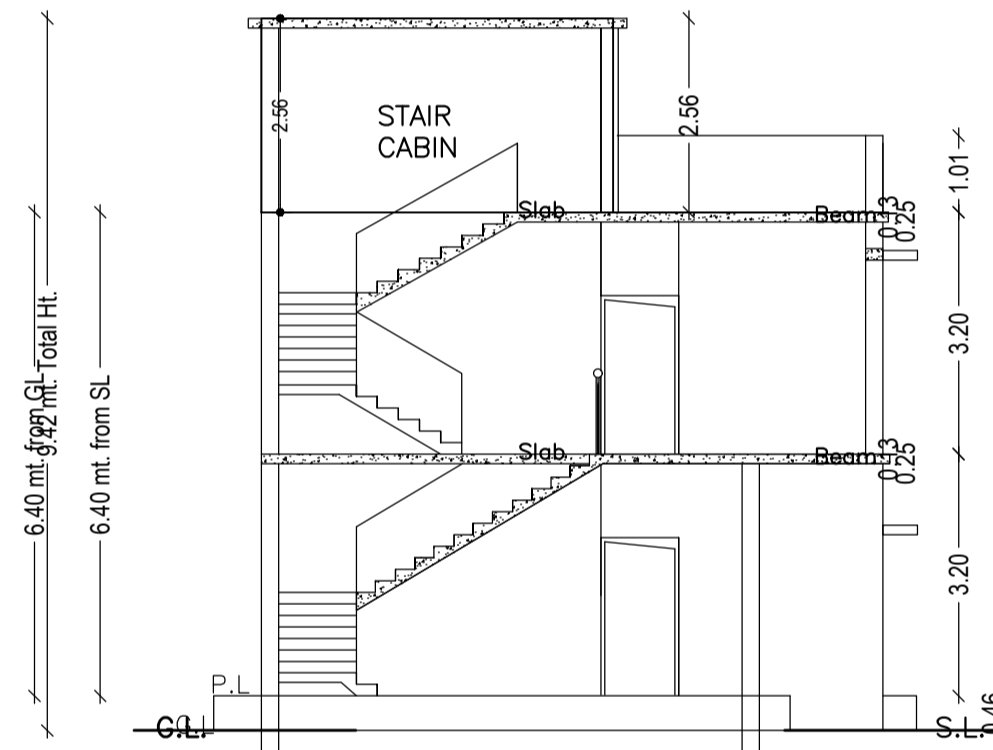

SECTION AT X-X

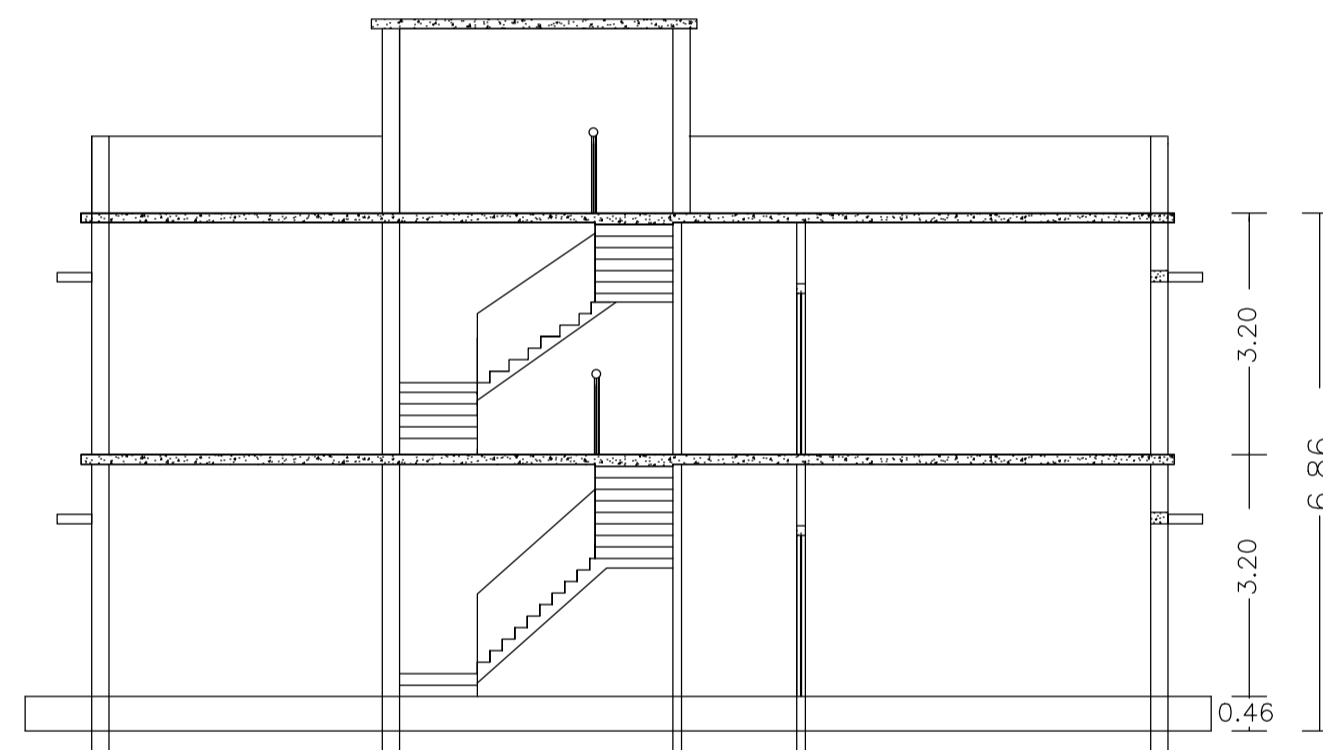

SECTION AT Y-Y

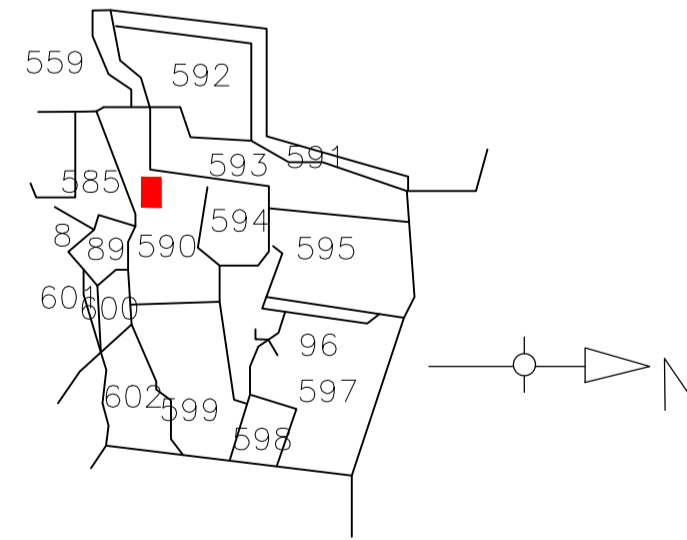

KEY PLAN (NOT TO SCALE)

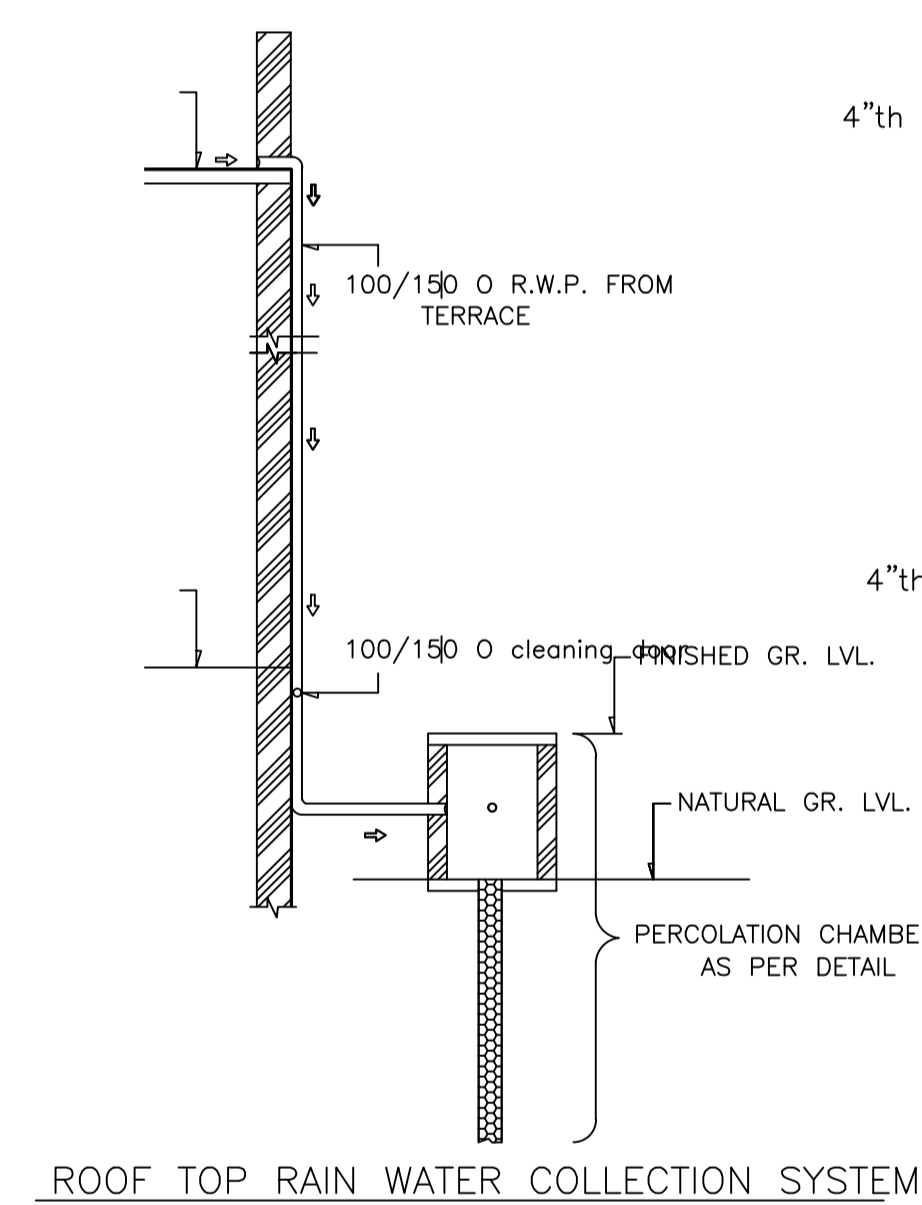

ROOF TOP RAIN WATER COLLECTION SYSTEM

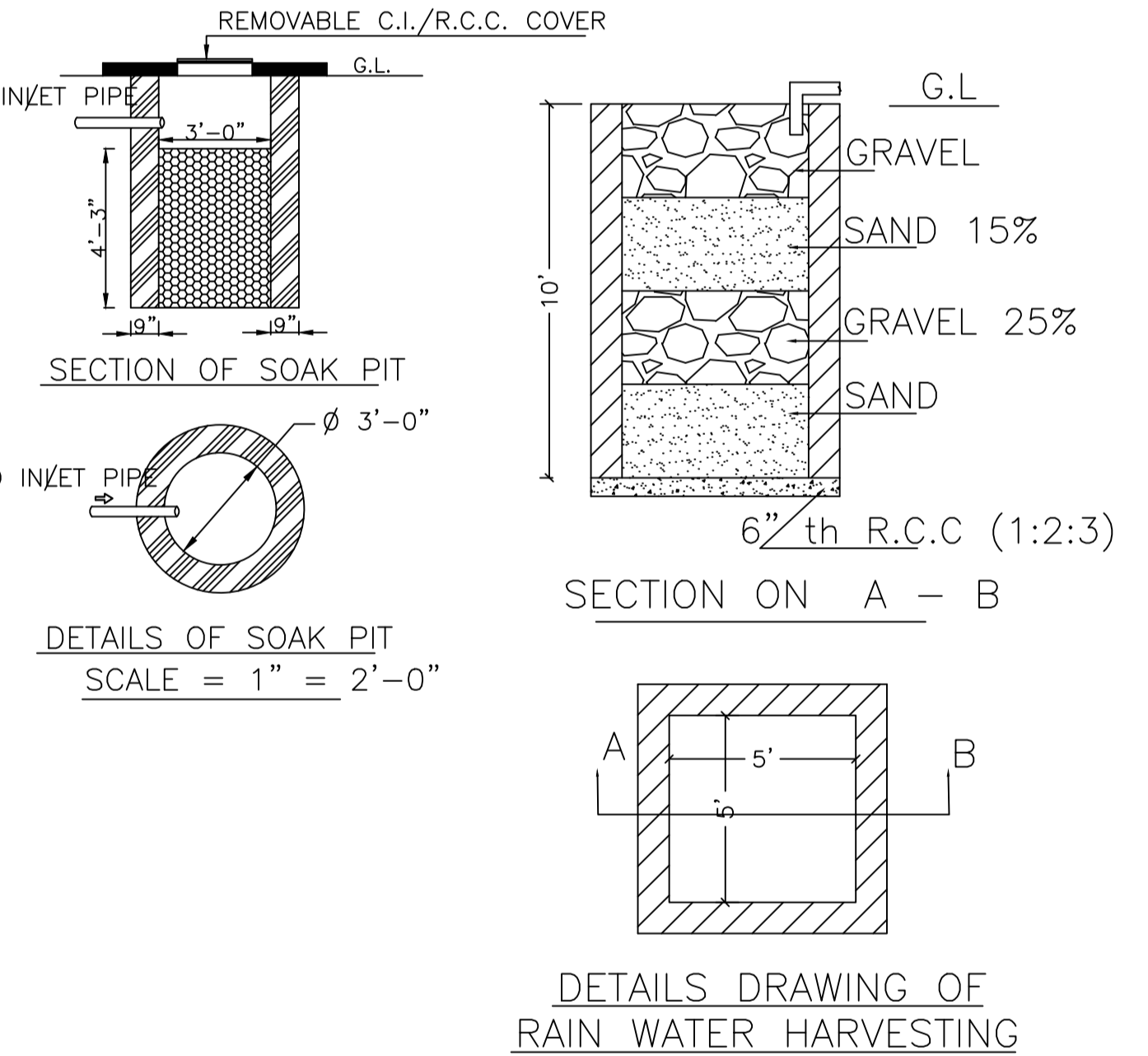

DETAILS DRAWING OF RAIN WATER HARVESTING

Building :RESI (SUBODH)

Floor Name	Gross Builtup Area	Deductions From Gross BUA (Area in Sq.mt.)	Total Built Up Area (Sq.mt.)	Proposed FAR Area (Sq.mt.)	Total FAR Area (Sq.mt.)	Total Consumed Additional FAR Area (Sq.mt.)	Tnmt (No.)
Ground Floor	106.20	0.93	105.27	105.27	105.27	105.27	01
First Floor	110.81	4.95	105.86	105.86	105.86	105.86	00
Terrace Floor	0.00	0.00	0.00	0.00	0.00	0.00	00
Total :	217.01	5.88	211.13	211.13	211.13	211.13	01
Total Number of Same Buildings	1						
Total :	217.01	5.88	211.13	211.13	211.13	211.13	01

SCHEDULE OF DOOR:

BUILDING NAME	NAME	LENGTH	HEIGHT	NOS
RESI (SUBODH)	D	0.84	2.10	06
RESI (SUBODH)	D	0.91	2.10	02
RESI (SUBODH)	D	0.99	2.10	06
RESI (SUBODH)	D	1.07	2.10	02
RESI (SUBODH)	D	1.60	2.10	01

SCHEDULE OF WINDOW/VENTILATION:

BUILDING NAME	NAME	LENGTH	HEIGHT	NOS
RESI (SUBODH)	W	0.61	1.20	05
RESI (SUBODH)	W	1.22	1.20	01
RESI (SUBODH)	W	1.52	1.20	06
RESI (SUBODH)	W	1.68	1.20	02

UnitBUA Table for Building :RESI (SUBODH)

FLOOR	Name	UnitBUA Type	UnitBUA Area	Carpet Area	No. of Rooms	No. of Tenement
GROUND FLOOR PLAN	SPLIT 1	FLAT	211.13	210.75	8	1
FIRST FLOOR PLAN	SPLIT 1	FLAT	0.00	0.00	9	0
Total:	-	-	211.13	210.75	17	1

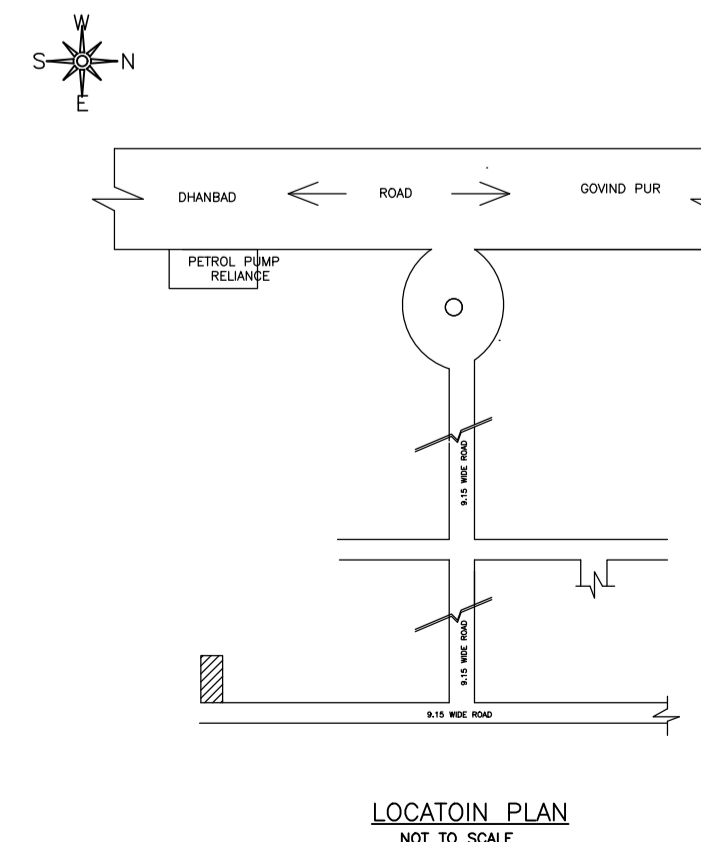

LOCATION PLAN (NOT TO SCALE)

LTP NAME AND SIGNATURE	STRUCTURAL ENG'S NAME AND SIGNATURE	BUILDER NAME AND SIGNATURE	DIGITAL SIGNATURE
ANIL KUMAR CHAUDHARY MADA/ENG/0005/2019			