

Project Title : GAURI BALA DEVI

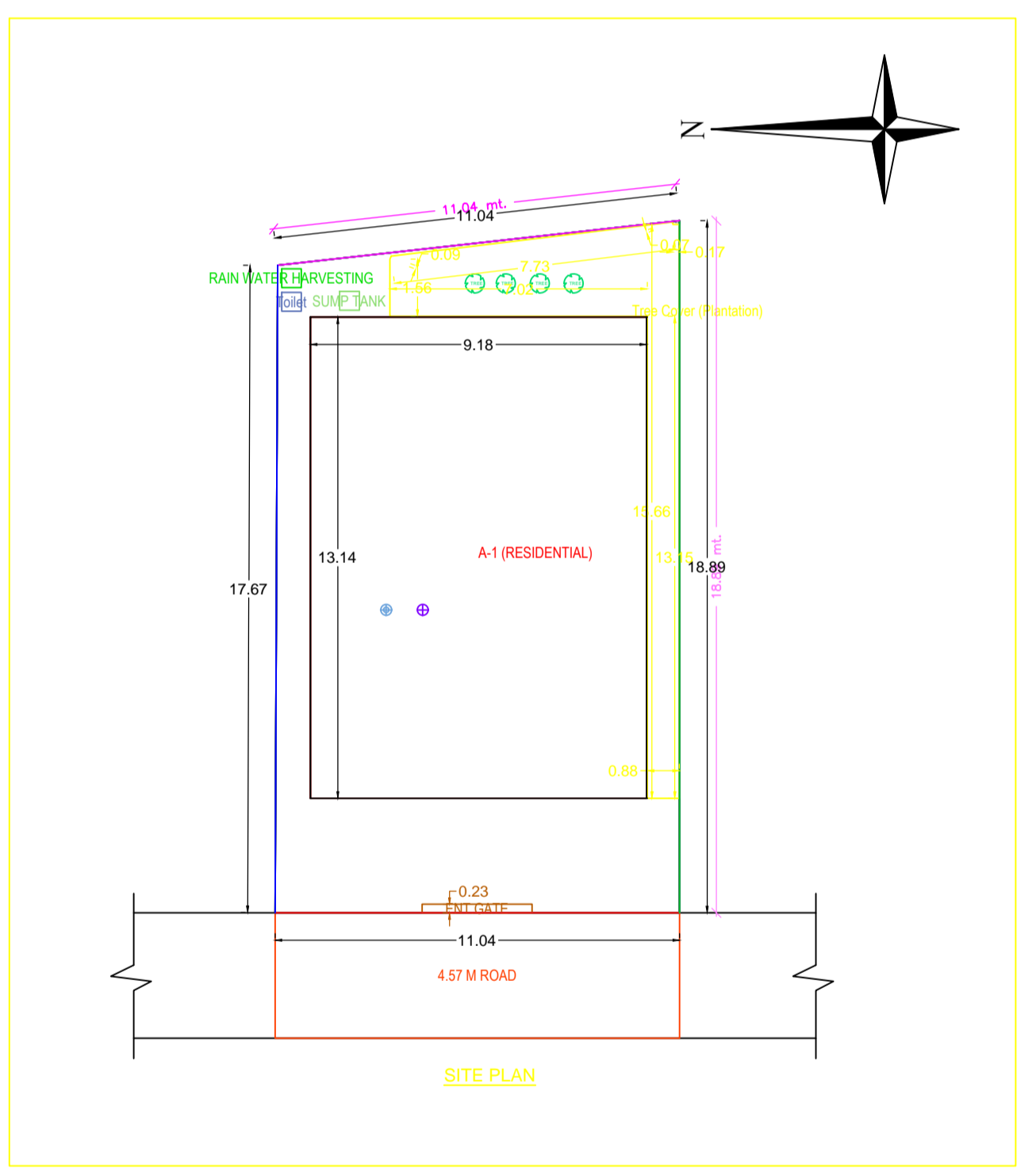
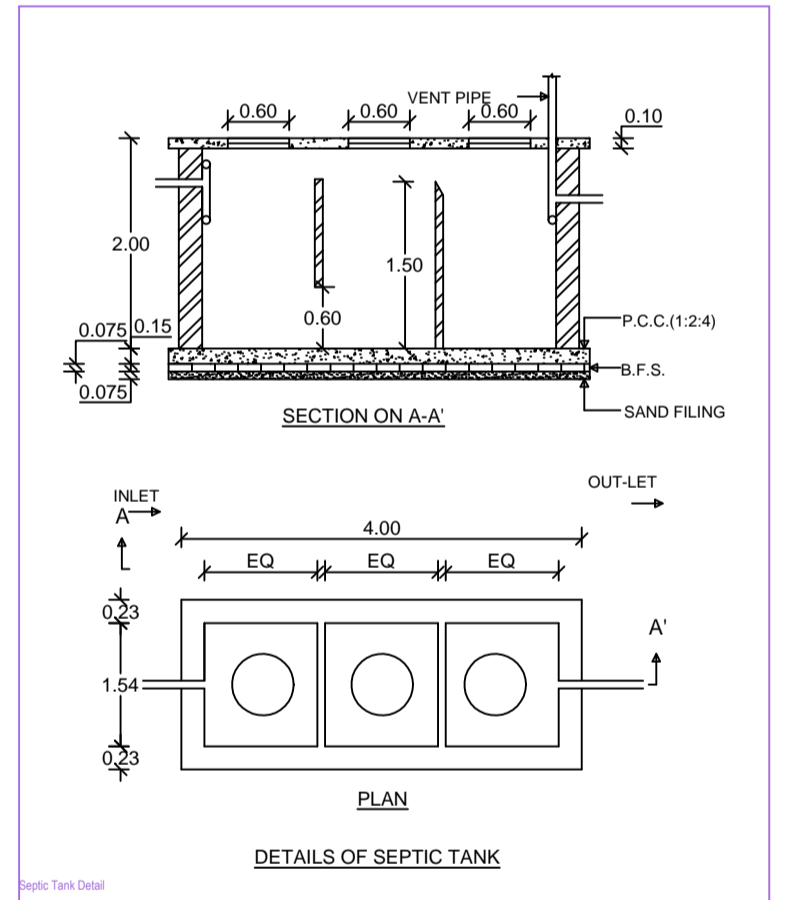
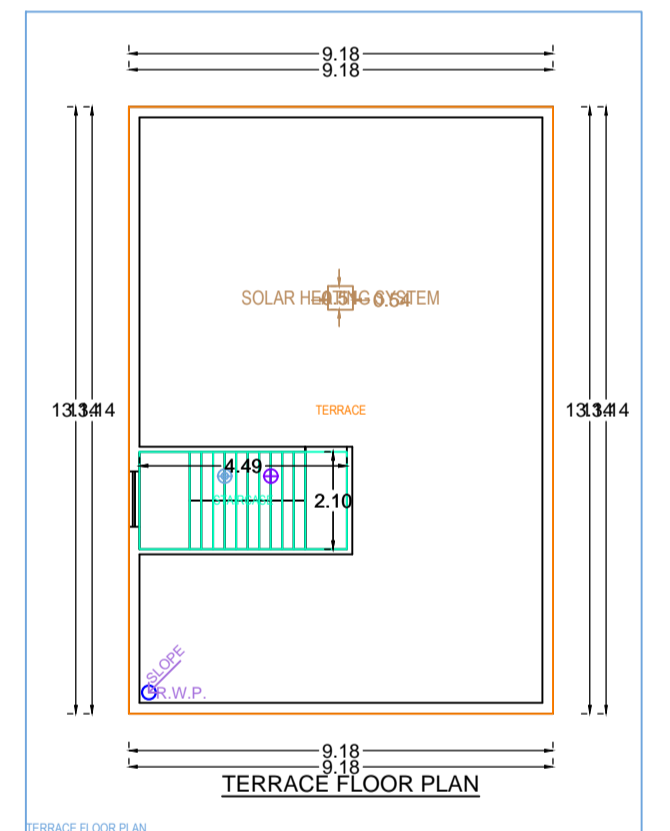
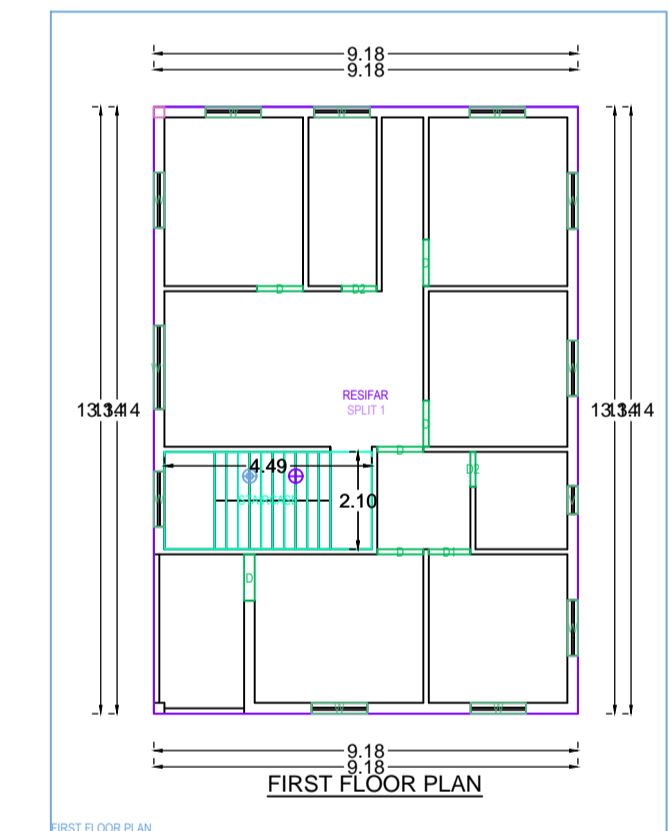
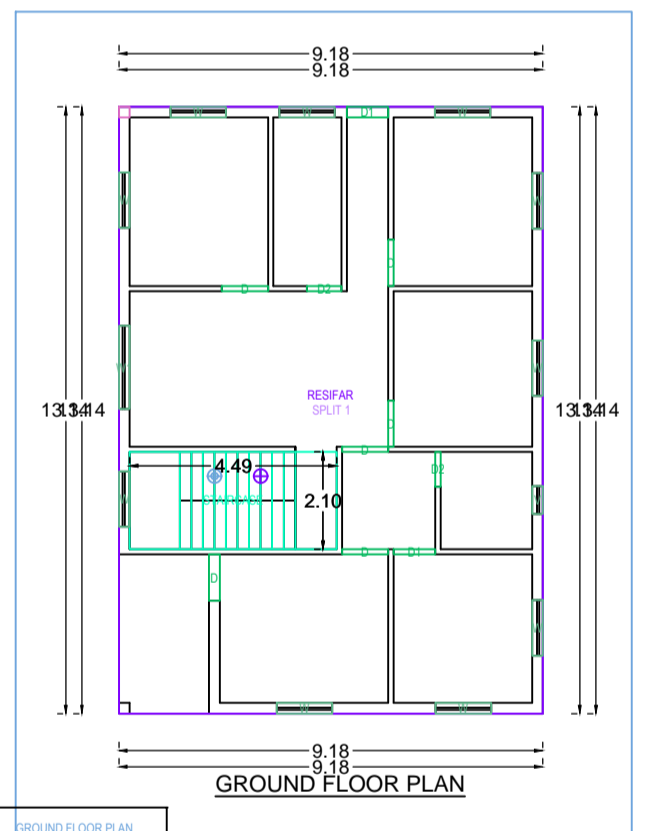
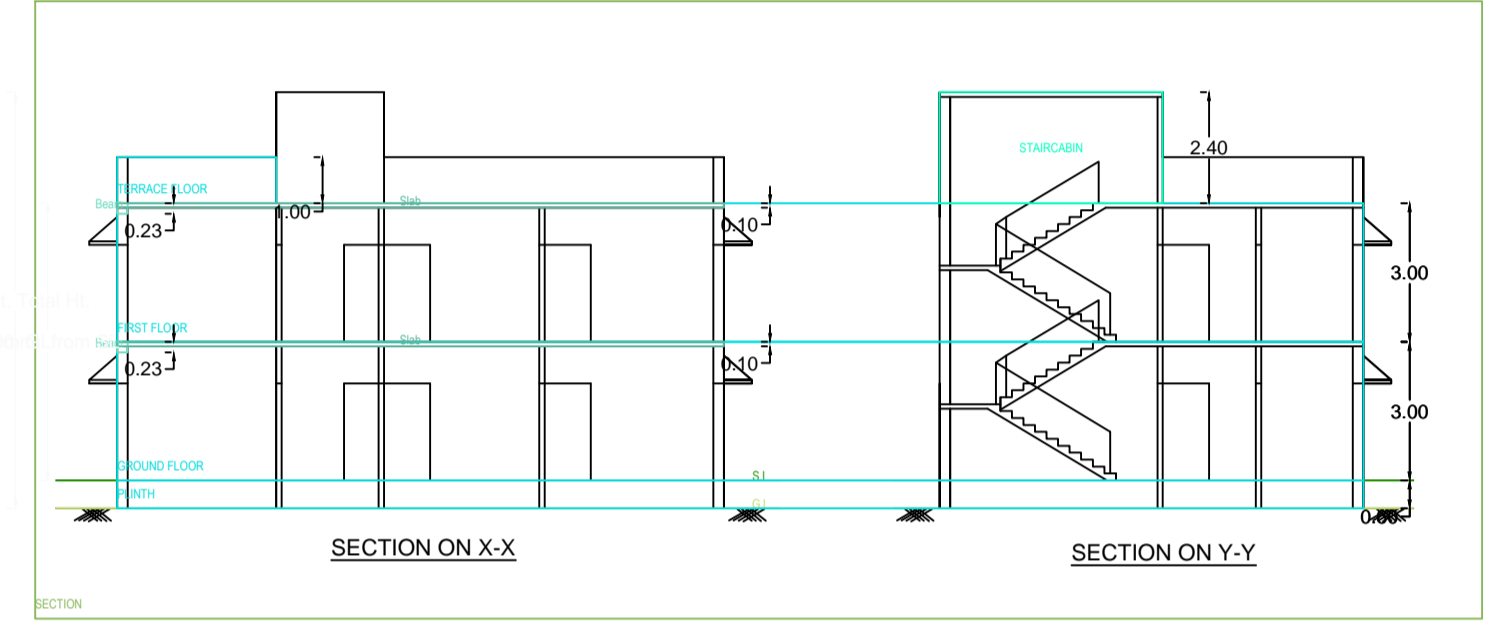
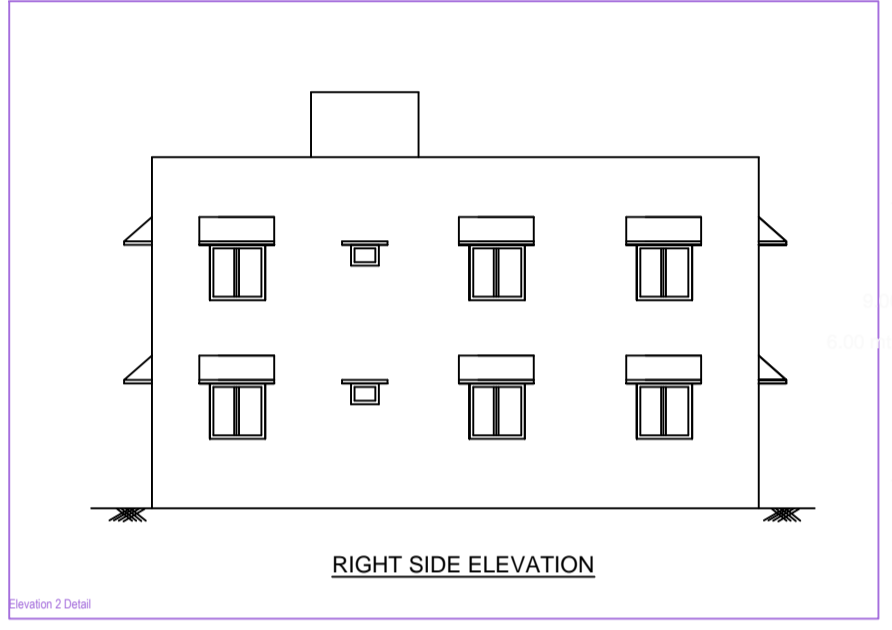
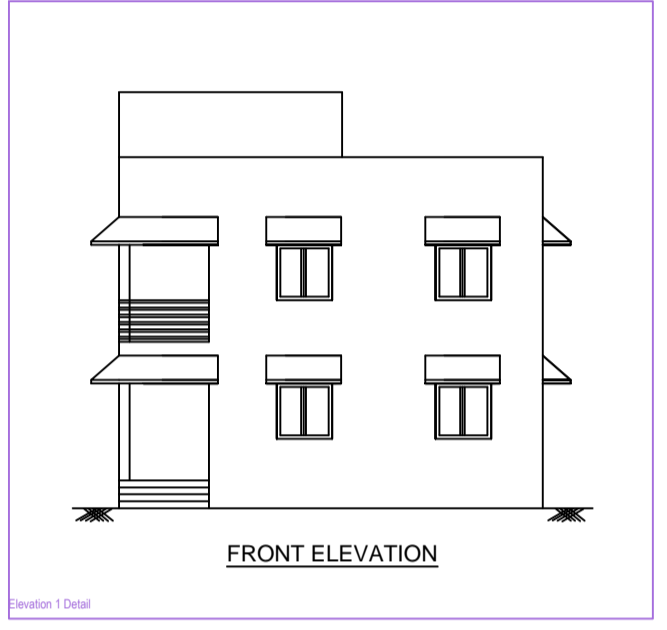
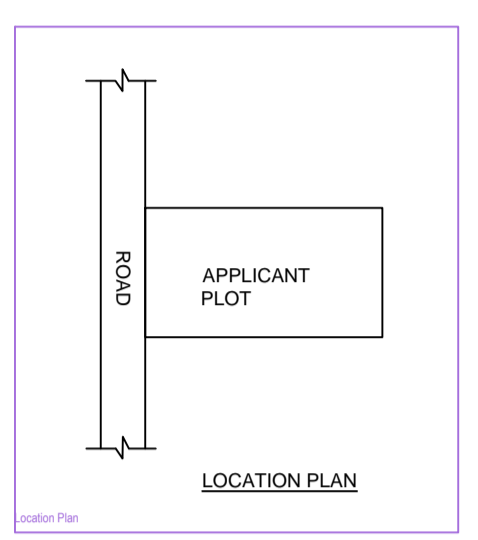
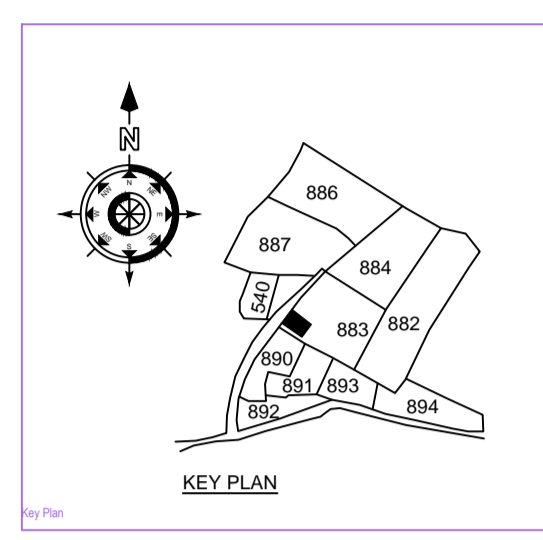
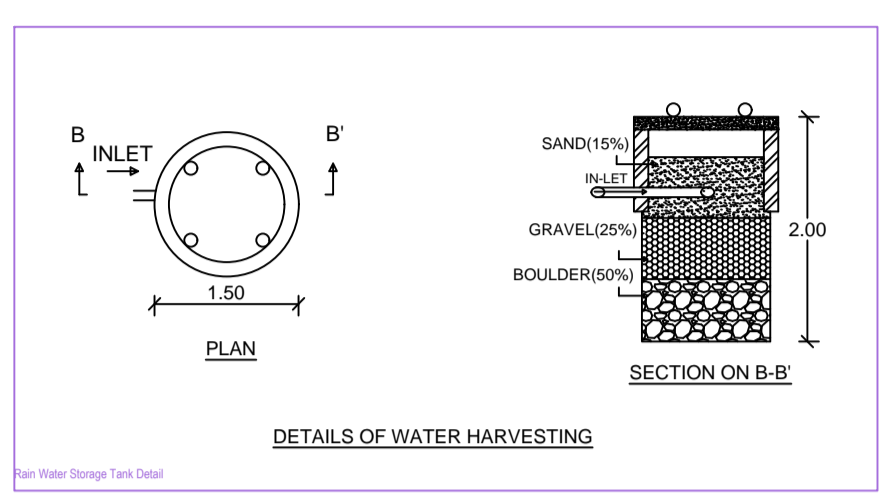
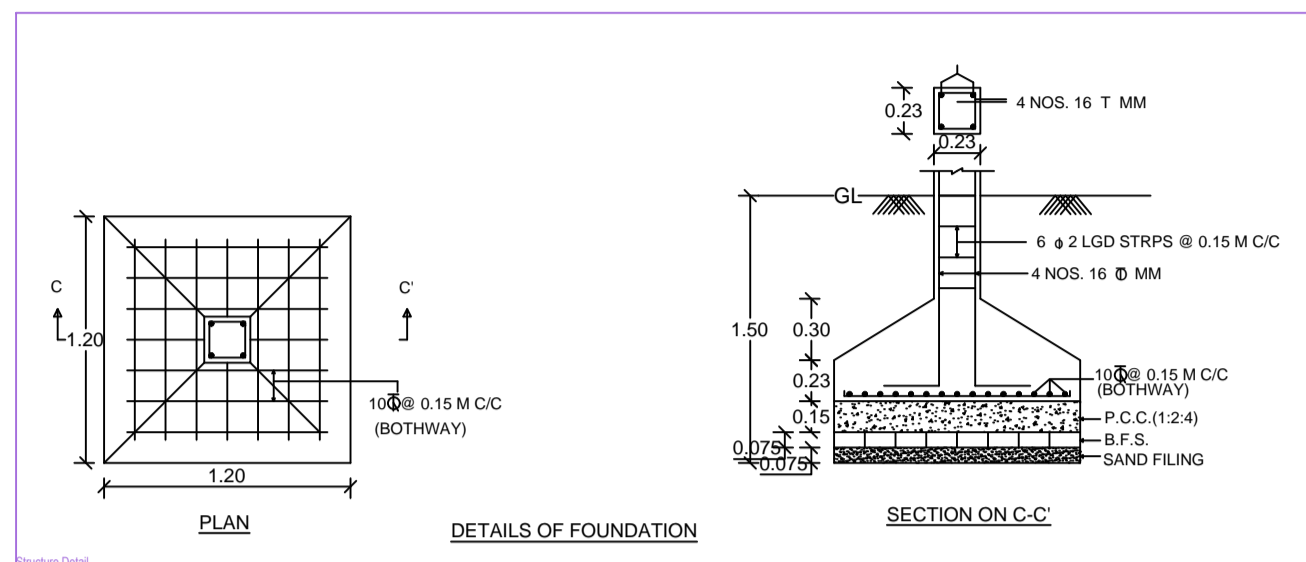

AREA STATEMENT: CHAS MUNICIPAL CORPORATION	VERSION NO. : 1.0/37
PROJECT DETAILS:	VERSION DATE: 16/10/2020
Project No. : -	Plot Use: Residential
Report: TRANSPARENT URBAN LOCAL BODIES	Plot Subcode: Bungalow Dwelling / Non Apartment
District: BOGDOL	Land Use Zone: RA
Application Type: General Proposal	Abutting Road Width: -
Project Type: Building Permission	Plot No.:
Nature of Development: New	Revenue Survey No./Survey No.:
Location: Old Area	Thana No.:
Site Location: RA	Planning No.:
Village/Mouza Name: -	Khata No.:
Ward No.:	North:
Road/Street: -	South:
	East:
	West:

AREA OF PLOT (Sqm)	201.17
Net POC Area (Gross POC Area)	201.17
Deduction from Gross POC Area	28.24
Net POC Area (Net POC Area)	172.94
Proposed FAR	201.17
Proposed Coverage Area (30.00%)	51.88
Total Coverage Area (30.00%)	51.88
Proposed FAR	241.12
Total Coverage Area (30.00%)	241.12
Proposed FAR	241.12
Total Coverage Area (30.00%)	241.12
Proposed FAR	241.12
Total Coverage Area (30.00%)	241.12

Color Index:	Color Index:
Color Index:	Color Index:

Building Name	Road Name	Front Margin	Rear Margin	Side Margin	Setback Margin
A-1 (RESIDENTIAL)	4.57 M ROAD	3.12	1.50	0.90	0.90

Building	No. of Same Bldg	Total Built Up Area (Sq.M)	Proposed FAR Area (Sq.M)	Total FAR Area (Sq.M)	Tent (No.)
A-1 (RESIDENTIAL)	1	241.12	241.12	241.12	01
GRAND TOTAL	1	241.12	241.12	241.12	01

Building A (RESIDENTIAL)				
Floor Name	Total Built Up Area (Sq.M)	Proposed FAR Area (Sq.M)	Total FAR Area (Sq.M)	Tent (No.)
Ground Floor	120.56	120.56	120.56	01
First Floor	120.56	120.56	120.56	00
Terrace Floor	0.00	0.00	0.00	00
Total	241.12	241.12	241.12	01
Total Number of Same Buildings: 1				
Total	241.12	241.12	241.12	01

SCHEDULE OF JOINERY:				
BUILDING NAME	NAME	LENGTH	HEIGHT	NOS
A-1 (RESIDENTIAL)	02	0.75	2.10	04
A-1 (RESIDENTIAL)	03	0.90	2.10	12
A-1 (RESIDENTIAL)	04	1.00	2.10	12
Total	-	-	-	19

SCHEDULE OF JOINERY:				
BUILDING NAME	NAME	LENGTH	HEIGHT	NOS
A-1 (RESIDENTIAL)	07	0.90	1.20	02
A-1 (RESIDENTIAL)	08	1.20	1.20	20
A-1 (RESIDENTIAL)	09	1.00	1.20	12
Total	-	-	-	24

UnitBUA Table for Building -A (RESIDENTIAL)						
FLOOR	Name	UnitBUA Type	UnitBUA Area	Carpet Area	No. of Rooms	No. of Tenement
GROUND FLOOR	SPLIT 1	FLAT	241.11	241.01	11	1
Total	-	-	241.11	241.01	22	1