

SITE PLAN
SCALE :-1IN=200
SITE PLAN

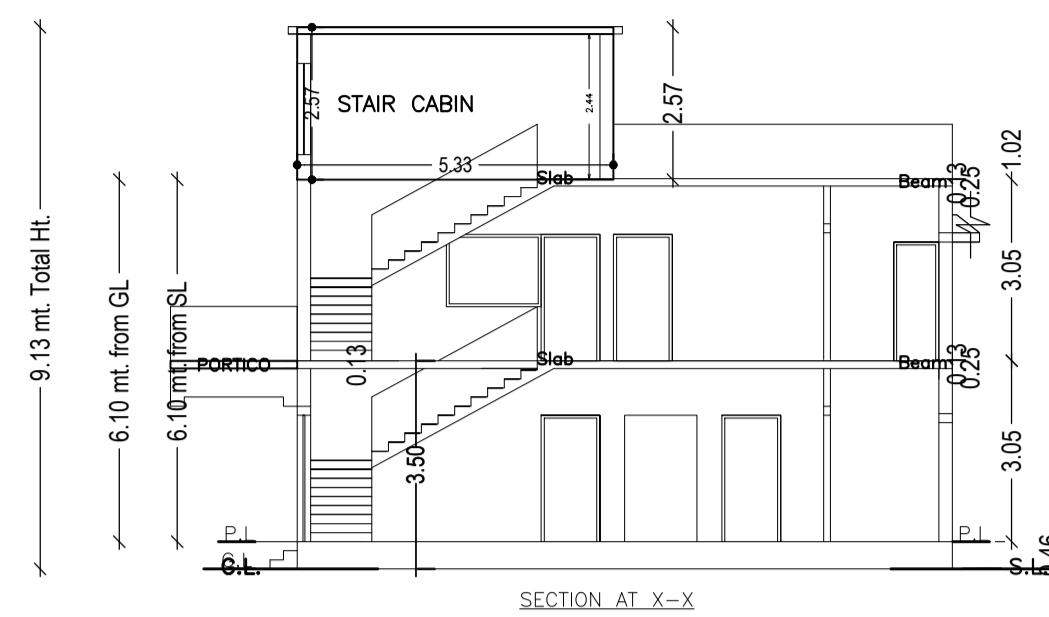

SECTION AT X-X

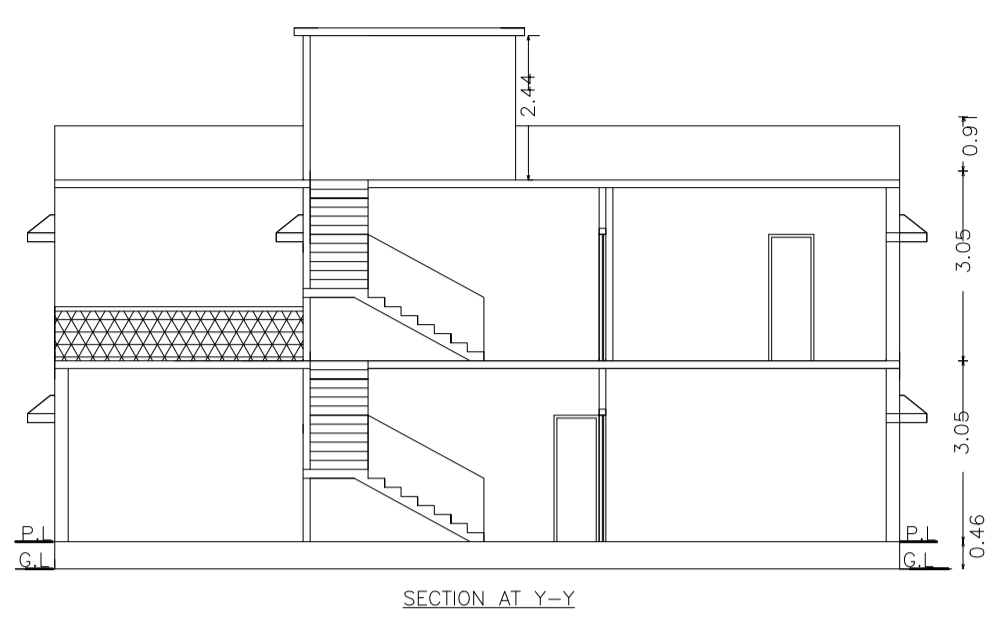

SECTION AT Y-Y

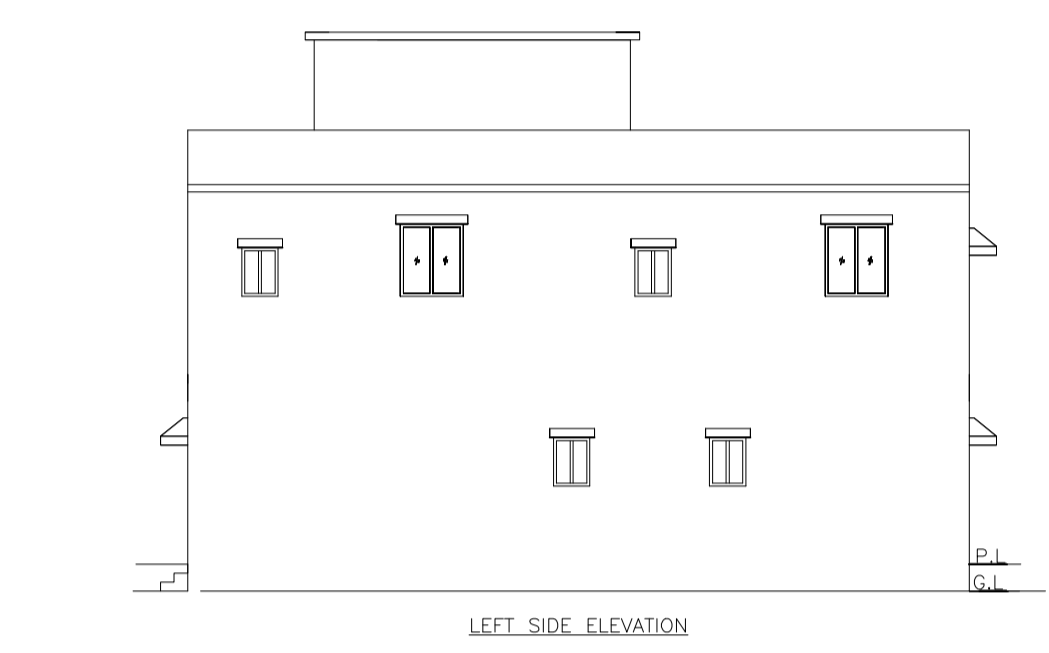

LEFT SIDE ELEVATION

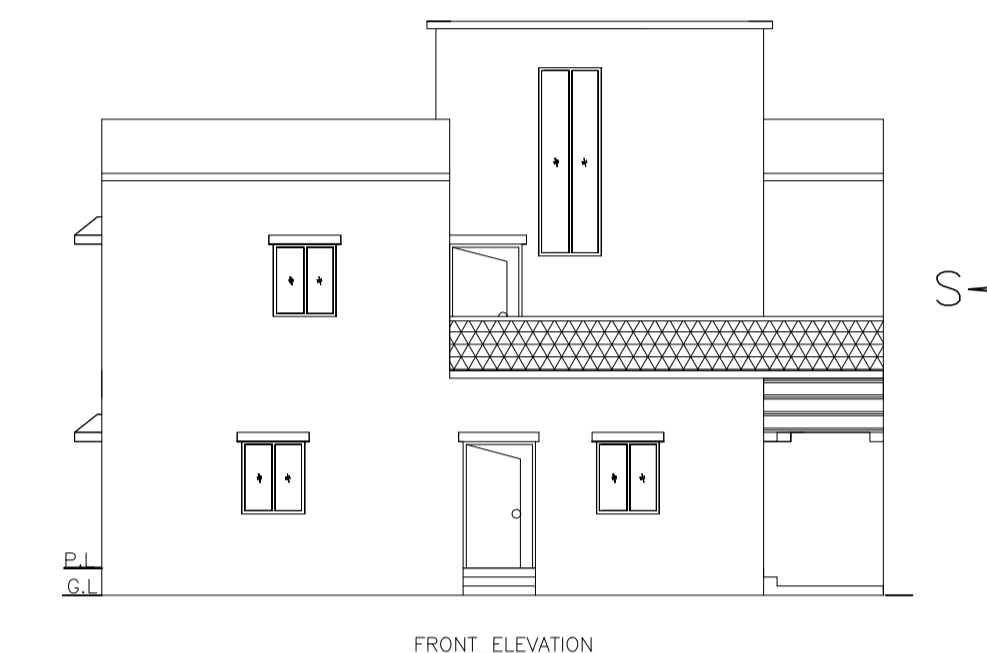

FRONT ELEVATION

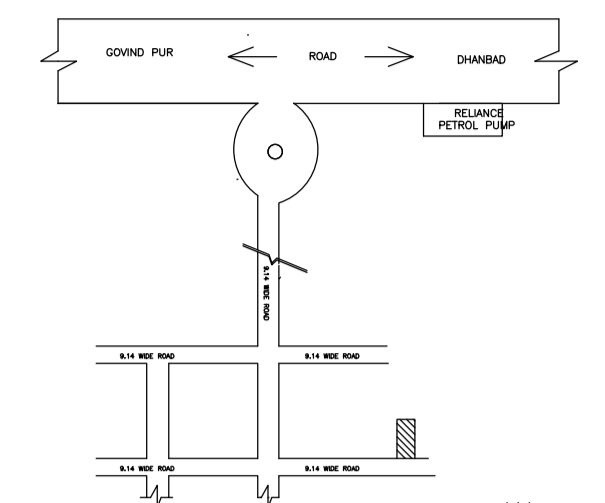

LOCATION PLAN
NOT TO SCALE

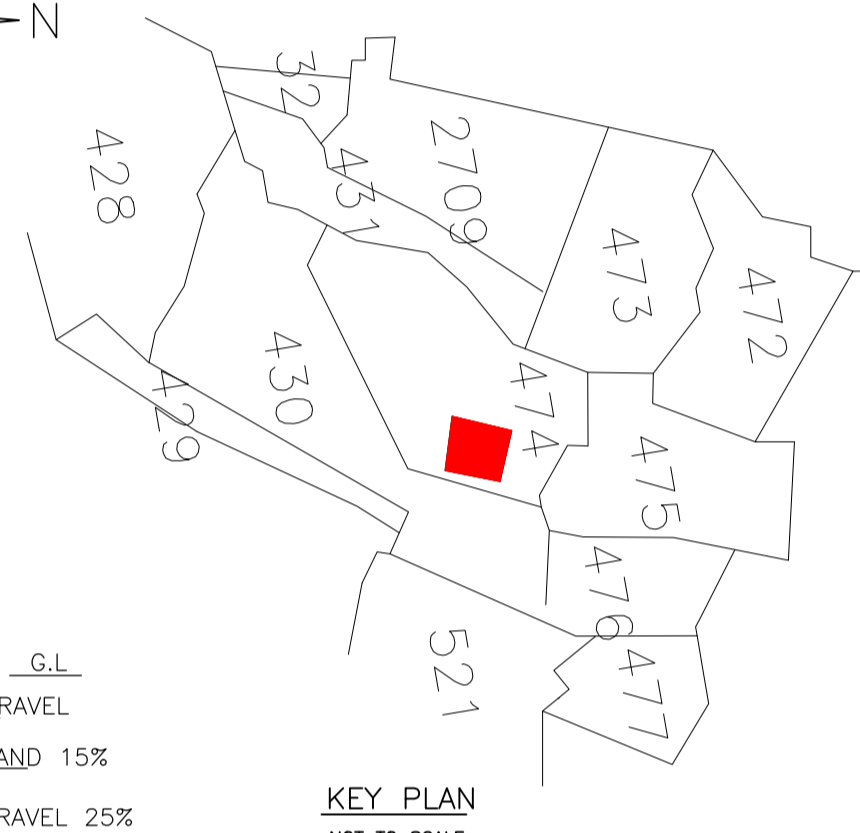

KEY PLAN
NOT TO SCALE

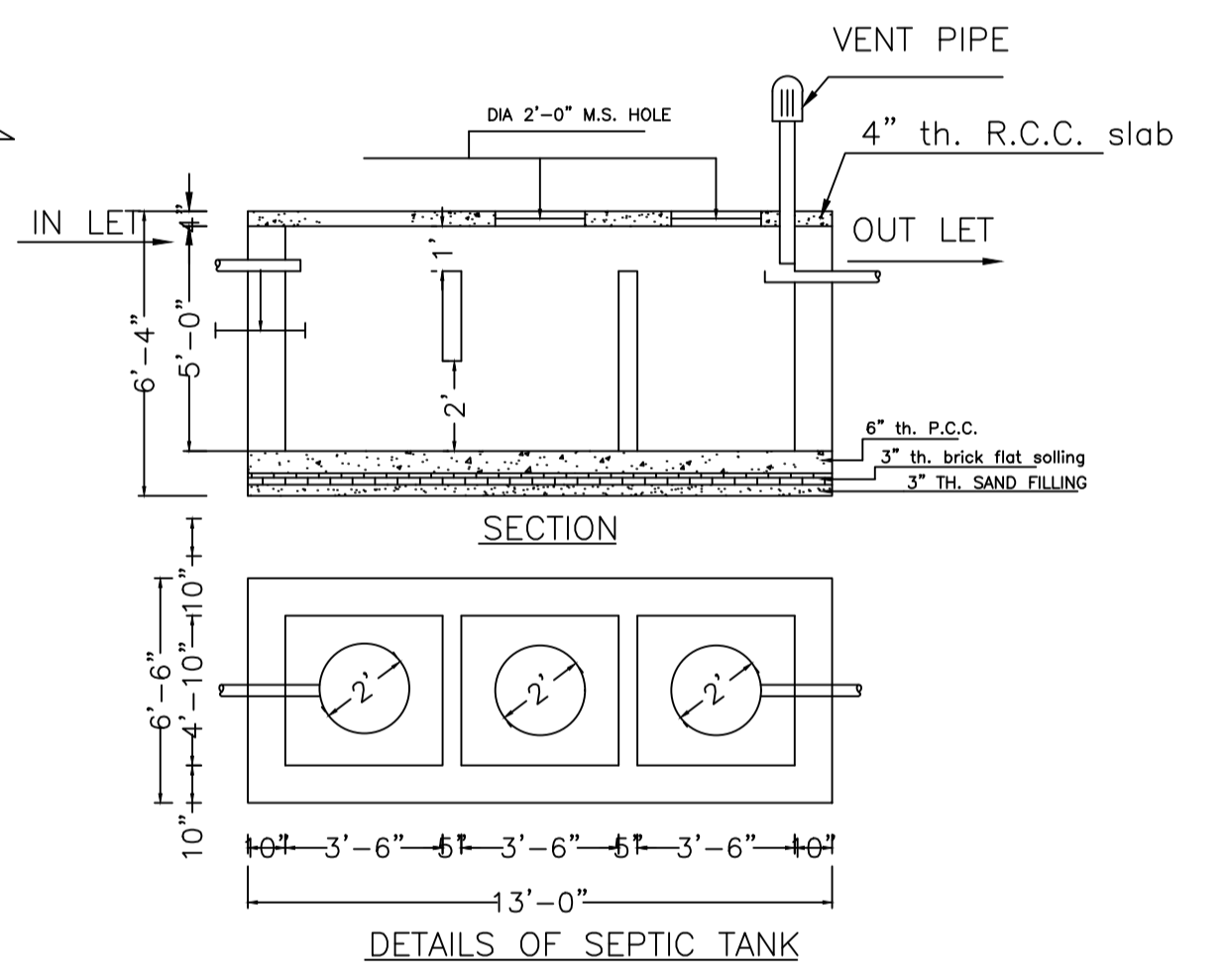

DETAILS OF SEPTIC TANK

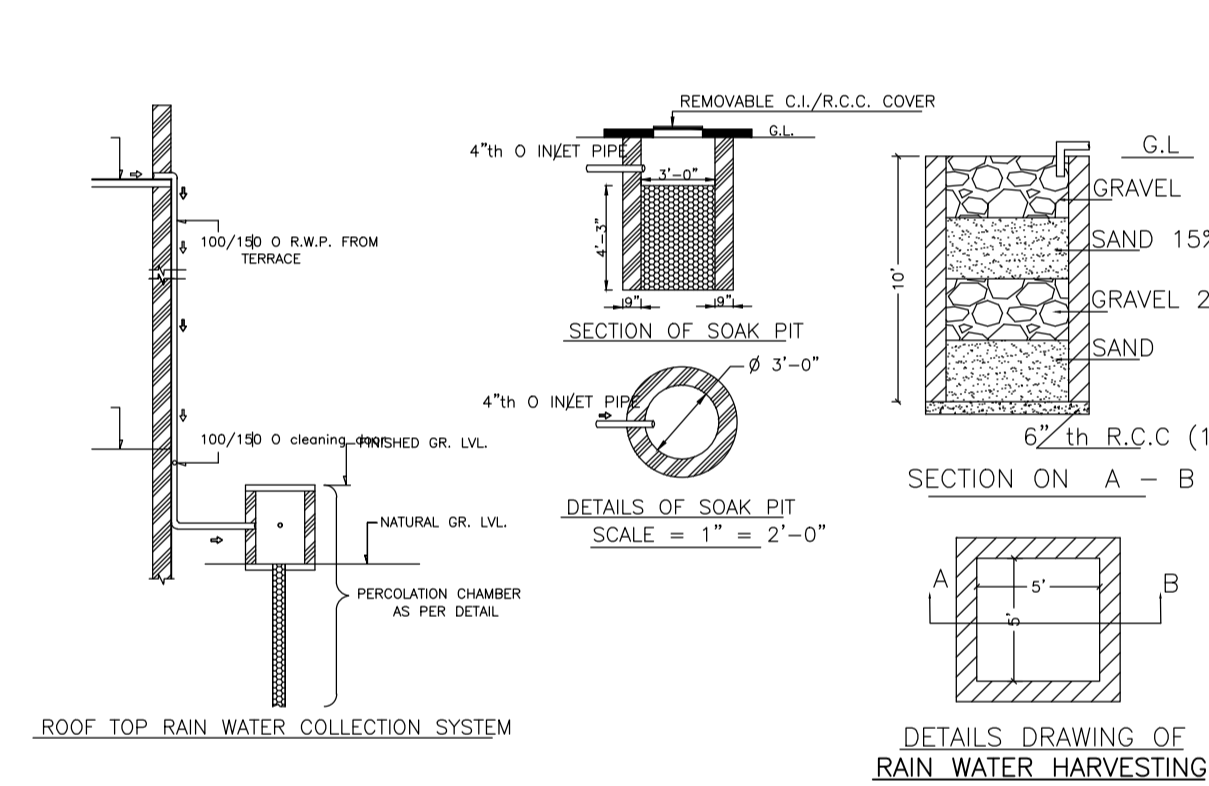

DETAILS DRAWING OF RAIN WATER HARVESTING

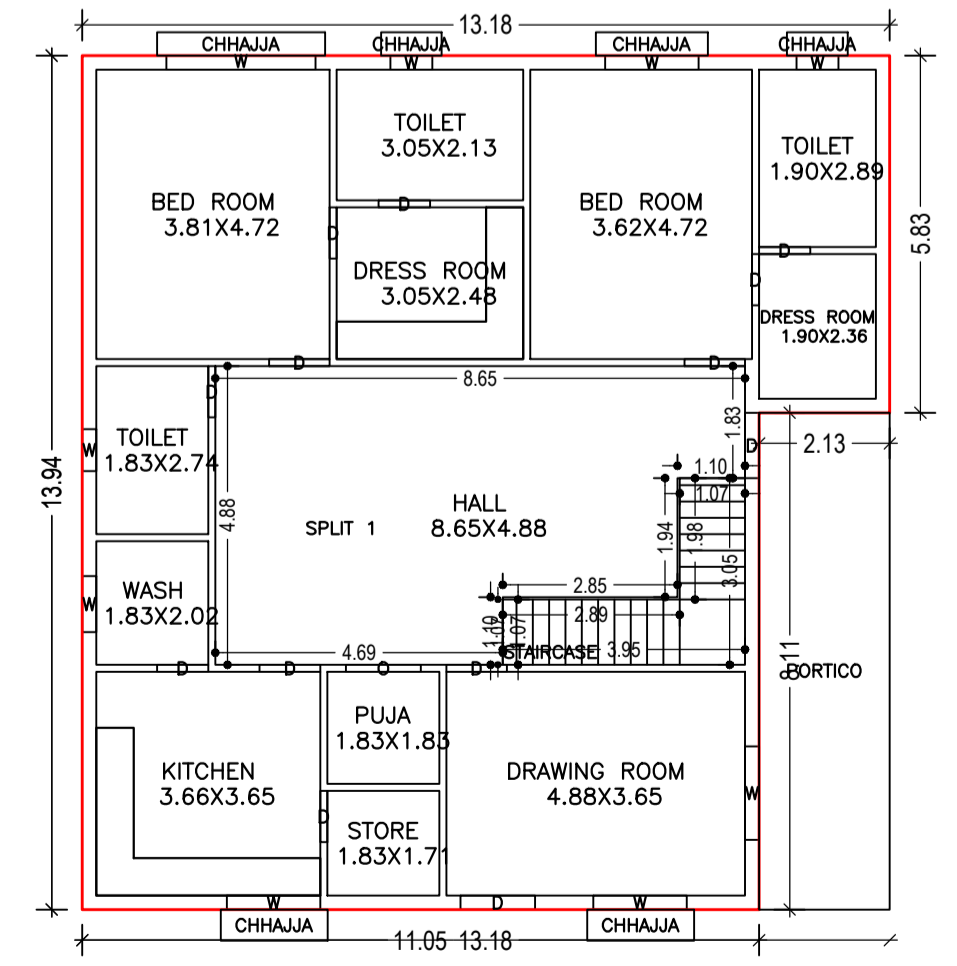

GROUND FLOOR PLAN
(Proposed)
SCALE 1:100

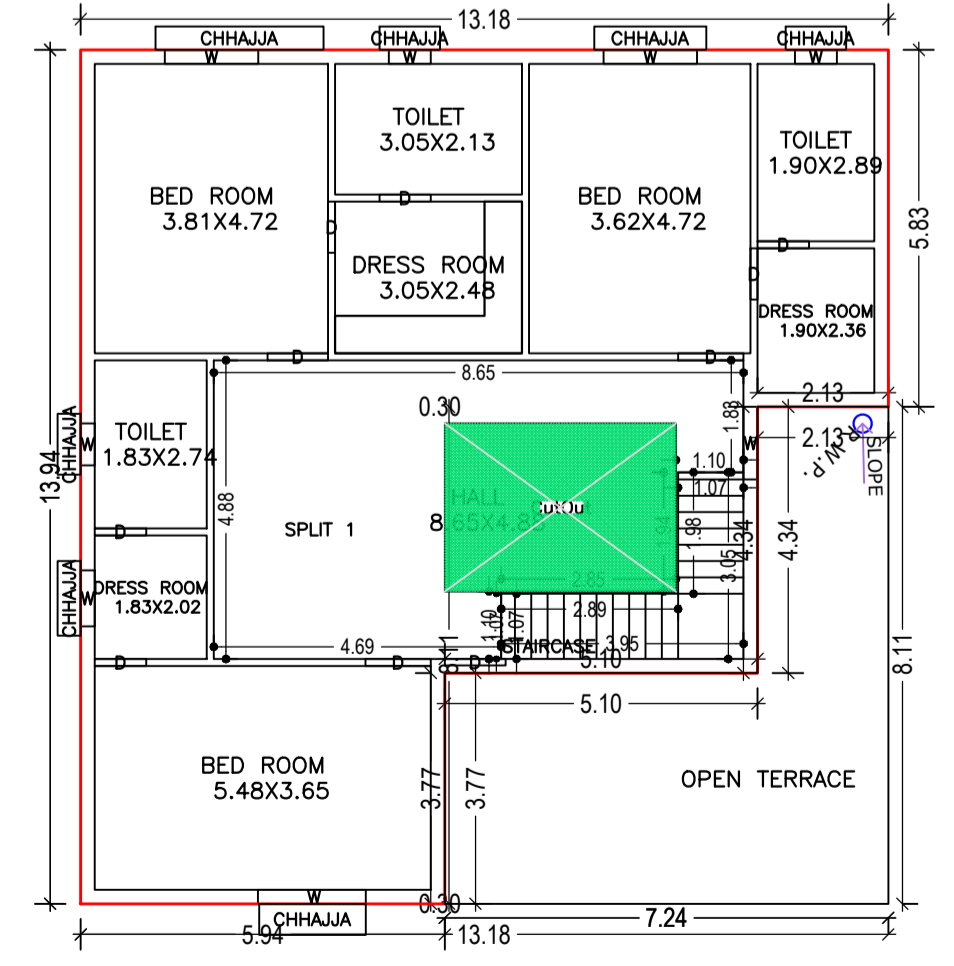

FIRST FLOOR PLAN
(Proposed)
SCALE 1:100

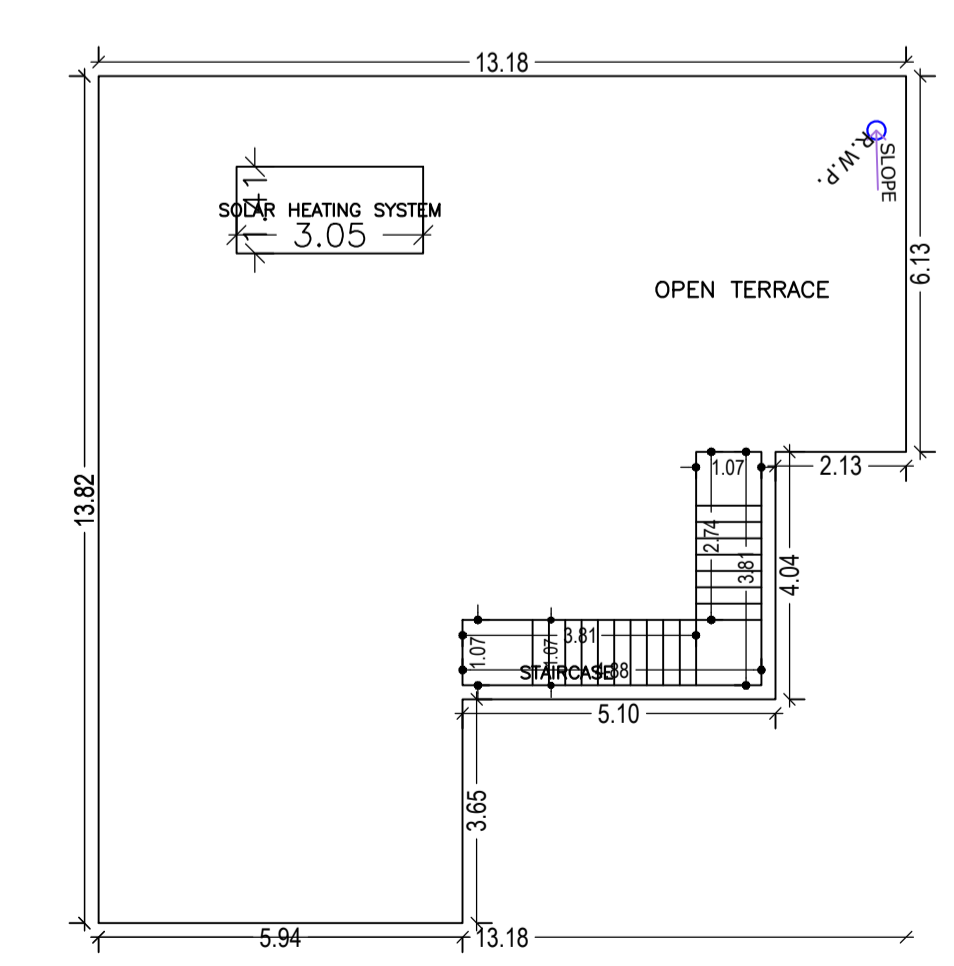

TERRACE FLOOR PLAN
(Proposed)
SCALE 1:100

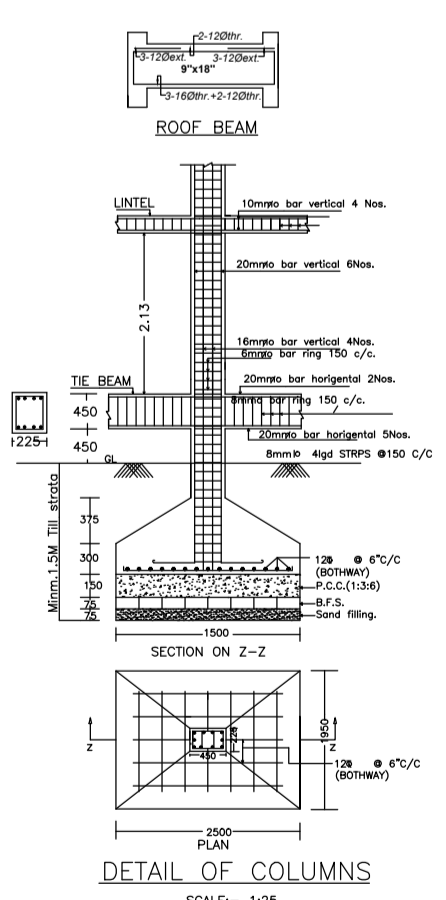

DETAIL OF COLUMNS
SCALE=1:20

Building :RESI (MANISH)

Floor Name	Gross Builtup Area	Deductions From Gross BUA/Area in Sq.mt.	Total Built Up Area (Sq.mt.)	Deductions (Area in Sq.mt.) Archi.Proj	Proposed FAR Area (Sq.mt.)	Total FAR Area (Sq.mt.)	Total Consumed Additional FAR Area (Sq.mt.)	Tnmt (No.)
Ground Floor	183.66	0.00	183.66	17.29	166.37	166.37	166.37	01
First Floor	147.15	10.34	136.81	0.00	136.81	136.81	136.81	00
Terrace Floor	0.00	0.00	0.00	0.00	0.00	0.00	0.00	00
Total :	330.81	10.34	320.47	17.29	303.18	303.18	303.18	01
Total Number of Same Buildings	1							

SCHEDULE OF DOOR:

BUILDING NAME	NAME	LENGTH	HEIGHT	NOS
RESI (MANISH)	D	0.84	2.10	13
RESI (MANISH)	D	0.99	2.10	06
RESI (MANISH)	D	1.07	2.10	03
RESI (MANISH)	O	1.22	2.10	01
RESI (MANISH)	D	1.22	2.10	01

SCHEDULE OF WINDOW/VENTILATION:

BUILDING NAME	NAME	LENGTH	HEIGHT	NOS
RESI (MANISH)	W	0.69	1.20	06
RESI (MANISH)	W	0.91	1.20	02
RESI (MANISH)	W	1.18	1.20	01
RESI (MANISH)	W	1.52	1.20	06
RESI (MANISH)	W	1.76	1.20	01
RESI (MANISH)	W	2.44	1.20	01

UnitBUA Table for Building :RESI (MANISH)

FLOOR	Name	UnitBUA Type	UnitBUA Area	Carpet Area	No. of Rooms	No. of Tenement
GROUND FLOOR PLAN	SPLIT 1	FLAT	303.17	293.66	13	1
FIRST FLOOR PLAN	SPLIT 1	FLAT	0.00	0.00	10	0
Total:	-	-	303.17	293.66	23	1

LTP NAME AND SIGNATURE	STRUCTURAL ENG'S NAME AND SIGNATURE	BUILDER NAME AND SIGNATURE	DIGITAL SIGNATURE
ANIL KUMAR CHAUDHARY MADA/ENG/0005/2019			

Proposal Basic Information

Proposal File No.	MADA/BP/0447/2023
Owner Name	SRI.MANISH KUMAR
Khata No	74 (OLD),220 (NEW)
Plot No	617 (OLD),474 (NEW)
Village Name	Amaghata
Use	Residential
SubUse	Bungalow/ Dwelling / Non Apartment

AREA STATEMENT MINERAL AREA DEVELOPMENT AUTHORITY

AREA DETAILS:	Area	SQ.MT.
AREA OF PLOT (Minimum)	(A)	278.41
NET AREA OF PLOT(Gross Plot Area - Deduction from Gross Plot area)	(A-Deductions)	278.41
Deduction for Balance Plot Area(from Gross Plot Area)		
Common Plot		21.22
Total		21.22
BALANCE AREA OF PLOT(Net Plot Area - Recreational/Amenity space)	(A-Deductions)	257.19
PLOT AREA FOR COVERAGE(Net Plot Area)	(A-Deductions)	278.41
Plot Area for FAR (Net Plot Area + Road Widening Area)	(A-Deductions)	278.41
COVERAGE CHECK		
Permissible Coverage area (60.00 %)		167.05
Proposed Coverage Area (59.76 %)		166.37
Total Prop. Coverage Area (59.76 %)		166.37
Balance coverage area (0.24 %)		0.68
FAR CHECK		
Perm. FAR Area (2.500)		696.03
Total Perm. FAR area		696.03
Residential FAR		303.17
Proposed FAR Area		303.17
Total Proposed FAR Area		303.17
Consumed FAR (Factor)		1.09
Balance FAR Area		392.86
BUILT UP AREA CHECK		
Total Proposed BuiltUp Area		320.47
ARCHITECT (Regd)		ANIL KUMAR CHAUDHARY
ENGINEER (Regd)		
SUPERVISOR (Regd)		
OWNER (Regd)		SRI.MANISH KUMAR
DEVELOPMENT AUTHORITY		LOCAL BODY

COLOR INDEX

PLOT BOUNDARY	Black
ABUTTING ROAD	Red
PROPOSED CONSTRUCTION	Green
COMMON PLOT	Yellow
ROAD WIDENING AREA	Blue
EXISTING (To be retained)	White
EXISTING (To be demolished)	Grey

Buildingwise Floor FAR Details

Floor Name	Building Name		Total	
	Proposed Built Up Area (Sq.mt.)	Proposed FAR Area (Sq.mt.)	Total Proposed Built Up Area (Sq.mt.)	Total FAR Area (Sq.mt.)
Ground Floor	183.66	166.37	183.66	166.37
First Floor	136.81	136.81	136.81	136.81
Terrace Floor	0.00	0.00	0.00	0.00
Total :	320.47	303.18	320.47	303.18

Building USE/SUBUSE Details

Building Name	Building Use	Building SubUse	Building Structure
RESI (MANISH)	Residential	Bungalow/ Dwelling / Non Apartment	Non-Highrise

FAR & Tenement Details (Table 4c-1)

Building	No. of Same Bldg	Gross Built Up Area (Sq.mt.)	Deductions From Gross BUA/Area in Sq.mt. Cutout	Total Built Up Area (Sq.mt.)	Deductions (Area in Sq.mt.) Archi.Proj.	Proposed FAR Area (Sq.mt.)	Total FAR Area (Sq.mt.)	Total Consumed Additional FAR Area (Sq.mt.)	Tnmt (No.)
RESI (MANISH)	1	330.81	10.34	320.47	17.29	303.18	303.18	303.18	01
Grand Total :	1	330.81	10.34	320.47	17.29	303.18	303.18	303.18	01