

Project Title : SMT SUPRIYA BISWAS

FOR MADA USE

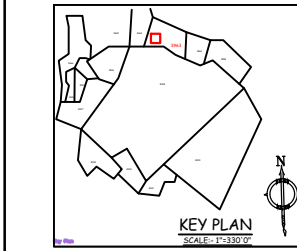

TITLE OF DRAWING

PROPOSED PLAN FOR, SMT. SUPRIYA BISWAS D/O MANIK CHANDRA ROY W/O SRI. DILIP KUMAR BISWAS, AT PRESENT RESIDING AT, QTR NO J-15 ADARSH NAGARI, PO, MALKERA, PS, KATRAS, DIST. DHANBAD, JHARKHAND.
FOR RESIDENTIAL BUILDING AT, OLD KHATA NO- 55, NEW KHATA NO - 219, OLD C.S. PLOT NO- 2527, NEW C.S PLOT NO - 3963, AREA- 2.75 DECIMAL, SITUATED AT MAUZA NO:86, MAUZA -BARAPICHRRI (GOVINDPUR), DISTRICT-DHANBAD (JHARKHAND)

BRIEF SPECIFICATION

FOUNDATION----- CEMENT CONCRETE (1:3:6)
FOOTING----- R.C.C. (1:1½:3)
BRICK WORK IN FOUNDATION & SUPERSTRUCTURE
FIRST CLASS BRICK WORK IN CEMENT MORTAR (1:4)
D.P.C-----1" D.P.C. IN CEMENT CONCRETE (1:2:4)
COLUMNS----- R.C.C. (1:1½:3)
BEAM----- R.C.C. (1:1½:3)
FLOOR----- 4" I.P.S. OVER 3" P.C.C.
ROOF----- 4" THK R.C.C. ROOF (1:1½:3)
LINTEL----- 4" THK R.C.C. LINTEL (1:1½:3)
STAIRS----- RESE- 6", TREAD- 10"
DOORS----- D-3'3"X7'0", D1-3'0"X7'0", D2-2'6"X7'0"
WINDOWS----- W-5'0"X4'0", W1-4'0"X4'0", W2-2'6"X4'0"
VENTS----- V-2'0"X2'0"

SCHEDULE

D - 3'-6" X 7'-0" W - 4'-0" X 4'-0"
D1 - 3'-0" X 7'-0" W1 - 3'-0" X 4'-0"
D2 - 2'-6" X 7'-0" V - 2'-0" X 2'-0"

DETAILS OF AREA

LAND AREA : 1200 Sft.
GROUND FLOOR AREA : 665.00 Sft.
FIRST FLOOR AREA : 665.00 Sft.
COVERED AREA : 1330.00 Sft.
% OF PLINTH AREA : 55.42 %
F.A.R : 1.10

SIGN OF OWNER

SIGN OF ARCHITECT

ARCH SANJAY KUMAR

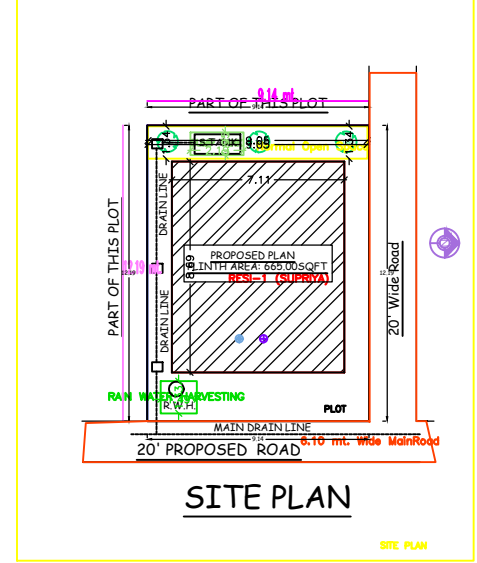
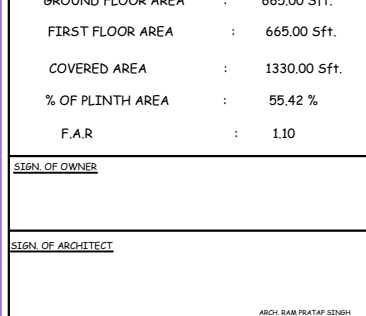
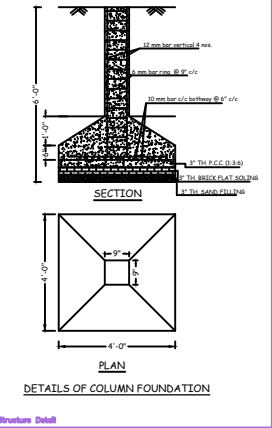
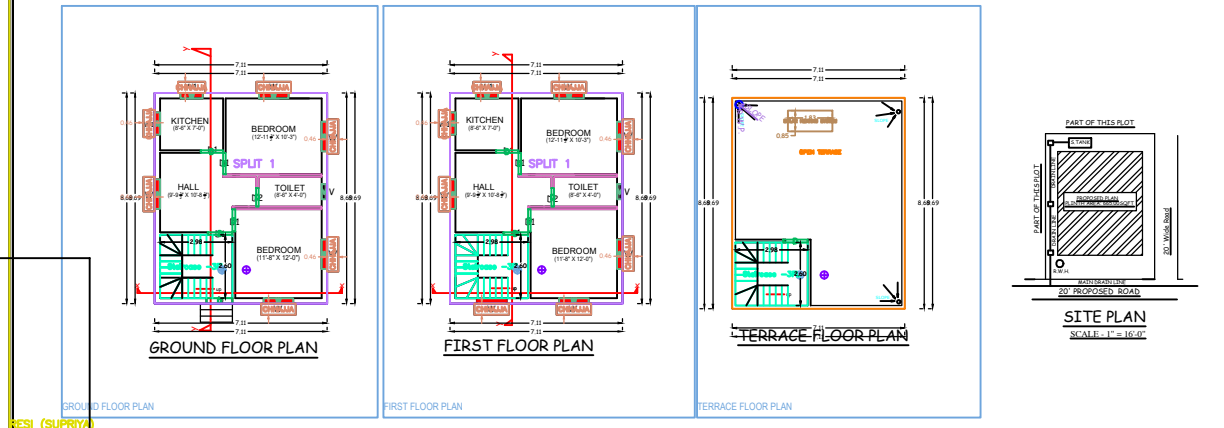
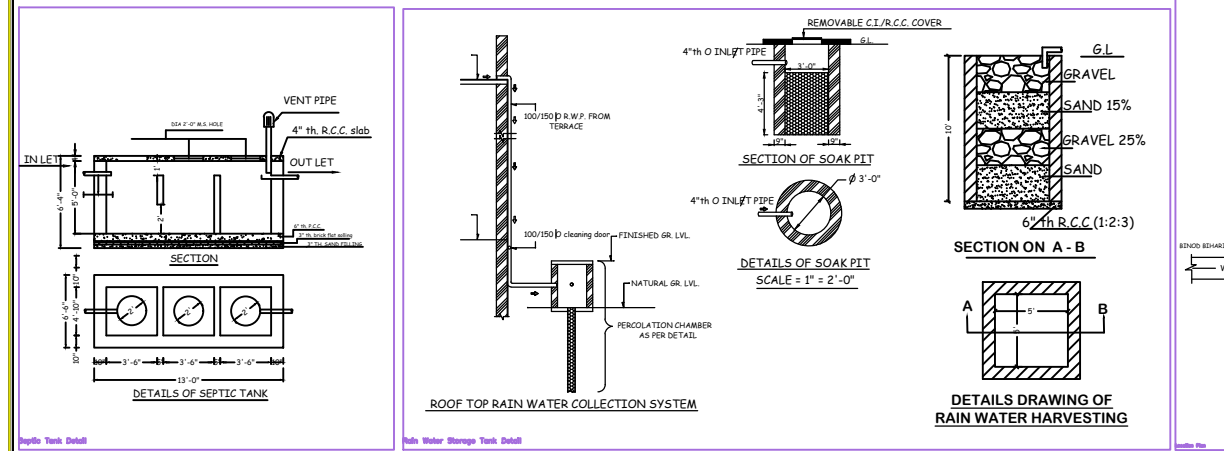
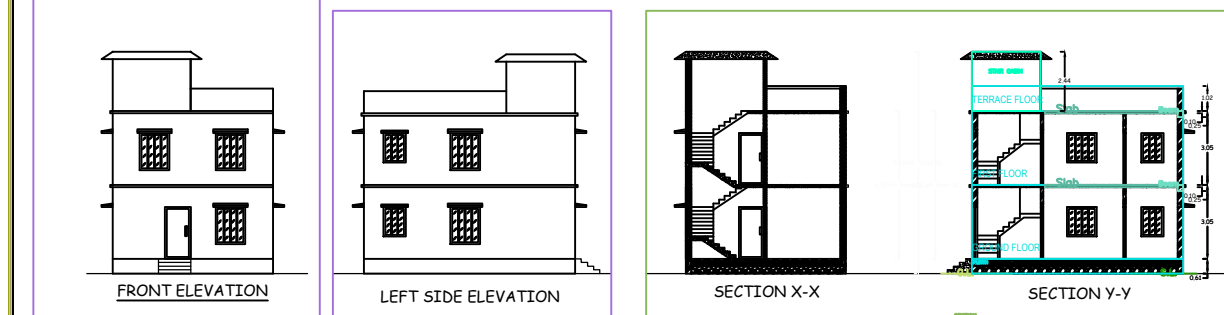

AREA STATEMENT MINERAL AREA DEVELOPMENT		VERSION NO. 1.0.30			
PROJECT DETAILS		VERSION DATE: 05/03/2024			
Project No.	Plot Use: Residential				
Project Name: BARABANDI URBAN LOCAL TRACKS	Plot No.:				
Project: DHANBAD	Land Use Zone: RA				
Application Type: General Proposal	Abutting Road Width: -				
Project Type: Building Permission	Plot No.:				
Nature of Development: New	Revenue Survey No/Survey No: -				
Location: Plot Area	Thana No.:				
City/Block: RA	Plotting No.:				
Village/Muza Name:	Khata No.:				
Area No.:	Block No.:				
Section No.:	East -				
Sub-section No.:	West -				
Area Details		sq. mtr			
AREA OF PLOT (Minimum)	(A)	111.39			
NET PLOT Area (Minimum)	(A-Deductions)	111.39			
Deduction from Gross Plot Area	(A-Deductions)				
Requirements for Minimum Plot Area from Gross Plot Area					
COV Area		12.08			
Net Area		12.08			
Minimum Plot Area (Net Plot Area - Deductions/Minutely equal)	(A-Deductions)	99.30			
Plot Area for Coverage (Net Plot Area - Deductions)	(A-Deductions)	111.39			
Plot Area for FAR (Net Plot Area - Deductions)	(A-Deductions)	111.39			
Minimum Coverage Area (10.44 %)		11.58			
Minimum Coverage Area (10.44 %)		11.58			
FAR CHECK		123.52			
Proposed Area of FAR		123.52			
Total Area of FAR		123.52			
NET UP AREA CHECK		123.52			
NET UP AREA CHECK		123.52			
NET UP AREA CHECK (Sqm)		123.52			
NET UP AREA CHECK (Sqm)		123.52			
DEVELOPMENT AUTHORITY		LOCAL BODY			
COLOR INDEX					
PLINTH BOUNDARY		Black			
ABUTTING ROAD		Red			
PROPOSED WORK (COVERAGE AREA)		Green			
EXISTING (To be retained)		Blue			
EXISTING (To be demolished)		Yellow			
MARGIN DETAIL					
Building Width	Road Name	Front Margin	Rear Margin	Side Margin	Setback Margin
RESI (SUPRIYA)	6.10 mt. Wide	2.01	1.00	1.01	1.02
FAR & Termentment Details (Table 4c-1)					
Building	No. of Same Bldg.	Total Built Up Area (Sq.m)	Proposed FAR Area (Sq.m)	Total FAR Area (Sq.m)	Total (No.)
RESI (SUPRIYA)	1	123.52	123.52	123.52	01
Grand Total	1	123.52	123.52	123.52	01

Building: RESI (SUPRIYA)

Floor Name	Total Built Up Area (Sq. mt.)	Proposed FAR Area (Sq.m)	Total FAR Area (Sq. mt.)	Total (No.)
ROOF FLOOR	81.76	81.76	81.76	01
GROUND FLOOR	665.00	665.00	665.00	01
FIRST FLOOR	665.00	665.00	665.00	01
TERACE FLOOR	123.52	123.52	123.52	01
GRAND TOTAL	1235.28	1235.28	1235.28	04

SCHEDULE OF JOINERY:

BUILDING NAME	NAME	LENGTH	HEIGHT	NO.
RESI (SUPRIYA)	D	0.76	2.10	02
RESI (SUPRIYA)	D	0.50	2.10	02
RESI (SUPRIYA)	D	0.91	2.10	04
RESI (SUPRIYA)	D	1.23	2.10	04
RESI (SUPRIYA)	D	1.23	2.10	01
RESI (SUPRIYA)	D	1.23	2.10	12

SCHEDULE OF JOINERY:

BUILDING NAME	NAME	LENGTH	HEIGHT	NO.
RESI (SUPRIYA)	D	0.41	1.20	04
RESI (SUPRIYA)	D	0.41	1.20	04
RESI (SUPRIYA)	W	1.22	1.20	10
RESI (SUPRIYA)	W	1.22	1.20	18

Unit/BUA Table for Building: RESI (SUPRIYA)

FLOOR	Name	Unit/BUA Type	Unit/BUA Area	Carpet Area	No. of Rooms	No. of Terment
GROUND	SPLIT 1	FLAT	123.52	121.66	4	1
ROOF			123.52	121.66	10	1