

Proposal Basic Information

Proposal File No.	MADA/BP/0174/2023
Owner Name	SMT. SATPAL KOUR
Khata No	OLD KHATA NO-74, NEW KHATA NO-189
Plot No	OLD PLOT NO-337, NEW PLOT NO-1160
Village Name	Amaghata
Use	Residential
SubUse	Bungalow/ Dwelling / Non Apartment

AREA STATEMENT MINERAL AREA DEVELOPMENT AUTHORITY	VERSION NO. : 1.0.70 VERSION DATE: 16/10/2020		
PROJECT DETAIL:			
Region: JHARKHAND URBAN LOCAL BODIES	Plot Use: Residential		
District: DHANBAD	Plot SubUse: Bungalow/ Dwelling / Non Apartment		
Authority: MINERAL AREA DEVELOPMENT AUTHORITY	PlotNearby/ReligiousStructure: NA		
Inward No: MADA/BP/0174/2023	Plot/SubPlot No: OLD PLOT NO-337, NEW PLOT NO-1160		
Application Type: General Proposal	North: Plot No. - SAME PLOT		
Project Type: Building Permission	South: Plot No. - SAME PLOT		
Nature of Development: New	East: Road Width - 6.10		
Location of Development Area: Old Area	West: Plot No. - SAME PLOT		
AREA DETAILS:			
AREA OF PLOT (Minimum)	(A)	SQ.MT.	161.12
NET AREA OF PLOT(Gross Plot Area - Deduction from Gross Plot area)	(A-Deductions)		161.12
Deduction for Balance Plot Area(from Gross Plot Area)			
Total			11.76
BALANCE AREA OF PLOT(Net Plot Area - Recreational/Amenity space)	(A-Deductions)		149.35
PLOT AREA FOR COVERAGE(Net Plot Area)	(A-Deductions)		161.12
Plot Area for FAR (Net Plot Area + RoadWidening Area)	(A-Deductions)		161.12
COVERAGE CHECK			
Permissible Coverage area (70.00 %)			112.78
Proposed Coverage Area (57.67 %)			92.92
Total Prop. Coverage Area (57.67 %)			92.92
Balance coverage area (12.33 %)			19.86
FAR CHECK			
Perm. FAR Area (2.500)			402.80
Total Perm. FAR area			402.80
Residential FAR			176.01
Proposed FAR Area			176.01
Total Proposed FAR Area			176.01
Consumed FAR (Factor)			1.09
Balance FAR Area			226.79
BUILT UP AREA CHECK			
Total Proposed BuiltUp Area			176.01
ARCHITECT (Regd)			RAM PRATAP SINGH
ENGINEER (Regd)			
SUPERVISOR (Regd)			
OWNER (Regd)			SMT. SATPAL KOUR
DEVELOPMENT AUTHORITY		LOCAL BODY	

COLOR INDEX	
PLOT BOUNDARY	Black
ABUTTING ROAD	Red
PROPOSED CONSTRUCTION	Green
COMMON PLOT	Yellow
ROAD WIDENING AREA	Blue
EXISTING (To be retained)	White
EXISTING (To be demolished)	Grey

Buildingwise Floor FAR Details				
Floor Name	Building Name		Total	
	Proposed Built Up Area (Sq.mt.)	Proposed FAR Area (Sq.mt.)	Total Proposed Built Up Area (Sq.mt.)	Total FAR Area (Sq.mt.)
Ground Floor	92.92	92.92	92.92	92.92
First Floor	83.09	83.09	83.09	83.09
Terrace Floor	0.00	0.00	0.00	0.00
Total :	176.01	176.01	176.01	176.01

Building USE/SUBUSE Details			
Building Name	Building Use	Building SubUse	Building Structure
A (SATPAL KOUR)	Residential	Bungalow/ Dwelling / Non Apartment	Non-Highrise

FAR & Tenement Details (Table 4c-1)						
Building	No. of Same Bldg	Total Built Up Area (Sq.mt.)	Proposed FAR Area (Sq.mt.)	Total FAR Area (Sq.mt.)	Total Consumed Additional FAR Area (Sq.mt.)	Tnmt (No.)
A (SATPAL KOUR)	1	176.01	176.01	176.01	176.01	01
Grand Total :	1	176.01	176.01	176.01	176.01	01

LTP NAME AND SIGNATURE	STRUCTURAL ENG'S NAME AND SIGNATURE	BUILDER NAME AND SIGNATURE	DIGITAL SIGNATURE
RAM PRATAP SINGH MADA/ARC/0024/2019			

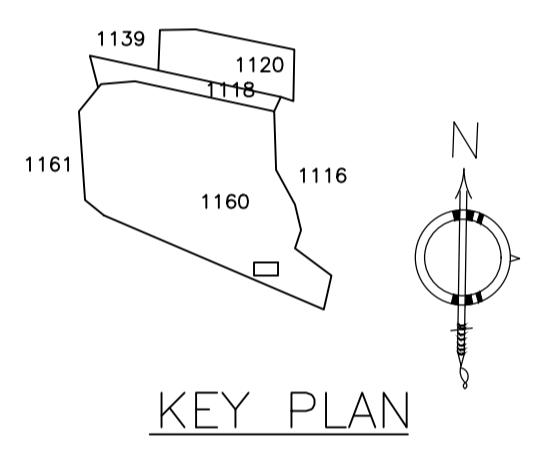
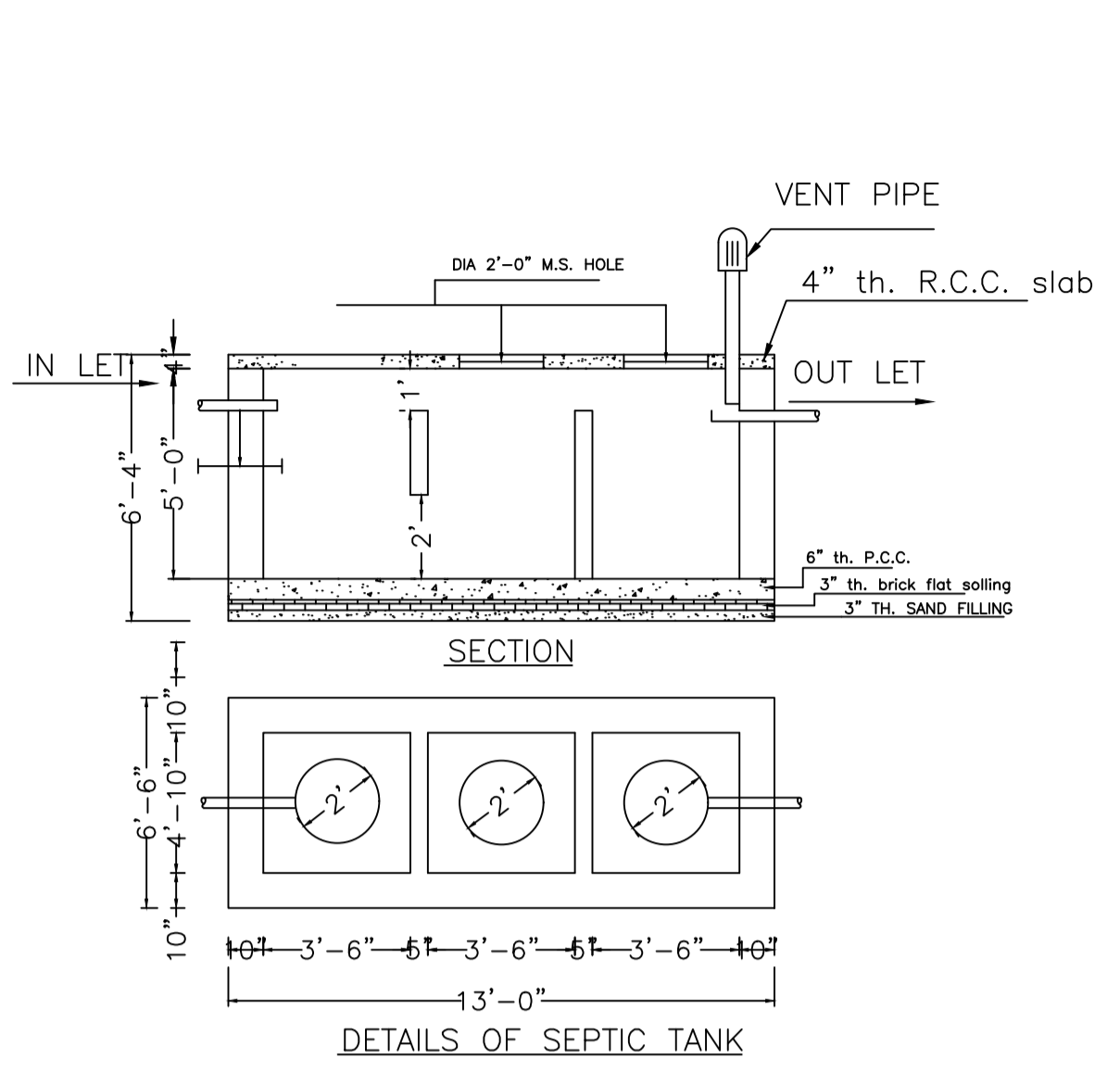
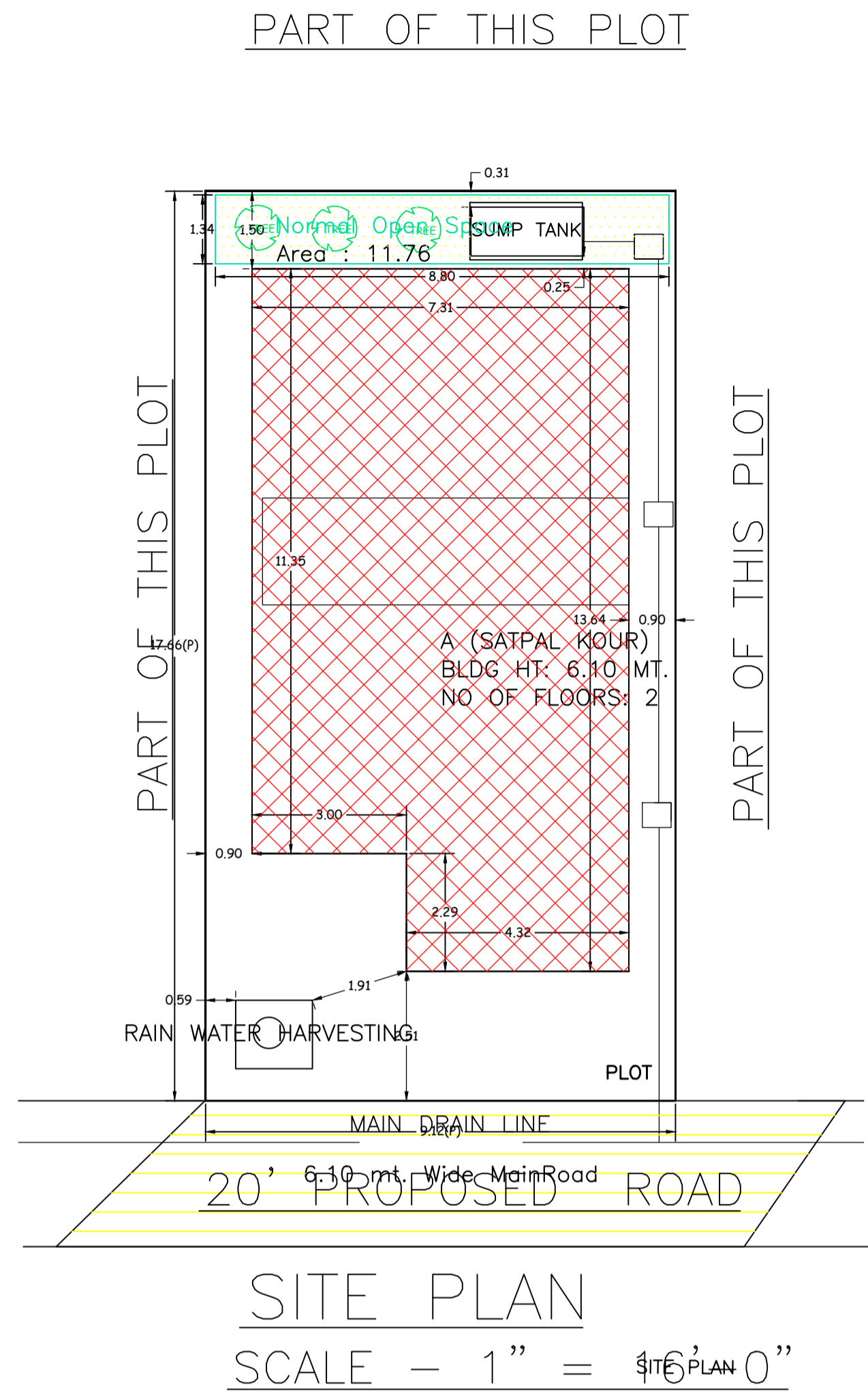

UnitBUA Table for Building :A (SATPAL KOUR)						
FLOOR	Name	UnitBUA Type	UnitBUA Area	Carpet Area	No. of Rooms	No. of Tenement
GROUND FLOOR PLAN	SPLIT 1	FLAT	176.01	173.25	6	1
FIRST FLOOR PLAN	SPLIT 1	FLAT	0.00	0.00	7	0
Total:	-	-	176.01	173.25	13	1

SCHEDULE OF DOOR:				
BUILDING NAME	NAME	LENGTH	HEIGHT	NOS
A (SATPAL KOUR)	D	0.76	2.10	03
A (SATPAL KOUR)	D	0.98	2.10	02
A (SATPAL KOUR)	D	0.99	2.10	01
A (SATPAL KOUR)	D	1.02	2.10	02
A (SATPAL KOUR)	D	1.07	2.10	02

SCHEDULE OF WINDOW/VENTILATION:				
BUILDING NAME	NAME	LENGTH	HEIGHT	NOS
A (SATPAL KOUR)	W	0.61	1.20	07
A (SATPAL KOUR)	W	1.12	1.20	01
A (SATPAL KOUR)	W	1.22	1.20	09
A (SATPAL KOUR)	W	1.24	1.20	01
A (SATPAL KOUR)	W	1.47	1.20	01

Building :A (SATPAL KOUR)					
Floor Name	Total Built Up Area (Sq.mt.)	Proposed FAR Area (Sq.mt.)	Total FAR Area (Sq.mt.)	Total Consumed Additional FAR Area (Sq.mt.)	Tnmt (No.)
Ground Floor	92.92	92.92	92.92	92.92	01
First Floor	83.09	83.09	83.09	83.09	00
Terrace Floor	0.00	0.00	0.00	0.00	00
Total :	176.01	176.01	176.01	176.01	01
Total Number of Same Buildings	1				
Total :	176.01	176.01	176.01	176.01	01

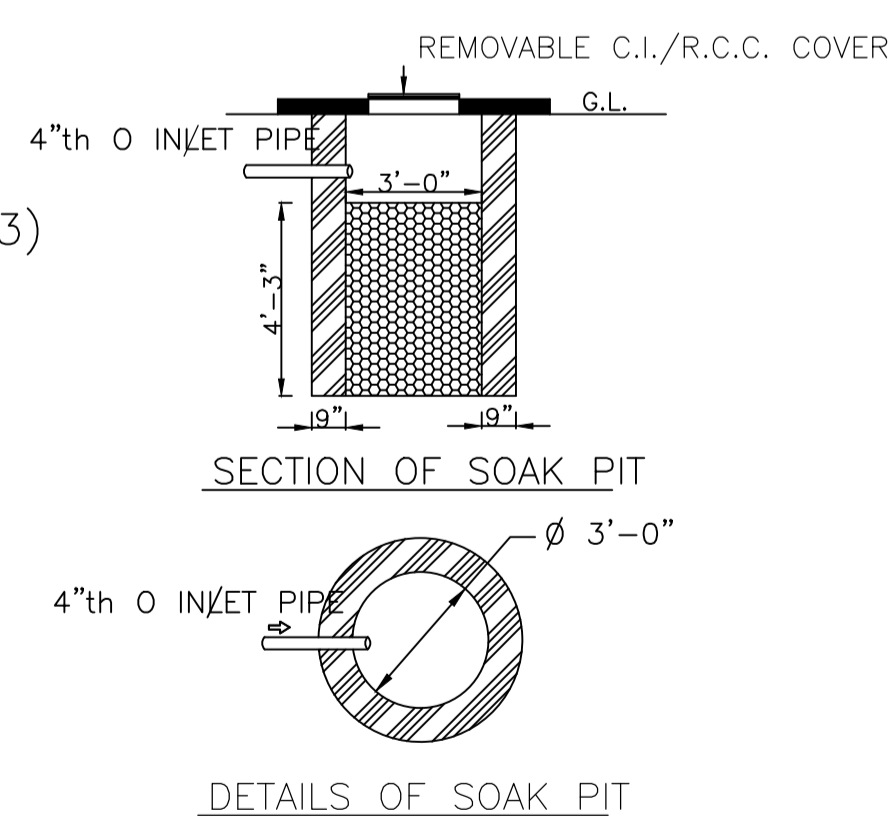
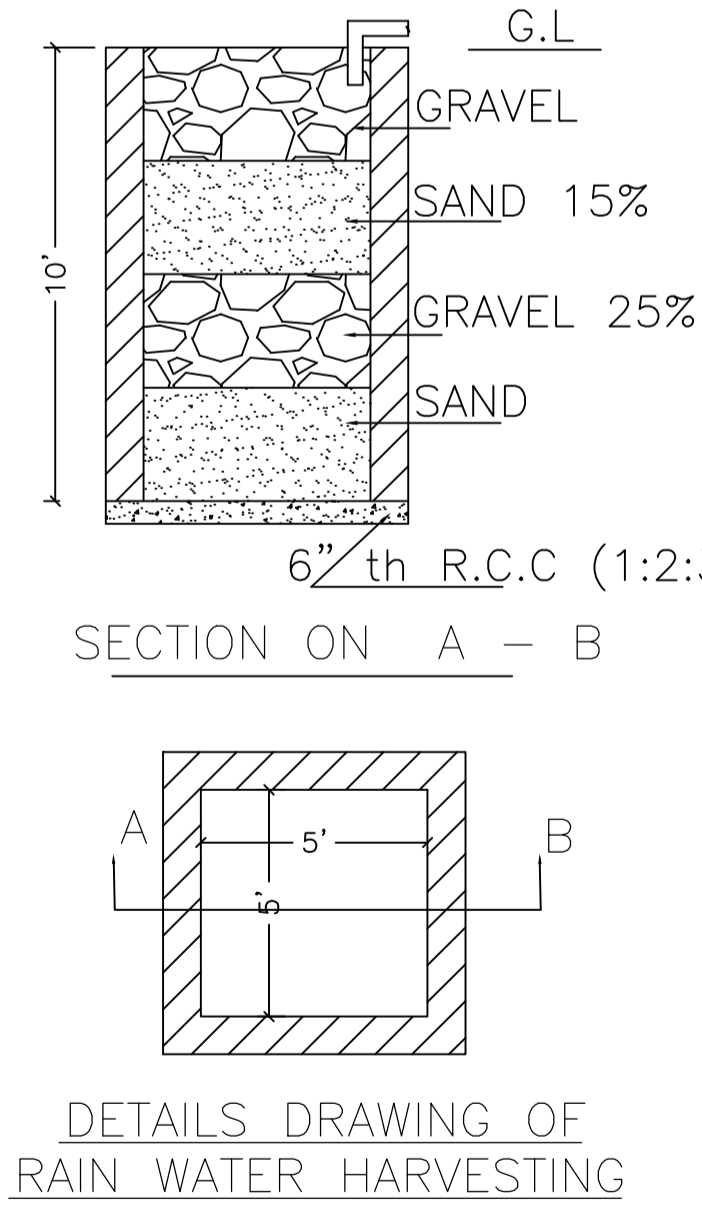
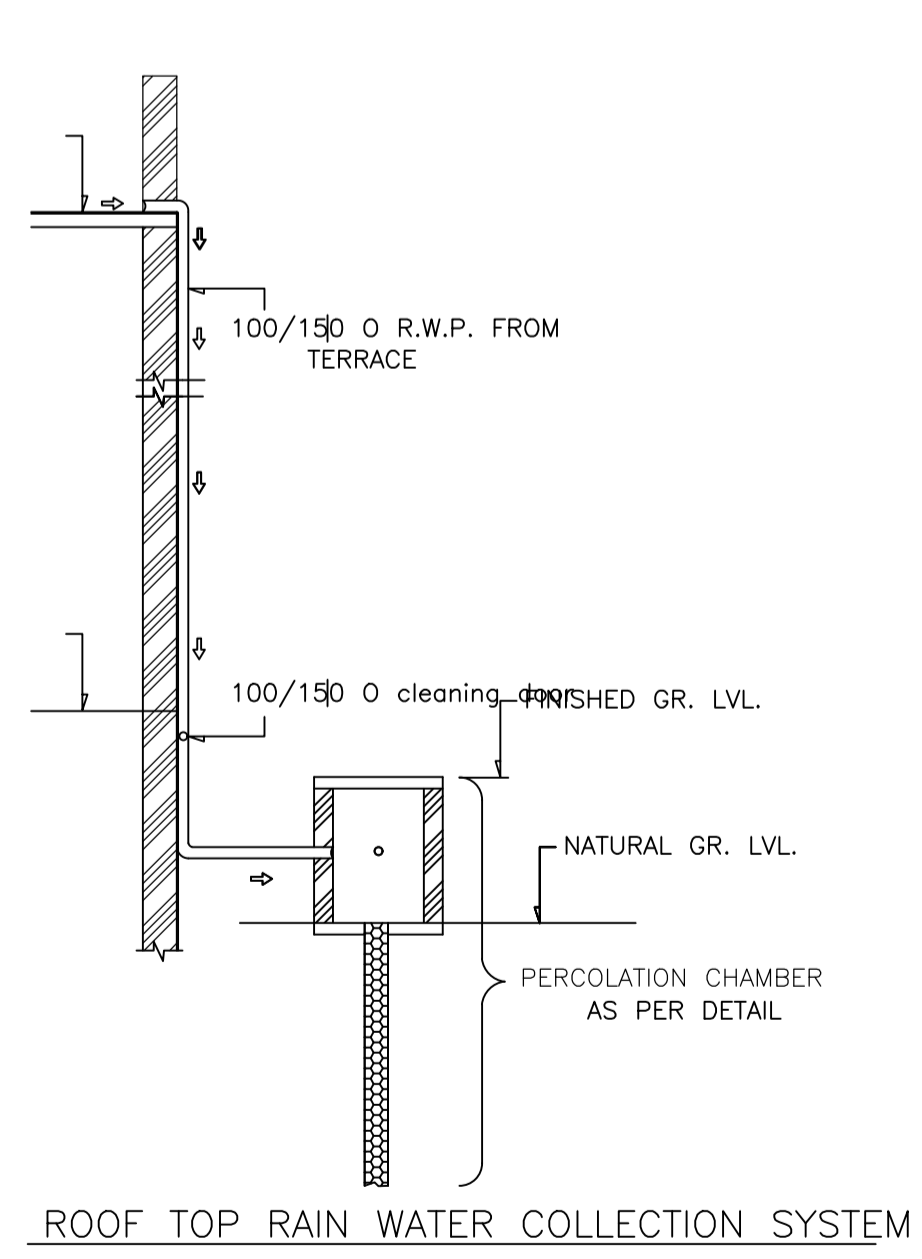
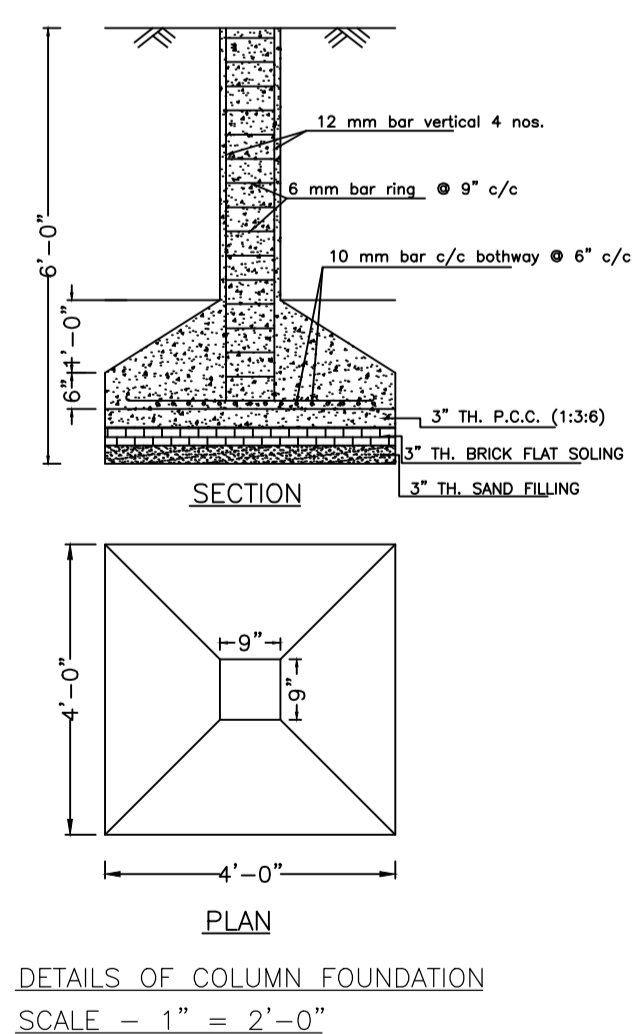

Proposal Basic Information	
Proposal File No.	MADA/BP/0174/2023
Owner Name	SMT. SATPAL KOUR
Khata No	OLD KHATA NO-74, NEW KHATA NO-189
Plot No	OLD PLOT NO-337, NEW PLOT NO-1160
Village Name	Amaghata
Use	Residential
SubUse	Bungalow/ Dwelling / Non Apartment

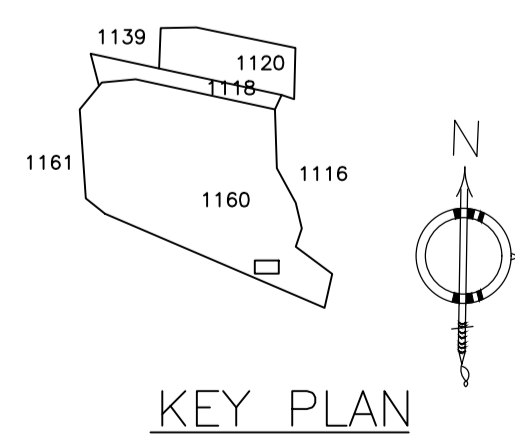
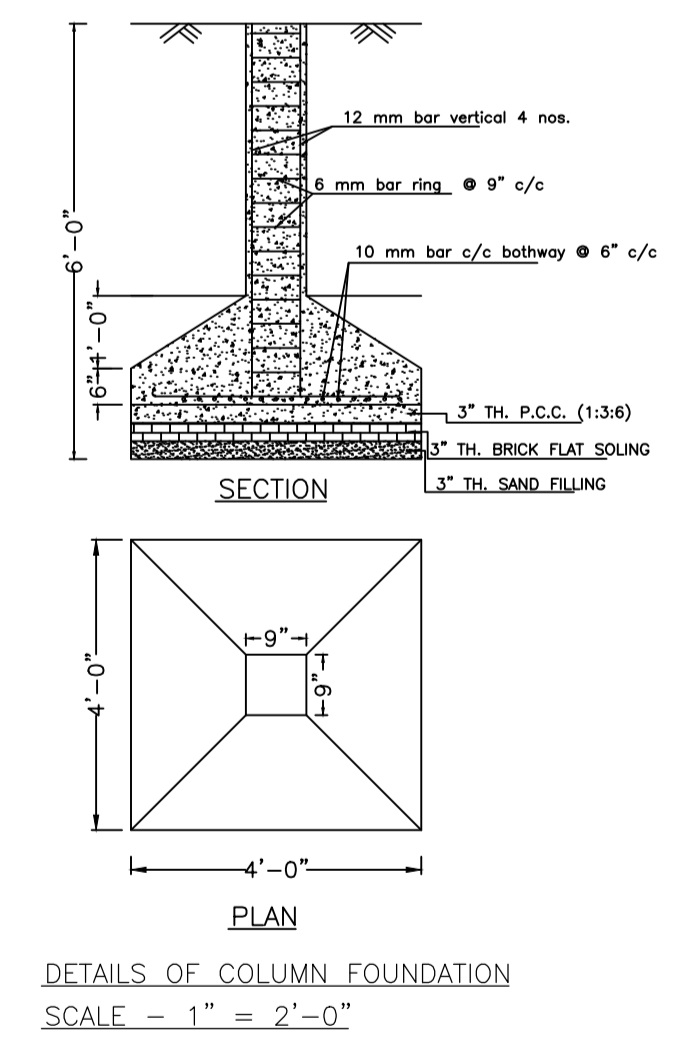
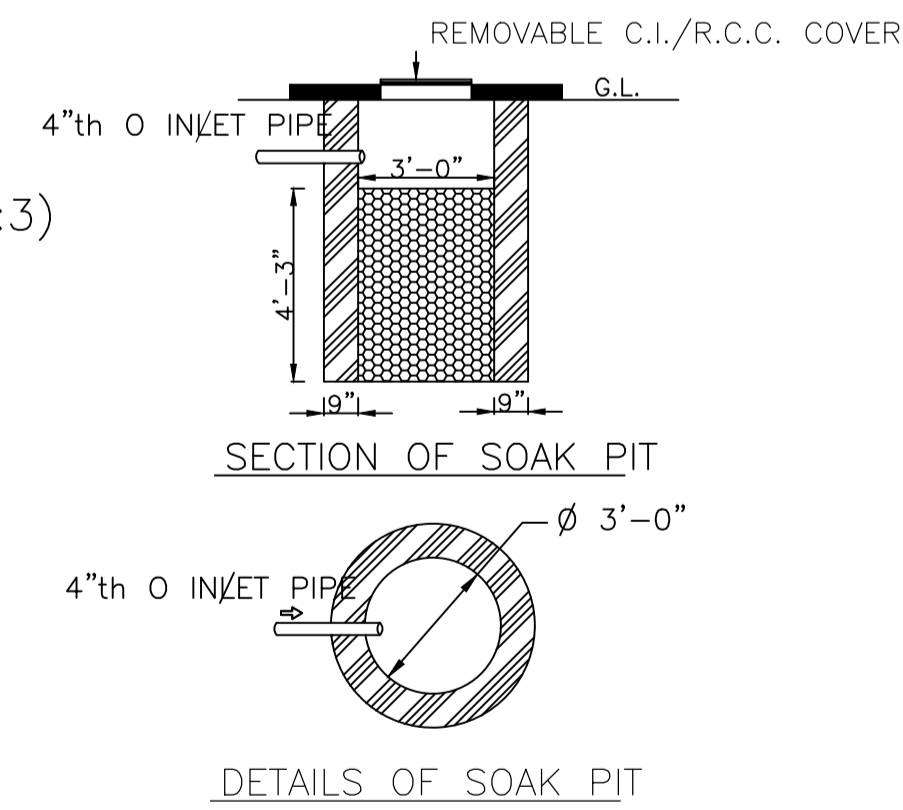
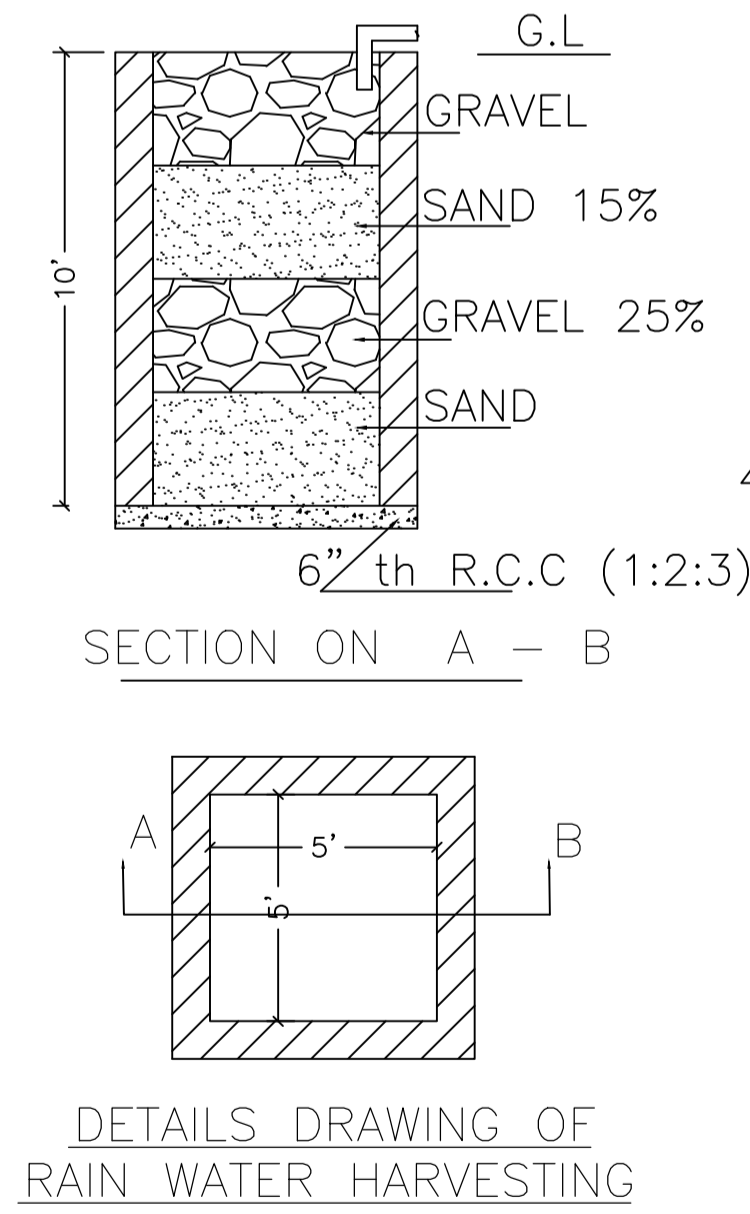
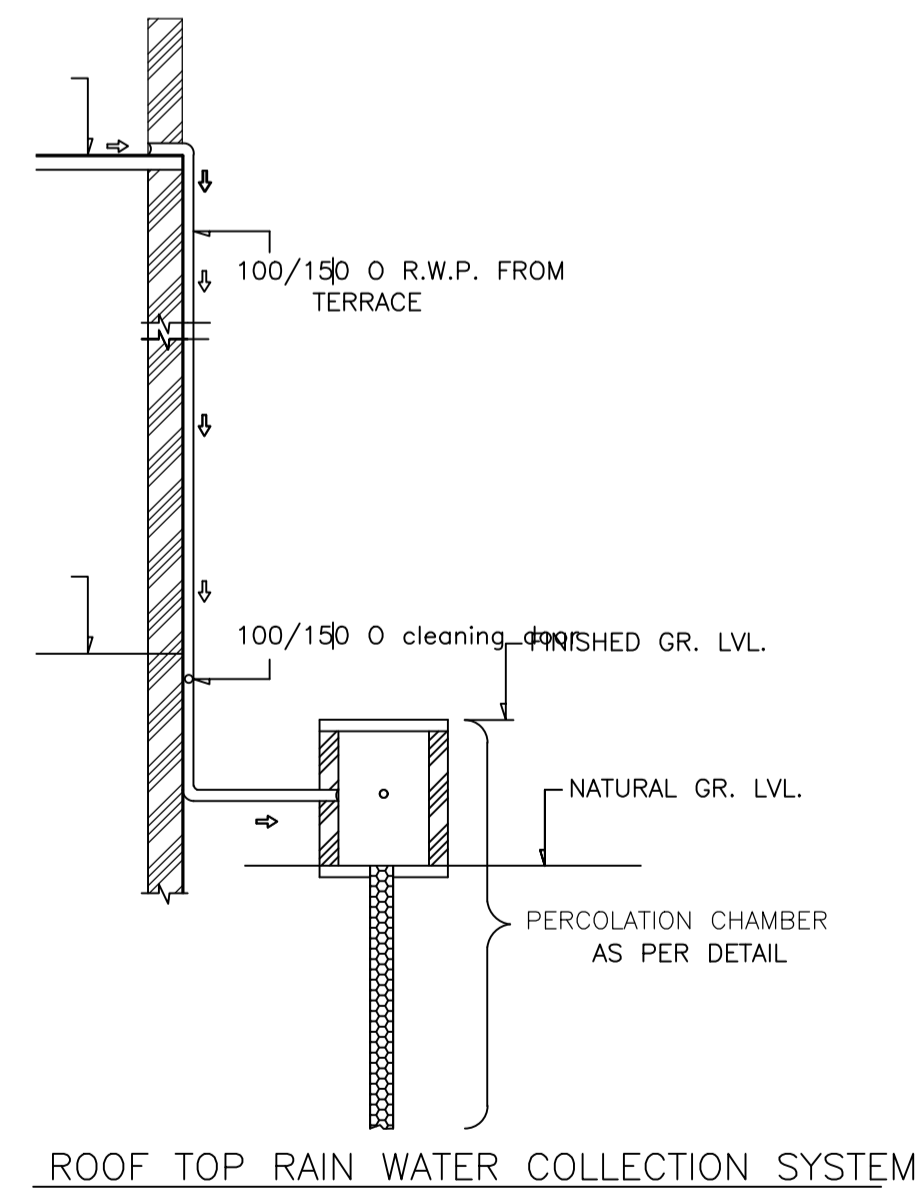
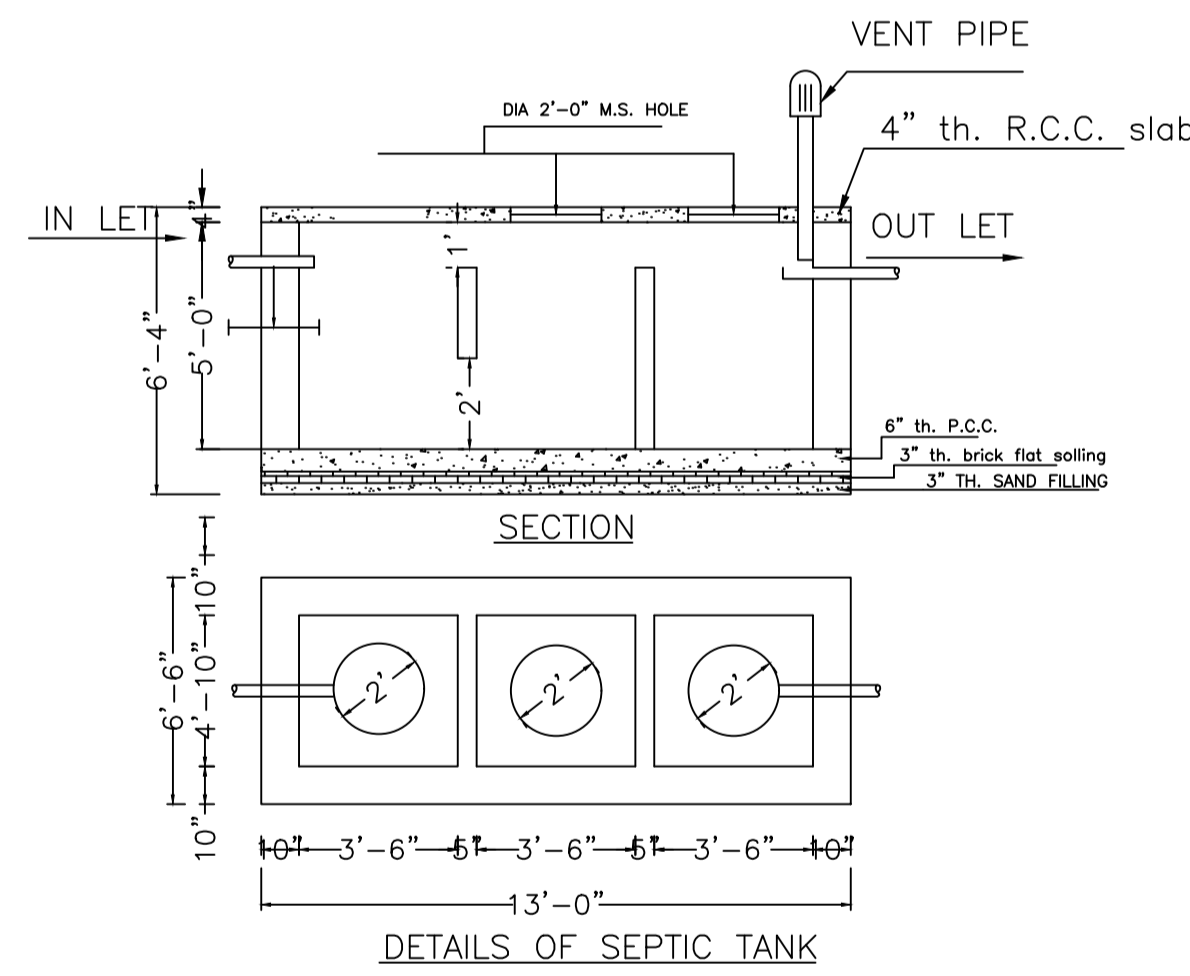
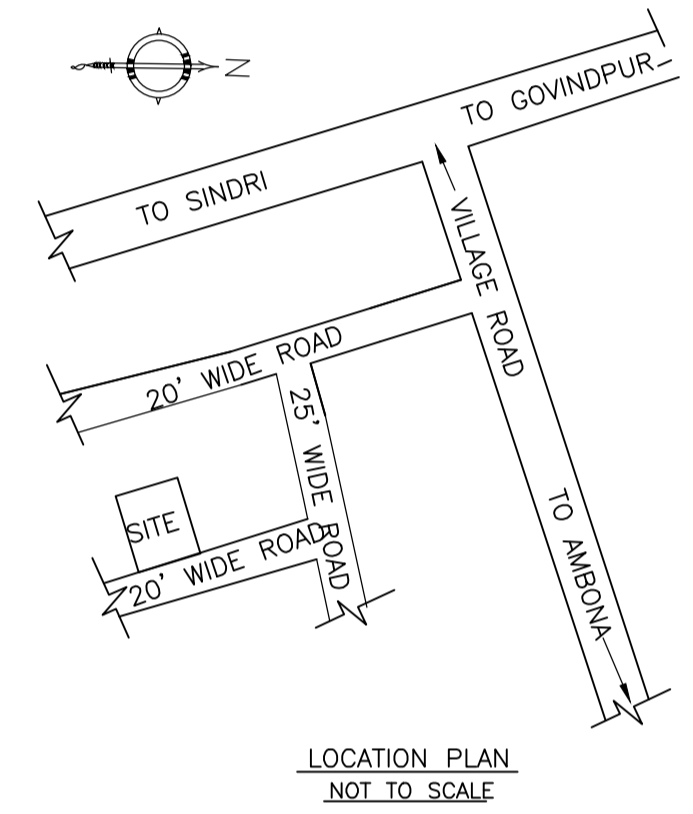
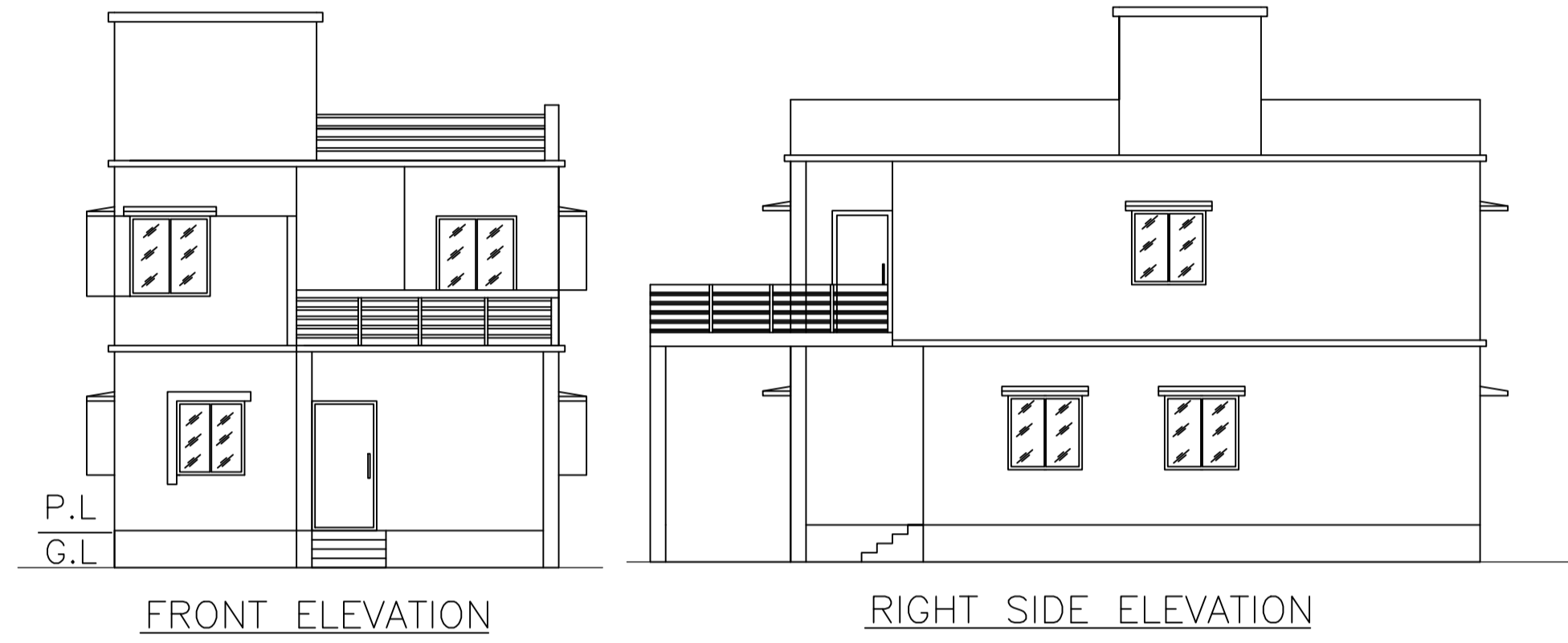
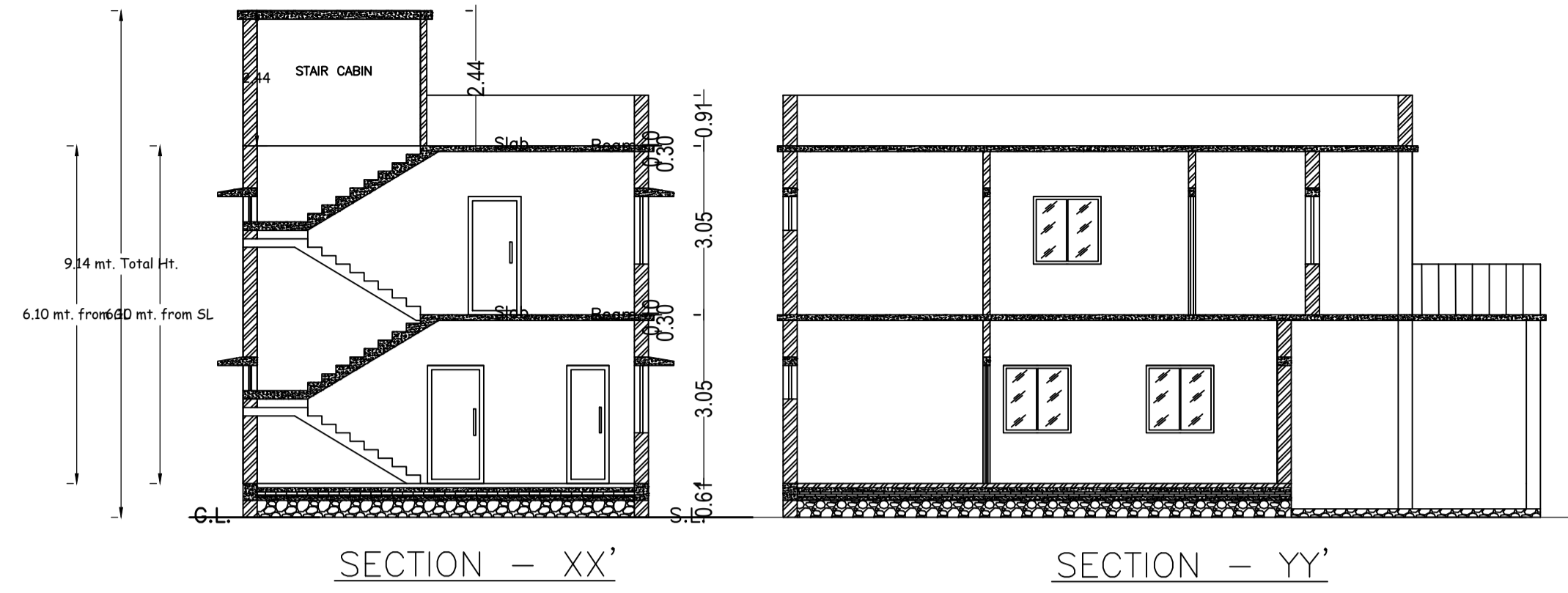
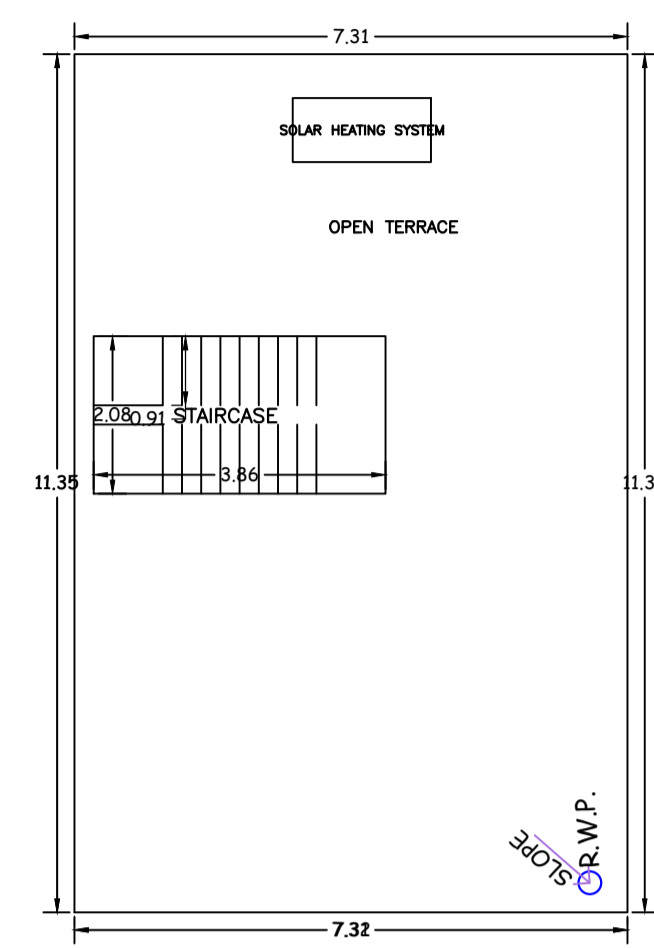
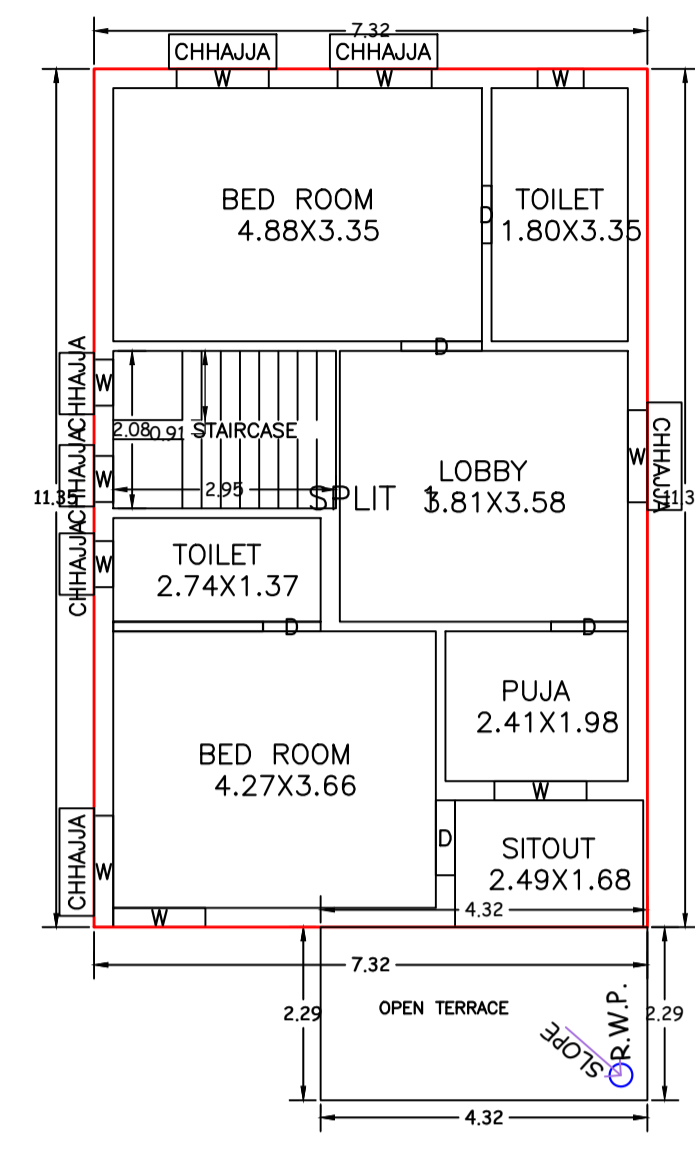
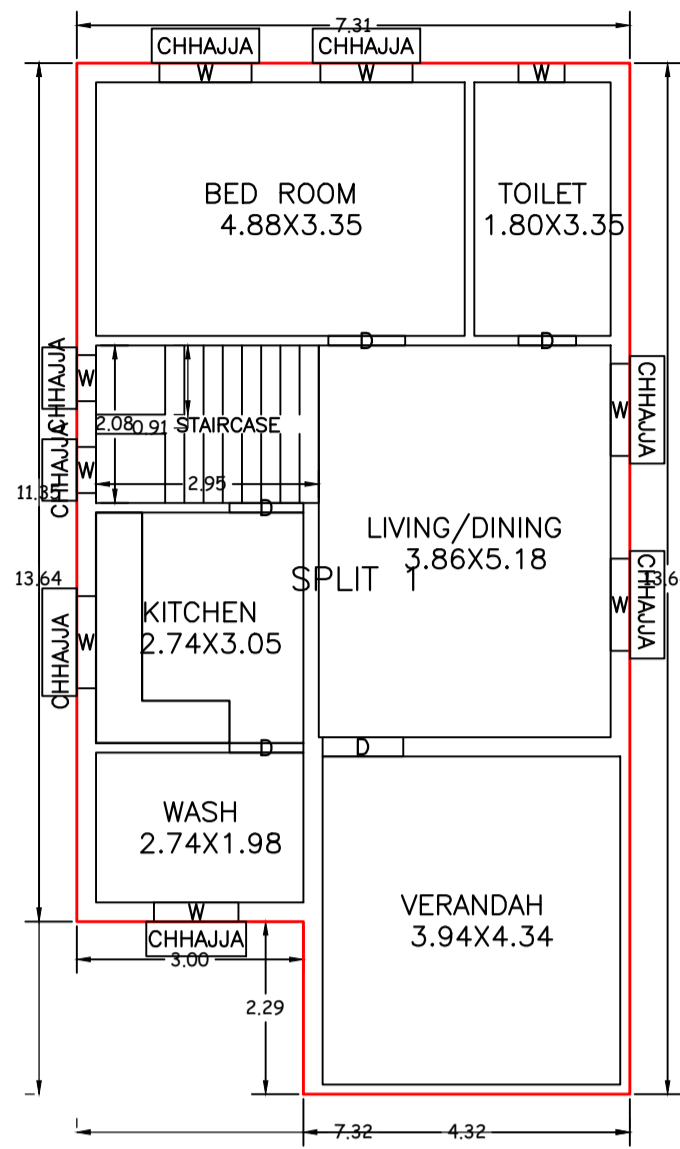

LTP NAME AND SIGNATURE	STRUCTURAL ENG'S NAME AND SIGNATURE	BUILDER NAME AND SIGNATURE	DIGITAL SIGNATURE
RAM PRATAP SINGH MADA/ARC/0024/2019			