

Proposal Basic Information	
Proposal File No.	MADA/BP/0049/2023
Owner Name	SMT SUNITA SINGH
Khata No	78 (OLD), 170 (NEW)
Plot No	1137 (OLD), 1129 (NEW)
Village Name	Navadhi
Use	Residential
SubUse	Bungalow/ Dwelling / Non Apartment

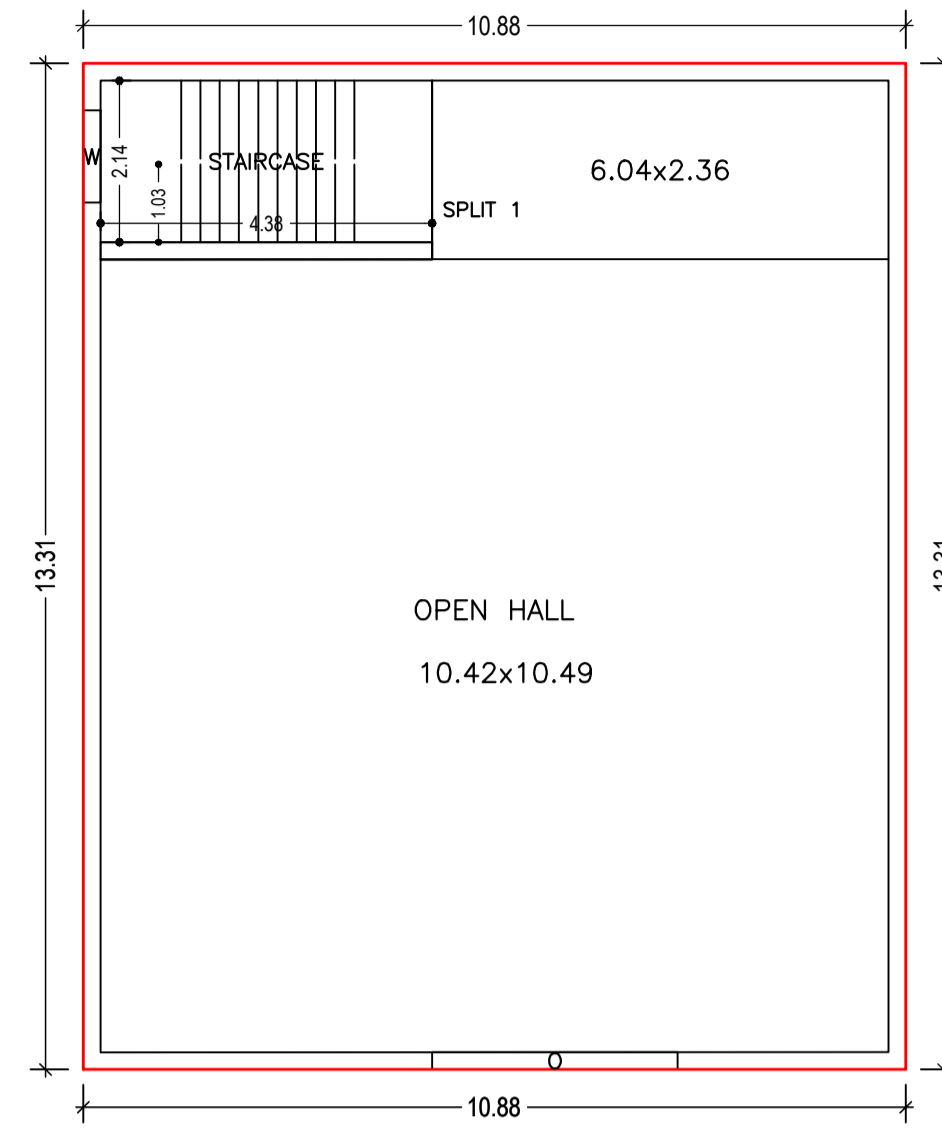

GROUND FLOOR PLAN (Proposed) (SCALE 1:100)

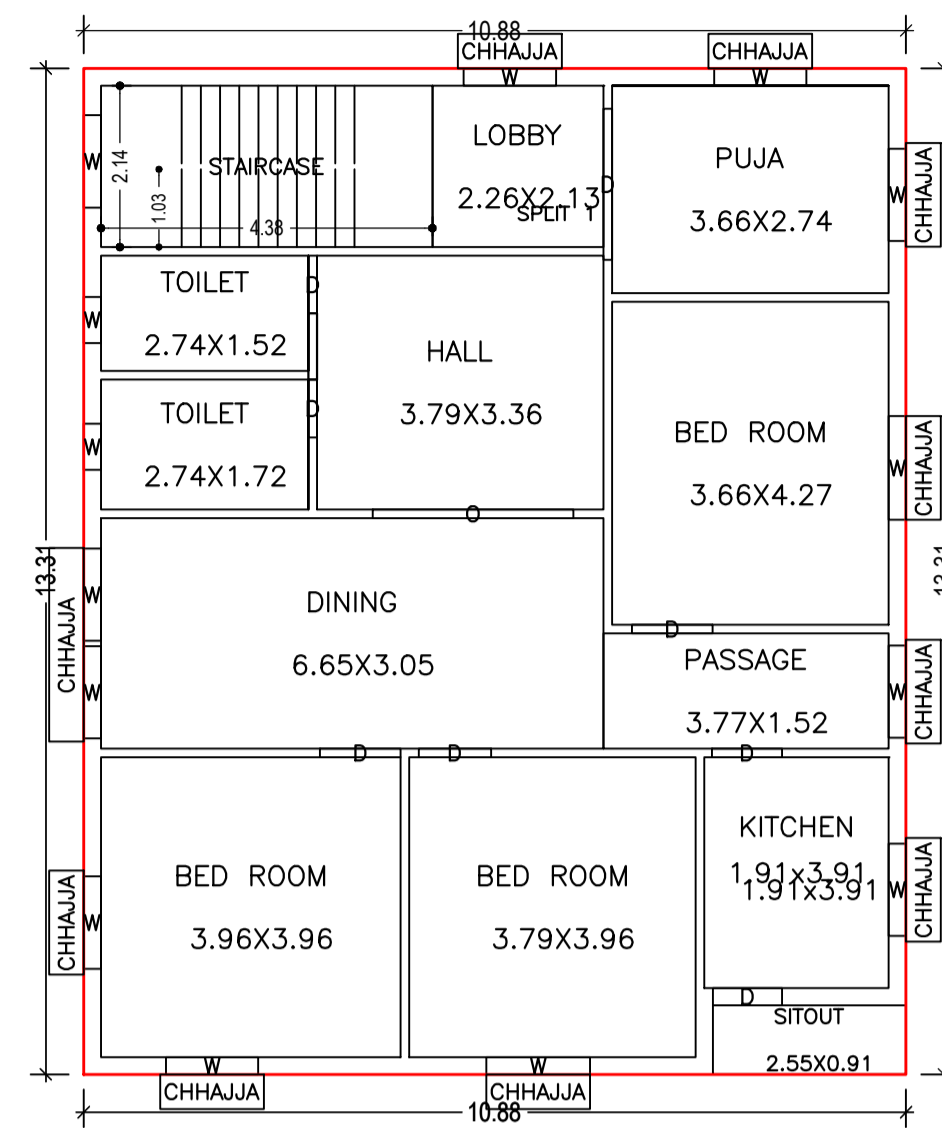

TYPICAL - FIRST & SECOND FLOOR PLAN (Proposed) (SCALE 1:100)

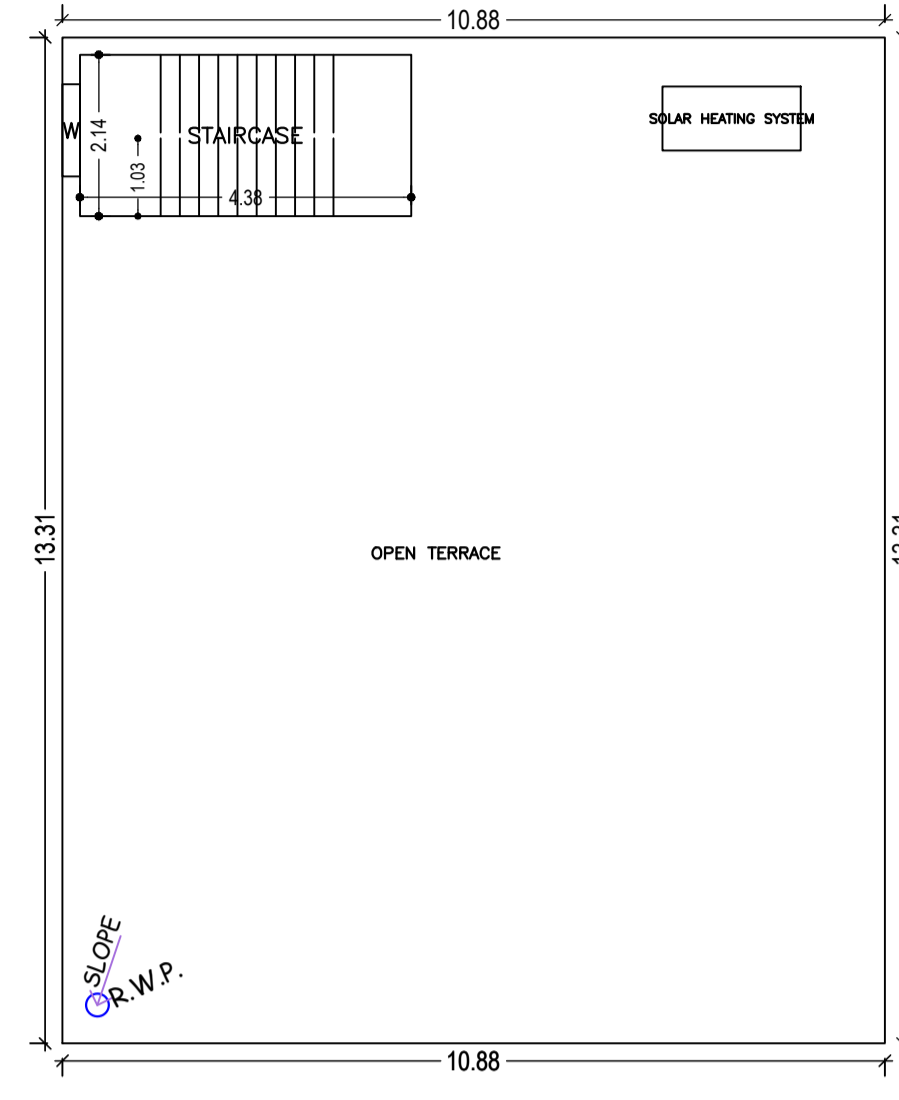

TERRACE FLOOR PLAN (SCALE 1:100)

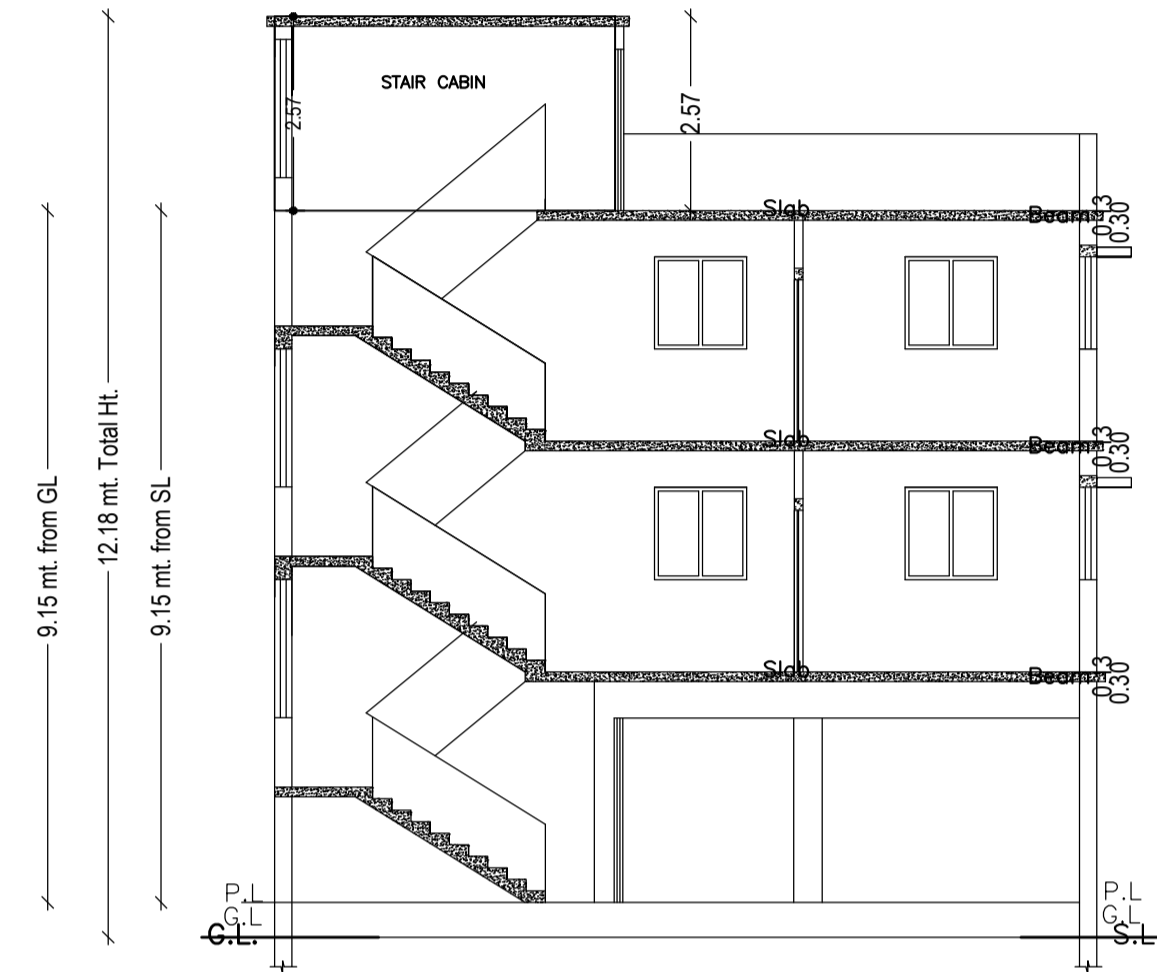
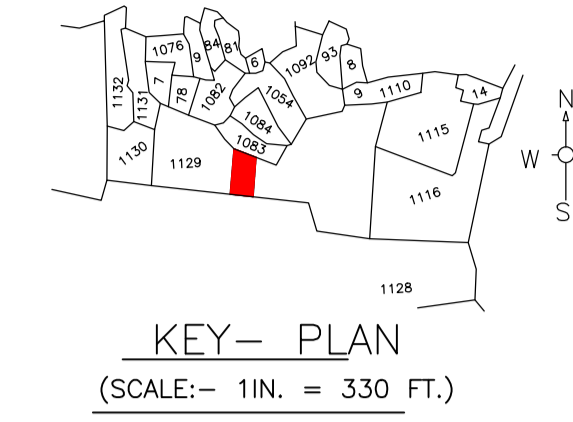

SECTION AT X-X

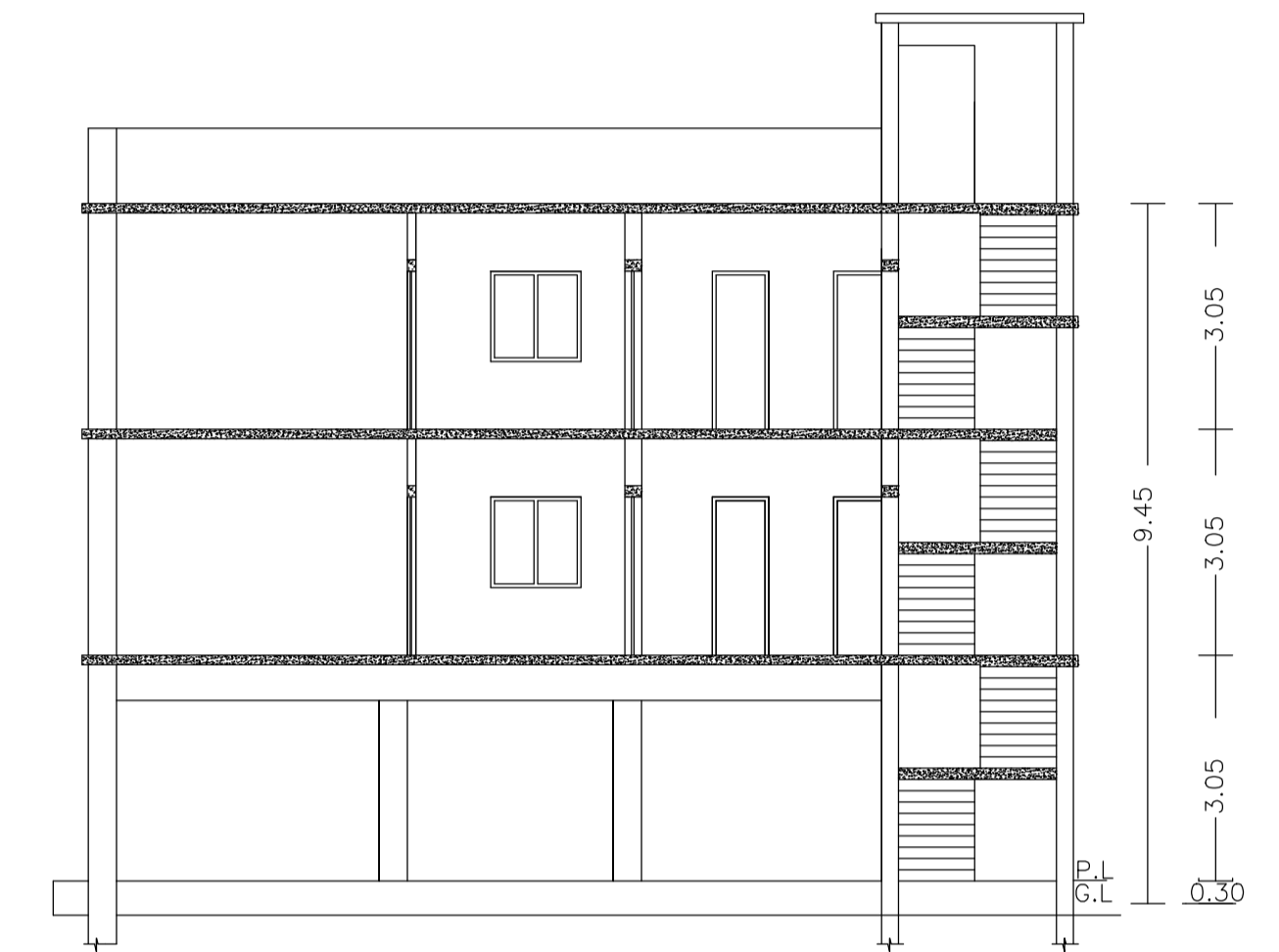

SECTION AT Y-Y

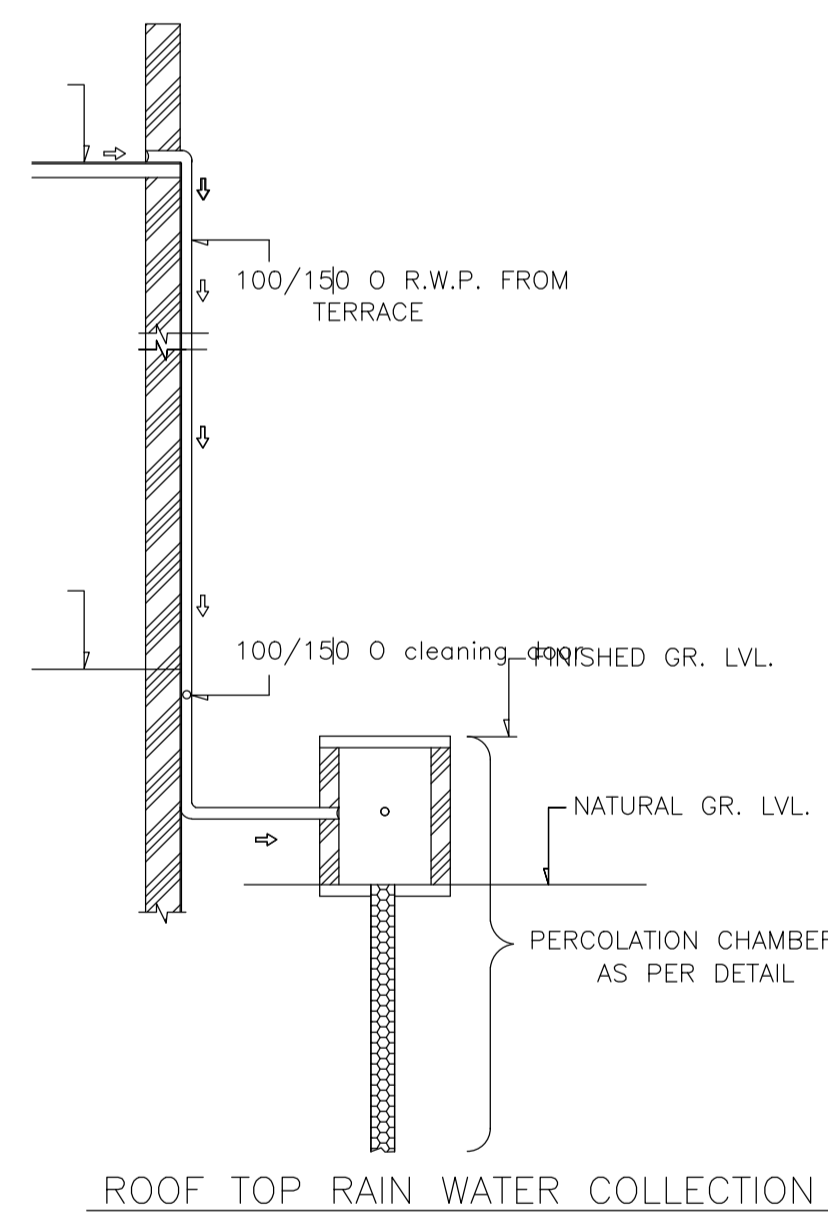

ROOF TOP RAIN WATER COLLECTION SYSTEM

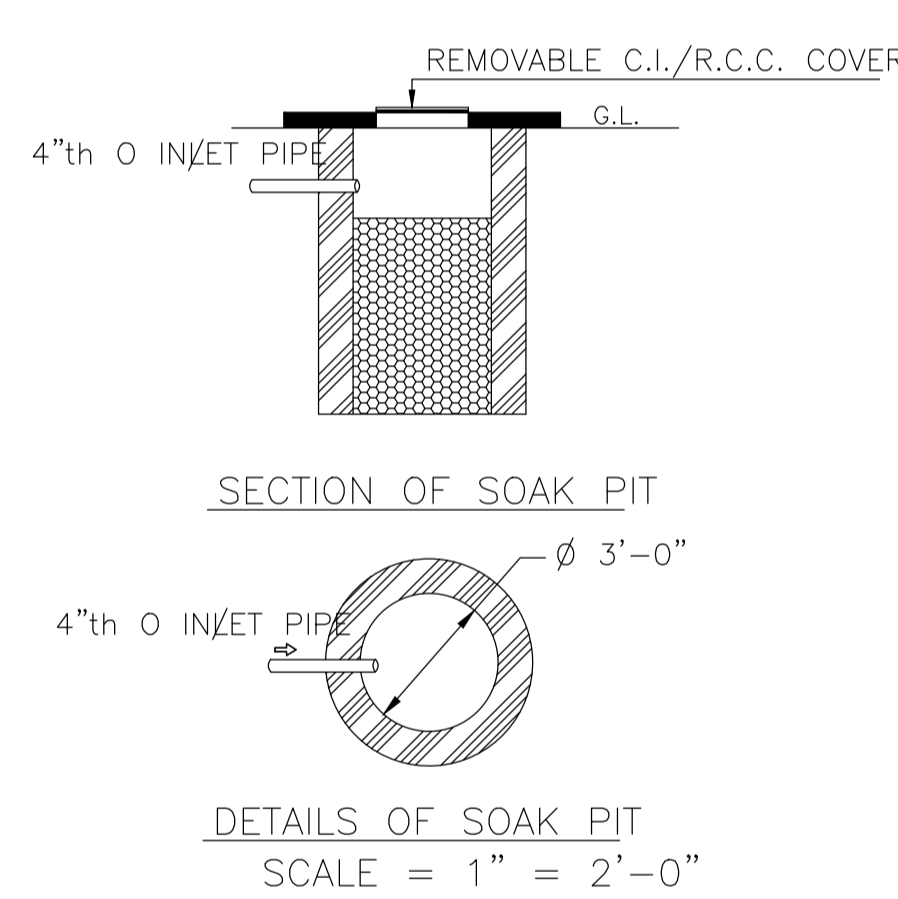

DETAILS OF SOAK PIT SCALE = 1" = 2'-0"

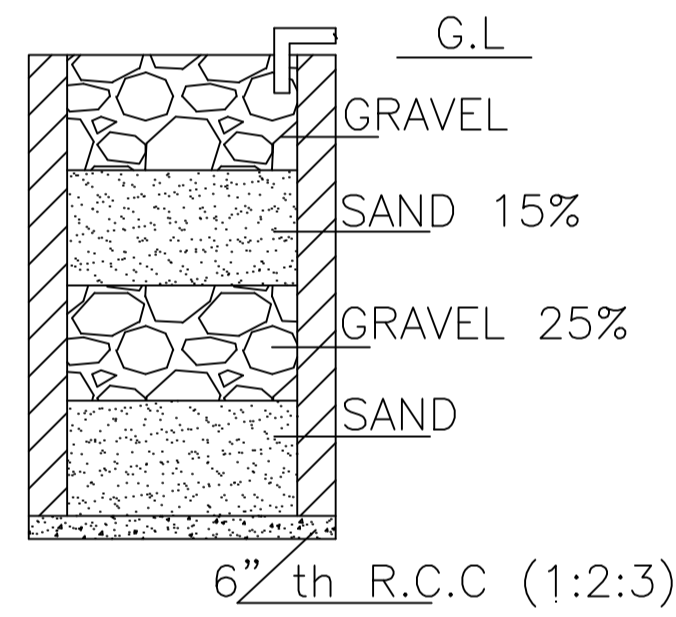

SECTION ON A - B

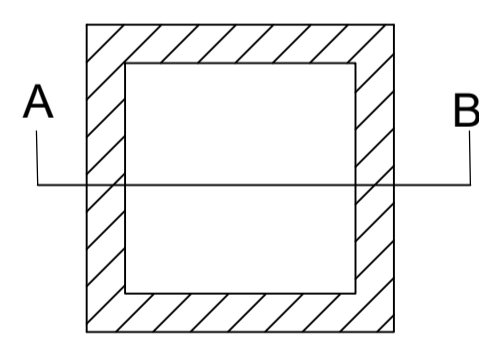

DETAILS DRAWING OF RAIN WATER HARVESTING

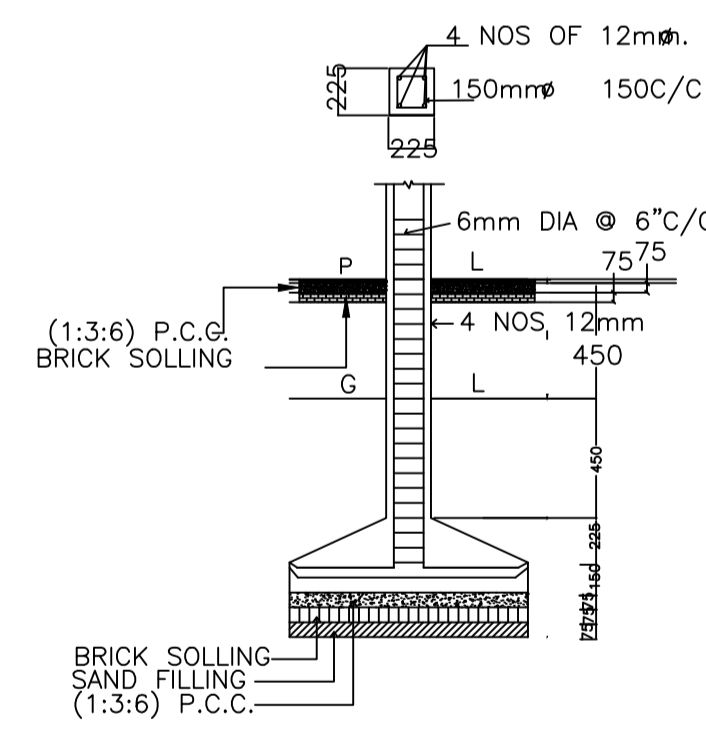

DETAILS OF COLUMN FOOTING

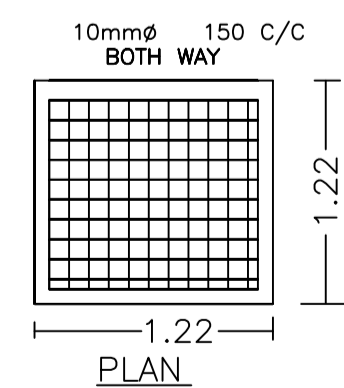

DETAILS OF COLUMNS (SCALE: 1:50)

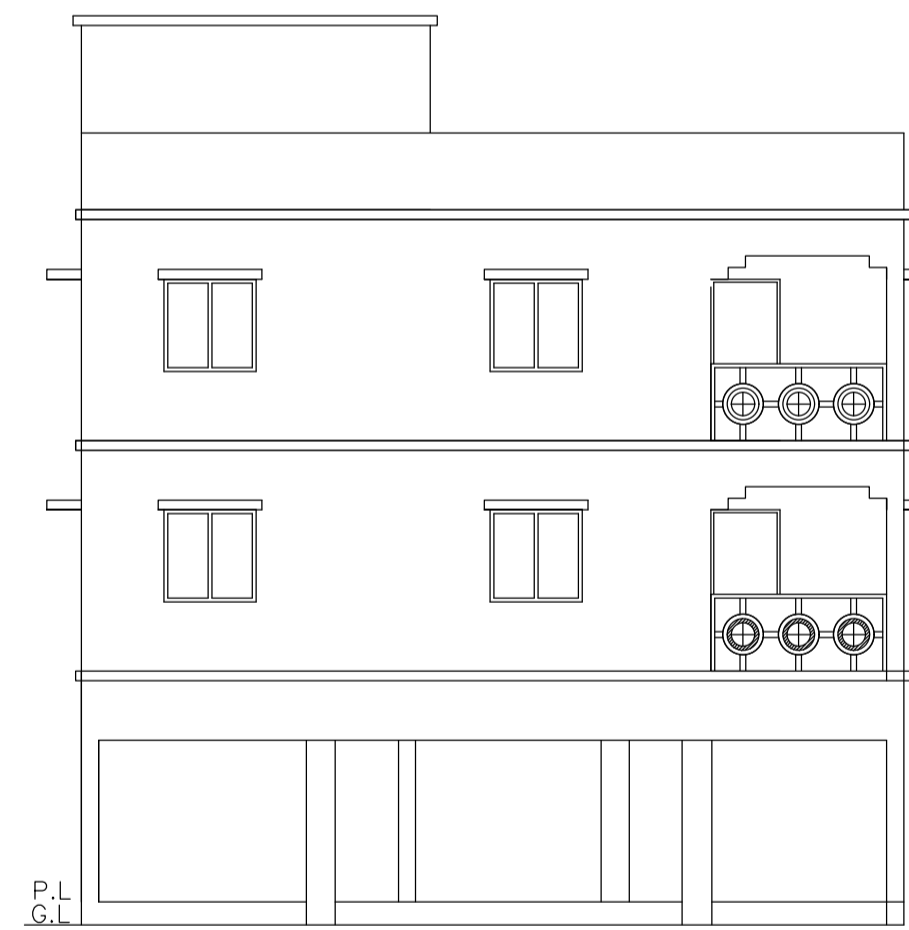

LEFT SIDE ELEVATION

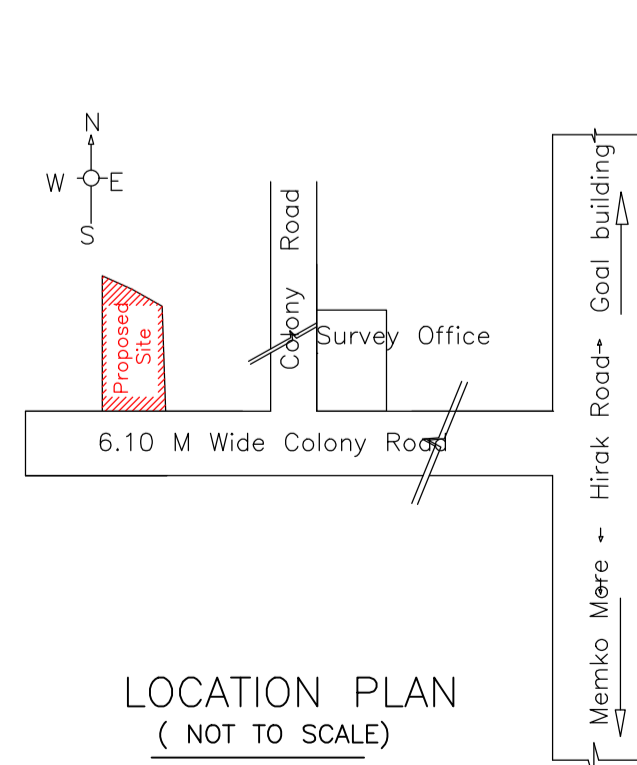
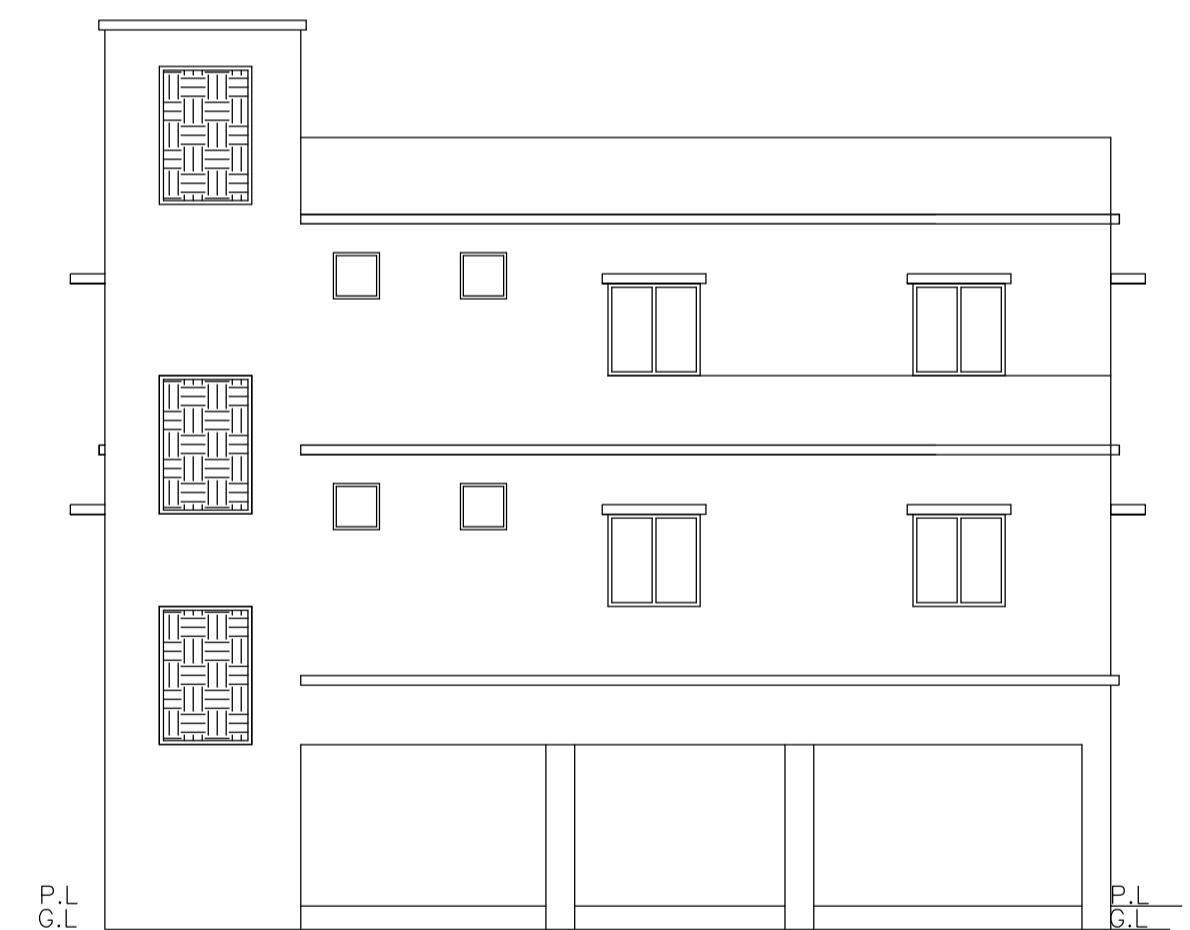

LOCATION PLAN (NOT TO SCALE)

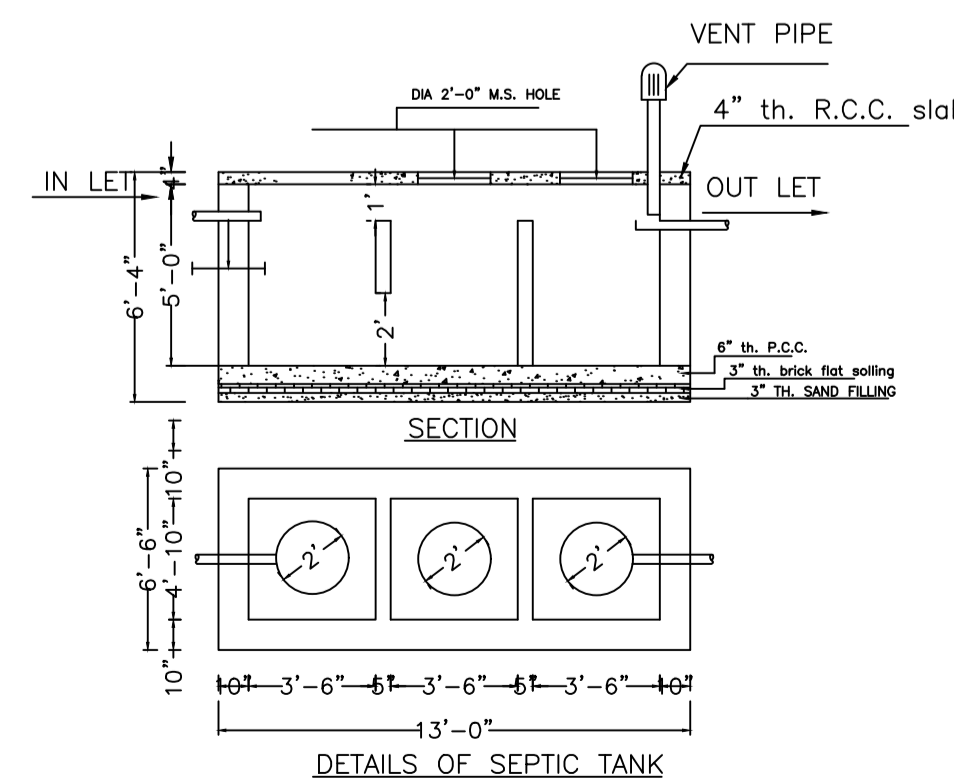

DETAILS OF SEPTIC TANK

LTP NAME AND SIGNATURE	STRUCTURAL ENG'S NAME AND SIGNATURE	BUILDER NAME AND SIGNATURE	DIGITAL SIGNATURE
Lalan Prasad Singh MADA/ENG/0001/2020			