

Proposal Basic Information

Proposal File No.	MADA/BP/0231/2023
Owner Name	DURGA KUMARI
Khata No	OLD-53,66 NEW-126,53
Plot No	OLD-737, 739 NEW-860, 862
Village Name	Sabalpur
Use	Residential
SubUse	Bungalow/ Dwelling / Non Apartment

AREA STATEMENT MINERAL	VERSION NO. : 1.0.66
AREA DEVELOPMENT AUTHORITY	VERSION DATE: 16/10/2020
PROJECT DETAIL:	
Region: JHARKHAND URBAN LOCAL BODIES	Plot Use: Residential
District: DHANBAD	Plot SubUse: Bungalow/ Dwelling / Non Apartment
Authority: MINERAL AREA DEVELOPMENT AUTHORITY	PlotNearbyReligiousStructure: NA
Inward No: MADA/BP/0231/2023	PlotSubPlot No: OLD-737, 739 NEW-860, 862
Application Type: General Proposal	North: Plot No. - PART OF THIS PLOT
Project Type: Building Permission	South: Plot No. - NEW PLOT NO 860
Nature of Development: New	East: Plot No. - DHARUN MAHTO
Location of Development Area: Old Area	West: Road Width - 5.18

AREA OF PLOT (Minimum)	(A)	SQ.MT.	194.97
NET AREA OF PLOT(Gross Plot Area - Deduction from Gross Plot area)	(A-Deductions)		194.97
Deduction for Balance Plot Area(from Gross Plot Area)			
Common Plot			25.21
Total			25.21
BALANCE AREA OF PLOT(Net Plot Area - Recreational/Amenity space)	(A-Deductions)		169.76
PLOT AREA FOR COVERAGE(Net Plot Area)	(A-Deductions)		194.97
Plot Area for FAR (Net Plot Area + RoadWidening Area)	(A-Deductions)		194.97

COVERAGE CHECK			
Permissible Coverage area (70.00 %)			136.48
Proposed Coverage Area (56.31 %)			109.79
Total Prop. Coverage Area (56.31 %)			109.79
Balance coverage area (13.69 %)			26.69
FAR CHECK			
Perm. FAR Area (1.800)			350.95
Total Perm. FAR area			350.95
Residential FAR			219.58
Proposed FAR Area			219.58
Total Proposed FAR Area			219.58
Consumed FAR (Factor)			1.13
Balance FAR Area			131.37
BUILT UP AREA CHECK			
Total Proposed BuiltUp Area			219.58
ARCHITECT (Regd)			
Lalan Prasad Singh			
ENGINEER (Regd)			
SUPERVISOR (Regd)			
OWNER (Regd)			
DURGA KUMARI			
DEVELOPMENT AUTHORITY			
LOCAL BODY			

COLOR INDEX	
PLOT BOUNDARY	Black
ABUTTING ROAD	Red
PROPOSED CONSTRUCTION	Green
COMMON PLOT	Yellow
ROAD WIDENING AREA	Blue
EXISTING (To be retained)	Orange
EXISTING (To be demolished)	Grey

Buildingwise Floor FAR Details

Floor Name	Building Name		Total	
	Proposed Built Up Area (Sq.mt.)	Proposed FAR Area (Sq.mt.)	Total Proposed Built Up Area (Sq.mt.)	Total FAR Area (Sq.mt.)
Ground Floor	109.79	109.79	109.79	109.79
First Floor	109.79	109.79	109.79	109.79
Terrace Floor	0.00	0.00	0.00	0.00
Total :	219.58	219.58	219.58	219.58

Building USE/SUBUSE Details

Building Name	Building Use	Building SubUse	Building Structure
A (A)	Residential	Bungalow/ Dwelling / Non Apartment	Non-Highrise

FAR & Tenement Details (Table 4c-1)

Building	No. of Same Bldg	Total Built Up Area (Sq.mt.)	Proposed FAR Area (Sq.mt.)	Total FAR Area (Sq.mt.)	Total Consumed Additional FAR Area (Sq.mt.)	Tnmt (No.)
A (A)	1	219.58	219.58	219.58	219.58	01
Grand Total :	1	219.58	219.58	219.58	219.58	01

UnitBUA Table for Building :A (A)

FLOOR	Name	UnitBUA Type	UnitBUA Area	Carpet Area	No. of Rooms	No. of Tenement
GROUND FLOOR PLAN	SPLIT A	FLAT	219.58	219.51	8	1
FIRST FLOOR PLAN	SPLIT A	FLAT	0.00	0.00	8	0
Total:	-	-	219.58	219.51	16	1

Building :A (A)

Floor Name	Total Built Up Area (Sq.mt.)	Proposed FAR Area (Sq.mt.)	Total FAR Area (Sq.mt.)	Total Consumed Additional FAR Area (Sq.mt.)	Tnmt (No.)
Ground Floor	109.79	109.79	109.79	109.79	01
First Floor	109.79	109.79	109.79	109.79	00
Terrace Floor	0.00	0.00	0.00	0.00	00
Total :	219.58	219.58	219.58	219.58	01
Total Number of Same Buildings :	1				
Total :	219.58	219.58	219.58	219.58	01

SCHEDULE OF DOOR:

BUILDING NAME	NAME	LENGTH	HEIGHT	NOS
A (A)	D	0.76	2.10	04
A (A)	D	1.07	2.10	14

SCHEDULE OF WINDOW/VENTILATION:

BUILDING NAME	NAME	LENGTH	HEIGHT	NOS
A (A)	V	0.61	1.20	04
A (A)	W	1.22	1.20	23

LTP NAME AND SIGNATURE	STRUCTURAL ENG'S NAME AND SIGNATURE	BUILDER NAME AND SIGNATURE	DIGITAL SIGNATURE
Lalan Prasad Singh MADA/ENG/0001/2020			

Proposal Basic Information	
Proposal File No.	MADA/BP/0231/2023
Owner Name	DURGA KUMARI
Khata No	OLD-53,66 NEW-126,53
Plot No	OLD-737, 739 NEW-860, 862
Village Name	Sabalpur
Use	Residential
SubUse	Bungalow/ Dwelling / Non Apartment

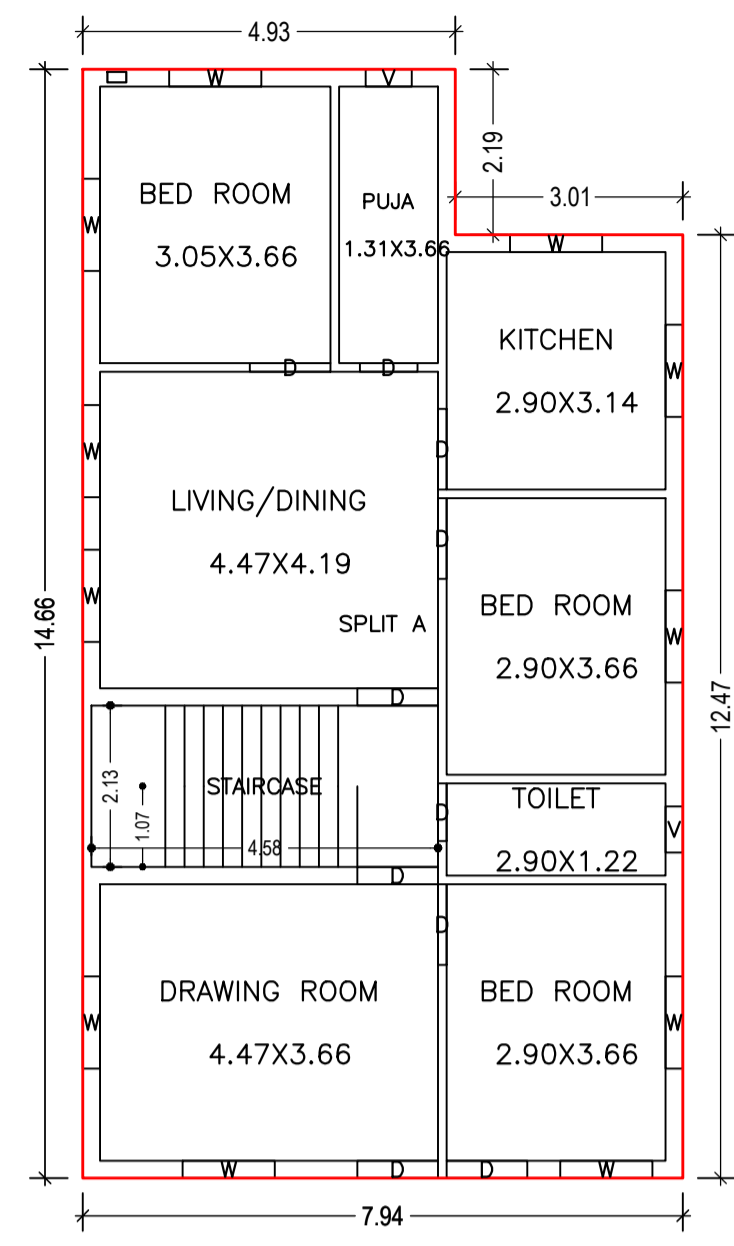

GROUND FLOOR PLAN (Proposed) (SCALE 1:100)

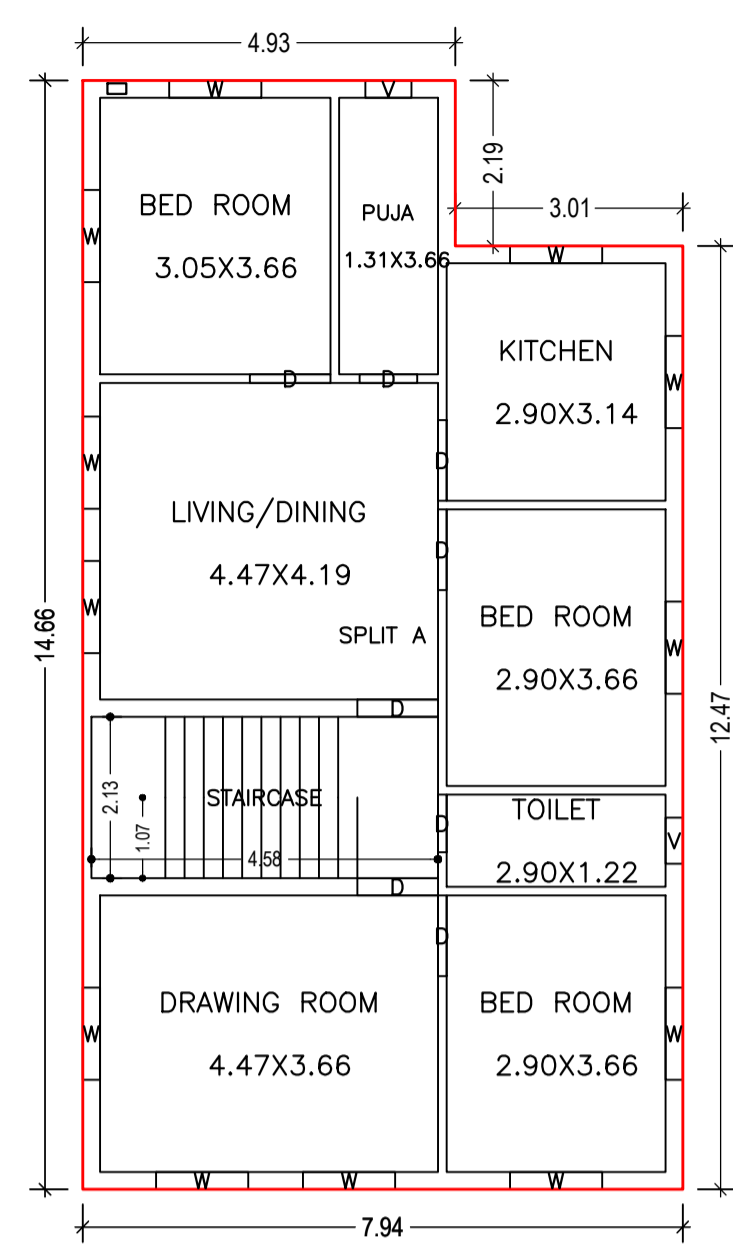

FIRST FLOOR PLAN (Proposed) (SCALE 1:100)

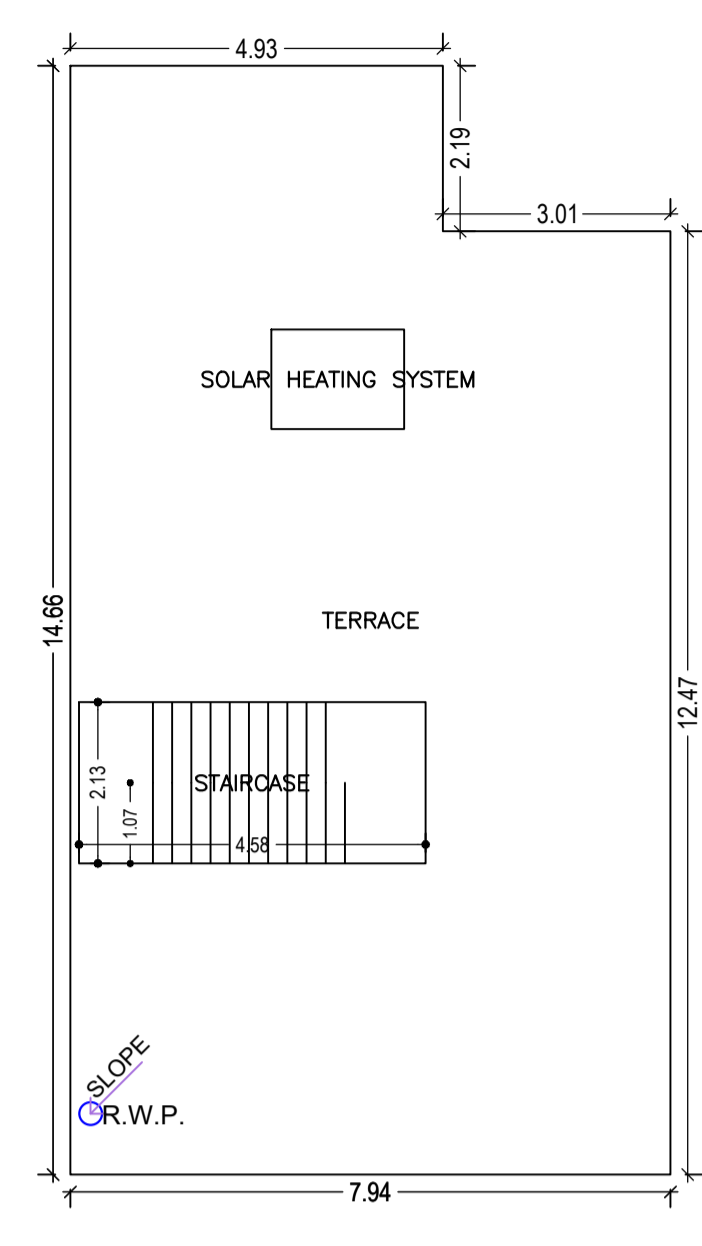

TERRACE FLOOR PLAN (SCALE 1:100)

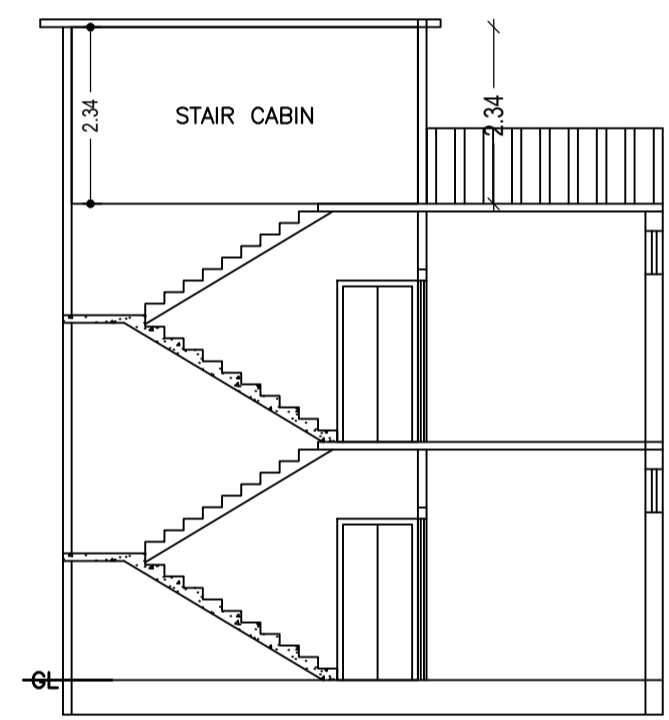
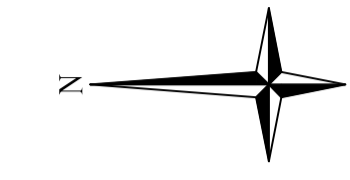

SECTION ON: 'A-A' (SCALE - 1:100)

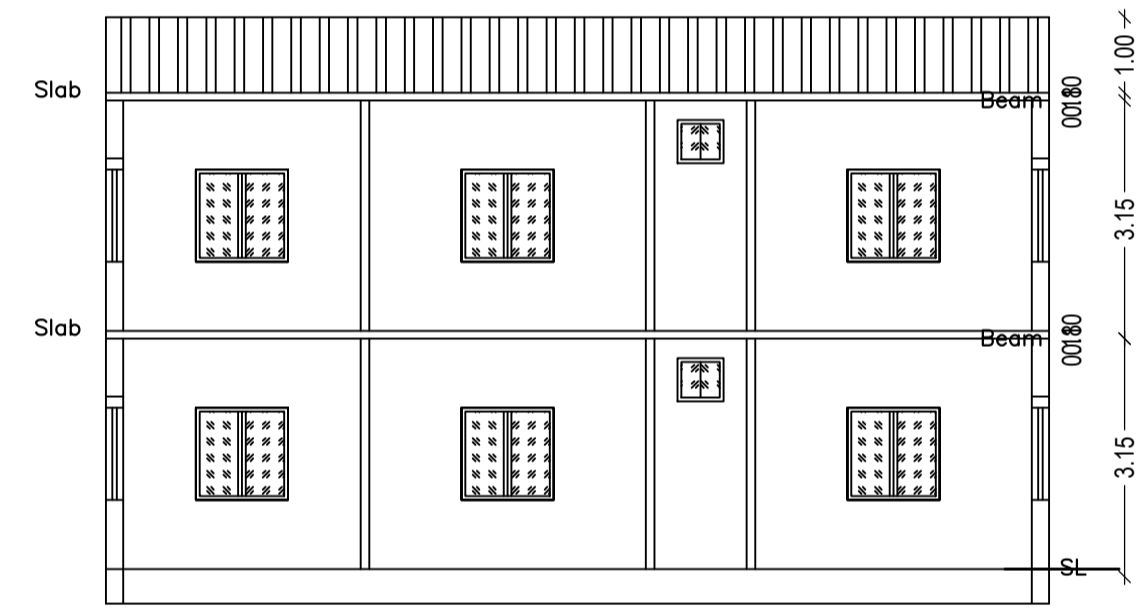

SECTION ON: 'B-B' (SCALE - 1:100)

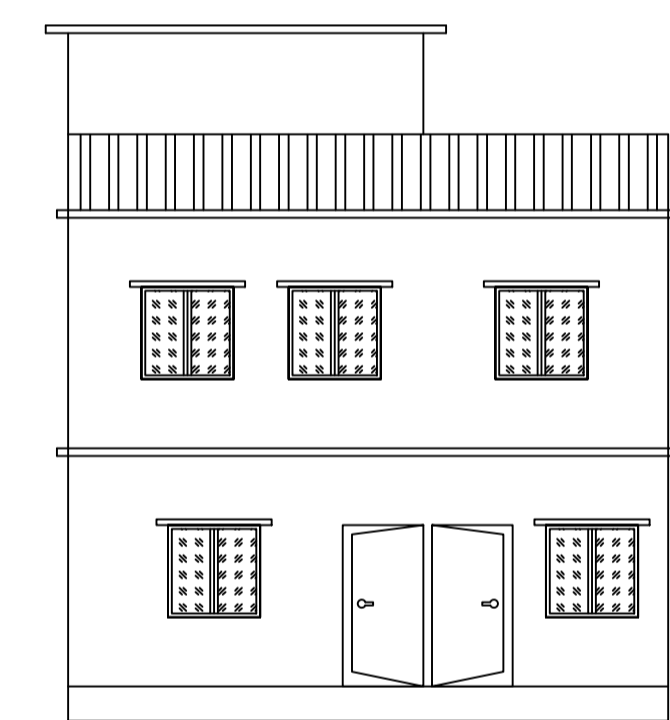

FRONT ELEVATION (SCALE - 1:100)

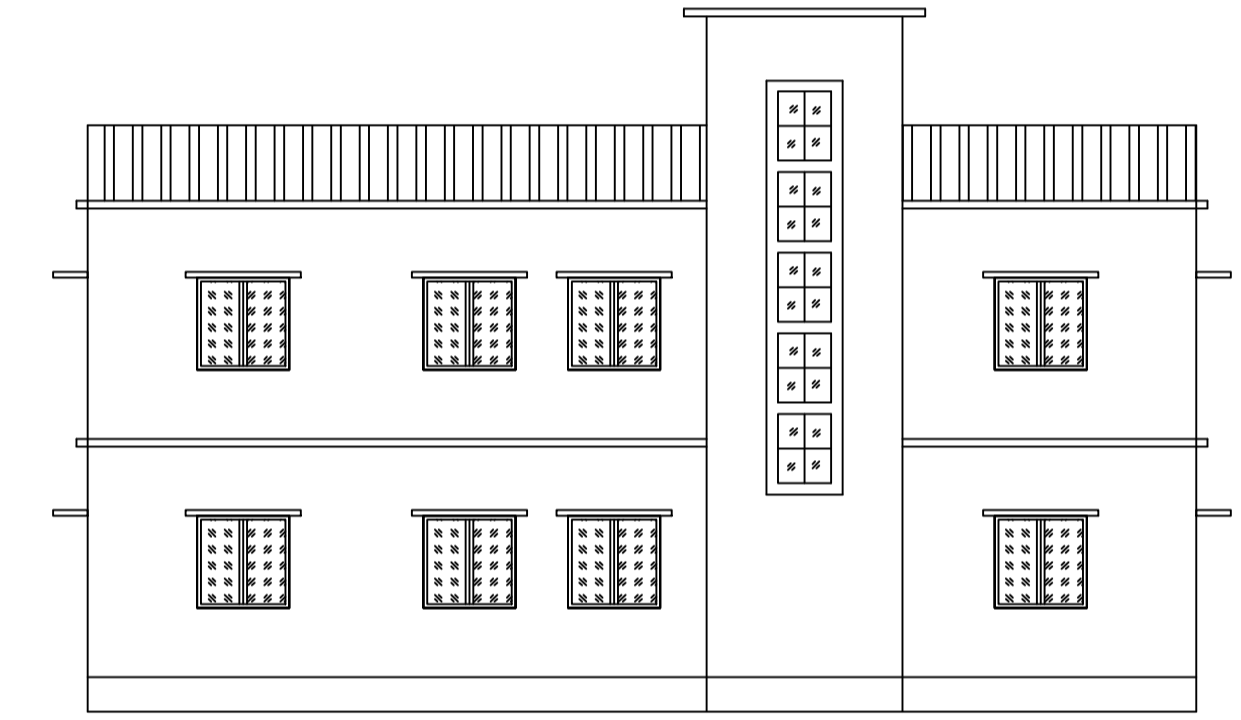

LEFT SIDE ELEVATION (SCALE - 1:100)

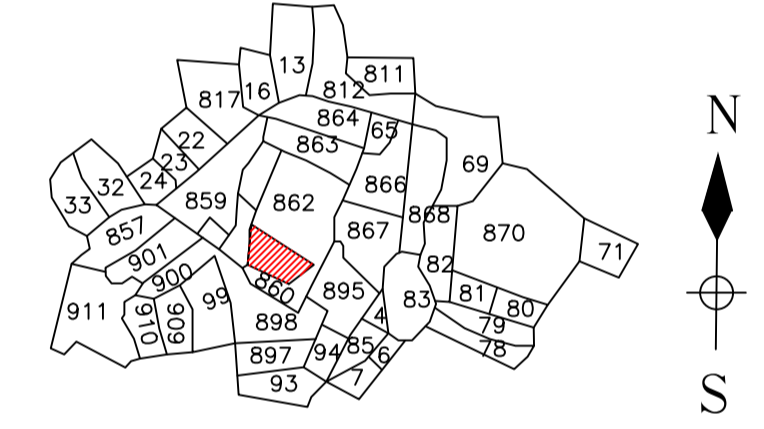

KEY PLAN (SCALE - NTS)

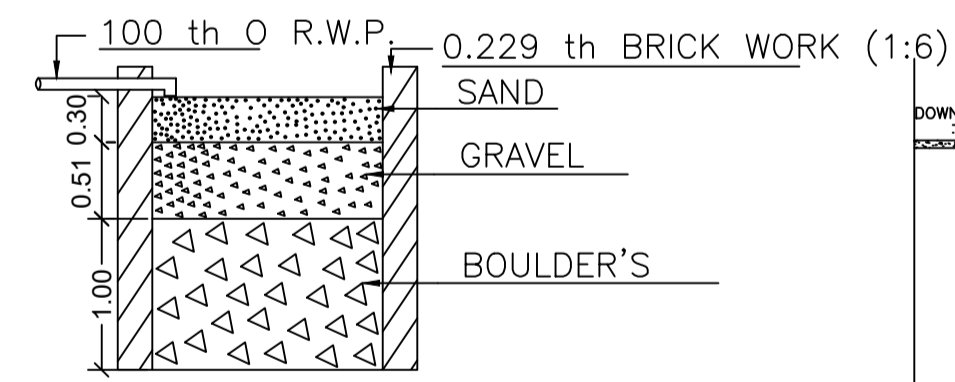

SECTION ON - 'X X' (SCALE - 1:50)

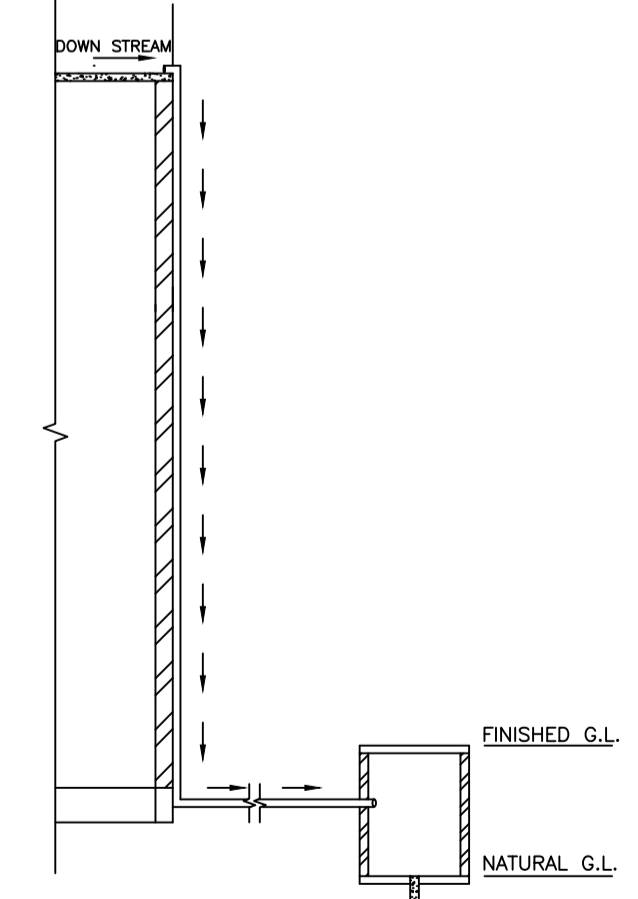

ROOF TOP RAIN WATER COLLECTION SYSTEM (SCALE: 1:96 (1\"/>

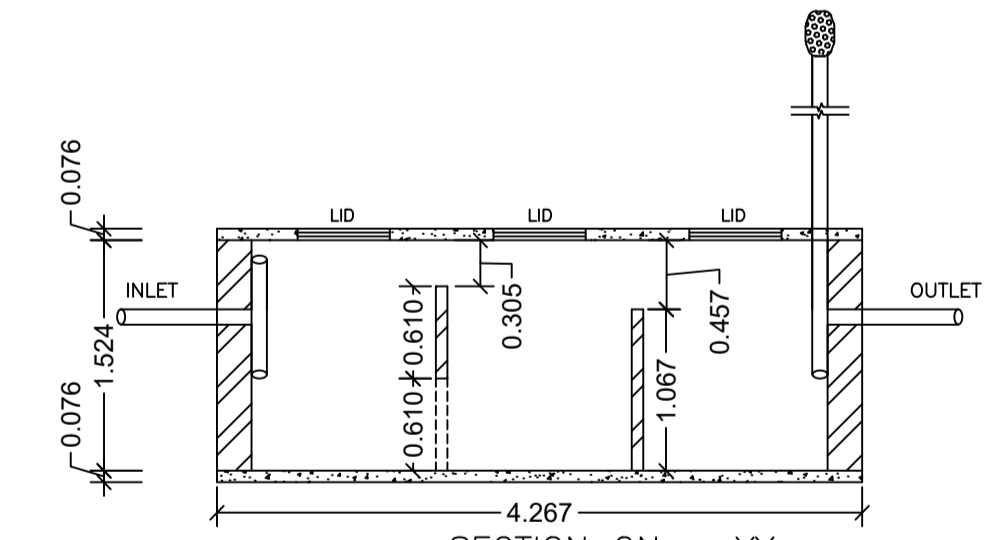

SECTION ON - YY (SCALE - 1:50)

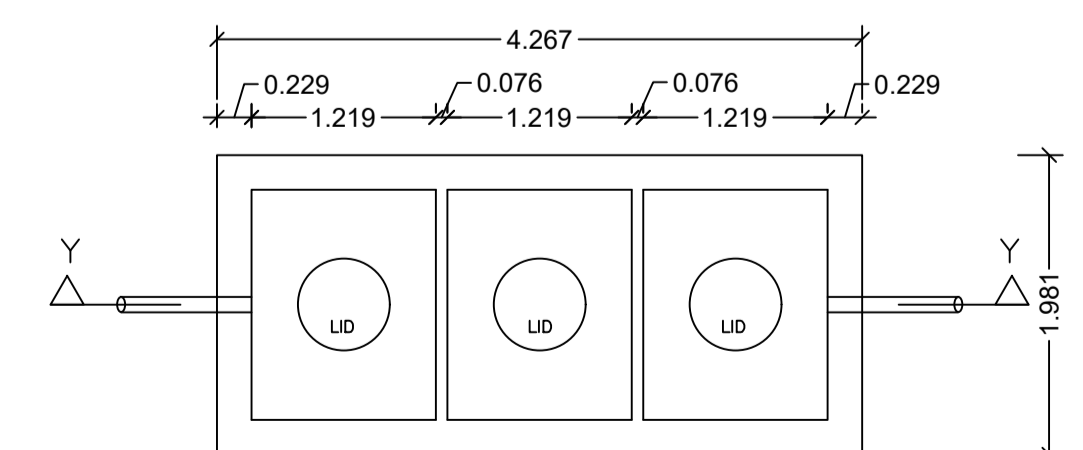

DETAILS OF SEPTIC TANK (SCALE - 1:50)

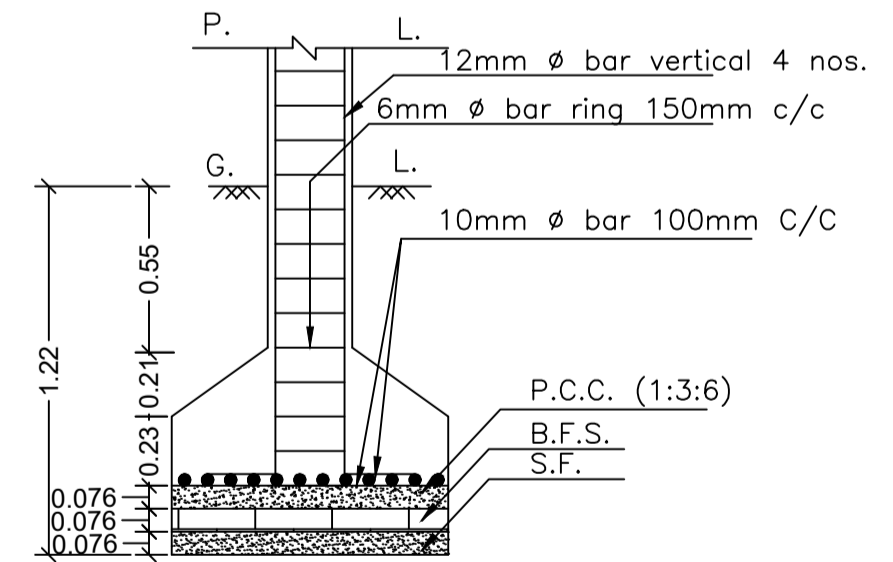

SECTION ON - ZZ (SCALE - 1:25)

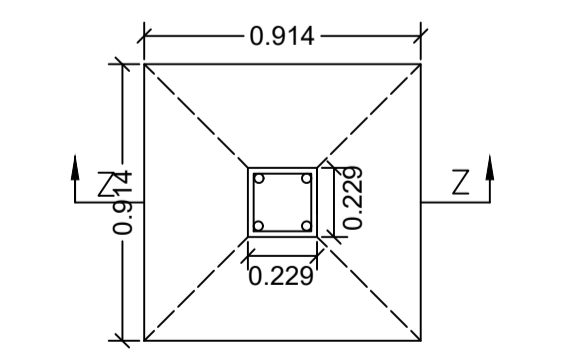

PLAN DETAILS OF COLUMN FOOTING (SCALE - 1:25)

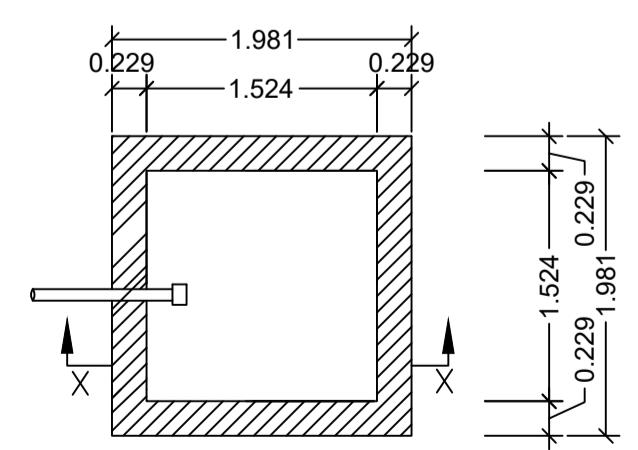

PLAN DETAILS OF WATER HARVESTING (SCALE - 1:50)

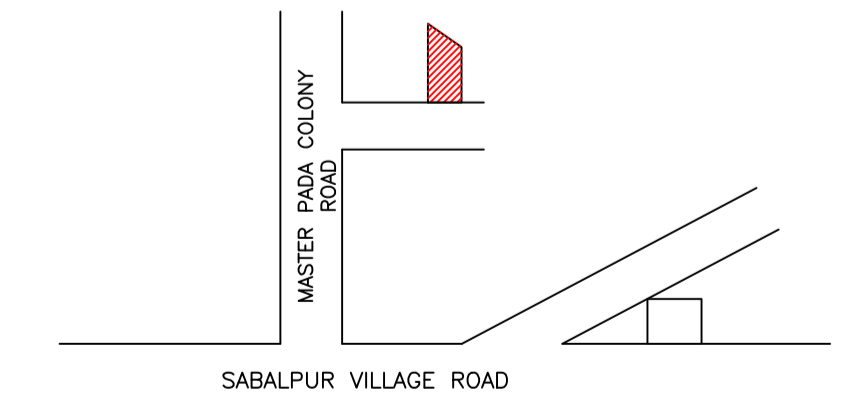

LOCATION

LTP NAME AND SIGNATURE	STRUCTURAL ENG'S NAME AND SIGNATURE	BUILDER NAME AND SIGNATURE	DIGITAL SIGNATURE
Lalan Prasad Singh MADA/ENG/0001/2020			