

Proposal Basic Information

Proposal File No.	MADA/BP/0227/2023
Owner Name	Pankaj Kumar Saw and Manisa Kumari
Khata No	12 (NEW-306)
Plot No	475 (new-617)
Village Name	Damodarpur
Use	Residential
SubUse	Bungalow/ Dwelling / Non Apartment

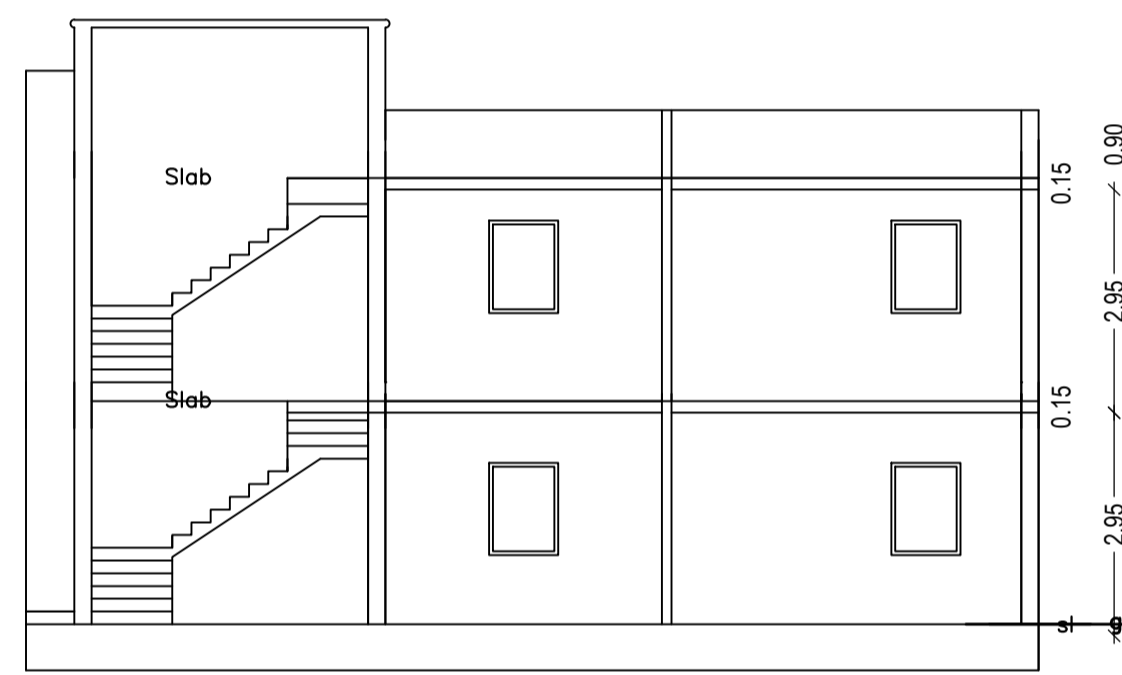

SITE PLAN

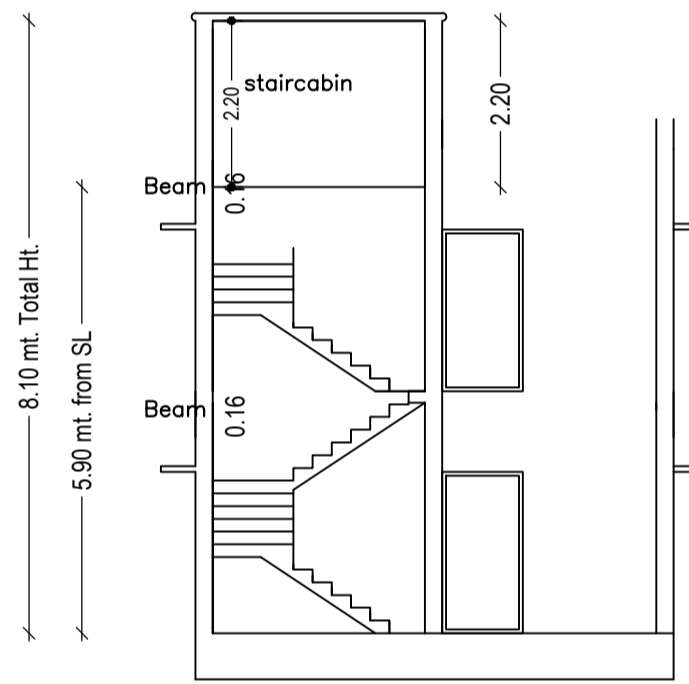
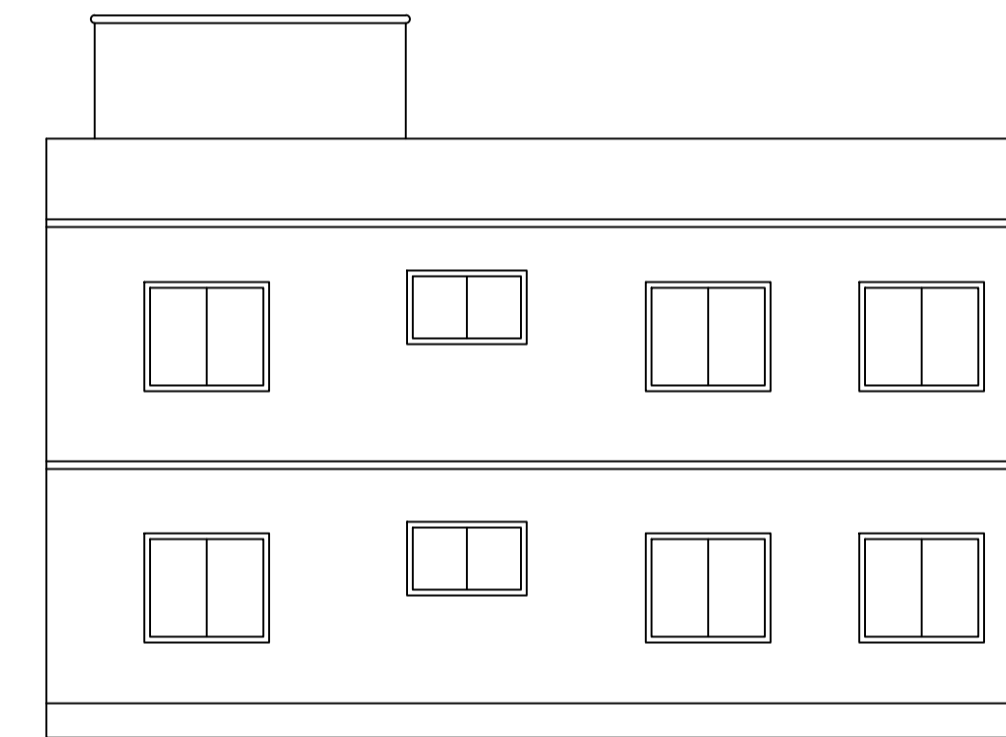
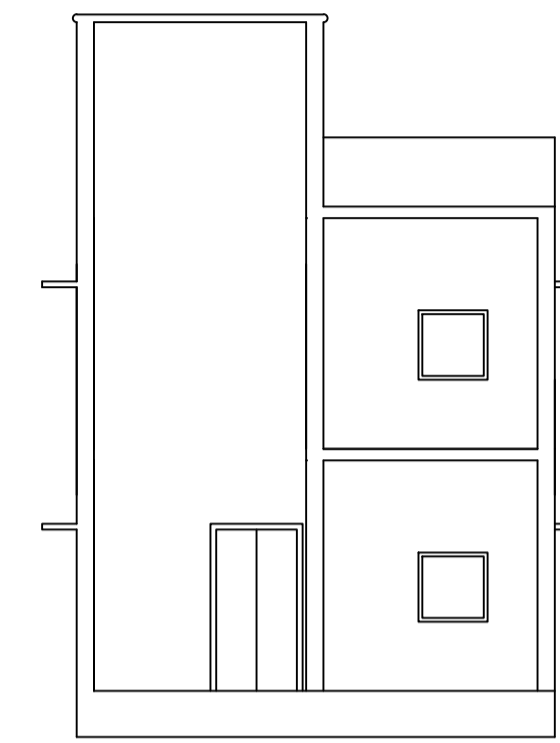
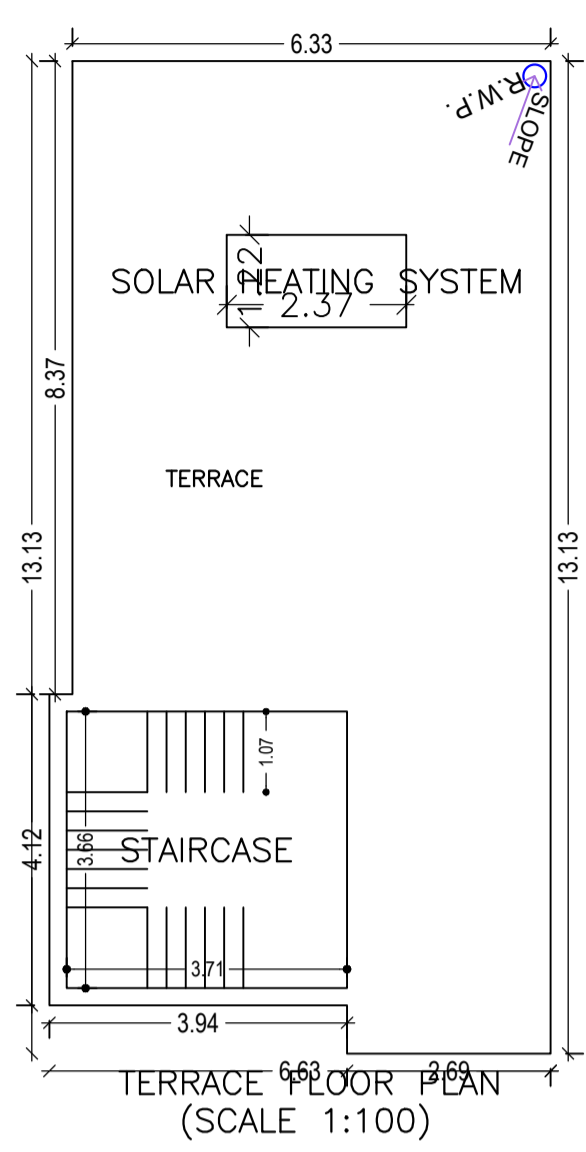
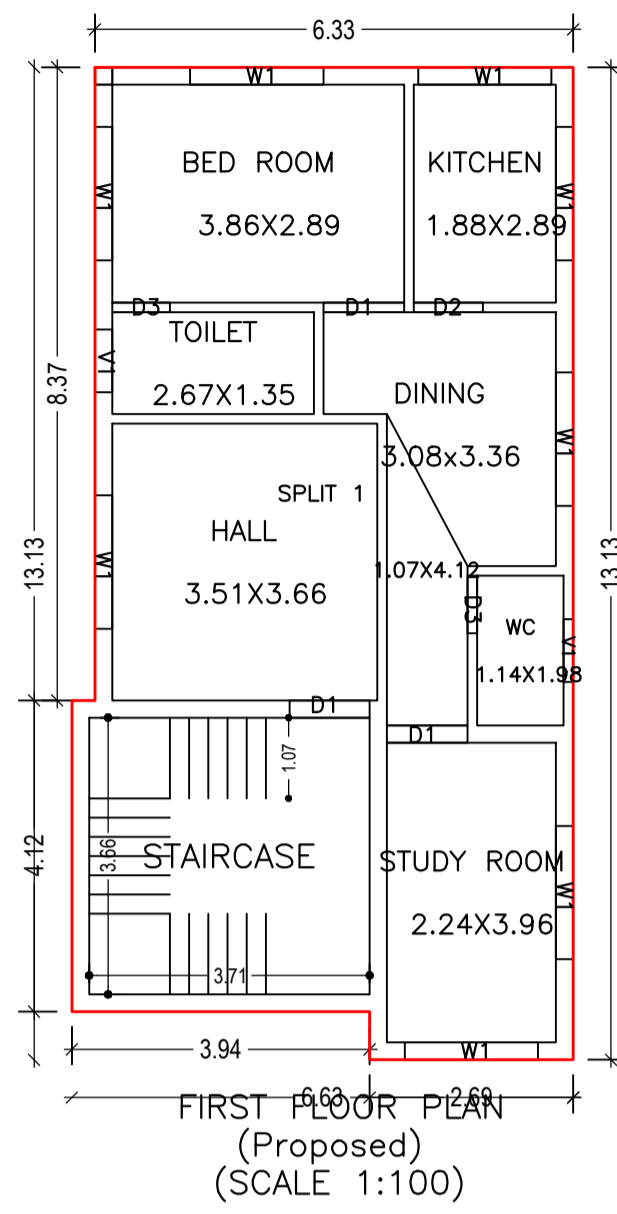
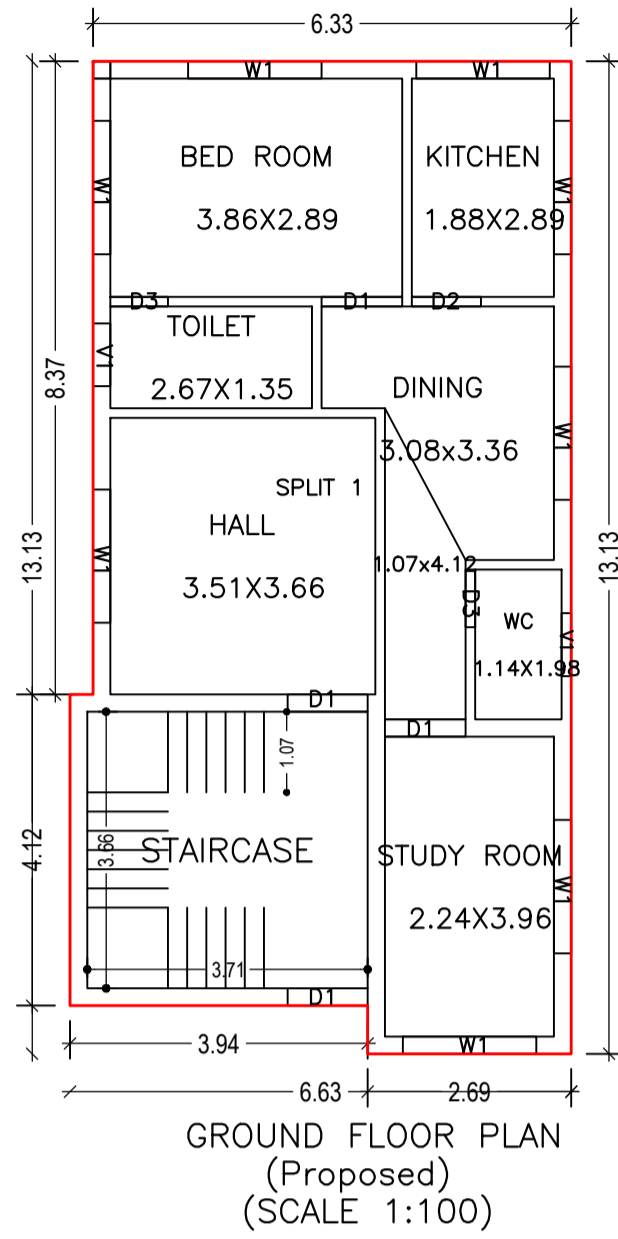
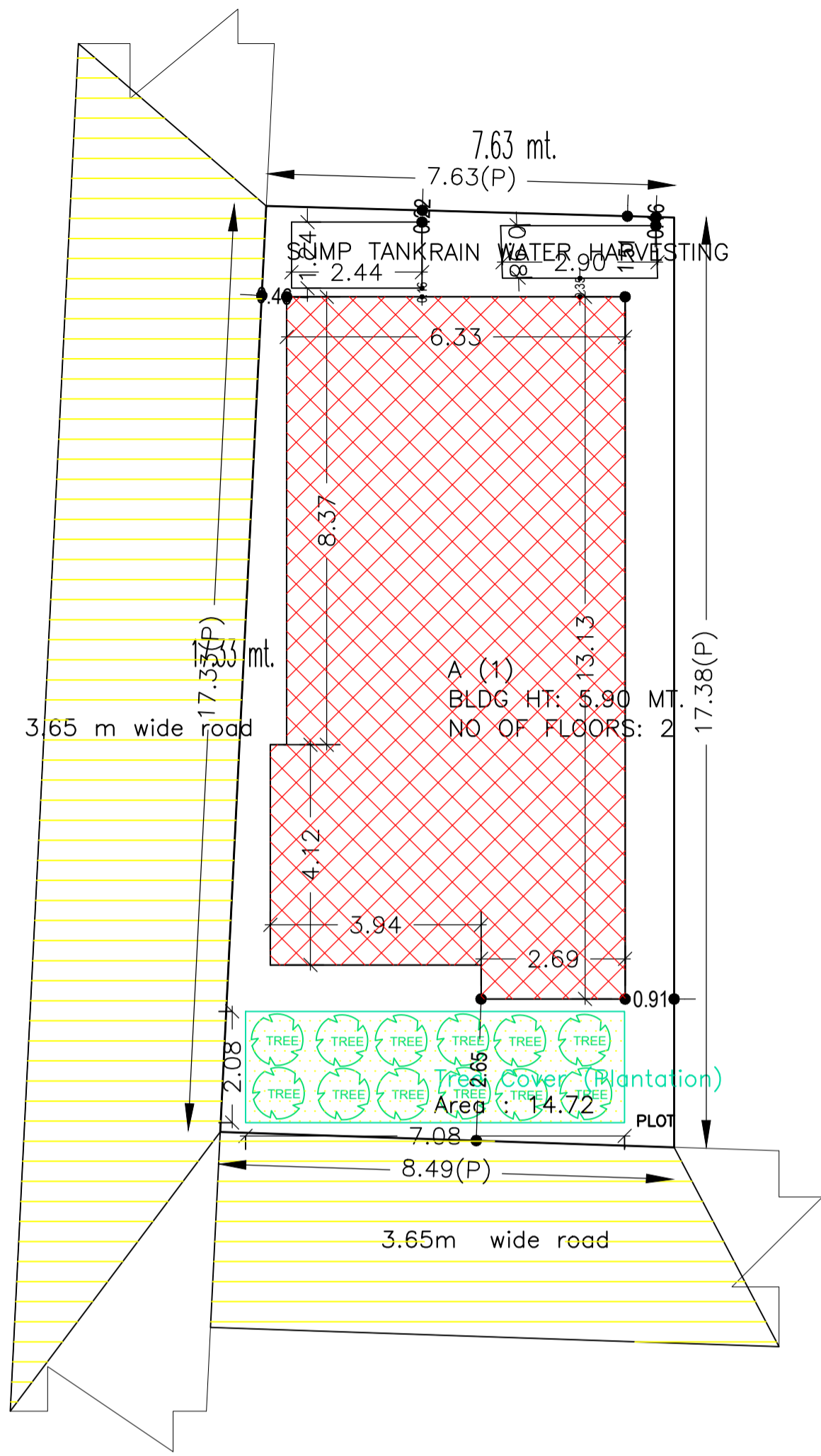
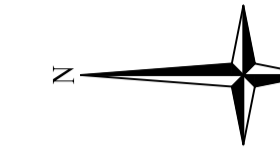
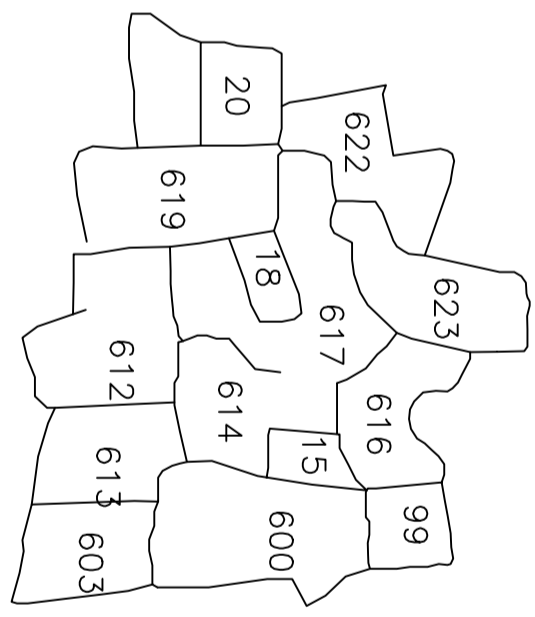

Building :A (1)

Floor Name	Total Built Up Area (Sq.mt.)	Proposed FAR Area (Sq.mt.) Resi.	Total FAR Area (Sq.mt.)	Total Consumed Additional FAR Area (Sq.mt.)	Tnmt (No.)
Ground Floor	81.99	81.99	81.99	81.99	01
First Floor	81.99	81.99	81.99	81.99	00
Terrace Floor	0.00	0.00	0.00	0.00	00
Total :	163.98	163.98	163.98	163.98	01
Total Number of Same Buildings	1				
Total :	163.98	163.98	163.98	163.98	01

SCHEDULE OF DOOR:

BUILDING NAME	NAME	LENGTH	HEIGHT	NOS
A (1)	D3	0.76	2.10	04
A (1)	D2	0.91	2.10	02
A (1)	D1	1.06	2.10	02
A (1)	D1	1.07	2.10	04

SCHEDULE OF WINDOW/VENTILATION:

BUILDING NAME	NAME	LENGTH	HEIGHT	NOS
A (1)	V1	0.83	0.60	04
A (1)	W1	1.76	1.20	16

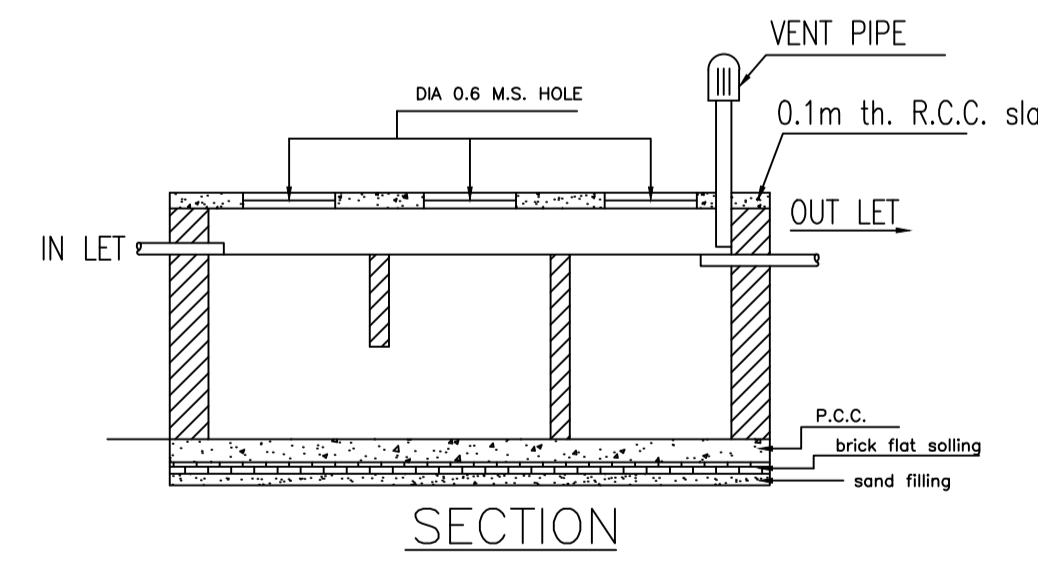
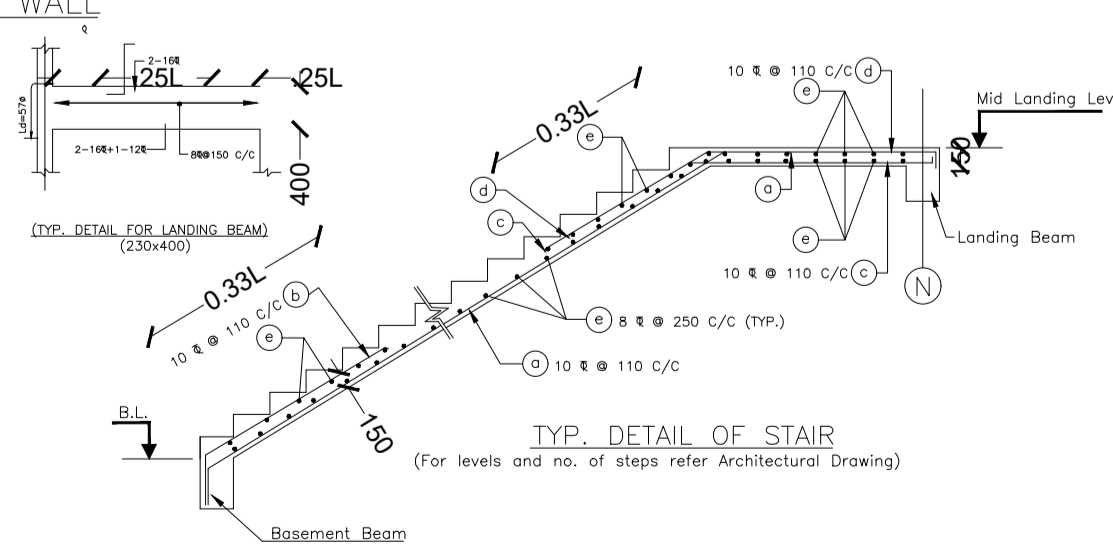
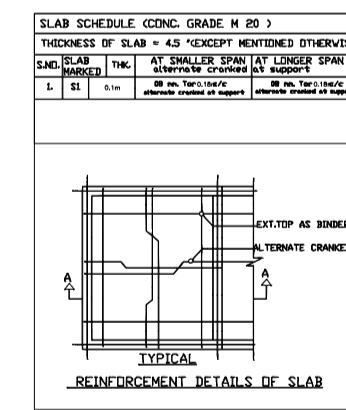
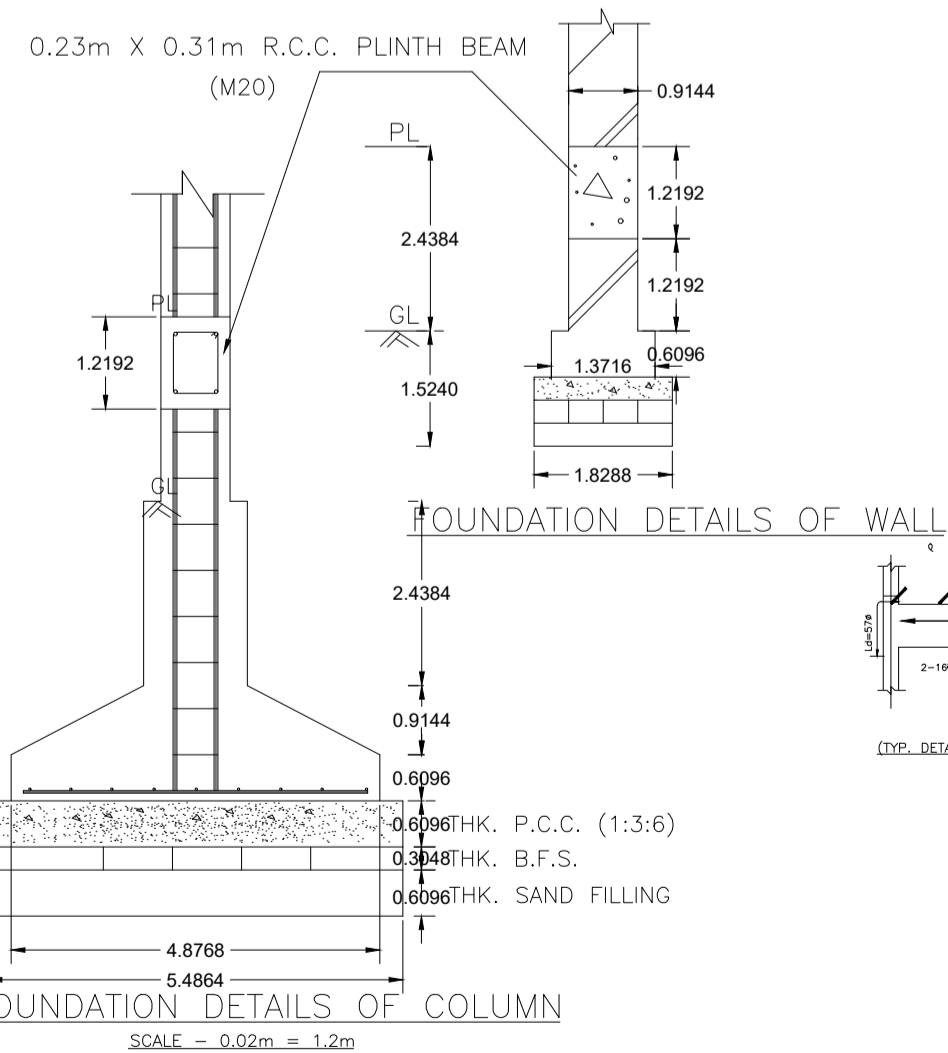

DETAILS OF SEPTIC TANK

AREA STATEMENT MINERAL AREA DEVELOPMENT AUTHORITY	VERSION NO.: 1.0.66 VERSION DATE: 16/10/2020
PROJECT DETAIL:	
Region: JHARKHAND URBAN LOCAL BODIES	Plot Use: Residential
District: DHANBAD	Plot SubUse: Bungalow/ Dwelling / Non Apartment
Authority: MINERAL AREA DEVELOPMENT AUTHORITY	PlotNearby/ReligiousStructure: NA
Inward No: MADA/BP/0227/2023	Plot/SubPlot No: 475 (new-617)
Application Type: General Proposal	North: Road Width - 3.65
Project Type: Building Permission	South: Plot No. - 614
Nature of Development: New	East: Plot No. - Part of plot no. 617
Location of Development Area: Old Area	West: Road Width - 3.66
AREA DETAILS:	
AREA OF PLOT (Minimum)	(A) 139.79
NET AREA OF PLOT (Gross Plot Area - Deduction from Gross Plot area)	(A-Deductions) 139.79
Deduction for Balance Plot Area (from Gross Plot Area)	
Common Plot Total	14.72
BALANCE AREA OF PLOT (Net Plot Area - Recreational/Amenity space)	(A-Deductions) 125.07
PLOT AREA FOR COVERAGE (Net Plot Area)	(A-Deductions) 139.79
Plot Area for FAR (Net Plot Area + Road Widening Area)	(A-Deductions) 139.79
COVERAGE CHECK	
Permissible Coverage area (70.00 %)	97.85
Proposed Coverage Area (58.65 %)	81.99
Total Prop. Coverage Area (58.65 %)	81.99
Balance coverage area (11.35 %)	15.86
FAR CHECK	
Perm. FAR Area (1.500)	209.68
Total Perm. FAR area	209.68
Residential FAR	163.99
Proposed FAR Area	163.99
Total Proposed FAR Area	163.99
Consumed FAR (Factor)	1.17
Balance FAR Area	45.69
BUILT UP AREA CHECK	
Total Proposed BuiltUp Area	163.98
ARCHITECT (Regd)	Sushil Kumar
ENGINEER (Regd)	
SUPERVISOR (Regd)	
OWNER (Regd)	Pankaj Kumar Saw and Manisa Kumari
DEVELOPMENT AUTHORITY LOCAL BODY	

Color	Meaning
Black	PLOT BOUNDARY
Red	ABUTTING ROAD
Green	PROPOSED CONSTRUCTION
Yellow	COMMON PLOT
Blue	ROAD WIDENING AREA
Orange	EXISTING (To be retained)
Purple	EXISTING (To be demolished)

Buildingwise Floor FAR Details

Floor Name	Building Name A (1)		Total	
	Proposed Built Up Area (Sq.mt.)	Proposed FAR Area (Sq.mt.)	Total Proposed Built Up Area (Sq.mt.)	Total FAR Area (Sq.mt.)
Ground Floor	81.99	81.99	81.99	81.99
First Floor	81.99	81.99	81.99	81.99
Terrace Floor	0.00	0.00	0.00	0.00
Total :	163.98	163.98	163.98	163.98

Building USE/SUBUSE Details

Building Name	Building Use	Building SubUse	Building Structure
A (1)	Residential	Bungalow/ Dwelling / Non Apartment	Non-Highrise

FAR & Tenement Details (Table 4c-1)

Building	No. of Same Bldg	Total Built Up Area (Sq.mt.)	Proposed FAR Area (Sq.mt.) Resi.	Total FAR Area (Sq.mt.)	Total Consumed Additional FAR Area (Sq.mt.)	Trmt (No.)
A (1)	1	163.98	163.98	163.98	163.98	01
Grand Total :	1	163.98	163.98	163.98	163.98	01

UnitBUA Table for Building :A (1)

FLOOR	Name	UnitBUA Type	UnitBUA Area	Carpet Area	No. of Rooms	No. of Tenement
GROUND FLOOR PLAN	SPLIT 1	FLAT	163.99	163.88	7	1
FIRST FLOOR PLAN	SPLIT 1	FLAT	0.00	0.00	7	0
Total:	-	-	163.99	163.88	14	1

LTP NAME AND SIGNATURE	STRUCTURAL ENG'S NAME AND SIGNATURE	BUILDER NAME AND SIGNATURE	DIGITAL SIGNATURE
Sushil Kumar MADA/ENG/0009/2019			

Proposal Basic Information	
Proposal File No.	MADA/BP/0227/2023
Owner Name	Pankaj Kumar Saw and Manisa Kumari
Khata No	12 (NEW-306)
Plot No	475 (new-617)
Village Name	Damodarapur
Use	Residential
SubUse	Bungalow/ Dwelling / Non Apartment

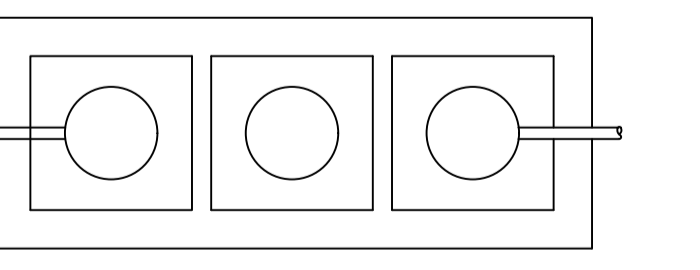
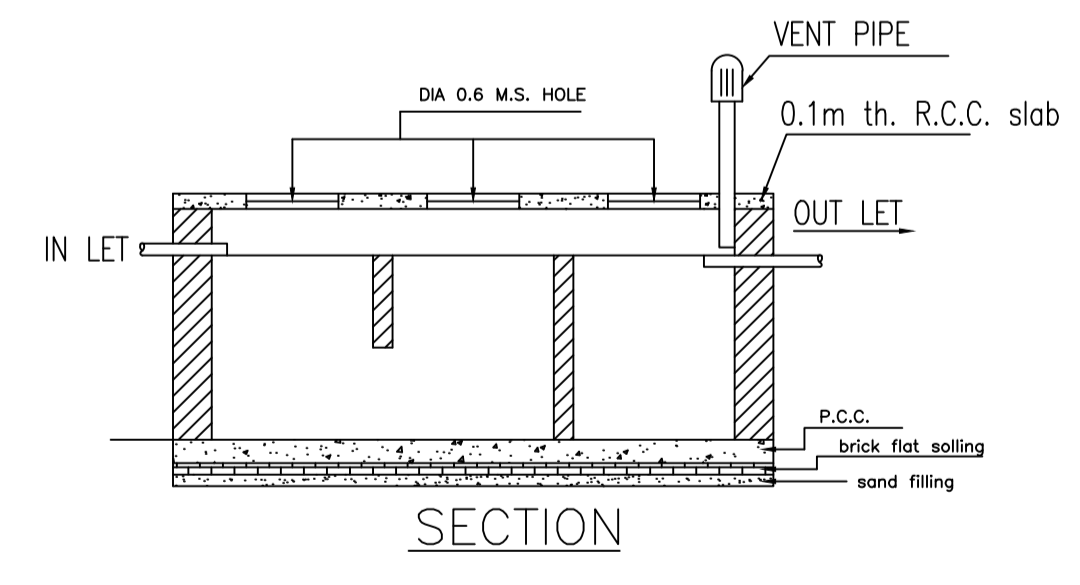
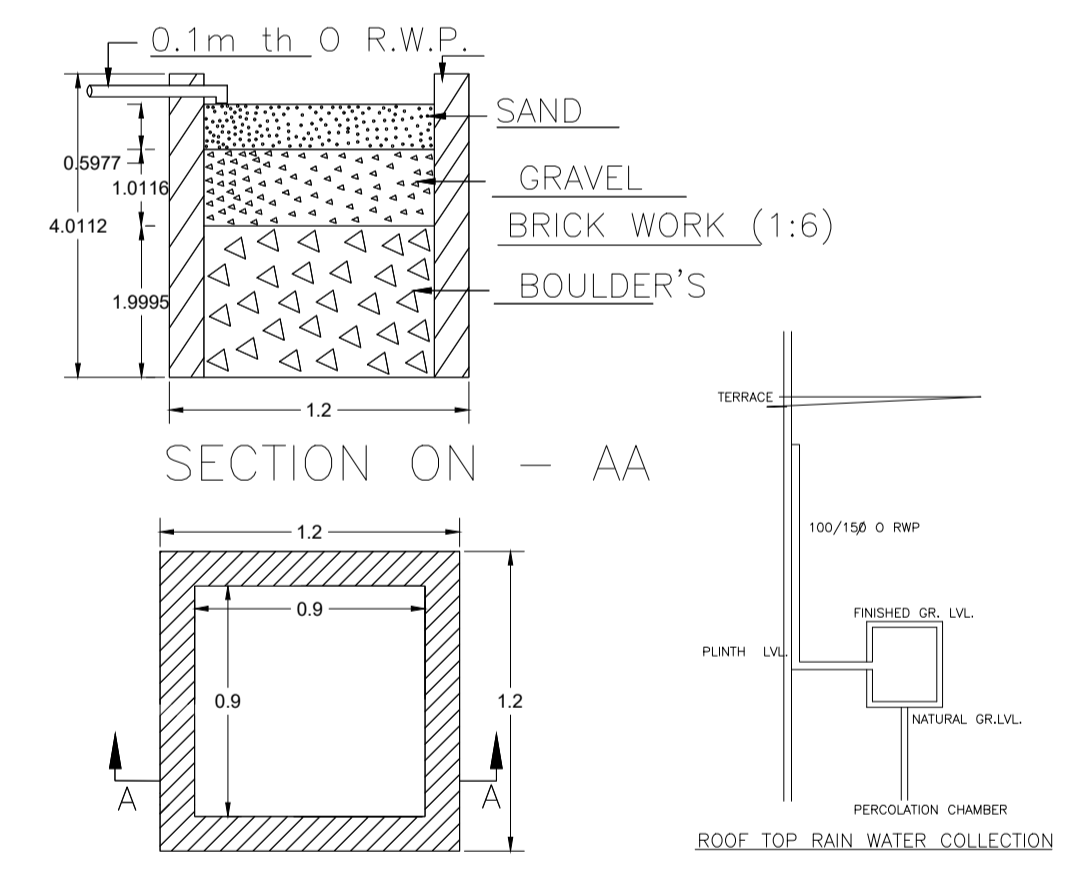
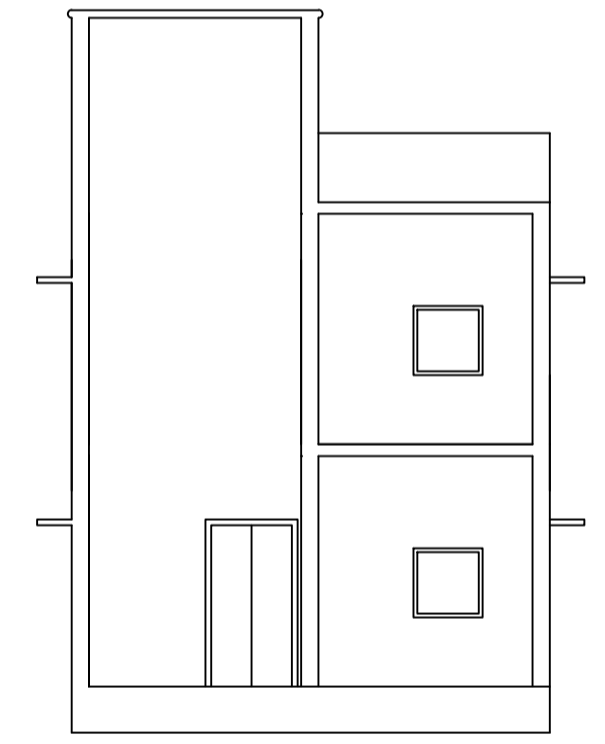
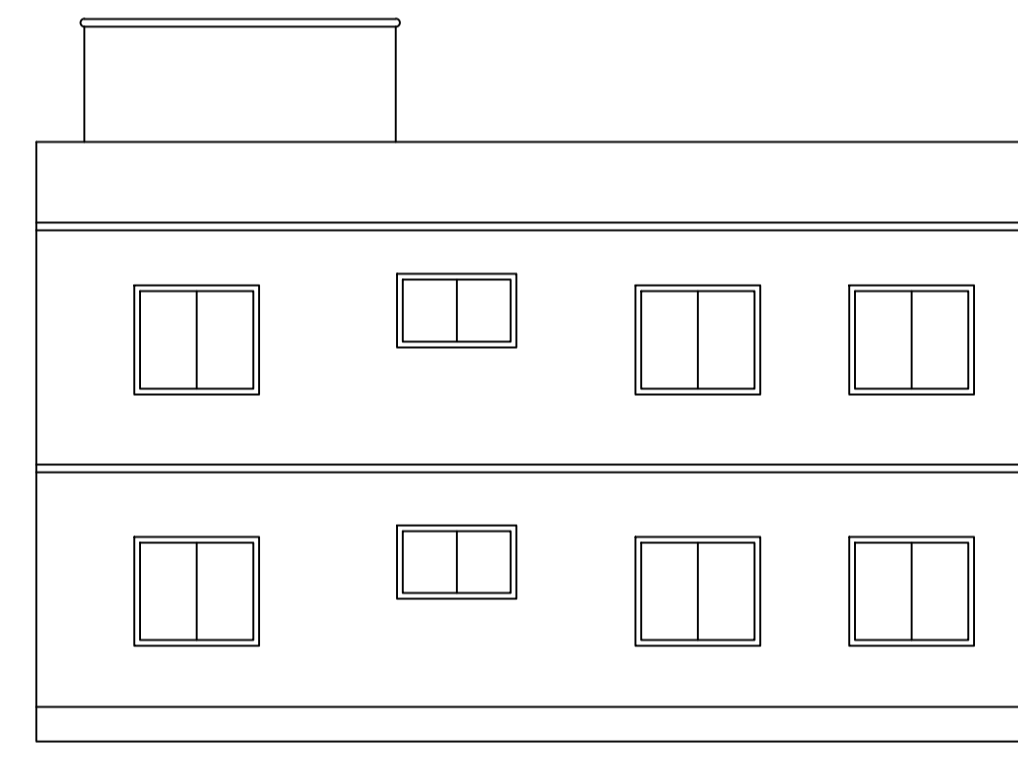
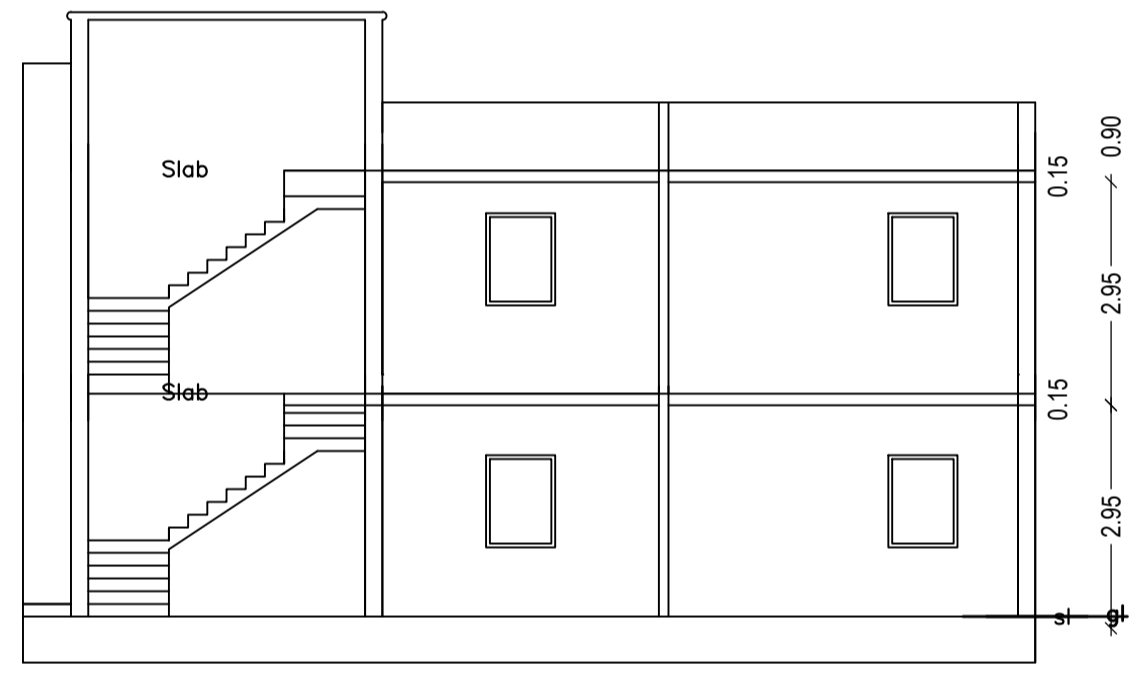
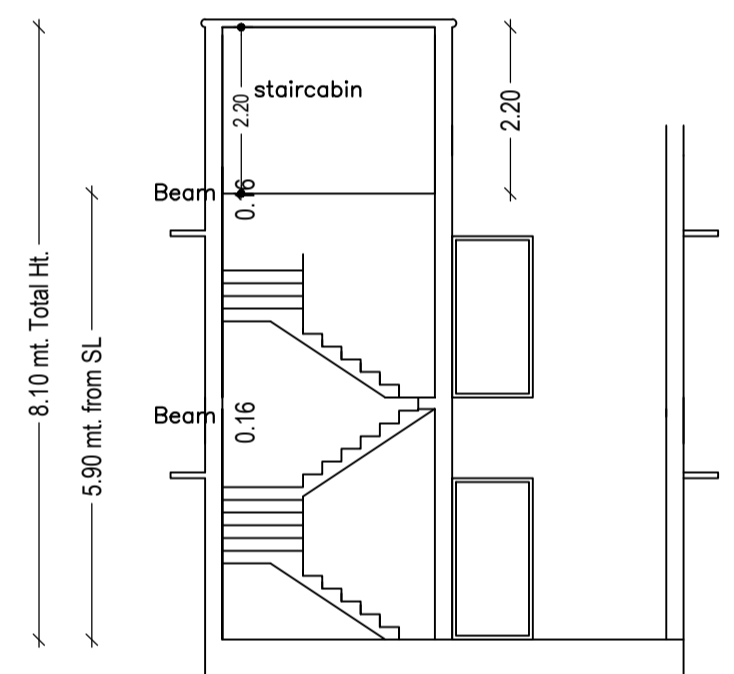
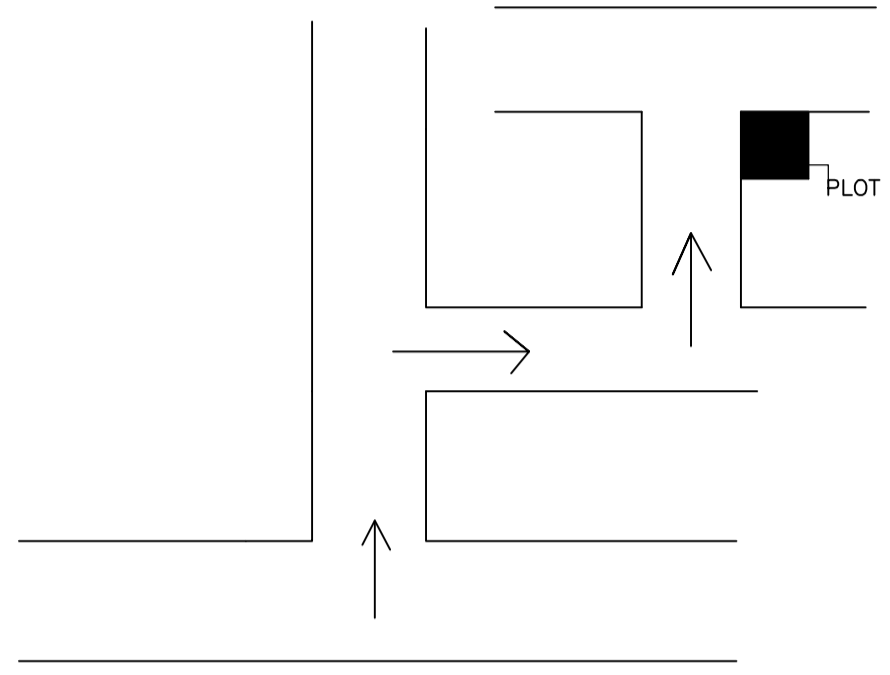
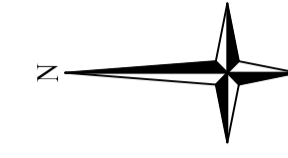
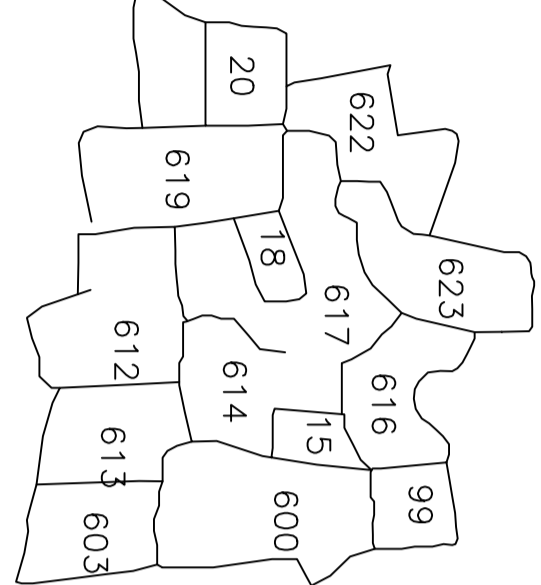
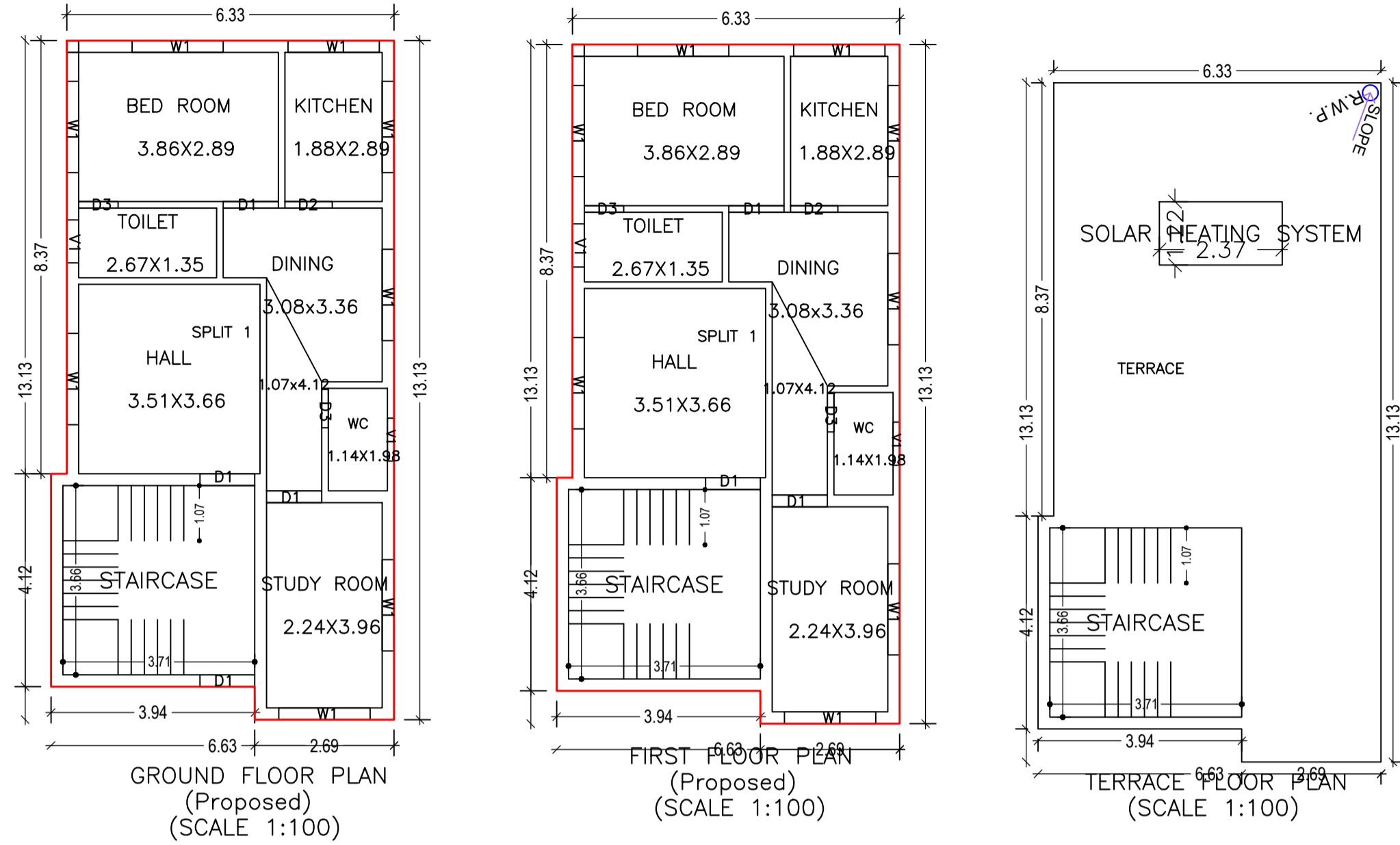

DETAILS OF SEPTIC TANK

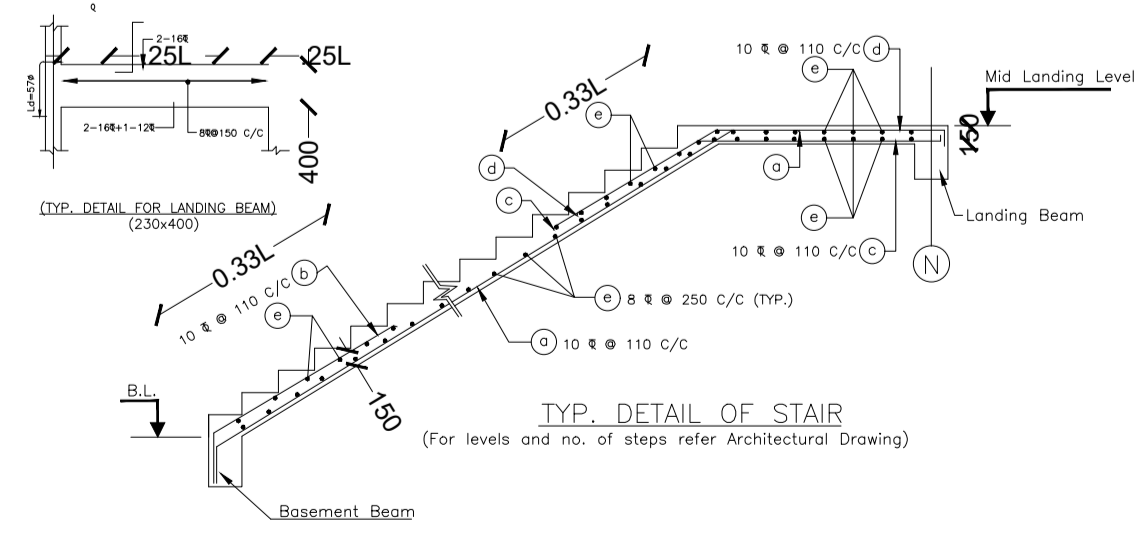
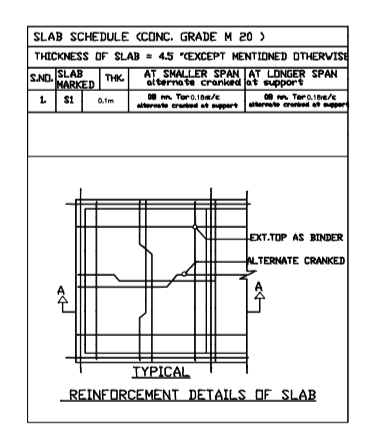
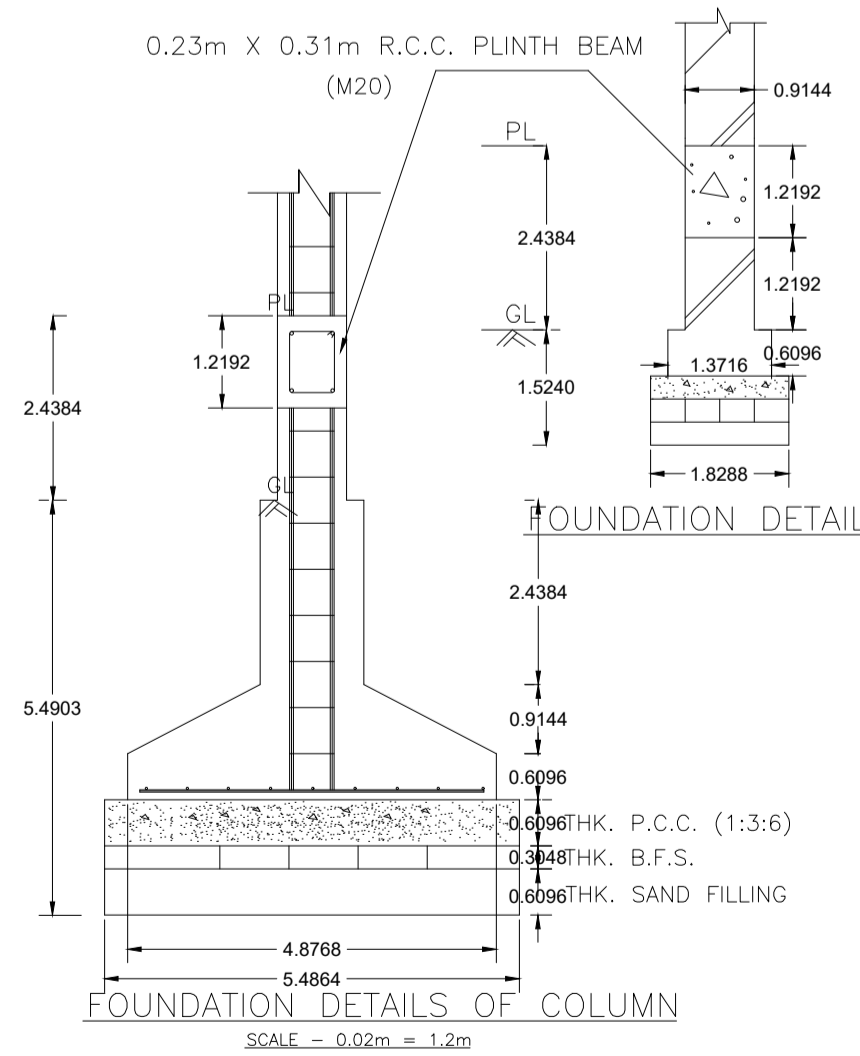

DETAIL'S OF WATER HARVESTING

LTP NAME AND SIGNATURE	STRUCTURAL ENG'S NAME AND SIGNATURE	BUILDER NAME AND SIGNATURE	DIGITAL SIGNATURE
Sushil Kumar MADA/ENG/0009/2019			