

LEFT SIDE ELEVATION

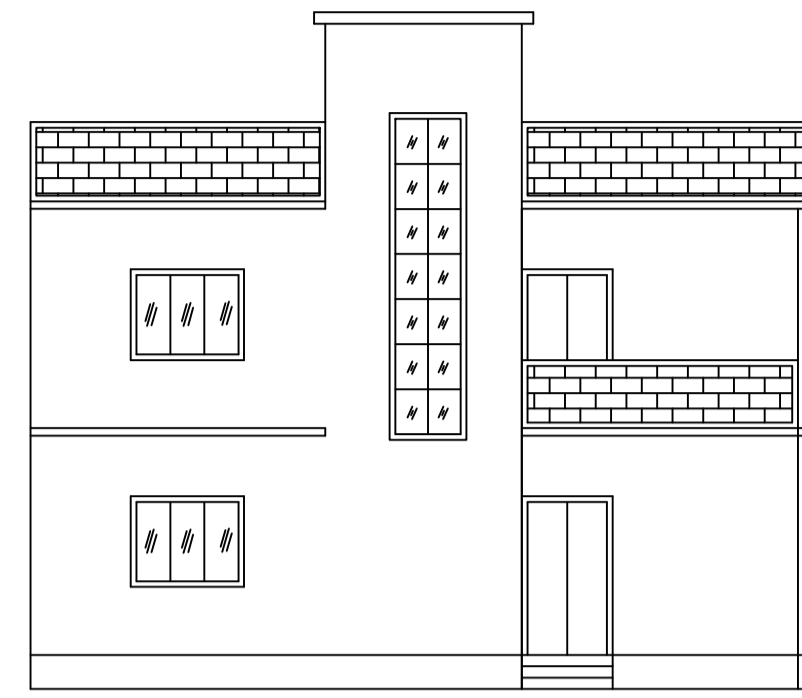

FRONT ELEVATION

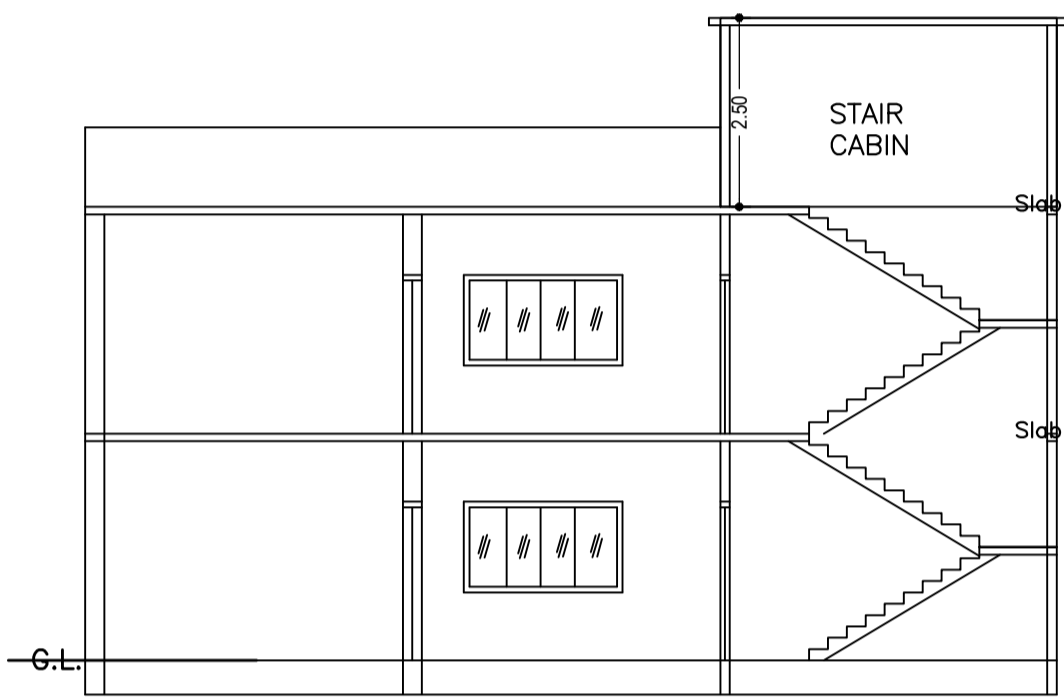

SECTION ON X-X

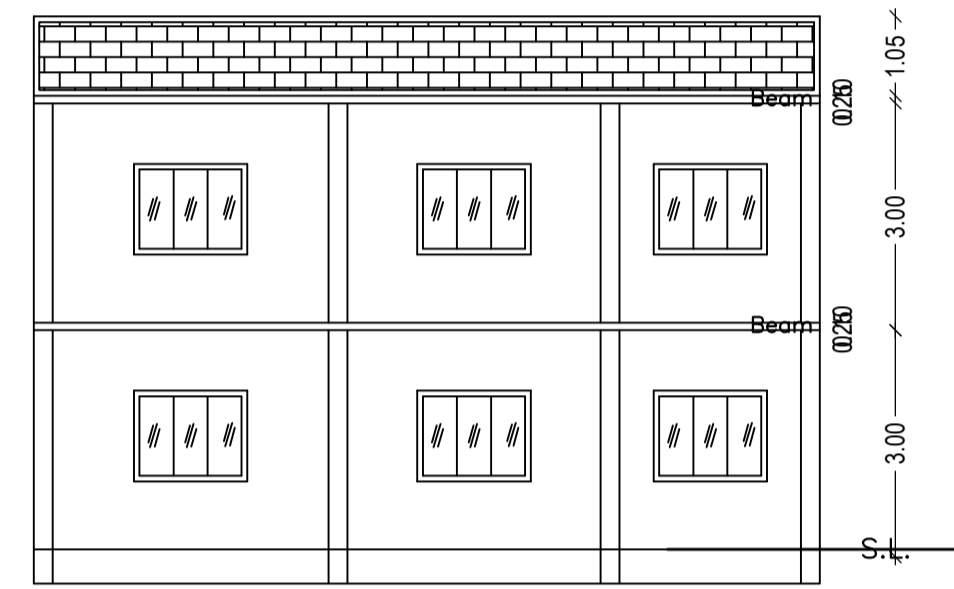

SECTION ON Y-Y

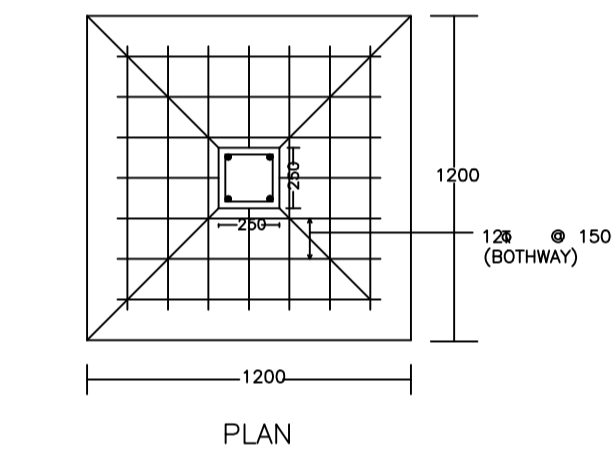
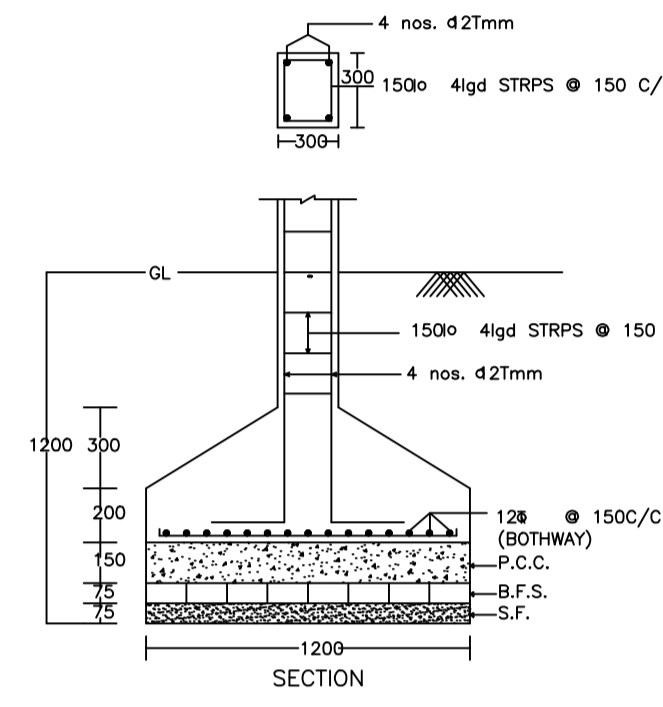

DETAIL OF COLUMNS

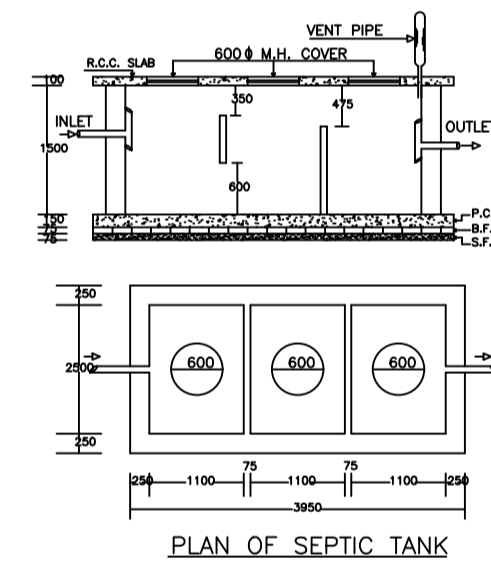

PLAN OF SEPTIC TANK

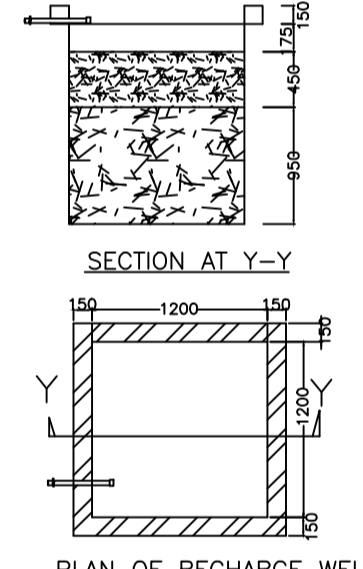

SECTION AT Y-Y

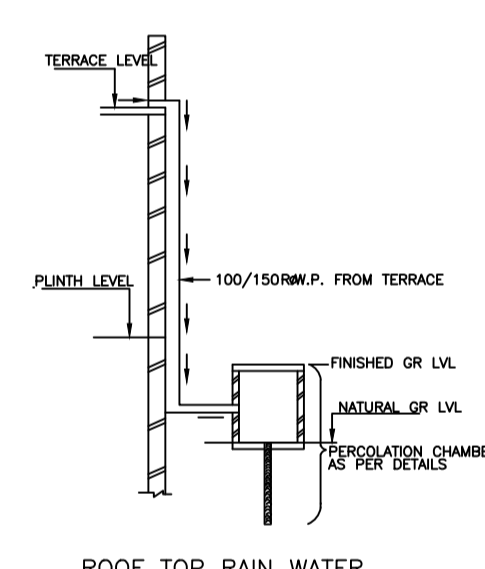

PLAN OF RECHARGE WELL

ROOF TOP RAIN WATER COLLECTION SYSTEM

SITE PLAN

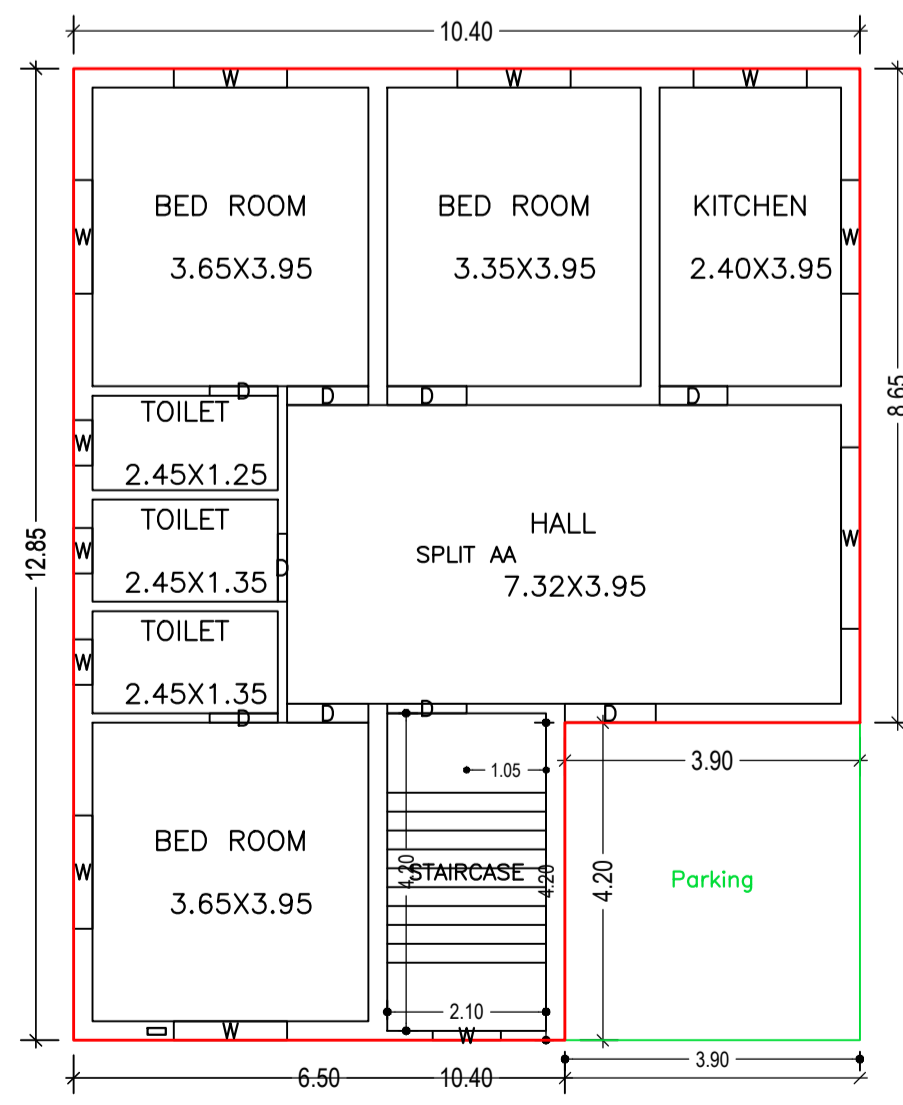

GROUND FLOOR PLAN (Proposed) (SCALE 1:100)

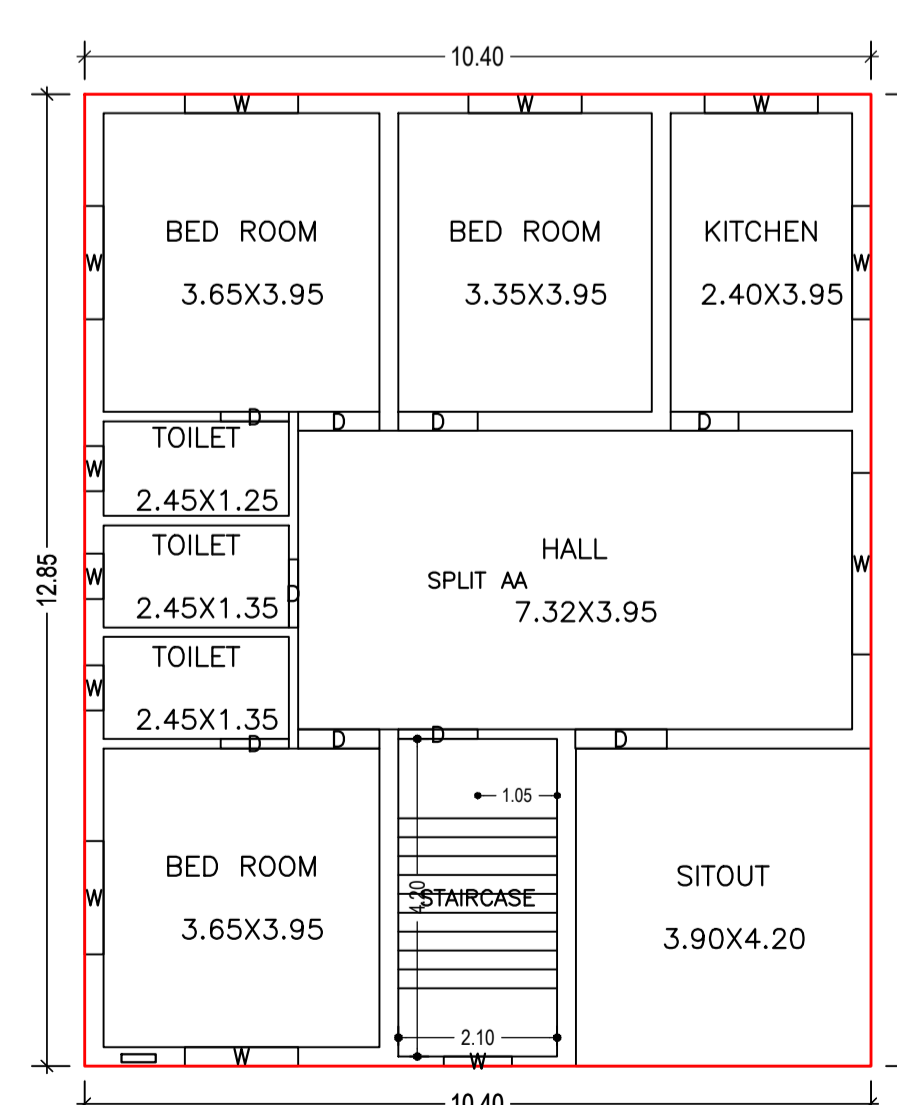

FIRST FLOOR PLAN (Proposed) (SCALE 1:100)

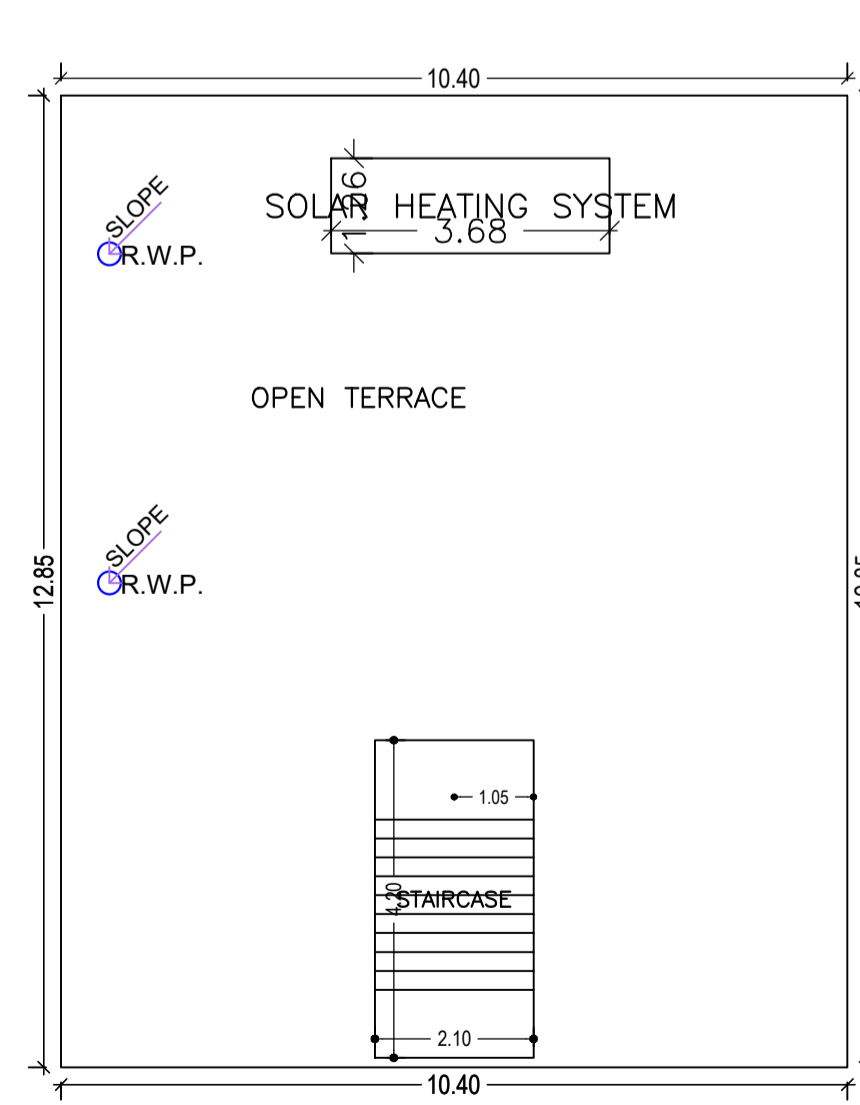

TERRACE FLOOR PLAN (SCALE 1:100)

Building :AA (AA)

Floor Name	Total Built Up Area (Sq.mt.)	Deductions (Area in Sq.mt.)	Proposed FAR Area (Sq.mt.)	Total FAR Area (Sq.mt.)	Total Consumed Additional FAR Area (Sq.mt.)	Tnmt (No.)
Ground Floor	133.64	16.38	117.26	117.26	117.26	01
First Floor	133.64	0.00	133.64	133.64	133.64	00
Terrace Floor	0.00	0.00	0.00	0.00	0.00	00
Total :	267.28	16.38	250.90	250.90	250.90	01
Total Number of Same Buildings :	1					
Total :	267.28	16.38	250.90	250.90	250.90	01

SCHEDULE OF DOOR:

BUILDING NAME	NAME	LENGTH	HEIGHT	NOS
AA (AA)	D	0.90	2.10	08
AA (AA)	D	1.05	2.10	04
AA (AA)	D	1.08	2.10	04
AA (AA)	D	1.20	2.10	01
AA (AA)	D	1.21	2.10	01

SCHEDULE OF WINDOW/VENTILATION:

BUILDING NAME	NAME	LENGTH	HEIGHT	NOS
AA (AA)	W	0.60	1.20	06
AA (AA)	W	0.90	1.20	02
AA (AA)	W	1.50	1.20	14
AA (AA)	W	2.40	1.20	02

UnitBUA Table for Building :AA (AA)

FLOOR	Name	UnitBUA Type	UnitBUA Area	Carpet Area	No. of Rooms	No. of Tenement
GROUND FLOOR PLAN	SPLIT AA	FLAT	250.90	250.83	8	1
FIRST FLOOR PLAN	SPLIT AA	FLAT	0.00	0.00	9	0
Total:	-	-	250.90	250.83	17	1

AREA STATEMENT MINERAL AREA DEVELOPMENT AUTHORITY	VERSION NO.: 1.0.66	VERSION DATE: 16/10/2020
PROJECT DETAIL:		
Region: JHARKHAND URBAN LOCAL BODIES	Plot Use: Residential	
District: DHANBAD	Plot SubUse: Bungalow/ Dwelling / Non Apartment	
Authority: MINERAL AREA DEVELOPMENT AUTHORITY	Plot/Nearby/Religious/Structure: NA	
Inward No: MADA/BP0241/2023	Plot/SubPlot No: 27(OLD),43(NEW)	
Application Type: General Proposal	North: Road Width - 4.87	
Project Type: Building Permission	South: Plot No. - PLOT NO. 26	
Nature of Development: New	East: Plot No. - PLOT NO. 26	
Location of Development Area: Old Area	West: Plot No. - LEKHAKARI NIZ	
AREA DETAILS:		
AREA OF PLOT (Minimum)	(A)	343.44
Deduction for NetPlot Area		
Surrender Free of Cost		1.58
Total		1.58
NET AREA OF PLOT(Gross Plot Area - Deduction from Gross Plot area)	(A-Deductions)	341.86
Deduction for Balance Plot Area(from Gross Plot Area)		
Surrender Free of Cost		1.58
Common Plot		57.38
Total		58.96
BALANCE AREA OF PLOT(Net Plot Area - Recreational/Amenity space)	(A-Deductions)	284.48
PLOT AREA FOR COVERAGE(Net Plot Area)	(A-Deductions)	341.86
Plot Area for FAR (Net Plot Area + RoadWidening Area)	(A-Deductions)	343.44
COVERAGE CHECK		
Permissible Coverage area (60.00 %)		205.12
Proposed Coverage Area (39.09 %)		133.64
Total Prop. Coverage Area (39.09 %)		133.64
Balance coverage area (20.91 %)		71.48
FAR CHECK		
Perm. FAR Area (1.800)		618.19
Total Perm. FAR area		618.19
Residential FAR		250.90
Proposed FAR Area		250.90
Total Proposed FAR Area		250.90
Consumed FAR (Factor)		0.73
Balance FAR Area		367.29
BUILT UP AREA CHECK		
Total Proposed BuiltUp Area		267.28
ARCHITECT (Regd)	Lalan Prasad Singh	
ENGINEER (Regd)		
SUPERVISOR (Regd)		
OWNER (Regd)	MARCELINA DEVI	
DEVELOPMENT AUTHORITY		LOCAL BODY

COLOR INDEX	
PLOT BOUNDARY	Black
ABUTTING ROAD	Green
PROPOSED CONSTRUCTION	Red
COMMON PLOT	Yellow
ROAD WIDENING AREA	Blue
EXISTING (To be retained)	Light Blue
EXISTING (To be demolished)	Dark Blue

Buildingwise Floor FAR Details

Floor Name	Building Name		Total	
	Proposed Built Up Area (Sq.mt.)	Proposed FAR Area (Sq.mt.)	Total Proposed Built Up Area (Sq.mt.)	Total FAR Area (Sq.mt.)
Ground Floor	133.64	117.26	133.64	117.26
First Floor	133.64	133.64	133.64	133.64
Terrace Floor	0.00	0.00	0.00	0.00
Total :	267.28	250.90	267.28	250.90

FAR & Tenement Details (Table 4c-1)

Building	No. of Same Bldg	Total Built Up Area (Sq.mt.)	Deductions (Area in Sq.mt.)	Proposed FAR Area (Sq.mt.)	Total FAR Area (Sq.mt.)	Total Consumed Additional FAR Area (Sq.mt.)	Tnmt (No.)
AA (AA)	1	267.28	16.38	250.90	250.90	250.90	01
Grand Total :	1	267.28	16.38	250.90	250.90	250.90	01

LTP NAME AND SIGNATURE	STRUCTURAL ENG'S NAME AND SIGNATURE	BUILDER NAME AND SIGNATURE	DIGITAL SIGNATURE
Lalan Prasad Singh MADA/ENG0001/2020			