

Project Title :SRI. KRISHNA KUMAR PANDEY

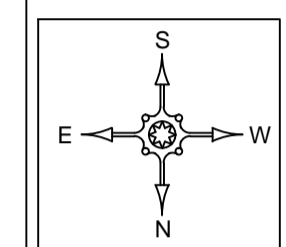
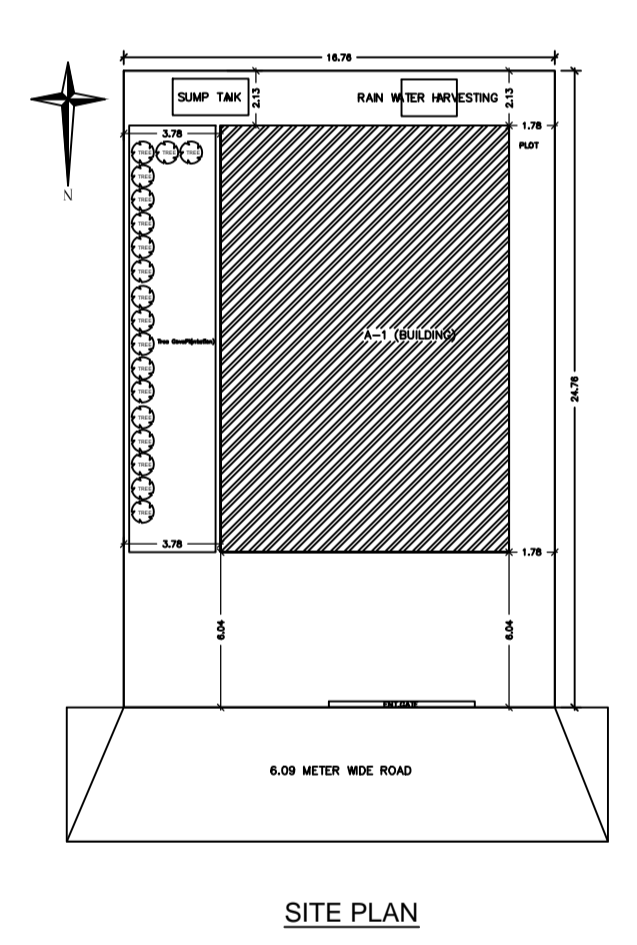
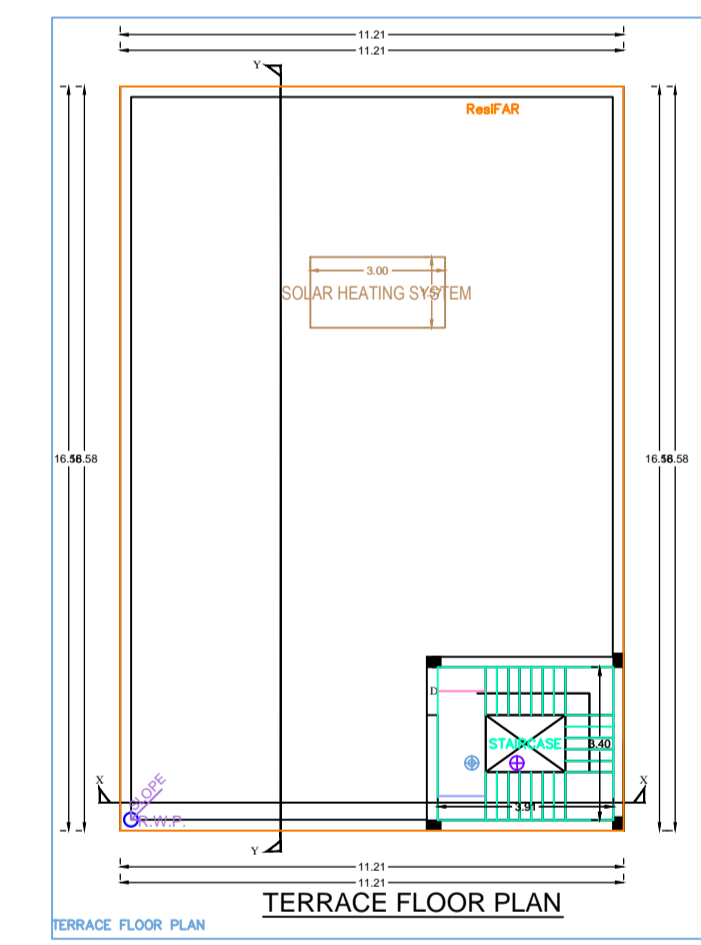
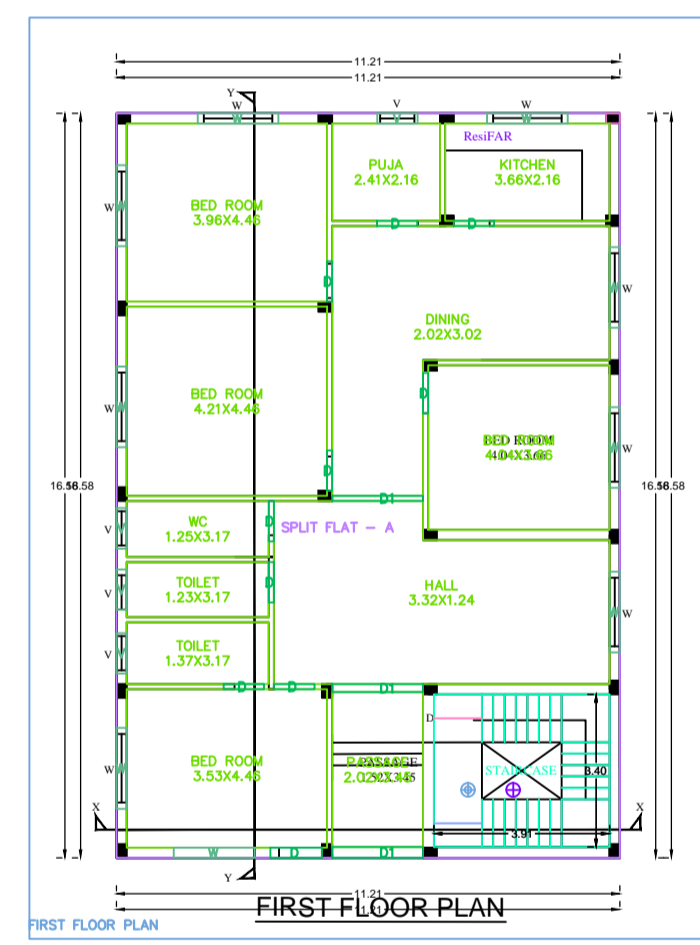
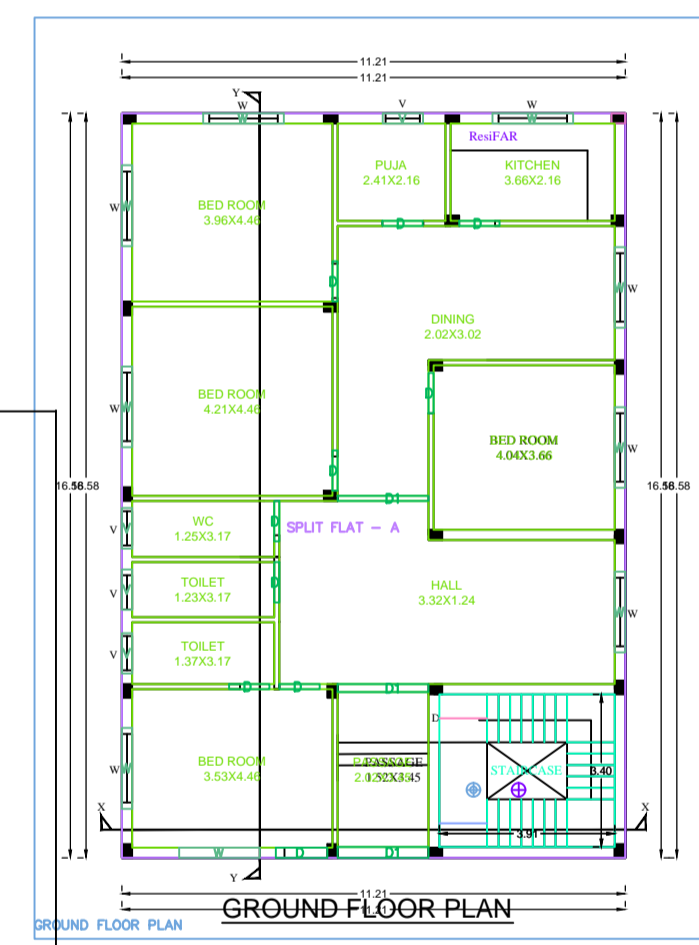
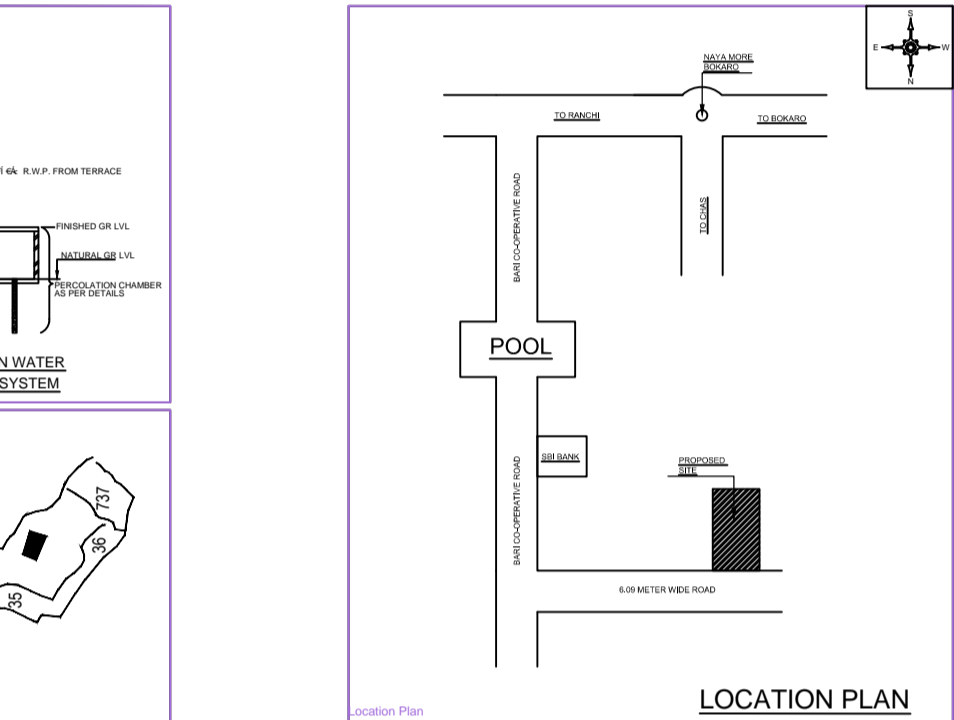
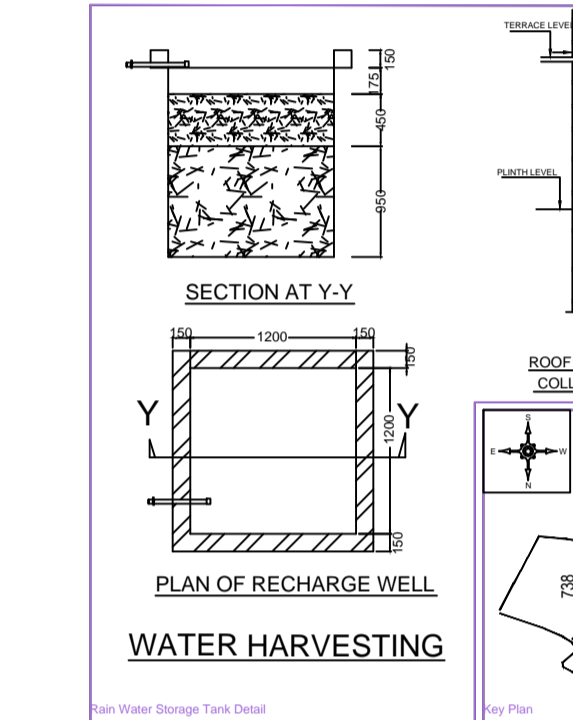
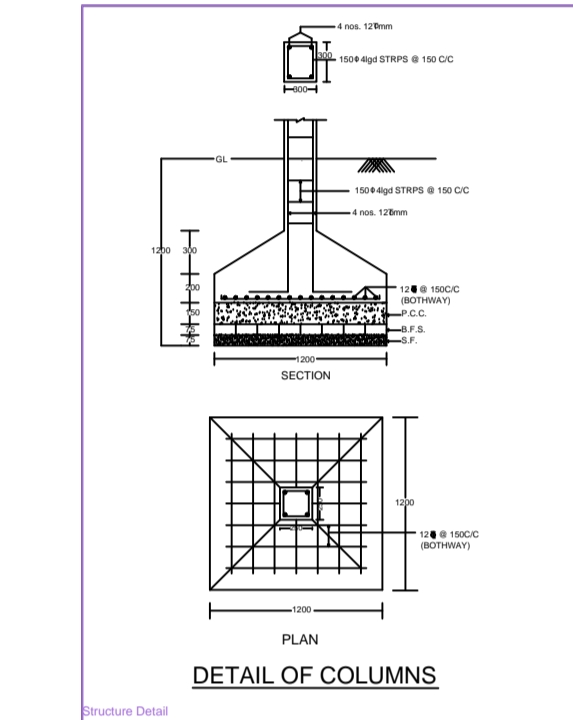
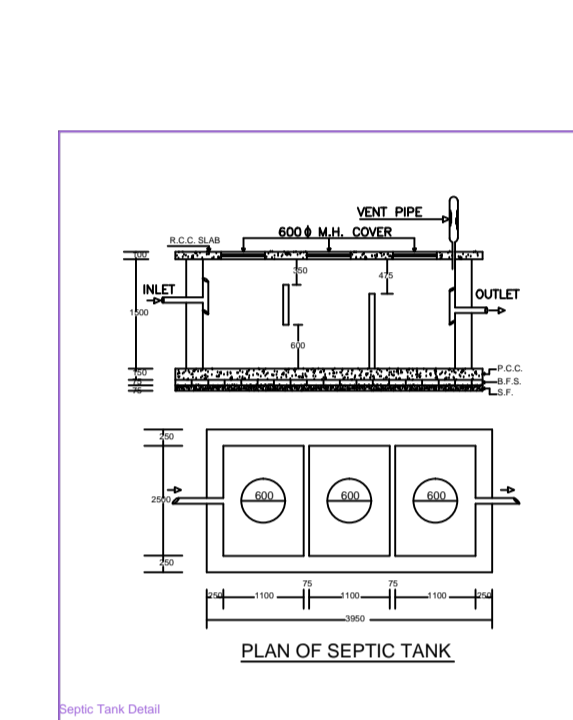
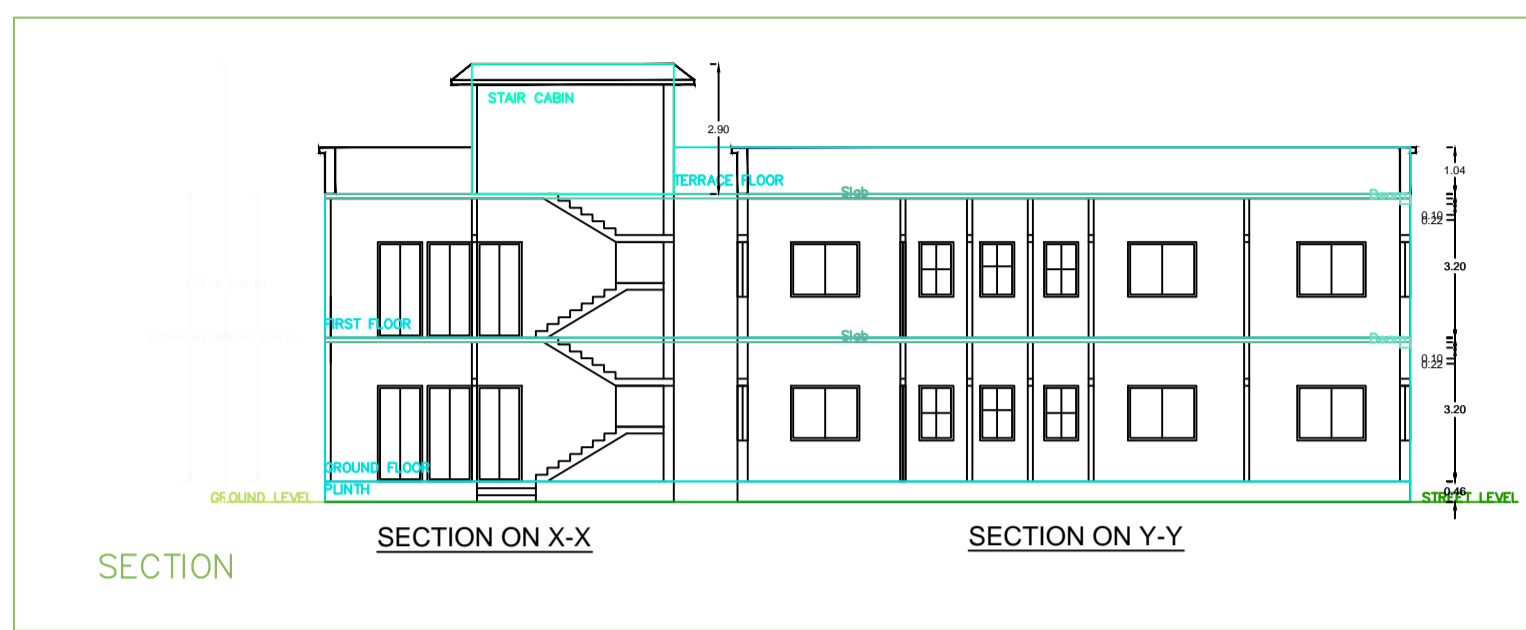
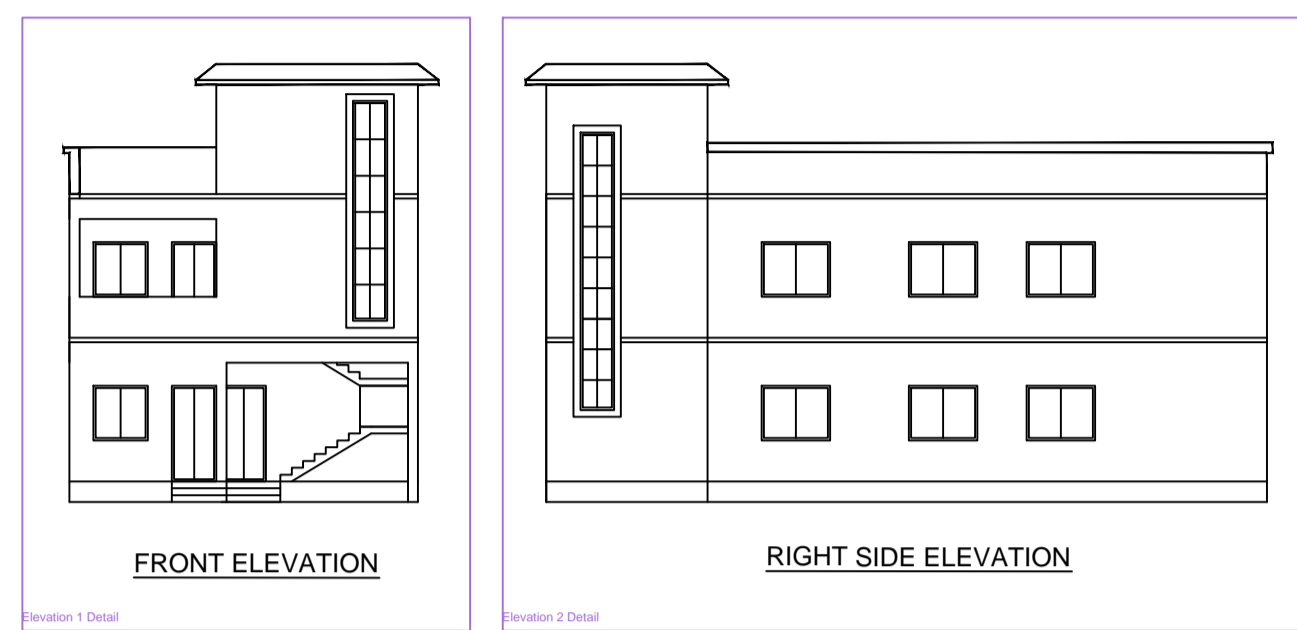

BRIEF SPECIFICATION

- FOUNDATION.....CEMENT CONCRETE (1:1.5:3)
- BRICK WORK IN FOUNDATION & SUPERSTRUCTURE
- FIRST CLASS BRICK WORK IN CEMENT MORTAR (1:6)
- D.P.C.....25 D.P.C. IN CEMENT CONCRETE (1:2:4)
- FLOOR.....25 I.P.S. OVER 75 P.C.C.
- ROOF.....100 THK. R.C.C. ROOF (1:1.5:3)
- LINTEL.....150 THK. R.C.C. LINTEL (1:1.5:3)
- STAIRS.....RISE- 150, TREAD- 250

DETAILS OF AREA

TOTAL AREA (AS PER DEED)	418.75 SQM.
TOTAL AREA (AS PER SITE)	415.01 SQM.
GROUND FLOOR AREA	185.86 SQM.
FIRST FLOOR AREA	185.86 SQM.
TOTAL COVERED AREA	371.72 SQM.
% PLINTH AREA	44.78 %
FAR	0.89

SCHEDULE

D = 1.500X2.100	W = 1.800X1.200
D1 = 1.050X2.100	V = 0.600X0.600
D2 = 0.900X2.100	

TITLE OF DRAWING

PLAN OF PROPOSED RESIDENTIAL BUILDING OF SRI. KRISHNA KUMAR PANDEY, S/o. SRI. SHIV GOPAL PANDEY, R.O. PLOT NO 262 BARI CO-OPERATIVE, P.O & P.S - SECTORE - 12, BOKARO STEEL CITY DIST - BOKARO (JHARKHAND) . MOUZA - TETULIA No.- 38, New Khata No 157. Old Khata No 37. New Plot No 738. Old Plot No 280 DISTT. OF DHANBAD (JHARKHAND).

SIGNATURE OF OWNER

SIGNATURE OF ENGINEER

SCALE ALL DIMENSION ARE IN METRE

Building :A (BUILDING)

Floor Name	Total Built Up Area (Sq.mt.)	Proposed FAR Area (Sq.mt.)	Total FAR Area (Sq.mt.)	Trent (No.)
Ground Floor	185.86	185.86	185.86	01
First Floor	185.86	185.86	185.86	01
Terrace Floor	0.00	0.00	0.00	00
Total	371.72	371.72	371.72	01
Total Number of Same Buildings	1			
Total	371.72	371.72	371.72	01

SCHEDULE OF JOINERY:

BUILDING NAME	NAME	LENGTH	HEIGHT	NOS
A (BUILDING)	D	1.90	2.10	18
A (BUILDING)	D	1.14	2.10	02
A (BUILDING)	W	2.05	2.10	08
Total				28

SCHEDULE OF JOINERY:

BUILDING NAME	NAME	LENGTH	HEIGHT	NOS
A (BUILDING)	V	0.80	1.80	08
A (BUILDING)	W	1.80	1.20	18
Total				26

Unit/BUA Table for Building :A (BUILDING)

FLOOR	Name	Unit/BUA Type	Unit/BUA Area	Carpet Area	No. of Rooms	No. of Treatment
GROUND FLOOR	SPLIT FLAT	FLAT	371.73	371.59	12	1
FIRST FLOOR	A		371.73	371.59	24	1
Total						

AREA STATEMENT (DHANBAD MUNICIPAL CORPORATION)		VERSION NO. 1.0.38			
PROJECT DETAIL		VERSION DATE: 16/10/2020			
Plot No.:	Residential				
Project Name:	Residential Building / Non Apartment				
Block No.:					
Application Type:	General Proposal				
Project Name:	Residential Building				
Plot No.:					
Location:	Thana No.:				
Sub Location:	Plot No.:				
Ward No.:	North:				
Block No.:	South:				
Block No.:	East:				
Block No.:	West:				
AREA DETAILS:		SQ.MT.			
AREA OF PLOT (Minimum)	(A)	415.01			
Net Plot Area (Gross Plot Area - Deduction for Gross Plot Area)	(A Deductions)	415.01			
Deductions for Balance Plot Area (from Gross Plot Area)					
GOP Area		50.87			
Balance Plot Area (Net Plot Area - Deductions)	(A Deductions)	364.14			
Plot Area for Coverage (Net Plot Area)	(A Deductions)	415.01			
Plot Area for FAR (Net Plot Area - Deductions)	(A Deductions)	415.01			
COVERAGE CHECK					
Proposed Coverage Area (44.78 %)		185.86			
Total Coverage Area (44.78 %)		185.86			
FAR CHECK					
Proposed FAR		371.72			
Total FAR		371.72			
BUILD UP AREA CHECK					
Total Proposed Building Area		371.72			
ARCHT. ENGR. SUPERVISOR (Regd.)		OWNER			
DEVELOPMENT AUTHORITY		LOCAL BODY			
COLOR INDEX					
FLAT BOUNDARY					
ARBITRARY ROAD					
PROPOSED WORK (COVERAGE AREA)					
EXISTING (To be retained)					
EXISTING (To be demolished)					
Color Index:					
MARGIN DETAIL:					
Building /Wing	Floor Name	Front Margin	Rear Margin	Side Margin	Setback Margin
A (BUILDING)	6.09 METER WIDE ROAD	6.04	2.10	3.78	1.78
FAR & Tenament Details (Table A-c-1)					
Building	No. of Same Wing	Total Built Up Area (Sq.mt.)	Proposed FAR Area (Sq.mt.)	Total FAR Area (Sq.mt.)	Trent (No.)
A (BUILDING)	1	371.72	371.72	371.72	01
Grand Total	1	371.72	371.72	371.72	01