

**SITE PLAN**  
SCALE - 1" = 16'-0"

SCHEDULE OF DOOR:

BUILDING NAME	NAME	LENGTH	HEIGHT	NOS
A (RAHUL SINHA)	D2	0.61	2.10	01
A (RAHUL SINHA)	D2	0.76	2.10	03
A (RAHUL SINHA)	D	0.91	2.10	02
A (RAHUL SINHA)	D1	0.91	2.10	01
A (RAHUL SINHA)	D	0.97	2.10	01
A (RAHUL SINHA)	D	1.07	2.10	03
A (RAHUL SINHA)	D	1.08	2.10	01

SCHEDULE OF WINDOW/VENTILATION:

BUILDING NAME	NAME	LENGTH	HEIGHT	NOS
A (RAHUL SINHA)	V	0.61	1.20	02
A (RAHUL SINHA)	V	0.76	1.20	01
A (RAHUL SINHA)	W1	0.91	1.20	01
A (RAHUL SINHA)	W1	1.22	1.20	03
A (RAHUL SINHA)	W	1.52	1.20	09

Building :A (RAHUL SINHA)

Floor Name	Total Built Up Area (Sq.mt.)	Deductions (Area in Sq.mt.) Arch.Proj.	Proposed FAR Area (Sq.mt.) Resi.	Total FAR Area (Sq.mt.)	Total Consumed Additional FAR Area (Sq.mt.)	Tnmt (No.)
Ground Floor	90.59	16.14	74.45	74.45	74.45	01
First Floor	89.66	0.00	89.66	89.66	89.66	00
Terrace Floor	0.00	0.00	0.00	0.00	0.00	00
Total:	180.25	16.14	164.11	164.11	164.11	01
Total Number of Same Buildings :	1	-	-	-	-	-
Total :	180.25	16.14	164.11	164.11	164.11	01

UnitBUA Table for Building :A (RAHUL SINHA)

FLOOR	Name	UnitBUA Type	UnitBUA Area	Carpel Area	No. of Rooms	No. of Tenement
GROUND FLOOR PLAN	SPLIT 1	FLAT	147.04	146.97	5	1
FIRST FLOOR PLAN	SPLIT 1	FLAT	0.00	0.00	7	0
Total:	-	-	147.04	146.97	12	1

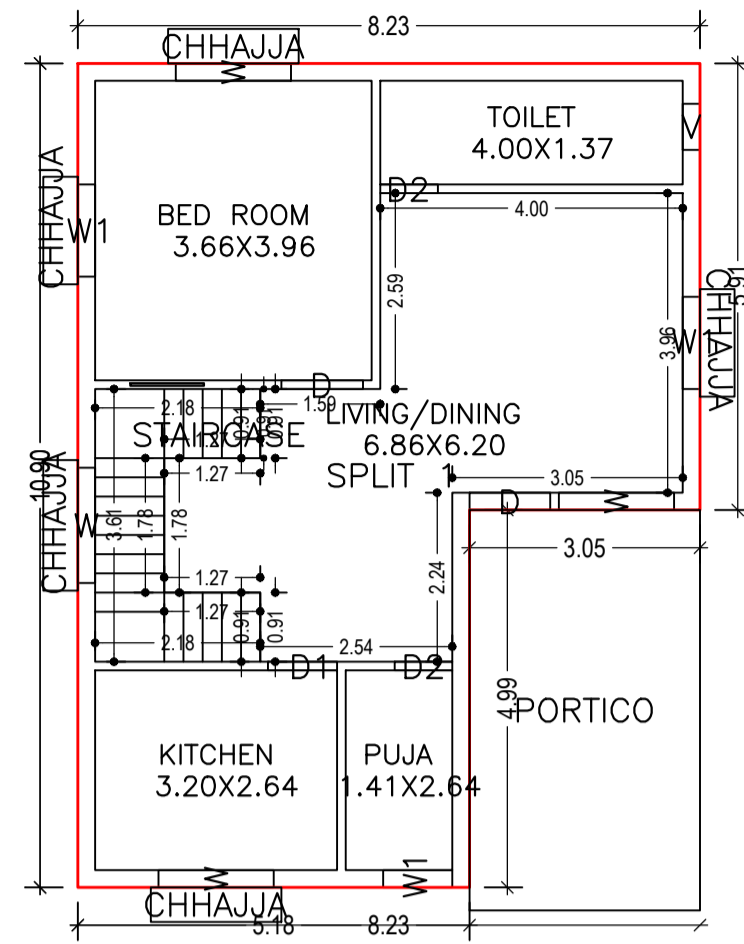

**GROUND FLOOR PLAN (Proposed)**  
SCALE 1:100

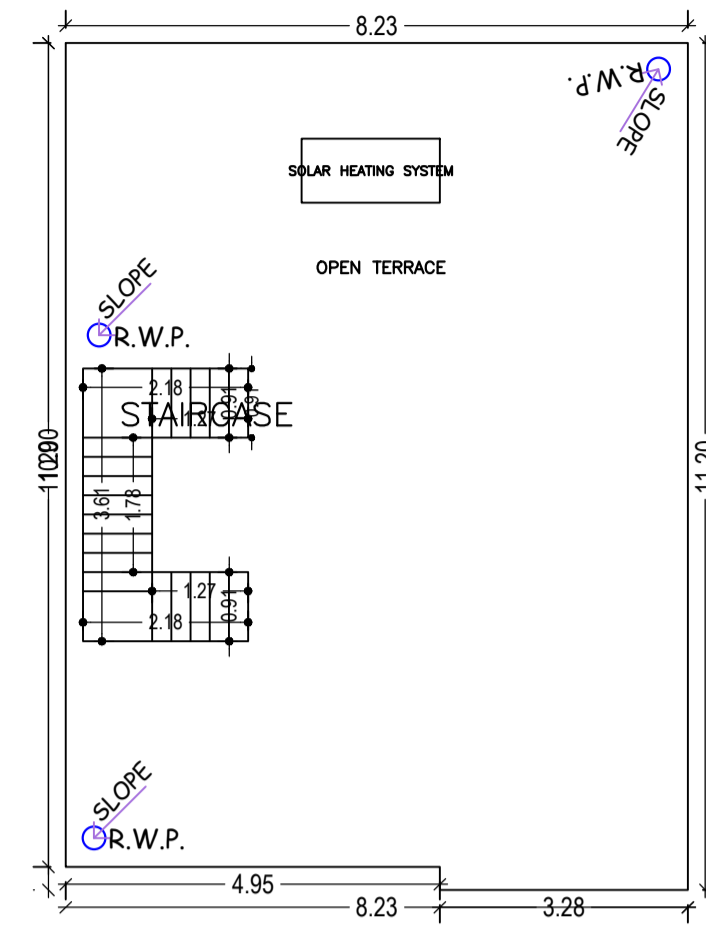

**TERRACE FLOOR PLAN (SCALE 1:100)**

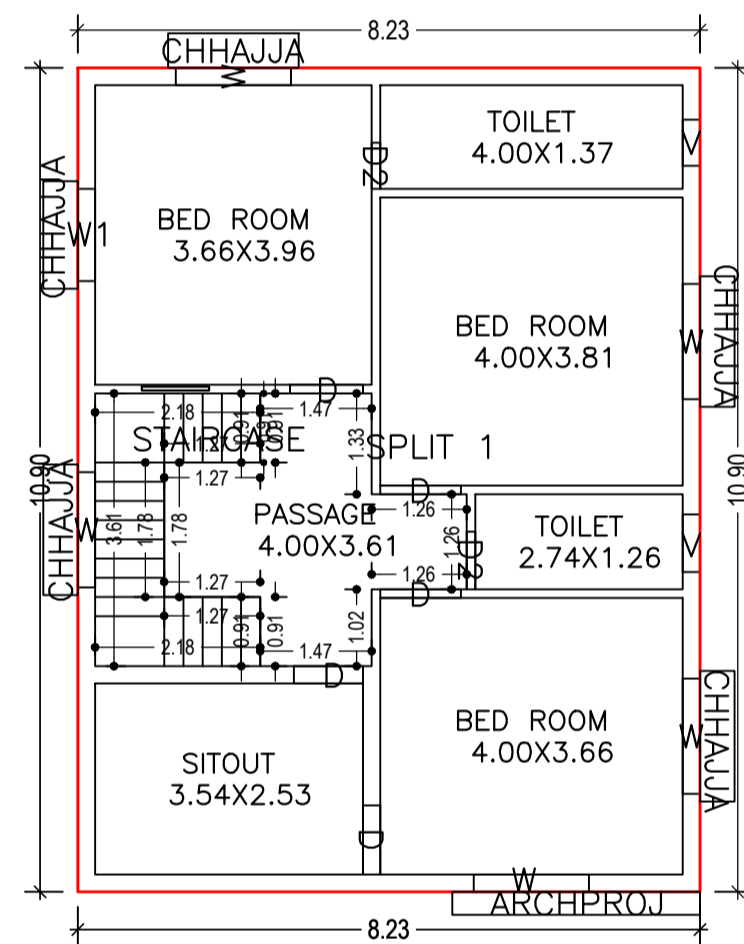

**FIRST FLOOR PLAN (Proposed)**  
SCALE 1:100

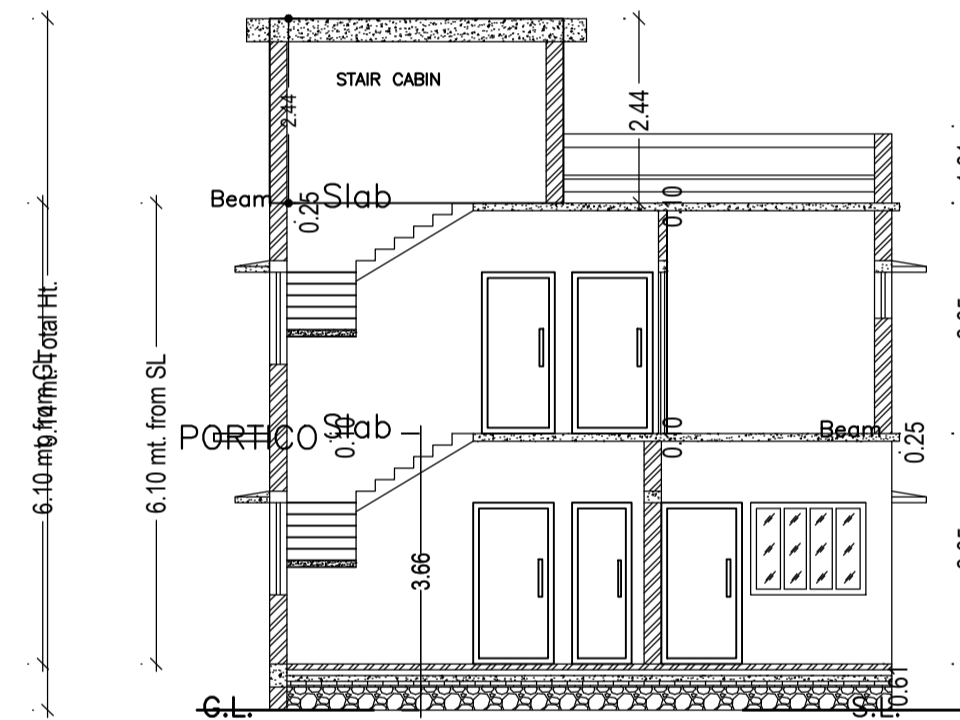

**SECTION - XX'**  
SCALE - 1" = 8'-0"

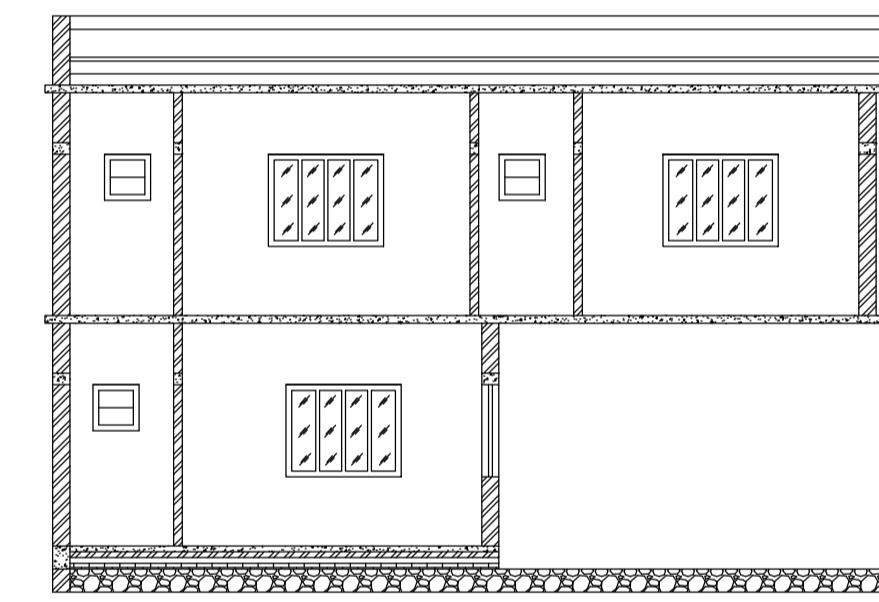

**SECTION - YY'**  
SCALE - 1" = 8'-0"

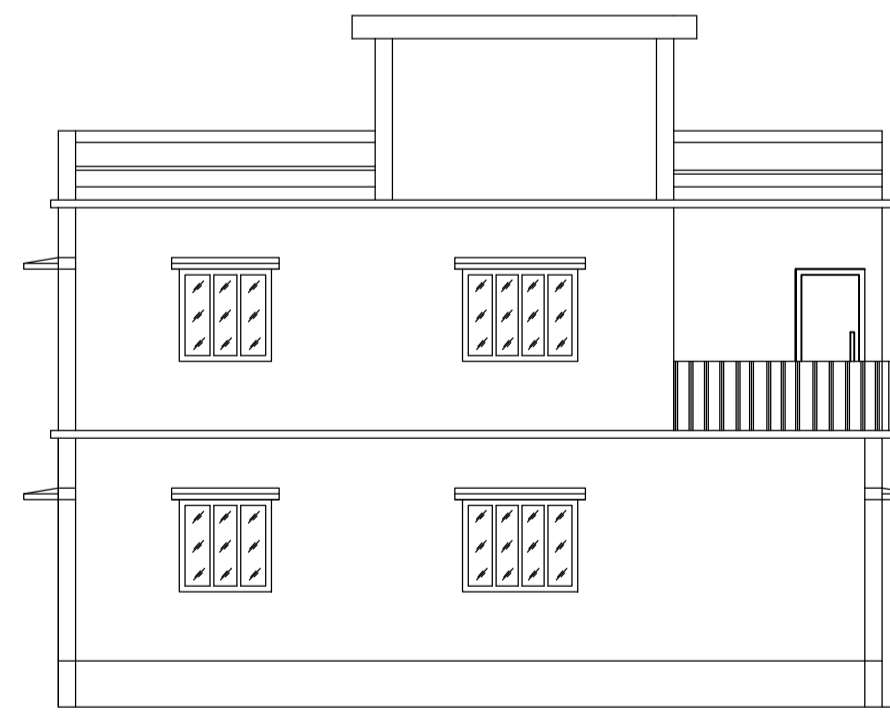

**LEFT SIDE ELEVATION**  
SCALE - 1" = 8'-0"

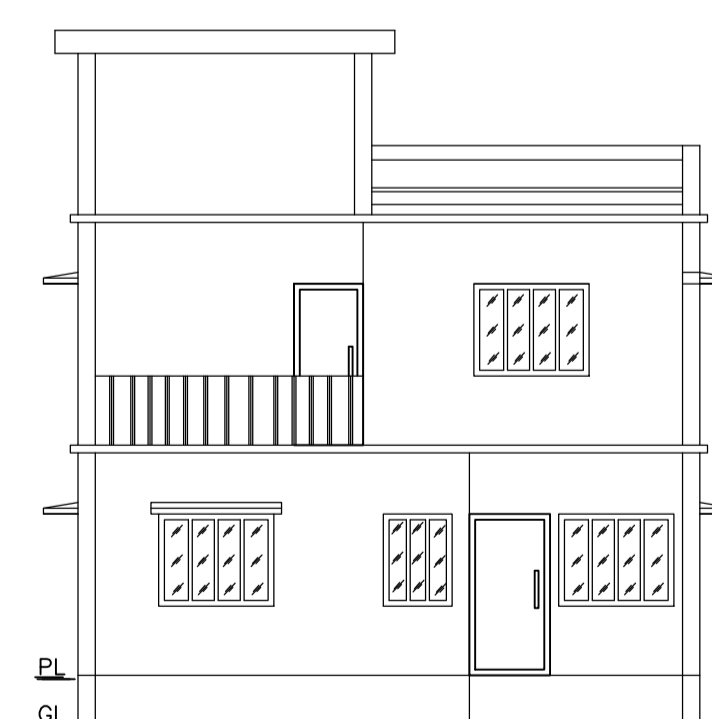

**FRONT ELEVATION**  
SCALE - 1" = 8'-0"

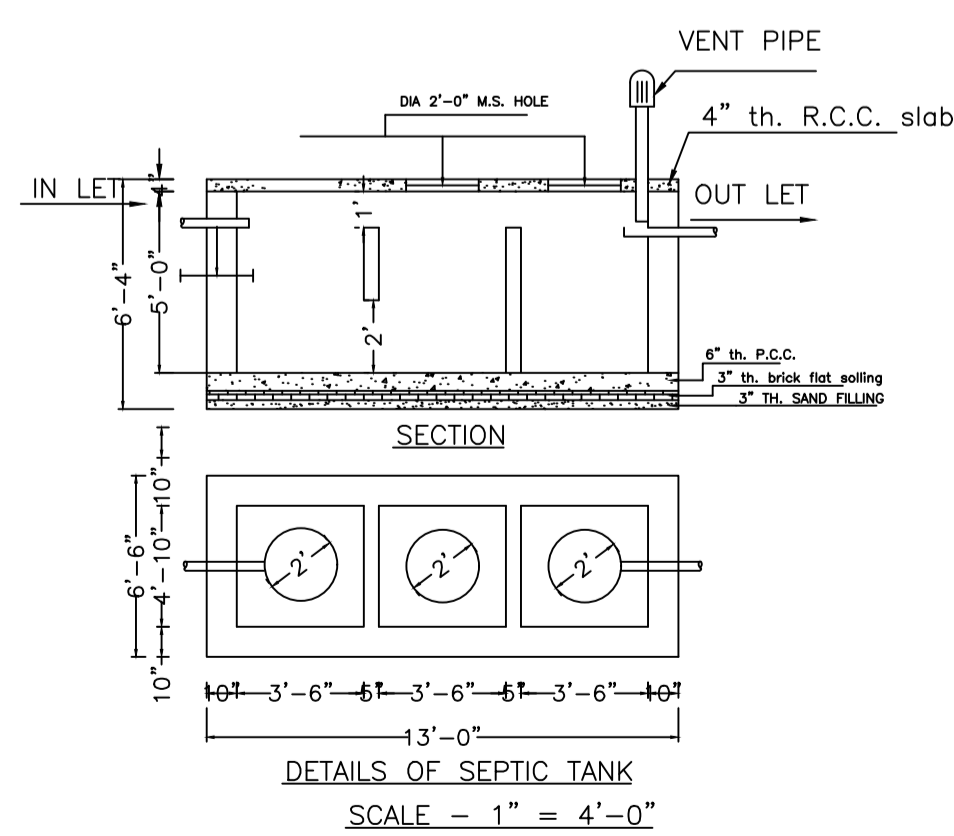

**DETAILS OF SEPTIC TANK**  
SCALE - 1" = 4'-0"

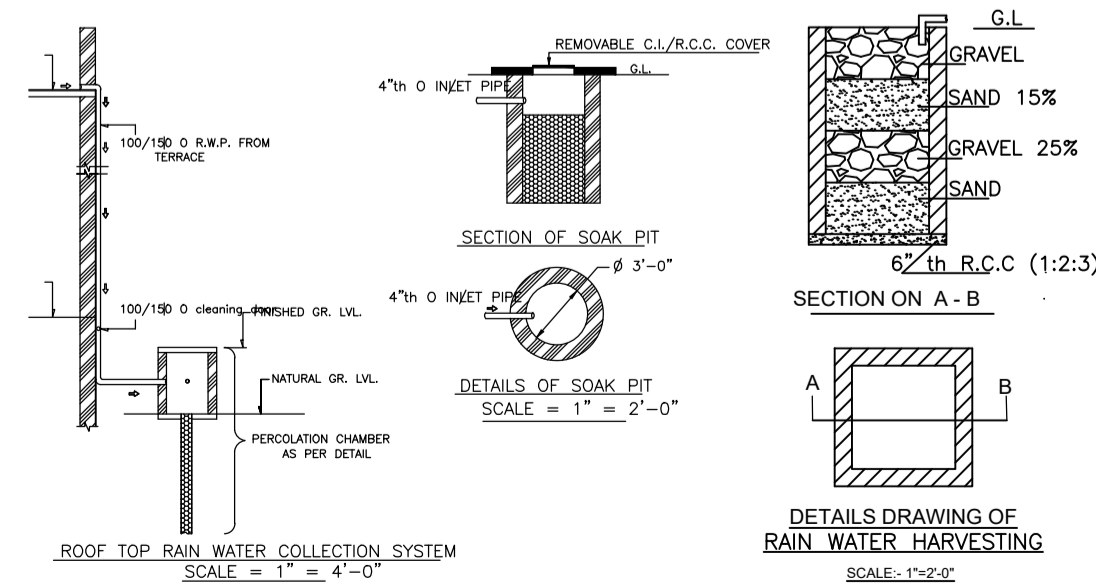

**DETAILS DRAWING OF RAIN WATER HARVESTING**  
SCALE - 1" = 4'-0"

FAR & Tenement Details (Table 4c-1)

Building	No. of Same Bldg	Total Built Up Area (Sq.mt.)	Deductions (Area in Sq.mt.) Arch.Proj.	Proposed FAR Area (Sq.mt.) Resi.	Total FAR Area (Sq.mt.)	Total Consumed Additional FAR Area (Sq.mt.)	Tnmt (No.)
A (RAHUL SINHA)	1	180.25	16.14	164.11	164.11	164.11	01
Grand Total :	1	180.25	16.14	164.11	164.11	164.11	01

Proposal Basic Information

Proposal File No.	MADA/BP/0346/2023
Owner Name	SRI. RAHUL SINHA
Khata No	OLD KHATA NO-16, NEW KHATA NO-14
Plot No	OLD PLOT NO-78 & 78, NEW PLOT NO-189 & 190
Village Name	Tilakraydih
Use	Residential
SubUse	Bungalow/ Dwelling / Non Apartment

AREA STATEMENT MINERAL AREA DEVELOPMENT AUTHORITY		VERSION NO. : 1.0.68
PROJECT DETAIL:		VERSION DATE: 16/10/2020
Region: JHARKHAND URBAN LOCAL BODIES	Plot Use: Residential	
Authority: MINERAL AREA DEVELOPMENT AUTHORITY	PlotSubUse: Bungalow/ Dwelling / Non Apartment	
Inward No: MADA/BP/0346/2023	Plot/SubPlot No: OLD PLOT NO-78 & 78, NEW PLOT NO-189 & 190	
Application Type: General Proposal	North: Plot No. - SAME PLOT	
Project Type: Building Permission	South: Plot No. - SAME PLOT	
Nature of Development: New	East: Road Width - 6.10	
Location of Development Area: Old Area	West: Plot No. - SAME PLOT	
AREA DETAILS:		SQ.MT.
AREA OF PLOT (Minimum)	(A)	153.03
NET AREA OF PLOT(Gross Plot Area - Deduction from Gross Plot area)	(A-Deductions)	153.03
Deduction for Balance Plot Area(from Gross Plot Area)		
Common Plot		17.32
Total		17.32
BALANCE AREA OF PLOT(Net Plot Area - Recreational/Amenity space)	(A-Deductions)	135.71
PLOT AREA FOR COVERAGE(Net Plot Area + Road Widening Area)	(A-Deductions)	153.03
Plot Area for FAR (Net Plot Area + Road Widening Area)	(A-Deductions)	153.03
COVERAGE CHECK		
Permissible Coverage area ( 70.00 % )		107.12
Proposed Coverage Area ( 48.65 % )		74.45
Total Prop. Coverage Area ( 48.65 % )		74.45
Balance coverage area ( 21.35 % )		32.67
FAR CHECK		
Perm. FAR Area ( 2.500 )		382.58
Total Perm. FAR area		382.58
Residential FAR		164.11
Proposed FAR Area		164.11
Total Proposed FAR Area		164.11
Consumed FAR (Factor)		1.07
Balance FAR Area		218.47
BUILT UP AREA CHECK		
Total Proposed BuiltUp Area		180.25
ARCHITECT (Regd)		KINGSLEY SOURAV KISKU RAPAZ
ENGINEER (Regd)		
SUPERVISOR (Regd)		
OWNER (Regd)		SRI. RAHUL SINHA
DEVELOPMENT AUTHORITY		LOCAL BODY

COLOR INDEX	
PLOT BOUNDARY	Black
ABUTTING ROAD	Green
PROPOSED CONSTRUCTION	Red
COMMON PLOT	Yellow
ROAD WIDENING AREA	Blue
EXISTING (To be retained)	Light Blue
EXISTING (To be demolished)	Dark Blue

Buildingwise Floor FAR Details

Floor Name	Building Name A (RAHUL SINHA)		Total	
	Proposed Built Up Area (Sq.mt.)	Proposed FAR Area (Sq.mt.)	Total Proposed Built Up Area (Sq.mt.)	Total FAR Area (Sq.mt.)
Ground Floor	90.59	74.45	90.59	74.45
First Floor	89.66	89.66	89.66	89.66
Terrace Floor	0.00	0.00	0.00	0.00
Total :	180.25	164.11	180.25	164.11

Building USE/SUBUSE Details

Building Name	Building Use	Building SubUse	Building Structure
A (RAHUL SINHA)	Residential	Bungalow/ Dwelling / Non Apartment	Non-Highrise

LTP NAME AND SIGNATURE	STRUCTURAL ENG'S NAME AND SIGNATURE	BUILDER NAME AND SIGNATURE	DIGITAL SIGNATURE
KINGSLEY SOURAV KISKU RAPAZ MADA/ARC/0005/2022			