

Proposal Basic Information

Proposal File No.	MADA/BP/0353/2023
Owner Name	SMT. PRIYA DEVI
Khata No	OLD KHATA NO-43 & 3, NEW KHATA NO-74 & 32
Plot No	OLD PLOT NO-1151 & 1152, NEW PLOT NO-1351 & 1353
Village Name	Kurmidih
Use	Residential
SubUse	Bungalow/ Dwelling / Non Apartment

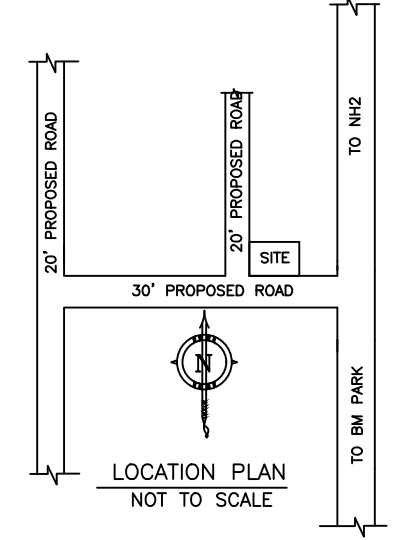
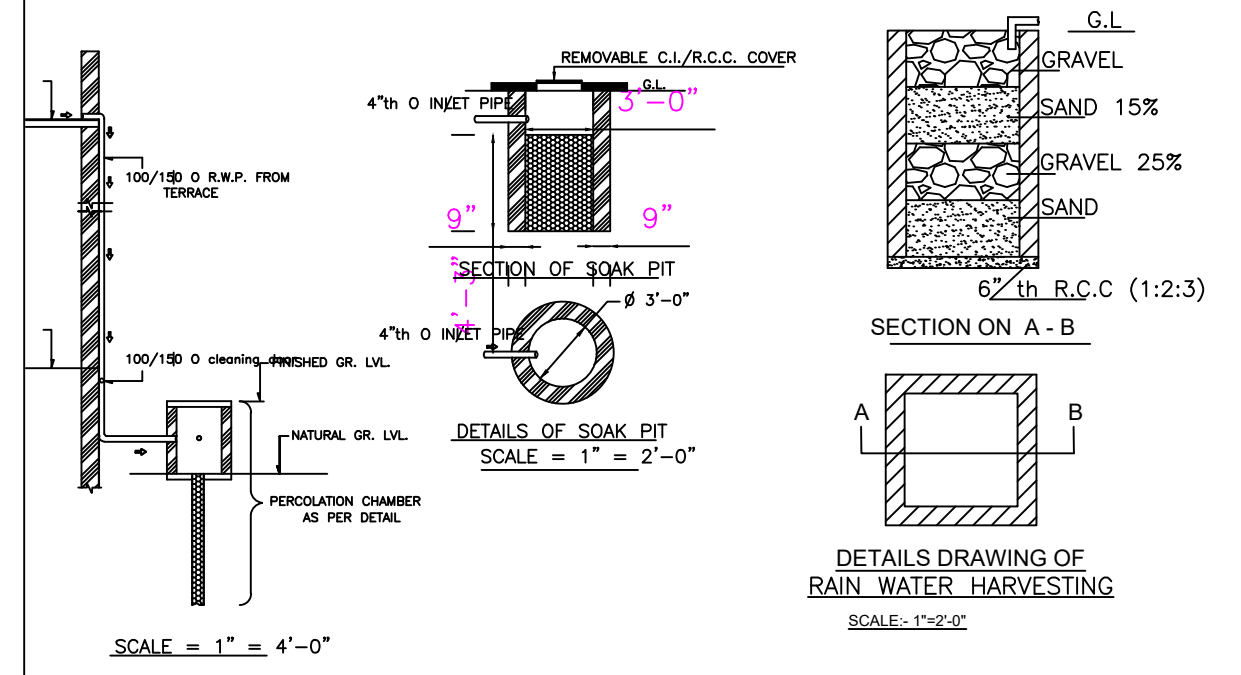
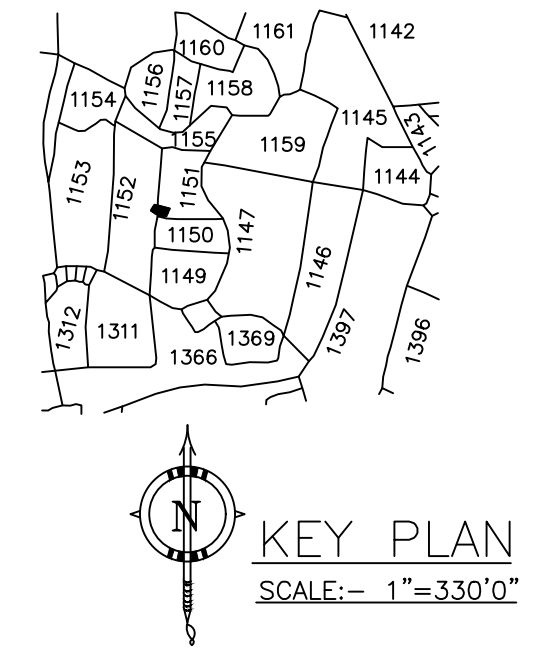
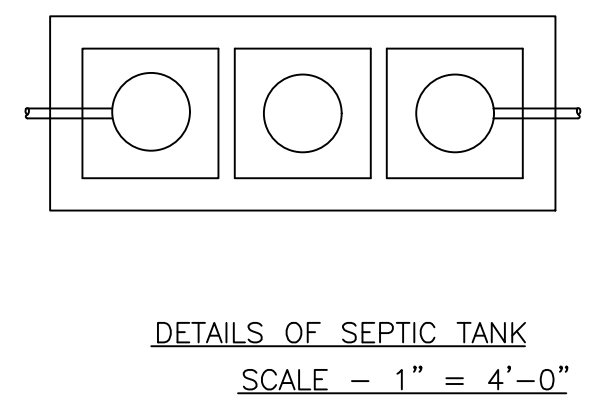
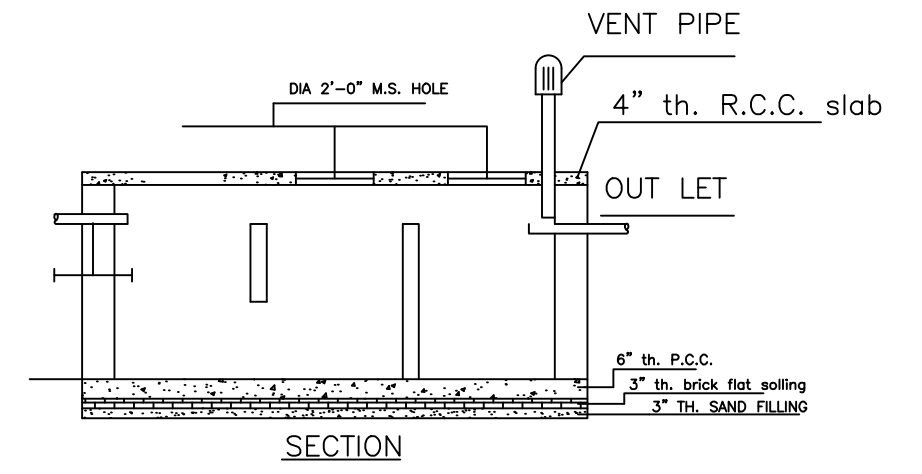
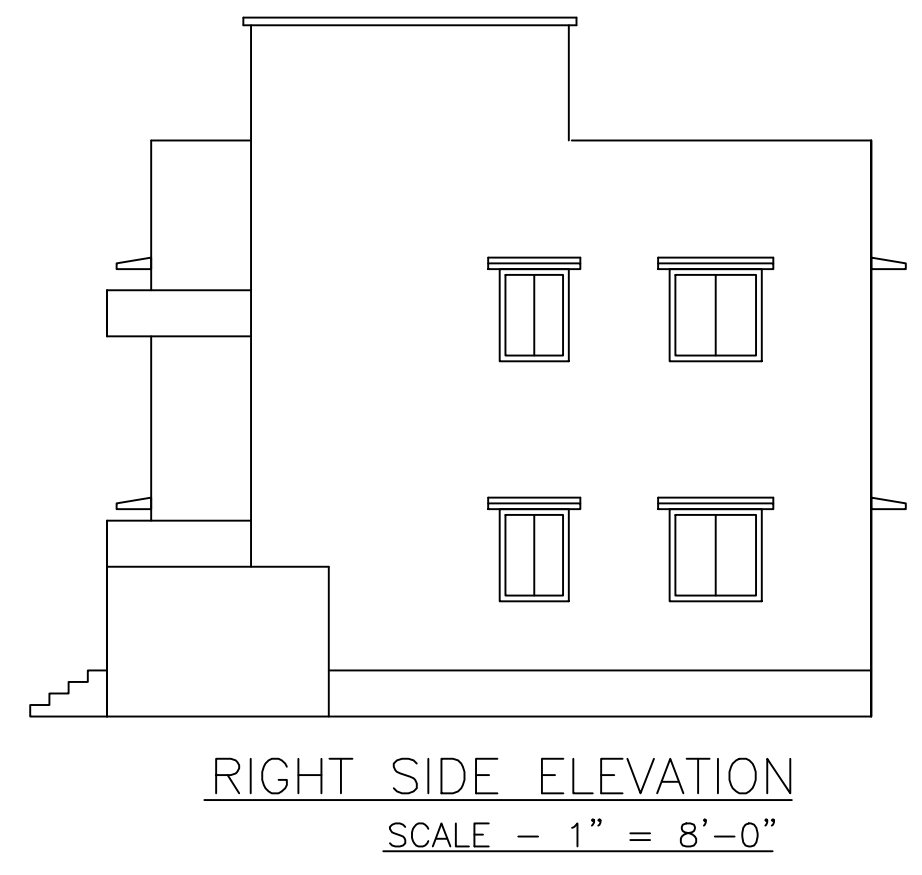
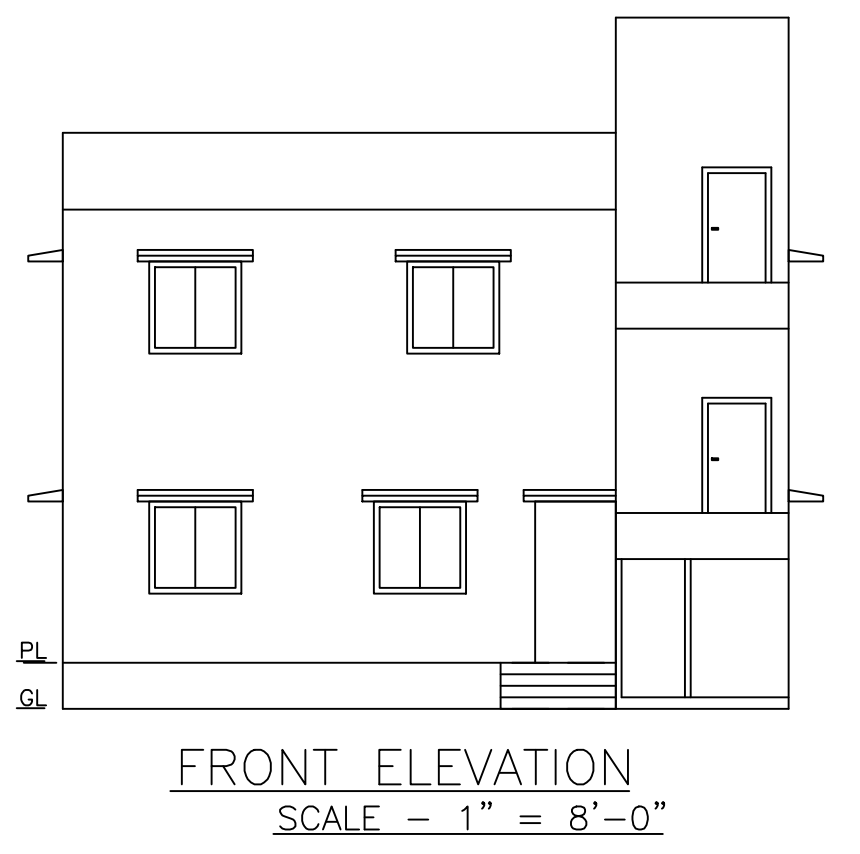
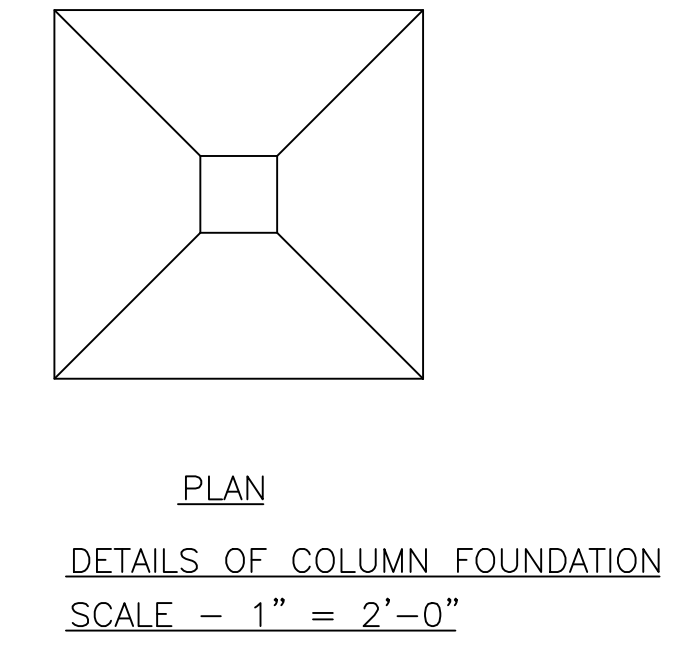
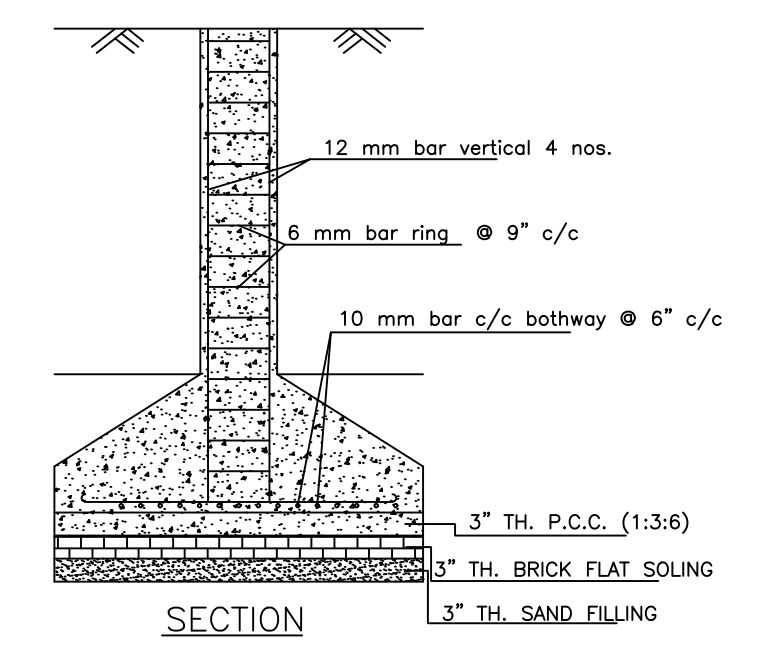
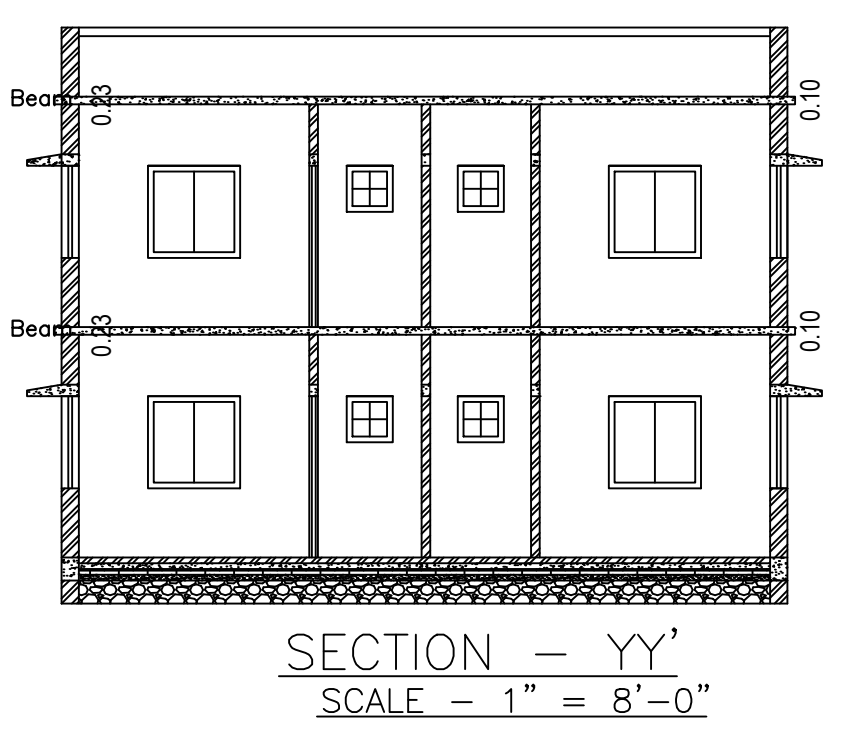
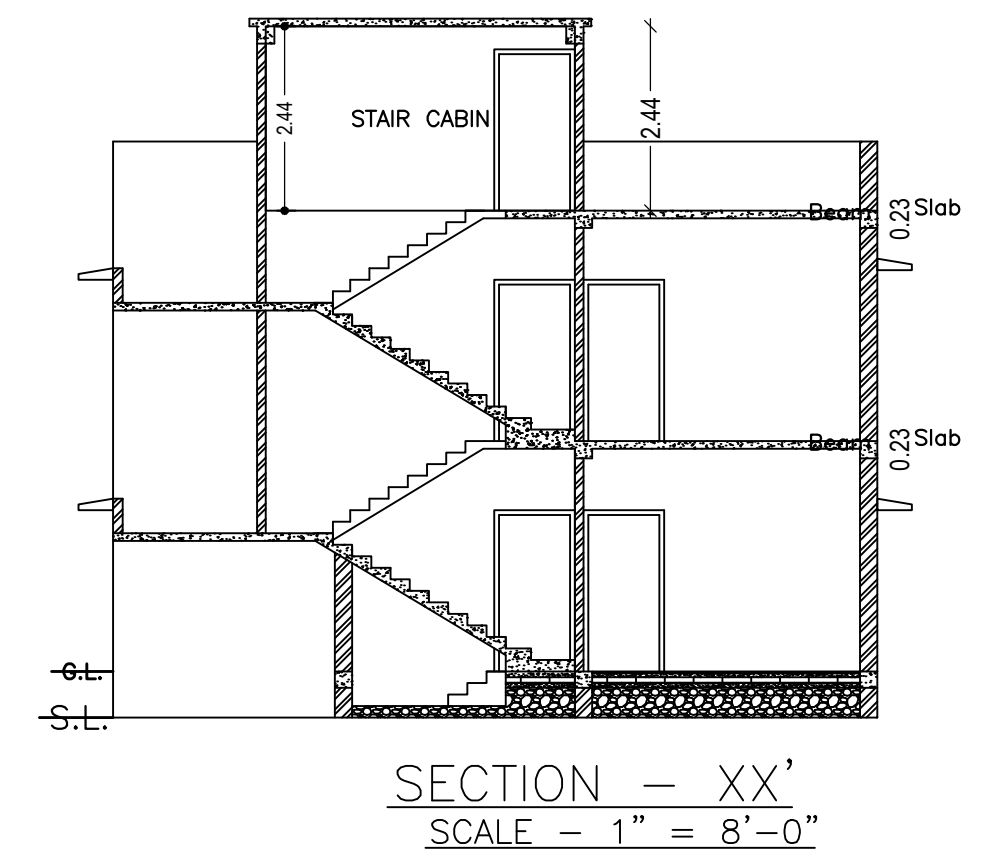
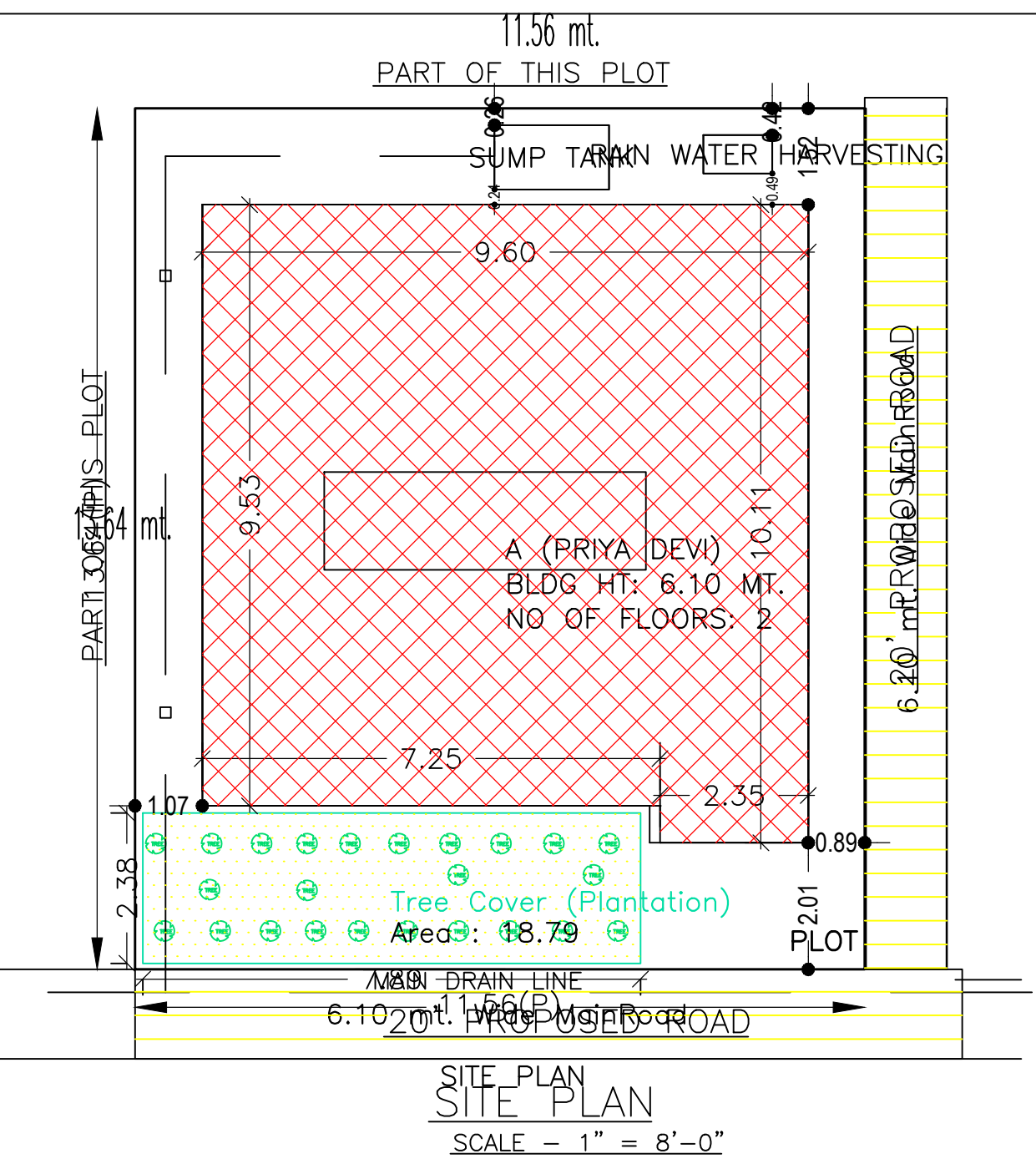

AREA STATEMENT MINERAL DEVELOPMENT AUTHORITY	REGIONAL DEVELOPMENT AUTHORITY	VERSION NO.: 1.0.66	VERSION DATE: 16/10/2020
PROJECT DETAIL:		Plot Use: Residential	
Region: JHARKHAND URBAN LOCAL BODIES	Plot SubUse: Bungalow/ Dwelling / Non Apartment		
District: DHANBAD	PlotNearbyReligiousStructure: NA		
Authority: MINERAL AREA DEVELOPMENT AUTHORITY	PlotNearbyReligiousStructure: NA		
Inward No: MADA/BP/0353/2023	PlotSubPlot No: OLD PLOT NO-1151 & 1152, NEW PLOT NO-1351 & 1353		
Application Type: General Proposal	North: Plot No. - SAME PLOT		
Project Type: Building Permission	South: Road Width - 6.10		
Nature of Development: New	East: Plot No. - SAME PLOT		
Location of Development Area: Old Area	West: Road Width - 6.10		
AREA DETAILS:			SQ.MT.
AREA OF PLOT (Minimum)	(A)		157.71
NET AREA OF PLOT(Gross Plot Area - Deduction from Gross Plot area)	(A-Deductions)		157.71
Deduction for Balance Plot Area(from Gross Plot Area)			
Common Plot			18.79
Total			18.79
BALANCE AREA OF PLOT(Net Plot Area - Recreational/Amenity space)	(A-Deductions)		138.92
PLOT AREA FOR COVERAGE(Net Plot Area)	(A-Deductions)		157.71
Plot Area for FAR (Net Plot Area + RoadWidening Area)	(A-Deductions)		157.71
COVERAGE CHECK			
Permissible Coverage area (70.00 %)			110.40
Proposed Coverage Area (58.86 %)			92.82
Total Prop. Coverage Area (58.86 %)			92.82
Balance coverage area (11.15 %)			17.58
FAR CHECK			
Perm. FAR Area (2.500)			394.28
Total Perm. FAR area			394.28
Residential FAR			185.65
Proposed FAR Area			185.65
Total Proposed FAR Area			185.65
Consumed FAR (Factor)			1.18
Balance FAR Area			208.63
BUILT UP AREA CHECK			
Total Proposed BuiltUp Area			185.64
ARCHITECT (Regd)			RAM PRATAP SINGH
ENGINEER (Regd)			
SUPERVISOR (Regd)			
OWNER (Regd)			SMT. PRIYA DEVI
DEVELOPMENT AUTHORITY			LOCAL BODY

COLOR INDEX

PLOT BOUNDARY	Black
ABUTTING ROAD	Green
PROPOSED CONSTRUCTION	Red
COMMON PLOT	Yellow
ROAD WIDENING AREA	Blue
EXISTING (To be retained)	White
EXISTING (To be demolished)	Grey

Buildingwise Floor FAR Details

Floor Name	Building Name		Total	
	Proposed Built Up Area (Sq.mt.)	Proposed FAR Area (Sq.mt.)	Total Proposed Built Up Area (Sq.mt.)	Total FAR Area (Sq.mt.)
Ground Floor	92.82	92.82	92.82	92.82
First Floor	92.82	92.82	92.82	92.82
Terrace Floor	0.00	0.00	0.00	0.00
Total :	185.64	185.64	185.64	185.64

Building USE/SUBUSE Details

Building Name	Building Use	Building SubUse	Building Structure
A (PRIYA DEVI)	Residential	Bungalow/ Dwelling / Non Apartment	Non-Highrise

FAR & Tenement Details (Table 4c-1)

Building	No. of Same Bldg	Total Built Up Area (Sq.mt.)	Proposed FAR Area (Sq.mt.)	Total FAR Area (Sq.mt.)	Total Consumed Additional FAR Area (Sq.mt.)	Trmt (No.)
A (PRIYA DEVI)	1	185.64	185.64	185.64	185.64	01
Grand Total :	1	185.64	185.64	185.64	185.64	01

Building :A (PRIYA DEVI)

Floor Name	Total Built Up Area (Sq.mt.)	Proposed FAR Area (Sq.mt.)	Total FAR Area (Sq.mt.)	Total Consumed Additional FAR Area (Sq.mt.)	Trmt (No.)
Ground Floor	92.82	92.82	92.82	92.82	01
First Floor	92.82	92.82	92.82	92.82	00
Terrace Floor	0.00	0.00	0.00	0.00	00
Total :	185.64	185.64	185.64	185.64	01
Total Number of Same Buildings :	1				
Total :	185.64	185.64	185.64	185.64	01

SCHEDULE OF DOOR:

BUILDING NAME	NAME	LENGTH	HEIGHT	NOS
A (PRIYA DEVI)	D	0.84	2.10	04
A (PRIYA DEVI)	D	0.91	2.10	04
A (PRIYA DEVI)	D	1.07	2.10	08
A (PRIYA DEVI)	D	1.08	2.10	01
A (PRIYA DEVI)	D	1.23	2.10	01

SCHEDULE OF WINDOW/VENTILATION:

BUILDING NAME	NAME	LENGTH	HEIGHT	NOS
A (PRIYA DEVI)	V	0.61	1.20	04
A (PRIYA DEVI)	W	0.91	1.20	04
A (PRIYA DEVI)	W	1.22	1.20	12
A (PRIYA DEVI)	W	2.22	1.20	02

UnitBUA Table for Building :A (PRIYA DEVI)

FLOOR	Name	UnitBUA Type	UnitBUA Area	Carpet Area	No. of Rooms	No. of Tenement
GROUND FLOOR PLAN	SPLIT A	FLAT	185.65	185.50	8	1
FIRST FLOOR PLAN	SPLIT A	FLAT	0.00	0.00	8	0
Total:	-	-	185.65	185.50	16	1

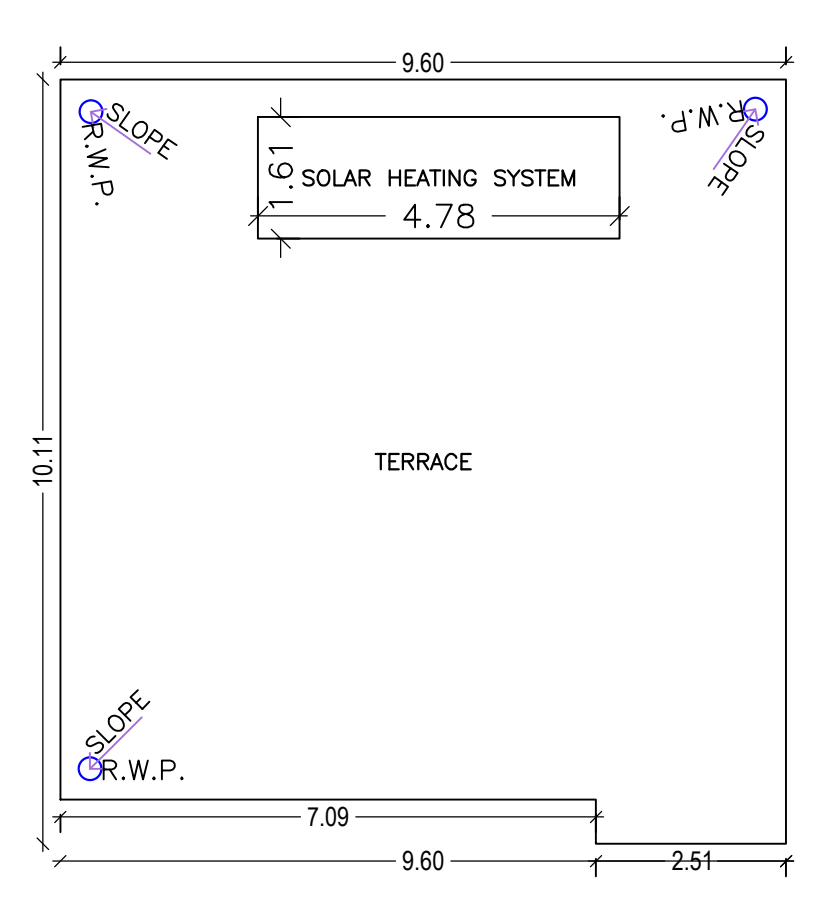
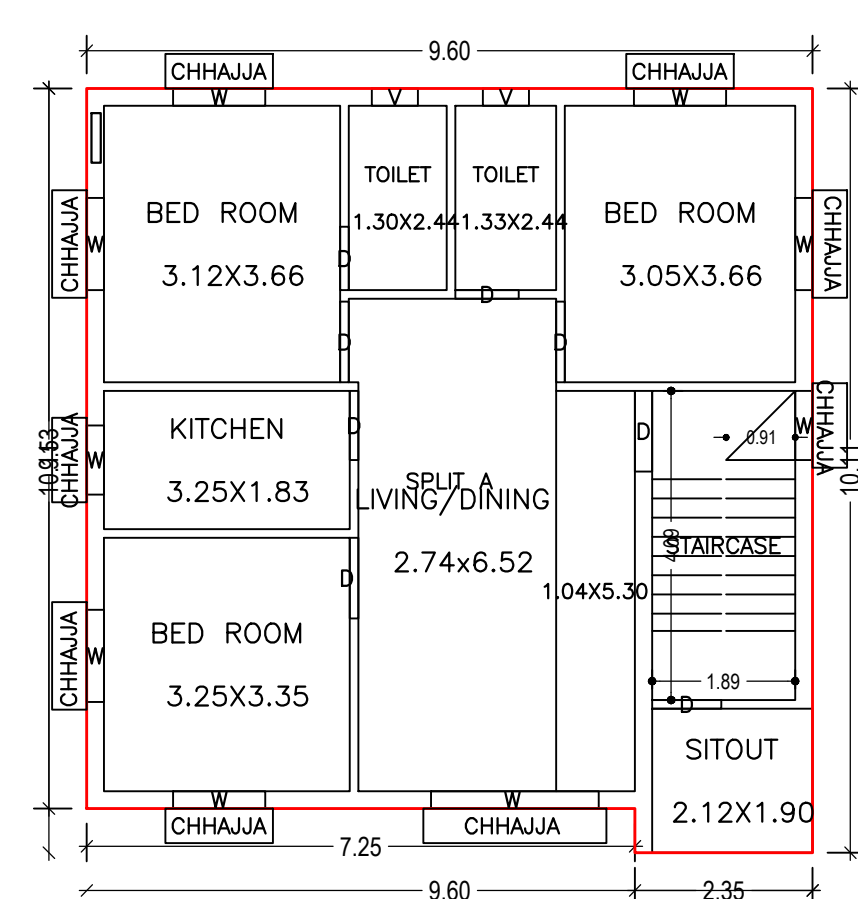
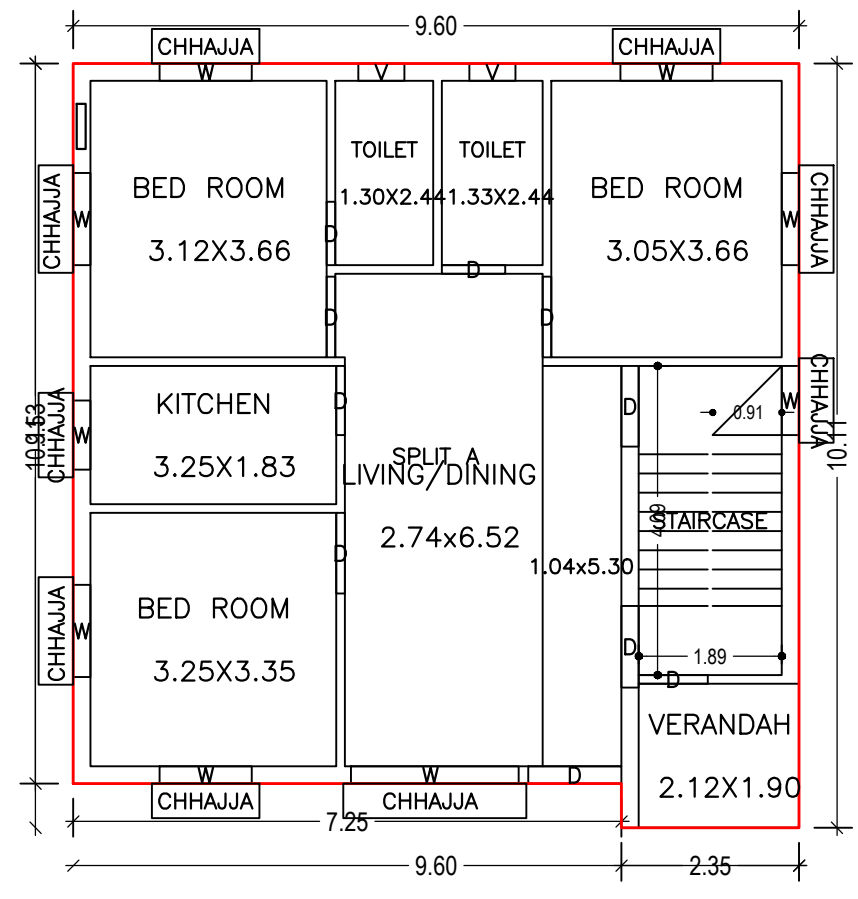

LTP NAME AND SIGNATURE	STRUCTURAL ENG'S NAME AND SIGNATURE	BUILDER NAME AND SIGNATURE	DIGITAL SIGNATURE
RAM PRATAP SINGH MADA/ARC/0024/2019			