

GROUND FLOOR PLAN (Proposed) (SCALE 1:100)

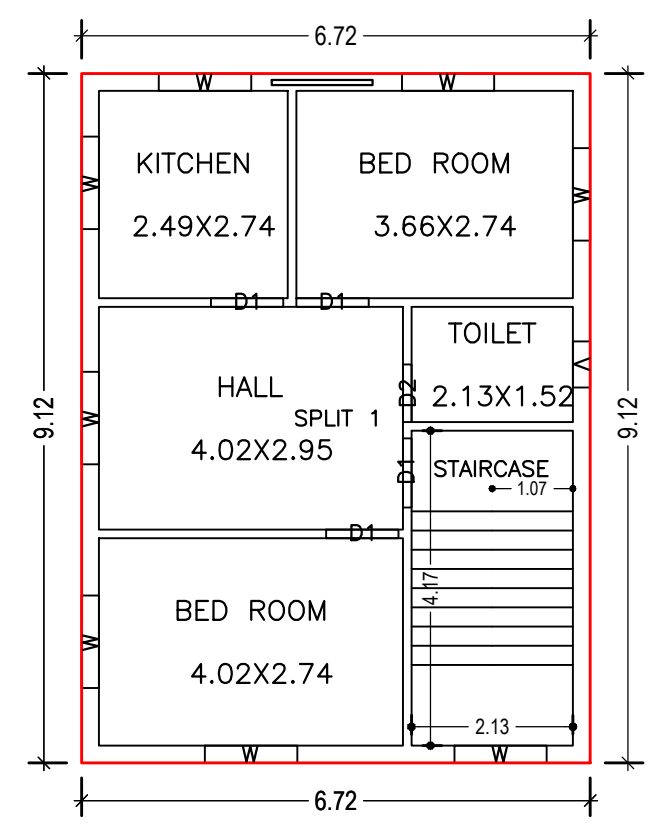

FIRST FLOOR PLAN (Proposed) (SCALE 1:100)

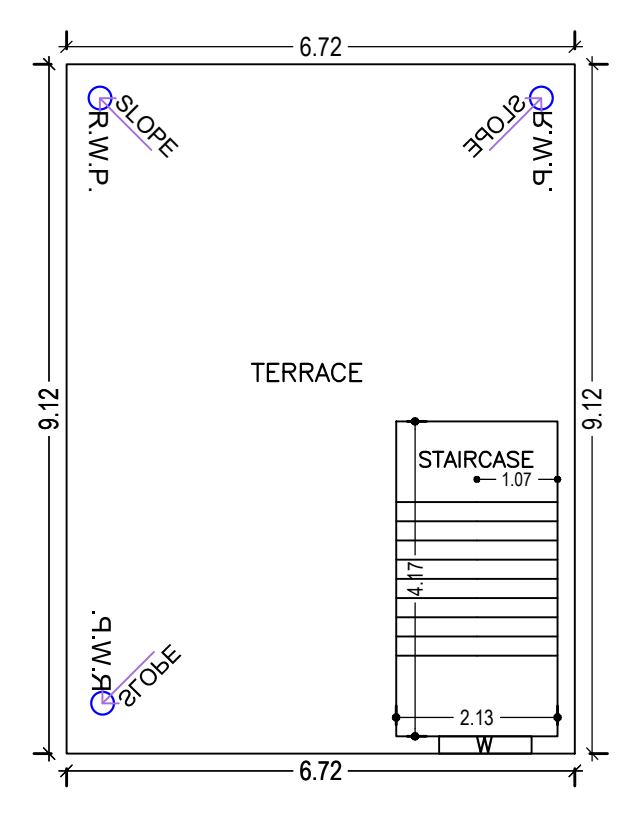

TERRACE FLOOR PLAN (SCALE 1:100)

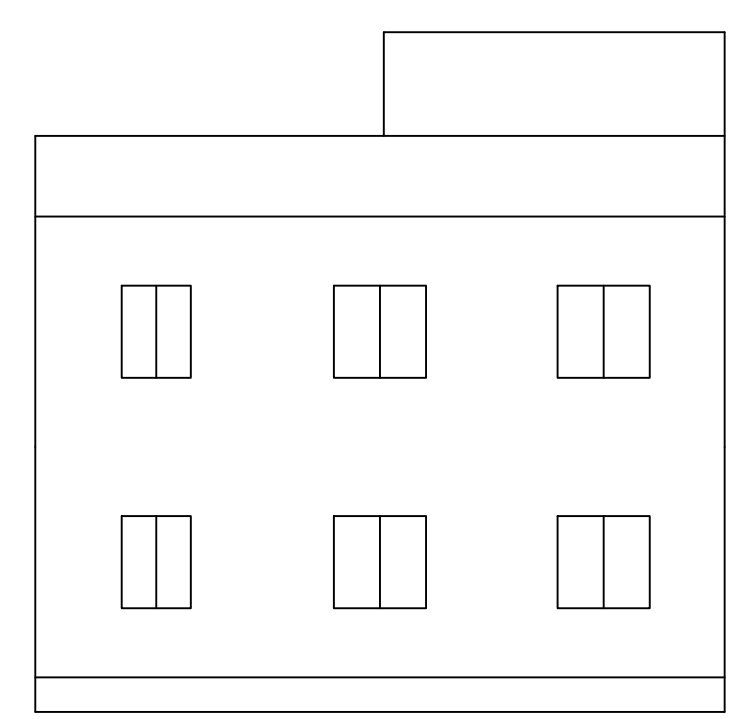

LEFT SIDE ELEVATION

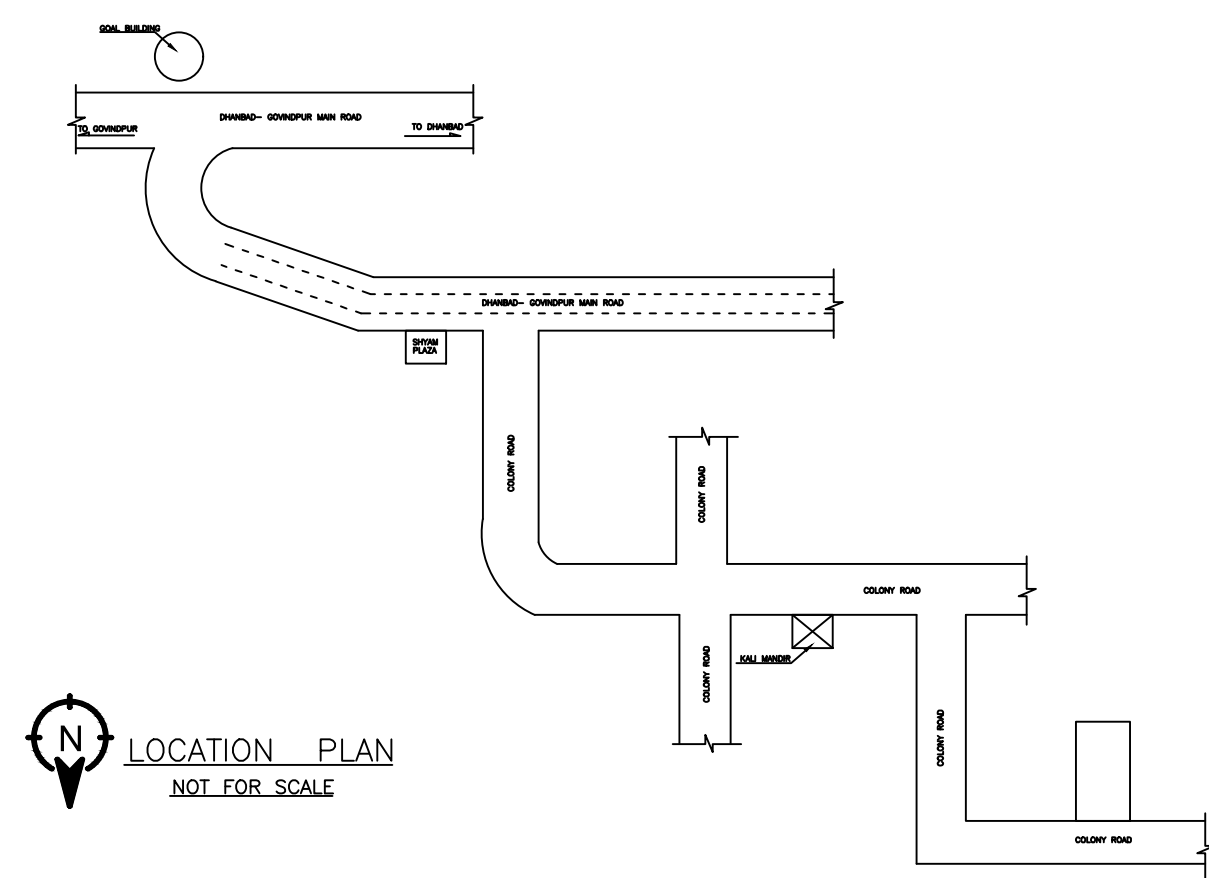

LOCATION PLAN NOT FOR SCALE

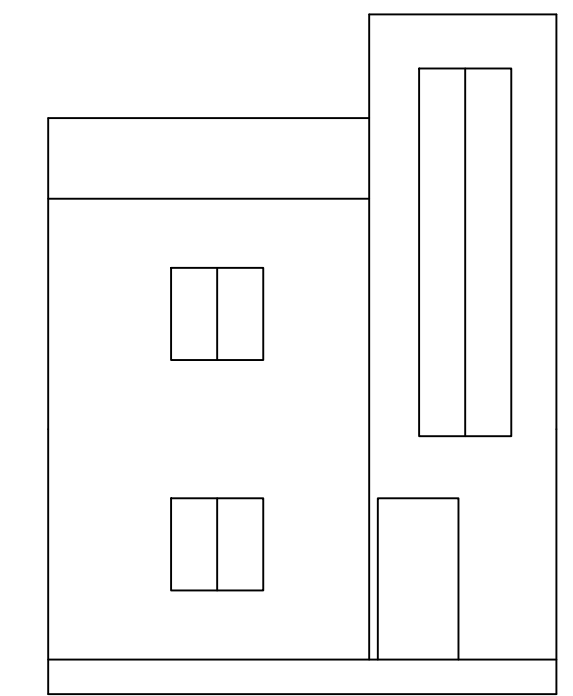

FRONT ELEVATION

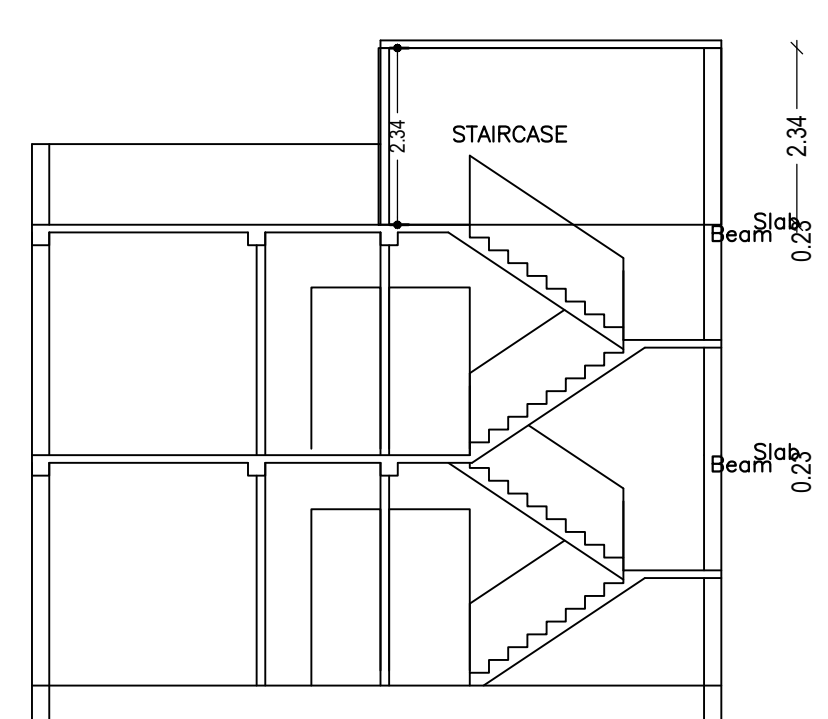

SECTION ON X-X

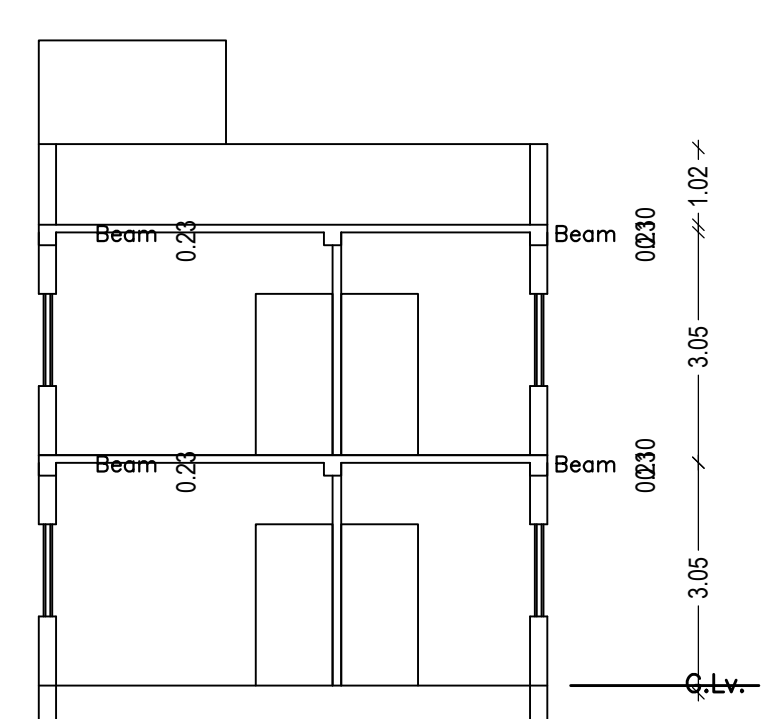

SECTION ON Y-Y

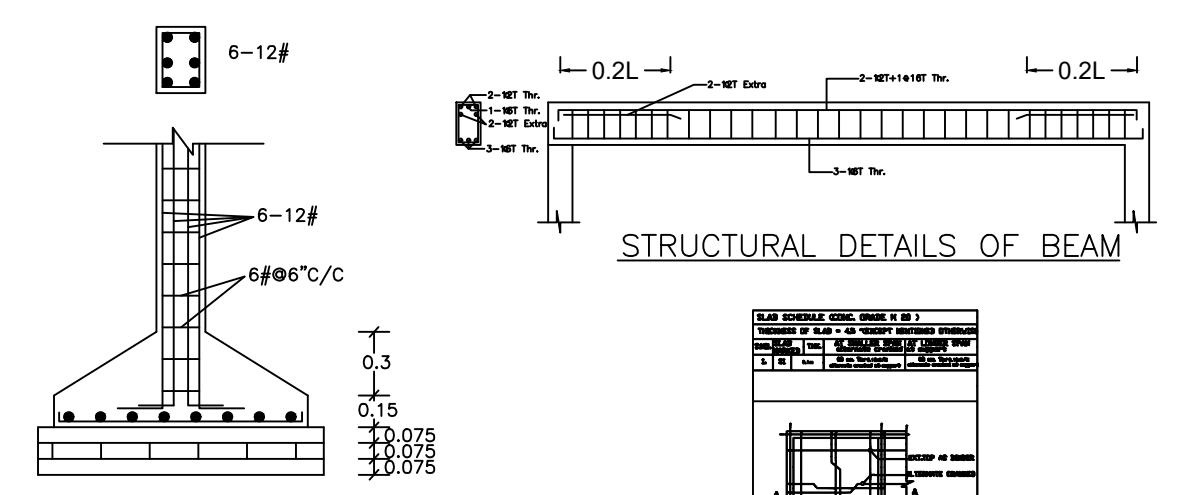

STRUCTURAL DETAILS OF BEAM

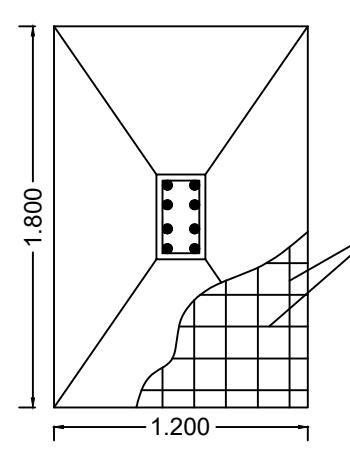

COLUMN DETAILS SCALE:- 1:50

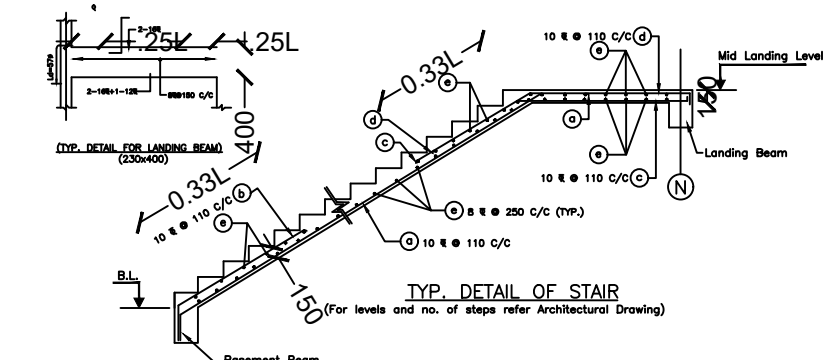

TYP. DETAIL OF STAIR (For levels and no. of steps refer Architectural Drawing)

Proposal Basic Information

Proposal File No.	MADA/BP/0255/2023
Owner Name	Smt. Ful Kumari
Khata No	23 ( OLD ) , 81 ( NEW )
Plot No	294 ( OLD ) , 345 ( NEW )
Village Name	Sabalpur
Use	Residential
SubUse	Bungalow/ Dwelling / Non Apartment

AREA STATEMENT MINERAL AREA DEVELOPMENT AUTHORITY	VERSION NO. : 1.0.66	SQ.MT.
PROJECT DETAIL:	VERSION DATE: 16/10/2020	
Region: JHARKHAND URBAN LOCAL BODIES	Plot Use: Residential	
District: DHANBAD	Plot SubUse: Bungalow/ Dwelling / Non Apartment	
Authority: MINERAL AREA DEVELOPMENT AUTHORITY	PlotNearby/ReligiousStructure: NA	
Inward No: MADA/BP/0255/2023	Plot/SubPlot No: 294 ( OLD ) , 345 ( NEW )	
Application Type: General Proposal	North: Road Width - 3.65 Wide Main Road	
Project Type: Building Permission	South: Plot No. - Plot No. 347	
Nature of Development: New	East: Plot No. - Part of this Plot	
Location of Development Area: Old Area	West: Plot No. - Part of this Plot	
AREA DETAILS:		
AREA OF PLOT (Minimum)	(A)	108.96
NET AREA OF PLOT(Gross Plot Area - Deduction from Gross Plot area)	(A-Deductions)	108.96
Deduction for Balance Plot Area(from Gross Plot Area)		
Common Plot		7.36
Total		7.36
BALANCE AREA OF PLOT(Net Plot Area - Recreational/Amenity space)	(A-Deductions)	101.61
PLOT AREA FOR COVERAGE(Net Plot Area)	(A-Deductions)	108.96
Plot Area for FAR (Net Plot Area + RoadWidening Area)	(A-Deductions)	108.96
COVERAGE CHECK		
Permissible Coverage area ( 70.00 % )		76.27
Proposed Coverage Area ( 56.28 % )		61.33
Total Prop. Coverage Area ( 56.28 % )		61.33
Balance coverage area ( 13.71 % )		14.94
FAR CHECK		
Perm. FAR Area ( 1.500 )		163.44
Total Perm. FAR area		163.44
Residential FAR		122.66
Proposed FAR Area		122.66
Total Proposed FAR Area		122.66
Consumed FAR (Factor)		1.13
Balance FAR Area		40.78
BUILT UP AREA CHECK		
Total Proposed BuiltUp Area		122.66
ARCHITECT (Regd)	MANISH AGARWAL	
ENGINEER (Regd)		
SUPERVISOR (Regd)		
OWNER (Regd)	Smt. Ful Kumari	
DEVELOPMENT AUTHORITY LOCAL BODY		

COLOR INDEX

PLOT BOUNDARY	Black
ABUTTING ROAD	Red
PROPOSED CONSTRUCTION	Green
COMMON PLOT	Yellow
ROAD WIDENING AREA	Blue
EXISTING (To be retained)	Light Blue
EXISTING (To be demolished)	White

Buildingwise Floor FAR Details

Floor Name	Building Name A (FUL KUMARI)		Total	
	Proposed Built Up Area (Sq.mt.)	Proposed FAR Area (Sq.mt.)	Total Proposed Built Up Area (Sq.mt.)	Total FAR Area (Sq.mt.)
Ground Floor	61.33	61.33	61.33	61.33
First Floor	61.33	61.33	61.33	61.33
Terrace Floor	0.00	0.00	0.00	0.00
Total :	122.66	122.66	122.66	122.66

Building USE/SUBUSE Details

Building Name	Building Use	Building SubUse	Building Structure
A (FUL KUMARI)	Residential	Bungalow/ Dwelling / Non Apartment	Non-Highrise

FAR & Tenement Details (Table 4c-1)

Building	No. of Same Bldg	Total Built Up Area (Sq.mt.)	Proposed FAR Area (Sq.mt.) Resi.	Total FAR Area (Sq.mt.)	Total Consumed Additional FAR Area (Sq.mt.)	Trmt (No.)
A (FUL KUMARI)	1	122.66	122.66	122.66	122.66	01
Grand Total :	1	122.66	122.66	122.66	122.66	01

UnitBUA Table for Building :A (FUL KUMARI)

FLOOR	Name	UnitBUA Type	UnitBUA Area	Carpet Area	No. of Rooms	No. of Tenement
GROUND FLOOR PLAN	SPLIT 1	FLAT	122.66	122.50	5	1
FIRST FLOOR PLAN	SPLIT 1	FLAT	0.00	0.00	5	0
Total:	-	-	122.66	122.50	10	1

Building :A (FUL KUMARI)

Floor Name	Total Built Up Area (Sq.mt.)	Proposed FAR Area (Sq.mt.) Resi.	Total FAR Area (Sq.mt.)	Total Consumed Additional FAR Area (Sq.mt.)	Trmt (No.)
Ground Floor	61.33	61.33	61.33	61.33	01
First Floor	61.33	61.33	61.33	61.33	00
Terrace Floor	0.00	0.00	0.00	0.00	00
Total :	122.66	122.66	122.66	122.66	01
Total Number of Same Buildings	1				
Total :	122.66	122.66	122.66	122.66	01

SCHEDULE OF DOOR:

BUILDING NAME	NAME	LENGTH	HEIGHT	NOS
A (FUL KUMARI)	D2	0.76	2.10	02
A (FUL KUMARI)	D1	0.91	2.10	02
A (FUL KUMARI)	D1	0.96	2.10	06

SCHEDULE OF WINDOW/VENTILATION:

BUILDING NAME	NAME	LENGTH	HEIGHT	NOS
A (FUL KUMARI)	V	0.61	0.60	02
A (FUL KUMARI)	W	1.22	1.20	15

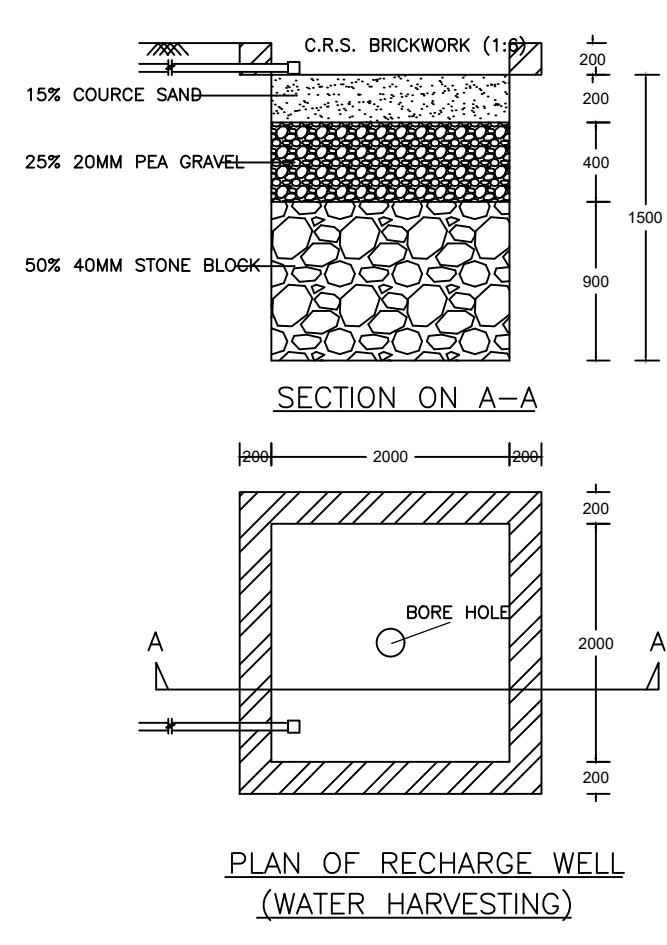
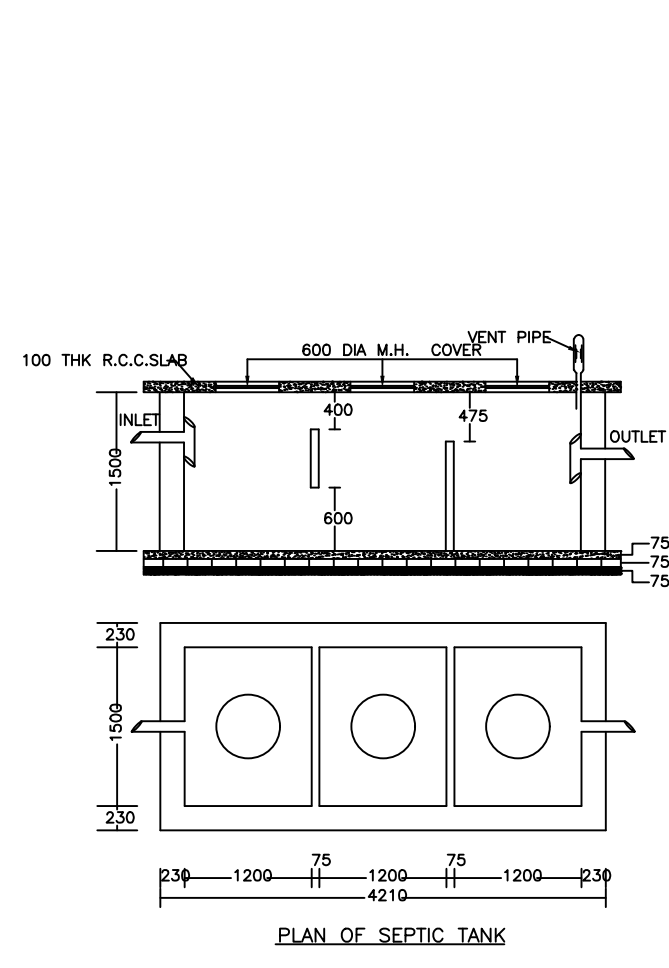

PLAN OF RECHARGE WELL (WATER HARVESTING)

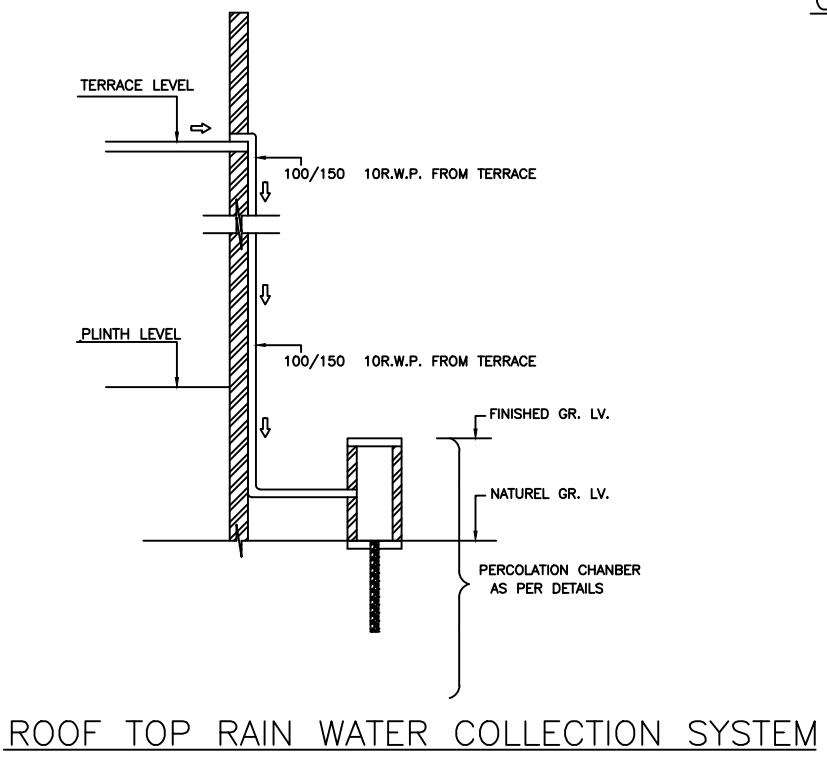

ROOF TOP RAIN WATER COLLECTION SYSTEM

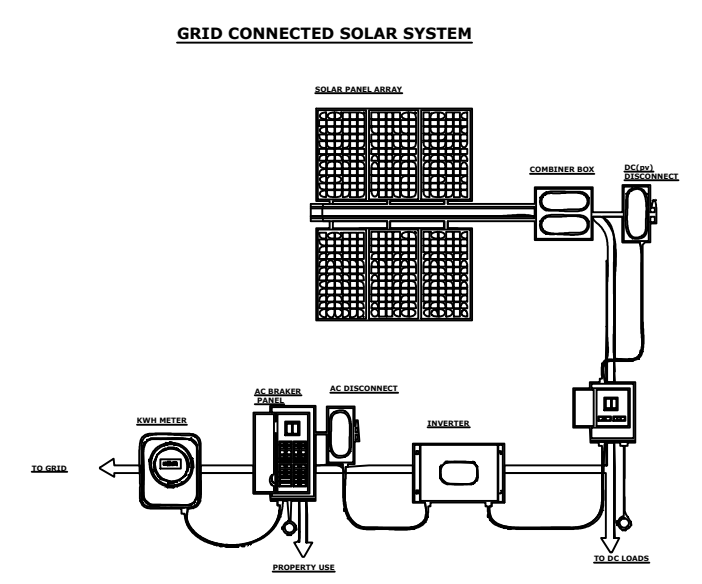

GRID CONNECTED SOLAR SYSTEM

LTP NAME AND SIGNATURE	STRUCTURAL ENG'S NAME AND SIGNATURE	BUILDER NAME AND SIGNATURE	DIGITAL SIGNATURE
MANISH AGARWAL MADA/ARC/0008/2020			