

GROUND FLOOR PLAN (Proposed) SCALE 1:100

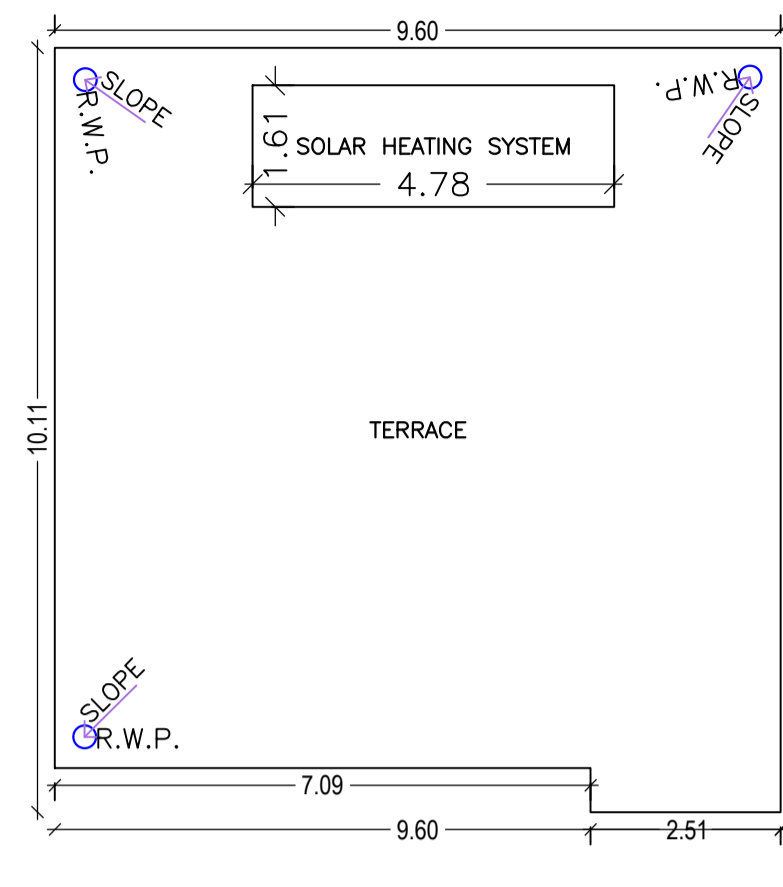

TERRACE FLOOR PLAN (SCALE 1:100)

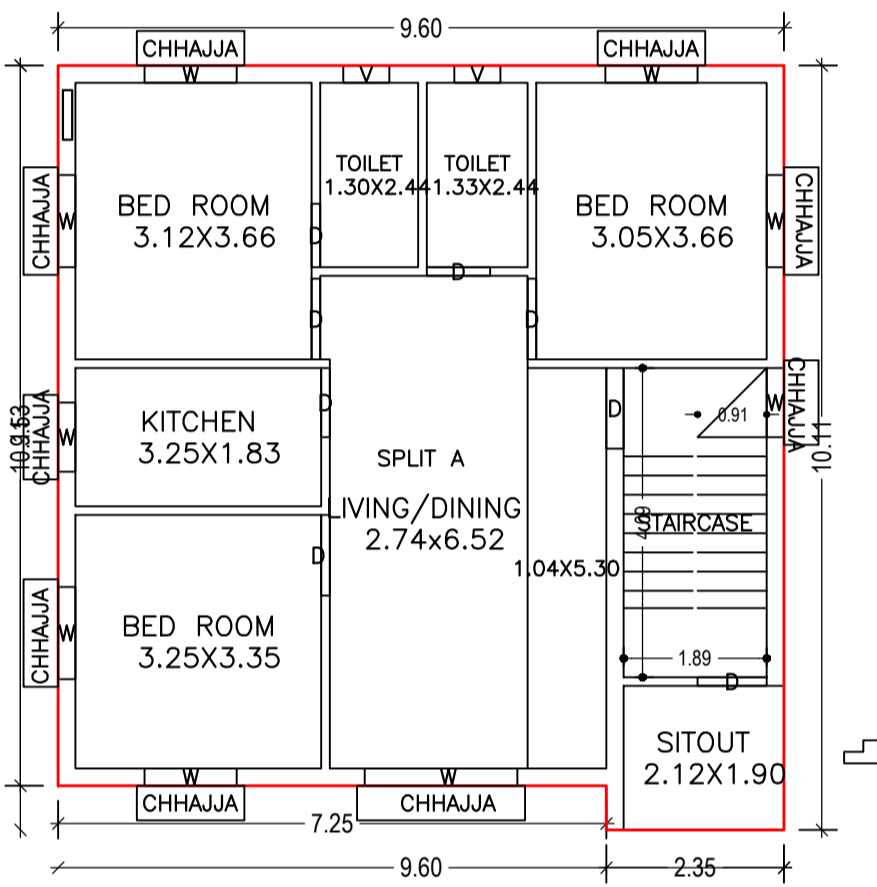

FIRST FLOOR PLAN (Proposed) SCALE 1:100

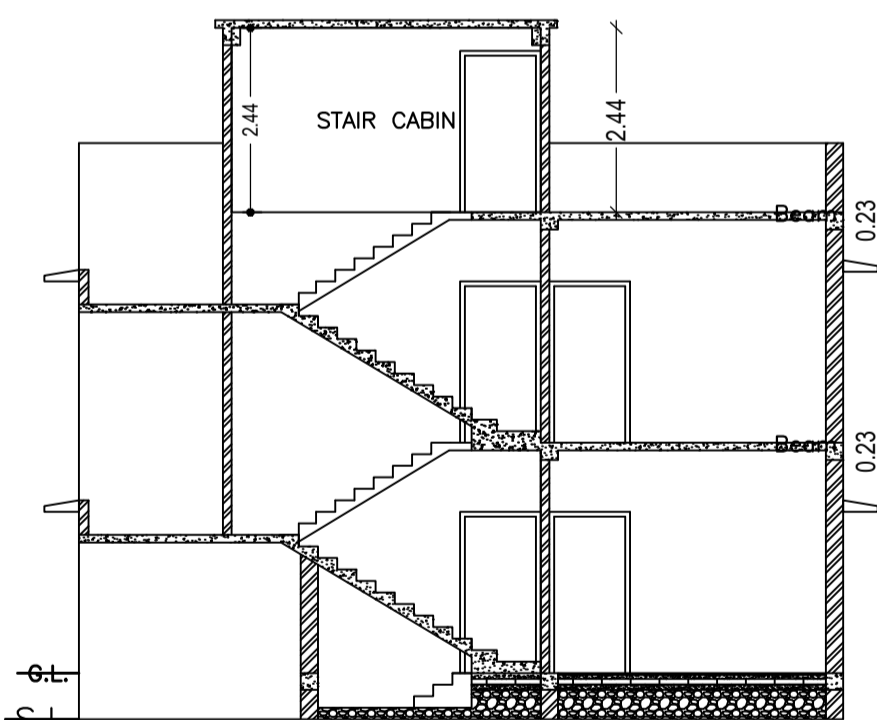

SECTION - XX' SCALE - 1" = 8'-0"

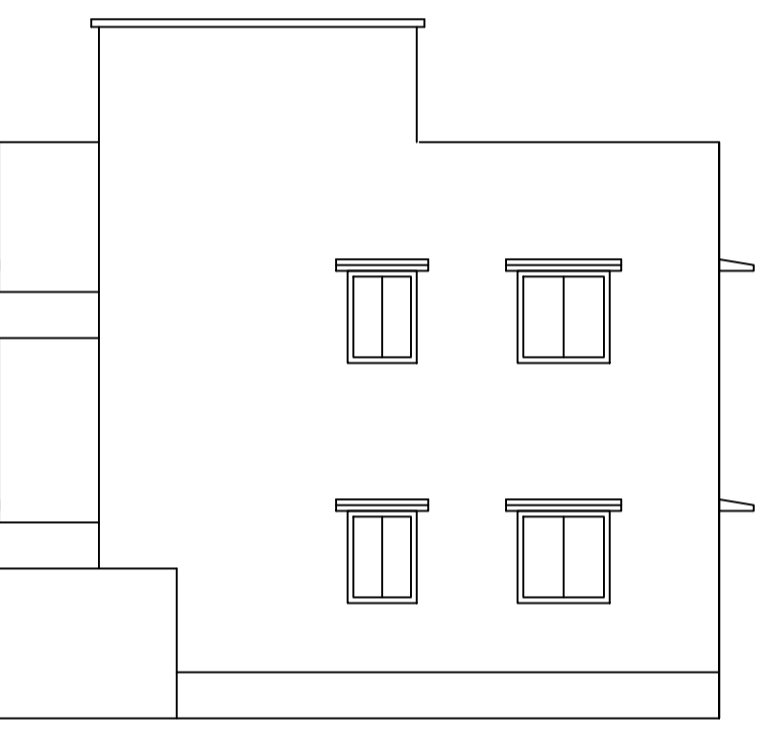

RIGHT SIDE ELEVATION SCALE - 1" = 8'-0"

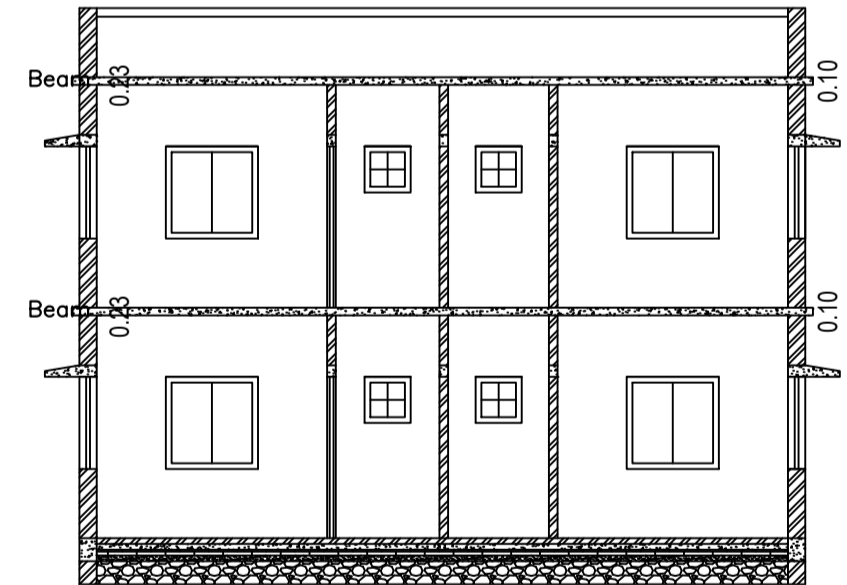

SECTION - YY' SCALE - 1" = 8'-0"

Building :A (MD FIROZ ALAM)

Floor Name	Total Built Up Area (Sq.mt.)	Proposed FAR Area (Sq.mt.)	Total FAR Area (Sq.mt.)	Total Consumed Additional FAR Area (Sq.mt.)	Tnmt (No.)
Ground Floor	92.82	92.82	92.82	92.82	01
First Floor	92.82	92.82	92.82	92.82	00
Terrace Floor	0.00	0.00	0.00	0.00	00
Total :	185.64	185.64	185.64	185.64	01
Total Number of Same Buildings	1				
Total :	185.64	185.64	185.64	185.64	01

SCHEDULE OF DOOR:

BUILDING NAME	NAME	LENGTH	HEIGHT	NOS
A (MD FIROZ ALAM)	D	0.84	2.10	04
A (MD FIROZ ALAM)	D	0.91	2.10	04
A (MD FIROZ ALAM)	D	1.07	2.10	08
A (MD FIROZ ALAM)	D	1.23	2.10	01

SCHEDULE OF WINDOW/VENTILATION:

BUILDING NAME	NAME	LENGTH	HEIGHT	NOS
A (MD FIROZ ALAM)	V	0.61	1.20	04
A (MD FIROZ ALAM)	W	0.91	1.20	04
A (MD FIROZ ALAM)	W	1.22	1.20	12
A (MD FIROZ ALAM)	W	2.02	1.20	02

FAR & Tenement Details (Table 4c-1)

Building	No. of Same Bldg	Total Built Up Area (Sq.mt.)	Proposed FAR Area (Sq.mt.)	Total FAR Area (Sq.mt.)	Total Consumed Additional FAR Area (Sq.mt.)	Tnmt (No.)
A (MD FIROZ ALAM)	1	185.64	185.64	185.64	185.64	01
Grand Total :	1	185.64	185.64	185.64	185.64	01

Building USE/SUBUSE Details

Building Name	Building Use	Building SubUse	Building Structure
A (MD FIROZ ALAM)	Residential	Bungalow/ Dwelling / Non Apartment	Non-Highrise

Buildingwise Floor FAR Details

Floor Name	Building Name A (MD FIROZ ALAM)		Total	
	Proposed Built Up Area (Sq.mt.)	Proposed FAR Area (Sq.mt.)	Total Proposed Built Up Area (Sq.mt.)	Total FAR Area (Sq.mt.)
Ground Floor	92.82	92.82	92.82	92.82
First Floor	92.82	92.82	92.82	92.82
Terrace Floor	0.00	0.00	0.00	0.00
Total :	185.64	185.64	185.64	185.64

COLOR INDEX

- PLOT BOUNDARY
- ABUTTING ROAD
- PROPOSED CONSTRUCTION
- COMMON PLOT
- ROAD WIDENING AREA
- EXISTING (To be retained)
- EXISTING (To be demolished)

AREA STATEMENT MINERAL AREA DEVELOPMENT AUTHORITY		VERSION NO: 1.0.67	VERSION DATE: 16/10/2020
PROJECT DETAIL:			
Region: JHARKHAND URBAN LOCAL BODIES	District: DHANBAD	Plot Use: Residential	Plot SubUse: Bungalow/ Dwelling / Non Apartment
Authority: MINERAL AREA DEVELOPMENT AUTHORITY	Inward No: MADA/BP/0211/2023	Plot/SubPlot No: OLD PLOT NO-1315 & 1319, NEW PLOT NO-1363	Plot/Nearby/Religious Structure: NA
Application Type: General Proposal	Project Type: Building Permission	Nature of Development: New	Location of Development Area: Old Area
AREA DETAILS:		SQ. MT.	
AREA OF PLOT (Minimum)		(A) 157.71	
NET AREA OF PLOT (Gross Plot Area - Deduction from Gross Plot Area)		(A-Deductions) 157.71	
Deduction for Balance Plot Area (from Gross Plot Area)			
Common Plot		18.79	
Total		18.79	
BALANCE AREA OF PLOT (Net Plot Area - Recreational/Amenity space)		(A-Deductions) 138.92	
PLOT AREA FOR COVERAGE (Net Plot Area)		(A-Deductions) 157.71	
Plot Area for FAR (Net Plot Area + Road Widening Area)		(A-Deductions) 157.71	
COVERAGE CHECK			
Permissible Coverage area (70.00 %)		110.40	
Proposed Coverage Area (58.86 %)		92.82	
Total Prop. Coverage Area (58.86 %)		92.82	
Balance coverage area (11.15 %)		17.58	
FAR CHECK			
Perm. FAR Area (2.500)		394.28	
Total Perm. FAR area		394.28	
Residential FAR		185.65	
Proposed FAR Area		185.65	
Total Proposed FAR Area		185.65	
Consumed FAR (Factor)		1.18	
Balance FAR Area		208.63	
BUILT UP AREA CHECK			
Total Proposed BuiltUp Area		185.64	
ARCHITECT (Regd)		RAM PRATAP SINGH	
ENGINEER (Regd)			
SUPERVISOR (Regd)		MD. FIROJ ALAM	
OWNER (Regd)			
DEVELOPMENT AUTHORITY		LOCAL BODY	

UnitBUA Table for Building :A (MD FIROZ ALAM)

FLOOR	Name	UnitBUA Type	UnitBUA Area	Carpet Area	No. of Rooms	No. of Tenement
GROUND FLOOR PLAN	SPLIT A	FLAT	185.65	185.50	8	1
FIRST FLOOR PLAN	SPLIT A	FLAT	0.00	0.00	8	0
Total:	-	-	185.65	185.50	16	1

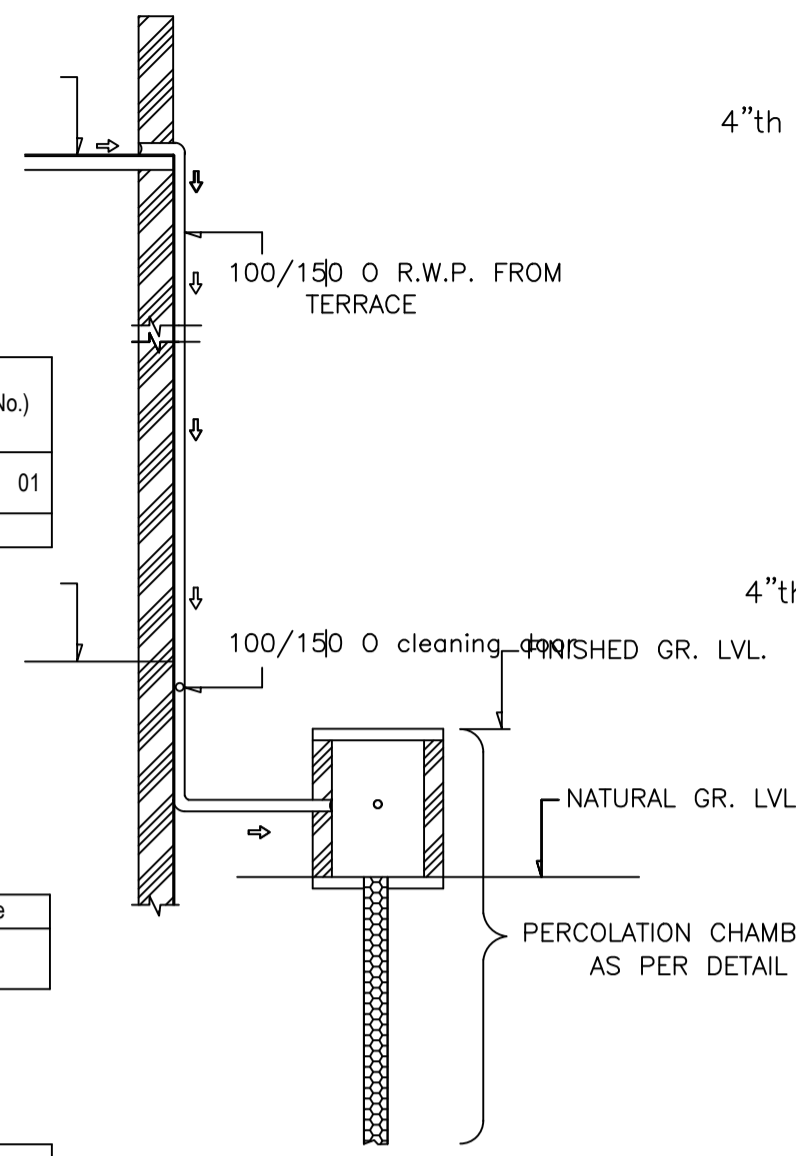

SCALE = 1" = 4'-0"

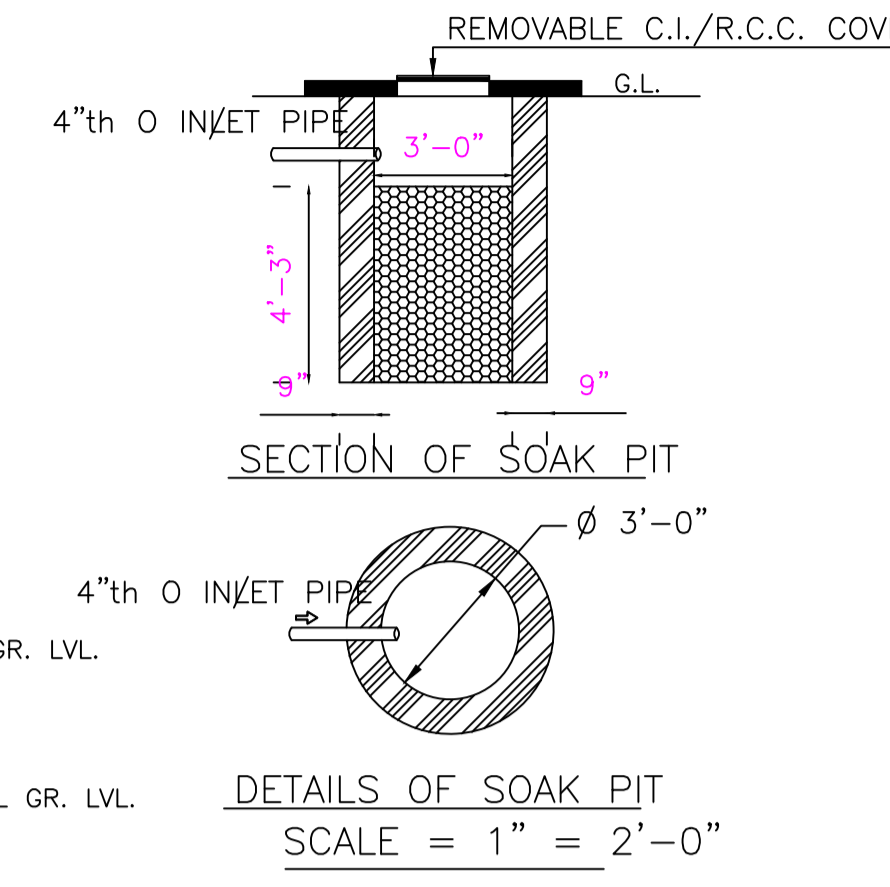

SCALE = 1" = 2'-0"

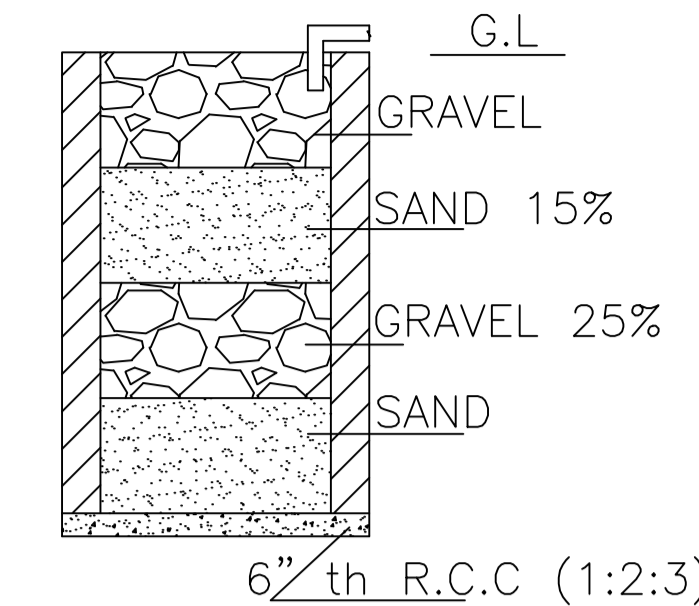

SECTION ON A - B

DETAILS DRAWING OF RAIN WATER HARVESTING SCALE:- 1"=2'-0"

Proposal Basic Information

Proposal File No.	MADA/BP/0211/2023
Owner Name	MD. FIROJ ALAM
Khata No	OLD KHATA NO-41, NEW KHATA NO-114
Plot No	OLD PLOT NO-1315 & 1319, NEW PLOT NO-1363
Village Name	Kurmidih
Use	Residential
SubUse	Bungalow/ Dwelling / Non Apartment



FRONT ELEVATION SCALE - 1" = 8'-0"

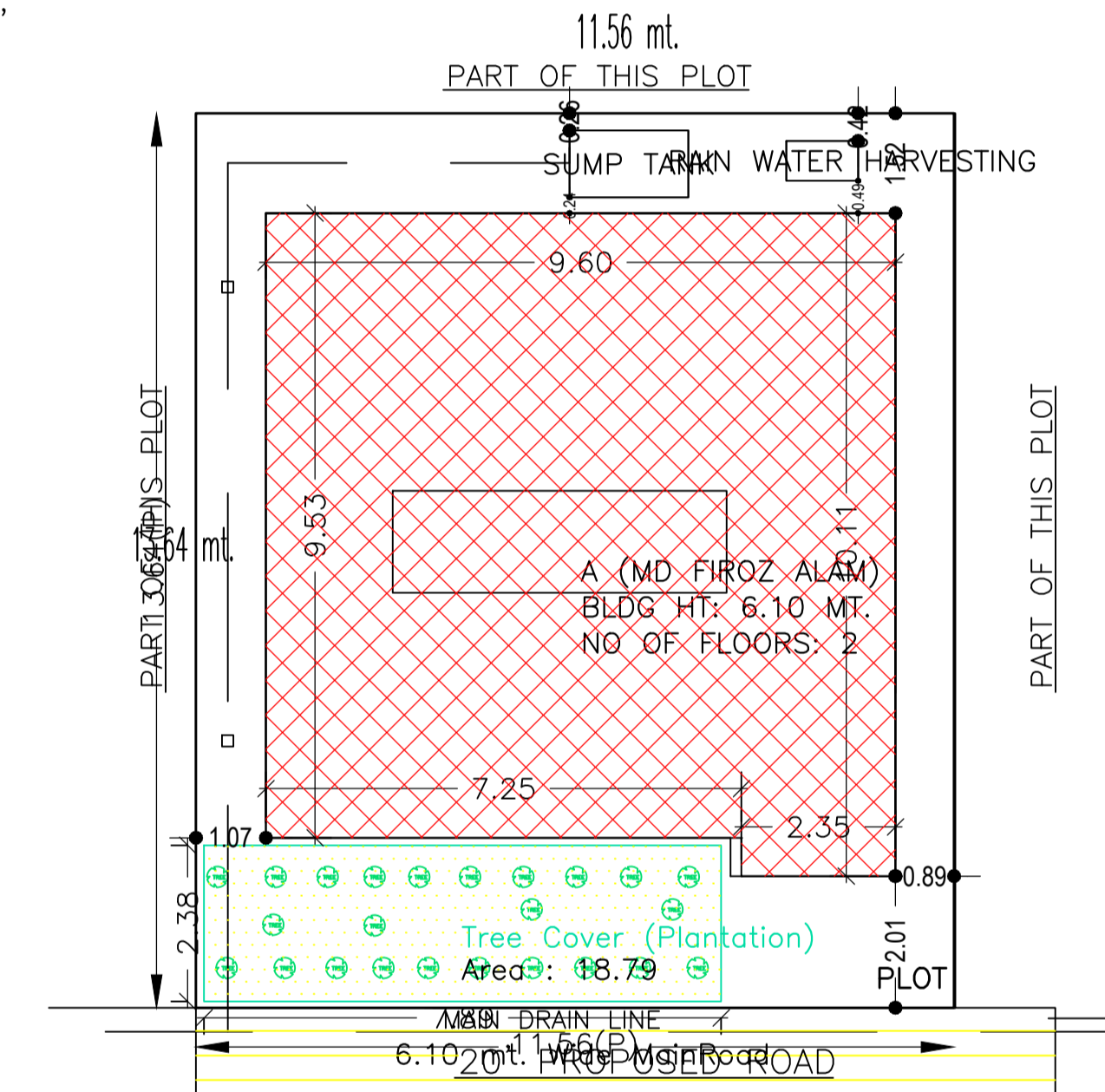

SITE PLAN SCALE - 1" = 8'-0"

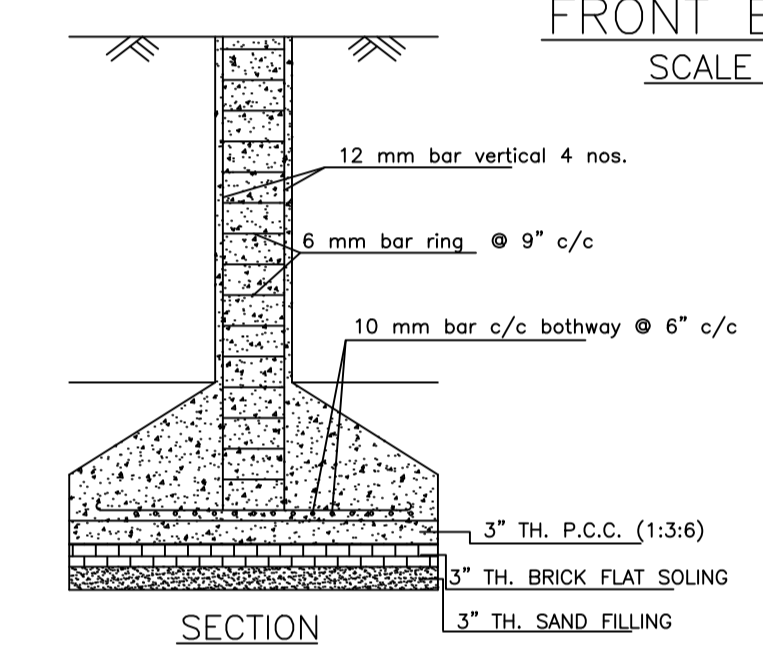

DETAILS OF COLUMN FOUNDATION SCALE - 1" = 2'-0"

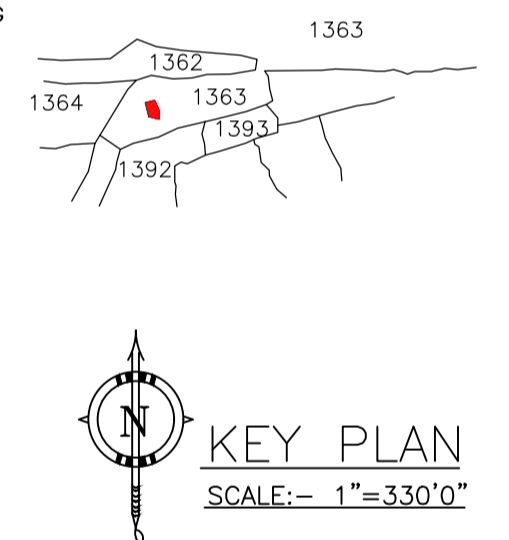

KEY PLAN SCALE:- 1"=330'-0"

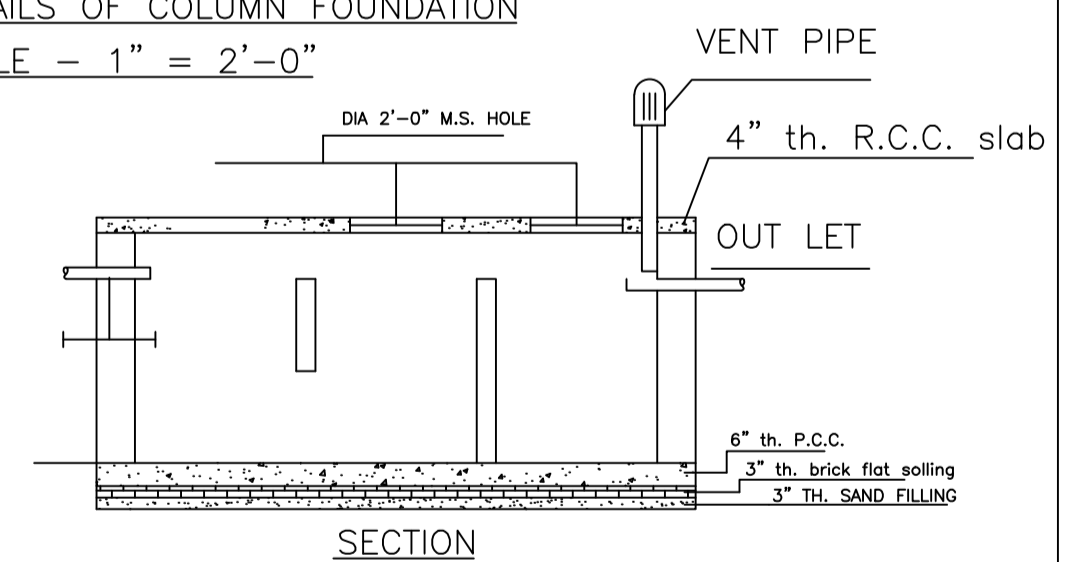

DETAILS OF SEPTIC TANK SCALE - 1" = 4'-0"

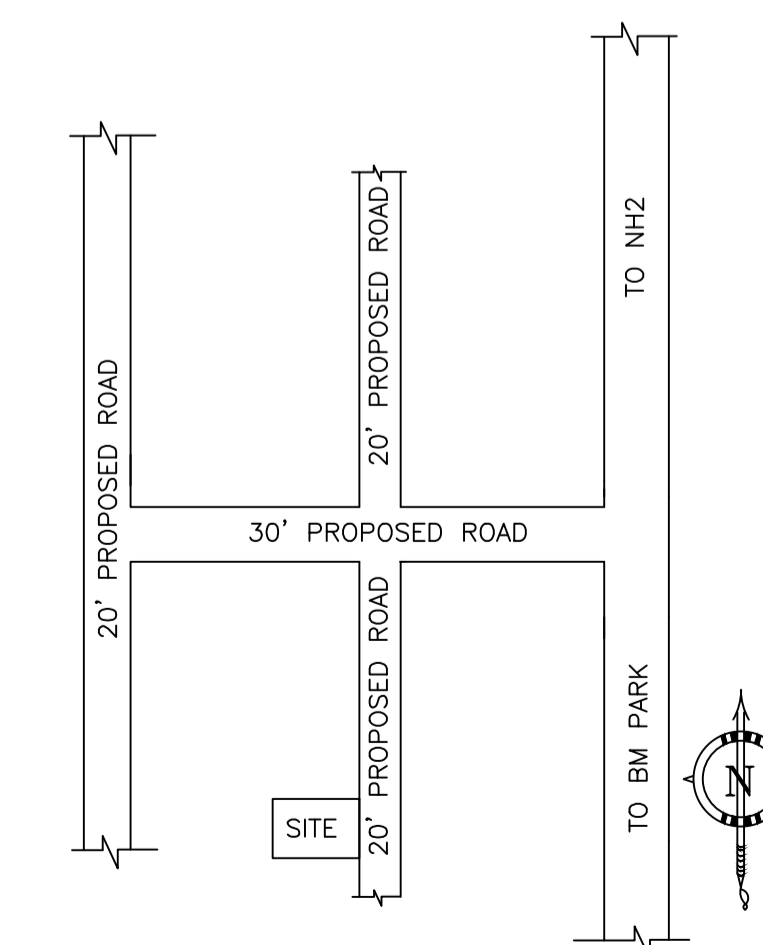

LOCATION PLAN NOT TO SCALE

LTP NAME AND SIGNATURE	STRUCTURAL ENG'S NAME AND SIGNATURE	BUILDER NAME AND SIGNATURE	DIGITAL SIGNATURE
RAM PRATAP SINGH MADA/ARC/0024/2019			