

DETAILS OF SEPTIC TANK

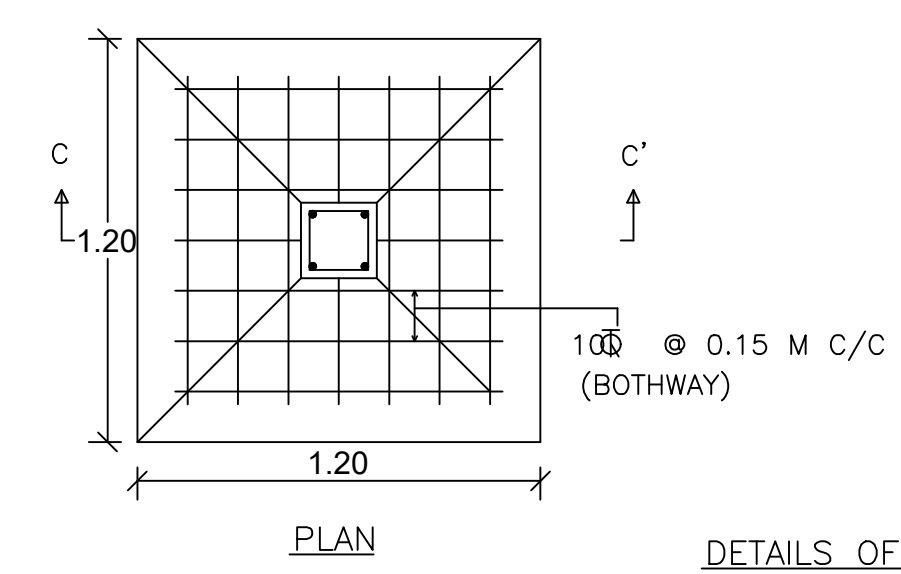

DETAILS OF FOUNDATION

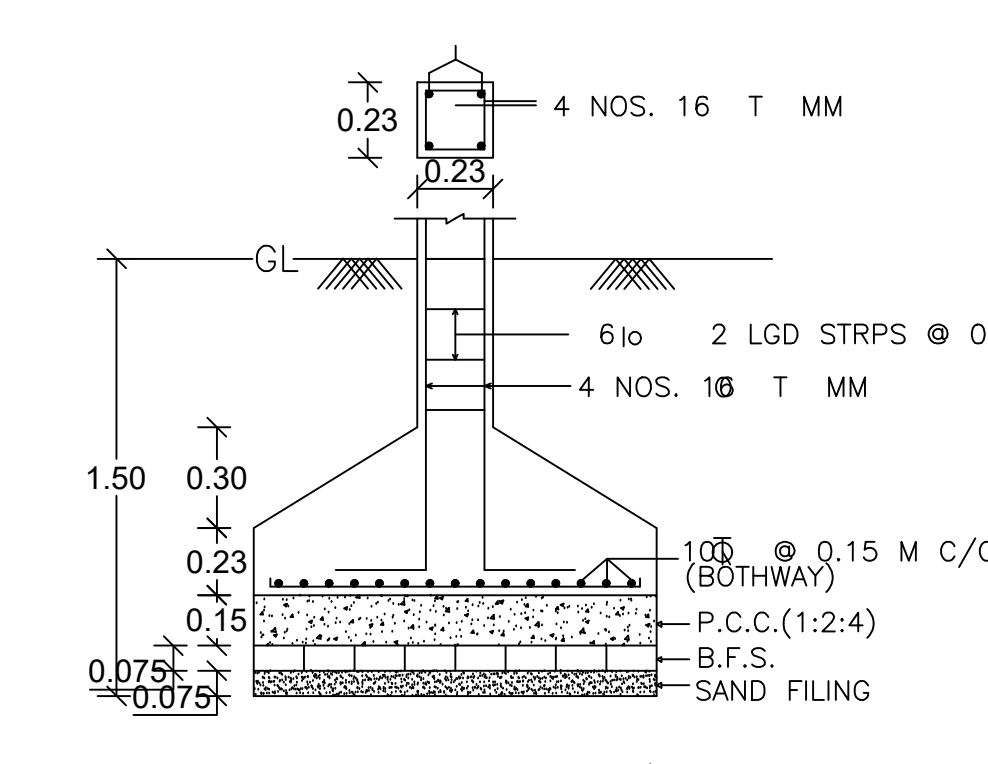

SECTION ON C-C'

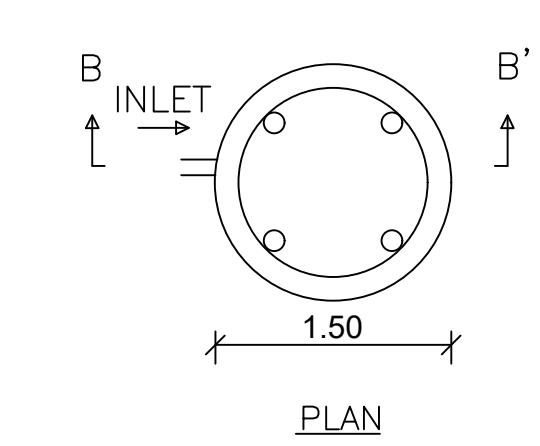

DETAILS OF WATER HARVESTING

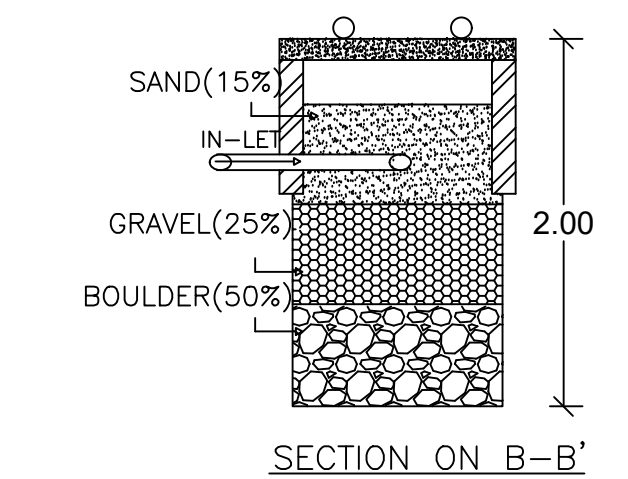

SECTION ON B-B'

Proposal Basic Information

Proposal File No.	MADA/BP/0256/2023
Owner Name	RINA KUMARI
Khata No.	9
Plot No.	1576, 1579
Village Name	Telufa
Use	Residential
SubUse	Bungalow Dwelling / Non Apartment

AREA STATEMENT MINERAL

AREA STATEMENT MINERAL	VERSION NO. : 1.0.06
AREA DEVELOPMENT AUTHORITY	VERSION DATE: 16/10/2023
PROJECT DETAIL	Plot Use: Residential
Region: BHARHUNG URBAN LOCAL BODIES	Plot SubUse: Bungalow Dwelling / Non Apartment
District: DHARWAD	Plot/Religious/Structure: NA
Authority: MINERAL AREA DEVELOPMENT AUTHORITY	Plot/Religious/Structure: NA
Inward No: MADABP/0256/2023	North Plot No. - 44
Application Type: General Proposal	South Plot No. - 42
Project Type: Building Permission	East Road Width: 4.87 M ROAD
Nature of Development: New	West Plot No. - 29
Location of Development Area: Old	
Area	SQ.MT.
AREA DETAILS	
AREA OF PLOT (Minimum)	401.06
NET AREA OF PLOT (Gross Plot Area - Deduction from Gross Plot Area)	401.06
Deduction for Balance Plot Area (from Gross Plot Area)	56.83
Common Plot	56.83
Total	56.83
BALANCE AREA OF PLOT (Net Plot Area - Recreational/Amenity space)	344.23
FLOOR AREA FOR COVERAGE (Net Plot Area)	401.06
Plot Area for FAR (Net Plot Area - Road/Widening Area)	401.06
COVERAGE CHECK	
Permissible Coverage area (60.00 %)	240.64
Proposed Coverage Area (58.13 %)	237.15
Total Prop. Coverage Area (58.13 %)	237.15
Balance coverage area (0.87 %)	3.48
FAR CHECK	
Perm. FAR Area (1.800)	721.91
Total Perm. FAR area	721.91
Residential FAR	432.20
Proposed FAR Area	432.20
Total Proposed FAR Area	432.20
Consumed FAR (Factor)	1.08
Balance FAR Area	289.71
BUILT UP AREA CHECK	
Total Proposed Built Up Area	432.19
ARCHITECT (Regd)	TRILCHAN KUMAR TRVEDI
ENGINEER (Regd)	
SUPERVISOR (Regd)	
OWNER (Regd)	RINA KUMARI
DEVELOPMENT AUTHORITY	LOCAL BODY

COLOR INDEX

ABUTTING ROAD	Green
PROPOSED CONSTRUCTION	Red
COMMON PLOT	Yellow
ROAD WIDENING AREA	Blue
EXISTING (To be retained)	Black
EXISTING (To be demolished)	White

Buildingwise Floor FAR Details

Floor Name	Building Name A (RESIDENTIAL)		Total	
	Proposed Built Up Area (Sq.mt)	Proposed FAR Area (Sq.mt)	Total Proposed Built Up Area (Sq.mt)	Total FAR Area (Sq.mt)
Ground Floor	237.15	237.15	237.15	237.15
First Floor	195.04	195.04	195.04	195.04
Terrace Floor	0.00	0.00	0.00	0.00
Total	432.19	432.19	432.19	432.19

Building USE/SUBUSE Details

Building Name	Building Use	Building SubUse	Building Structure
A (RESIDENTIAL)	Residential	Bungalow Dwelling / Non Apartment	Non-Highrise

FAR & Tenement Details (Table 4c-1)

Building	No. of Same Bldg	Gross Built Up Area (Sq.mt)	Deductions From Gross BUA/Area in Sq.mt.	Total Built Up Area (Sq.mt)	Proposed FAR Area (Sq.mt)	Total FAR Area (Sq.mt)	Total Consumed Additional FAR Area (Sq.mt)	Tenement (No.)
A (RESIDENTIAL)	1	432.21	0.02	432.19	432.19	432.19	432.19	01
Grand Total	1	432.21	0.02	432.19	432.19	432.19	432.19	01

Building :A (RESIDENTIAL)

Floor Name	Gross Built Up Area	Deductions From Gross BUA/Area in Sq.mt.	Total Built Up Area (Sq.mt)	Proposed FAR Area (Sq.mt)	Total FAR Area (Sq.mt)	Total Consumed Additional FAR Area (Sq.mt)	Tenement (No.)
Ground Floor	240.16	3.01	237.15	237.15	237.15	237.15	01
First Floor	195.05	3.01	195.04	195.04	195.04	195.04	00
Terrace Floor	0.00	0.00	0.00	0.00	0.00	0.00	00
Total	435.21	6.02	432.19	432.19	432.19	432.19	01
Total Number of Same Buildings	1						
Total	435.21	6.02	432.19	432.19	432.19	432.19	01

SCHEDULE OF DOOR:

BUILDING NAME	NAME	LENGTH	HEIGHT	NOS
A (RESIDENTIAL)	DT	0.75	2.10	16
A (RESIDENTIAL)	D	1.00	2.10	16

SCHEDULE OF WINDOW/VENTILATION:

BUILDING NAME	NAME	LENGTH	HEIGHT	NOS
A (RESIDENTIAL)	V	0.80	1.20	12
A (RESIDENTIAL)	W	1.00	1.20	02
A (RESIDENTIAL)	W	1.13	1.20	02
A (RESIDENTIAL)	W	1.20	1.20	15

UnitBUA Table for Building :A (RESIDENTIAL)

FLOOR	Name	UnitBUA Type	UnitBUA Area	Carpet Area	No. of Rooms	No. of Tenement
GROUND FLOOR PLAN	SPLIT 1	FLAT	432.20	432.09	19	1
FIRST FLOOR PLAN	SPLIT 1	FLAT	0.00	0.00	17	0
Total			432.20	432.09	36	1

LTP NAME AND SIGNATURE	STRUCTURAL ENG'S NAME AND SIGNATURE	BUILDER NAME AND SIGNATURE	DIGITAL SIGNATURE
TRILCHAN KUMAR TRVEDI MADA/DTM/0030/2019			