

Project Title: SMT POONAM SINGH

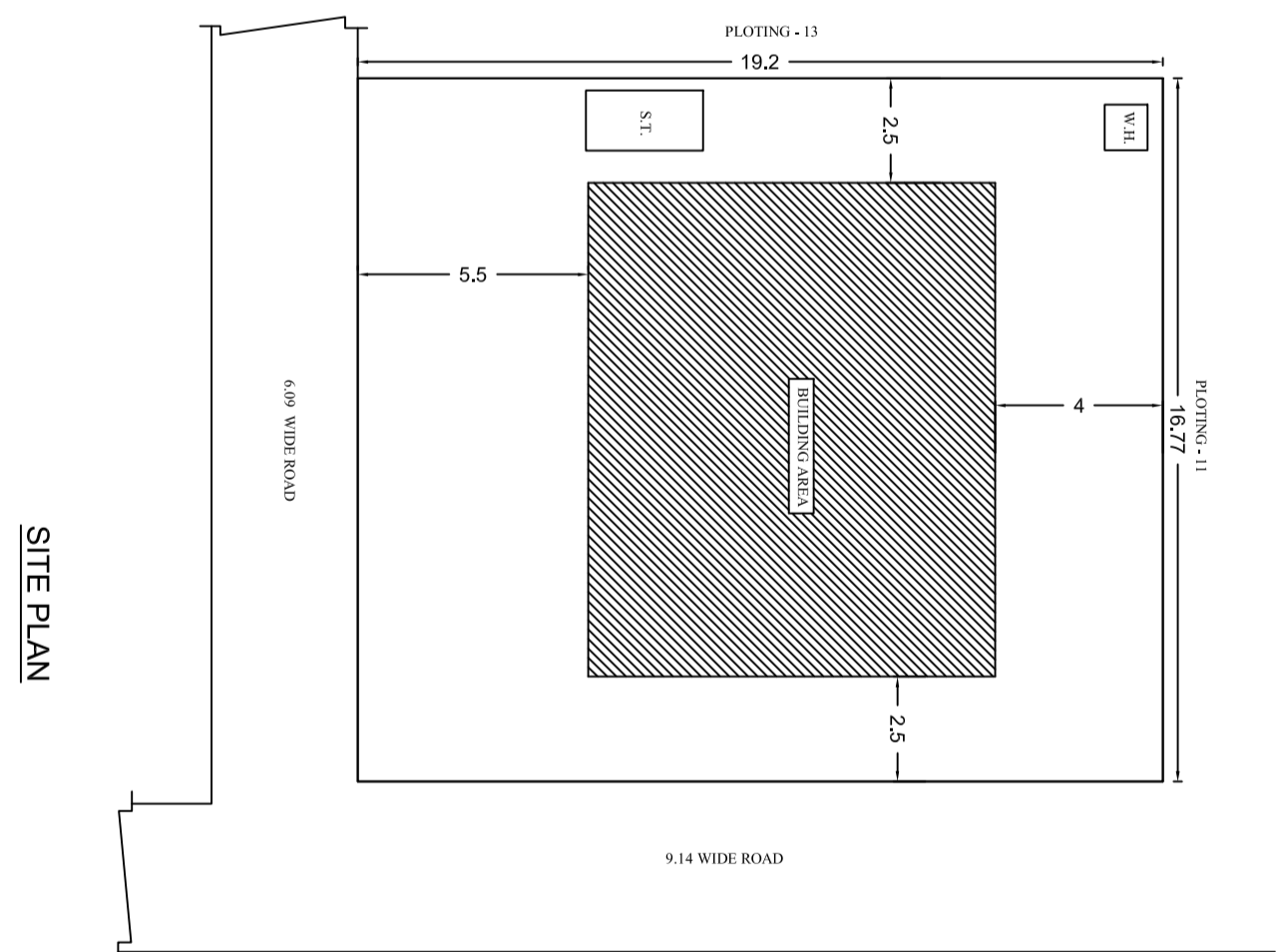
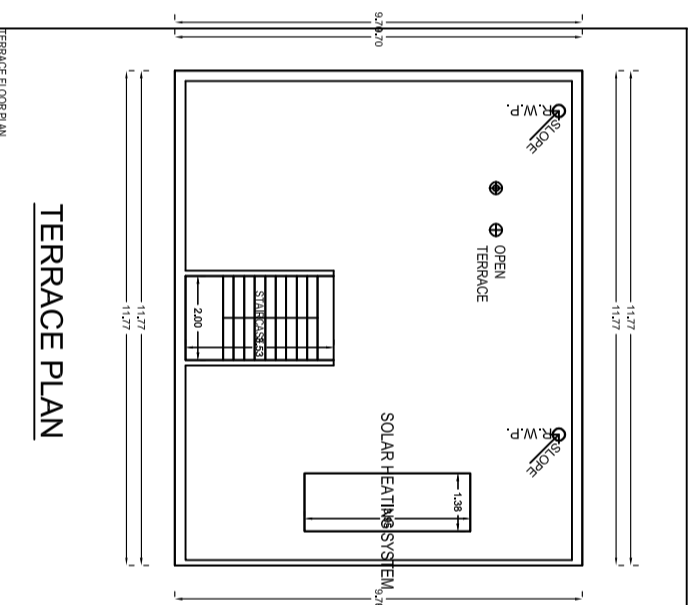
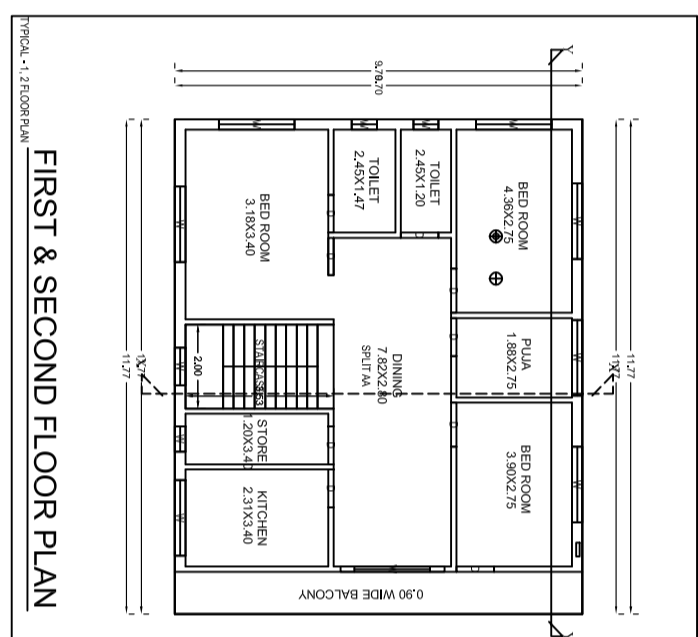
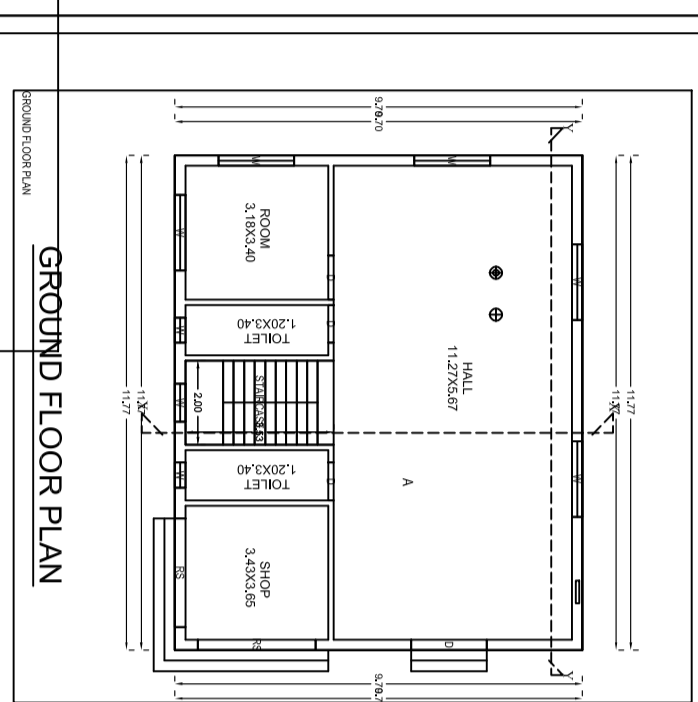
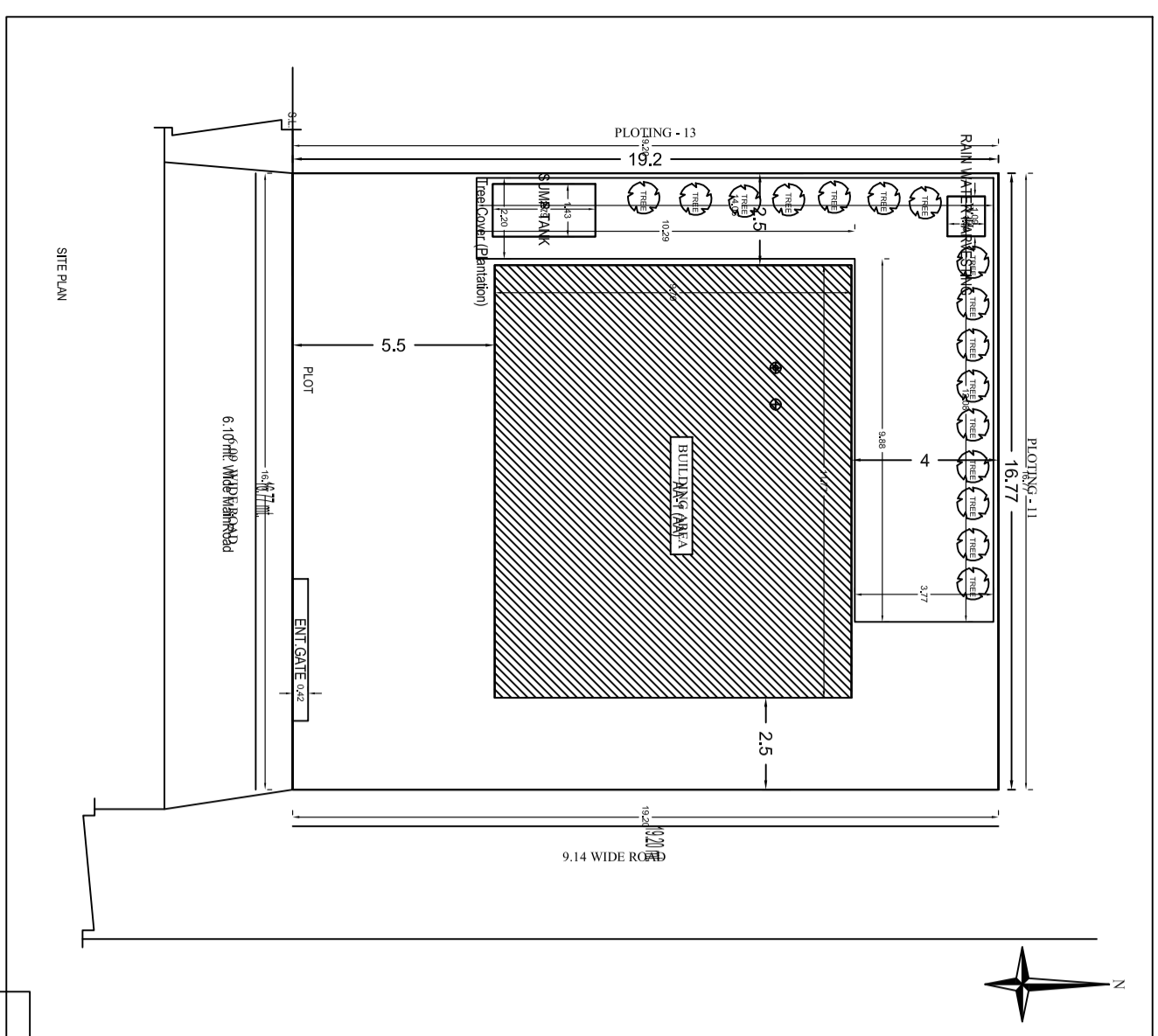
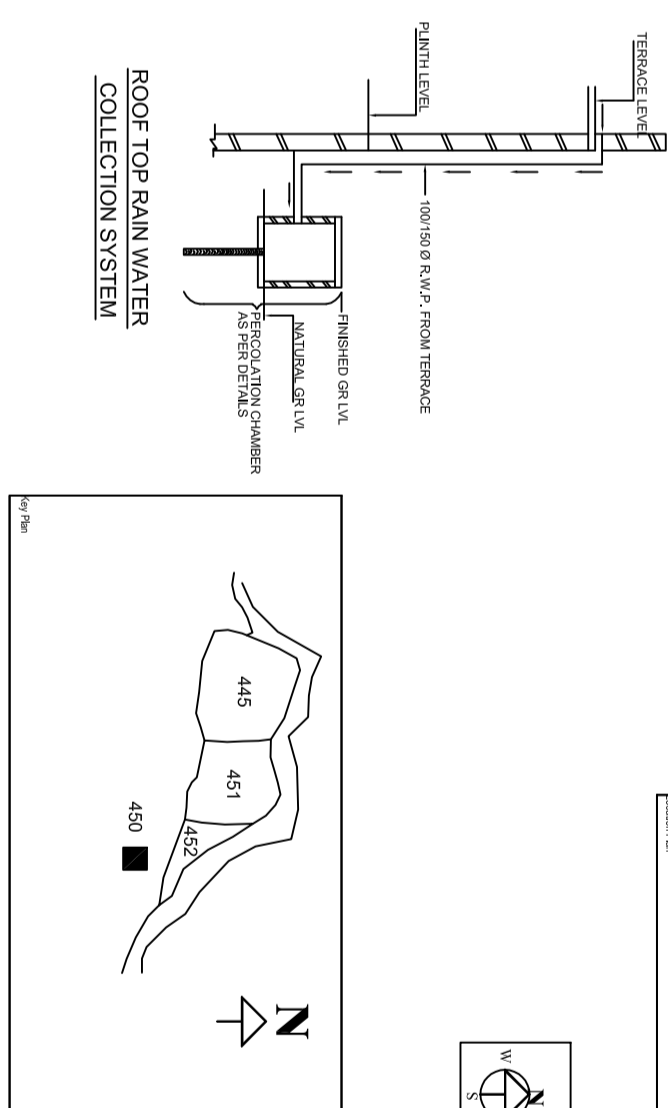
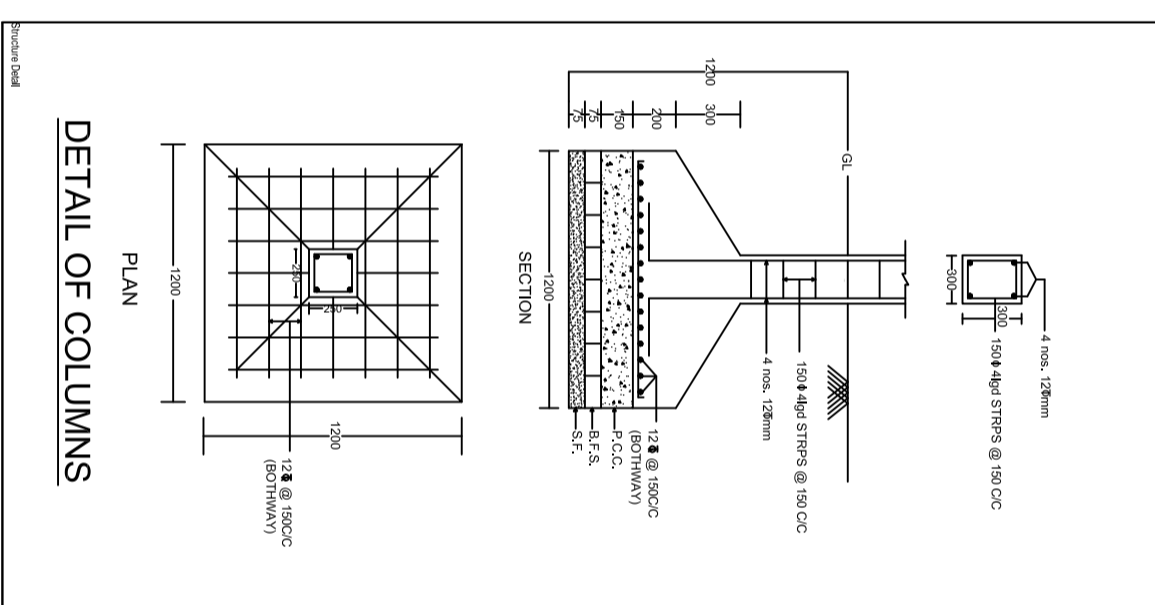
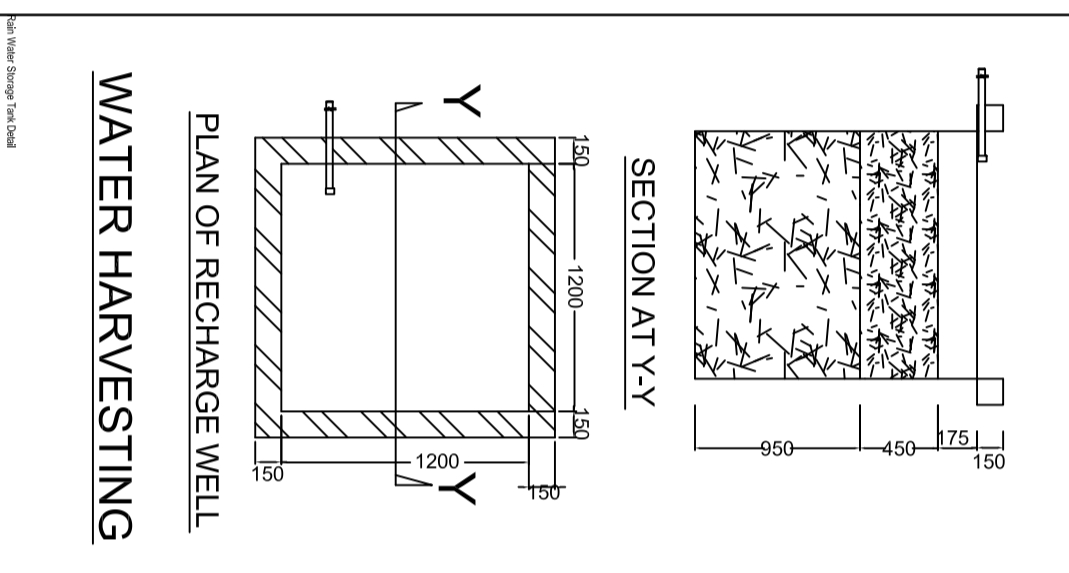
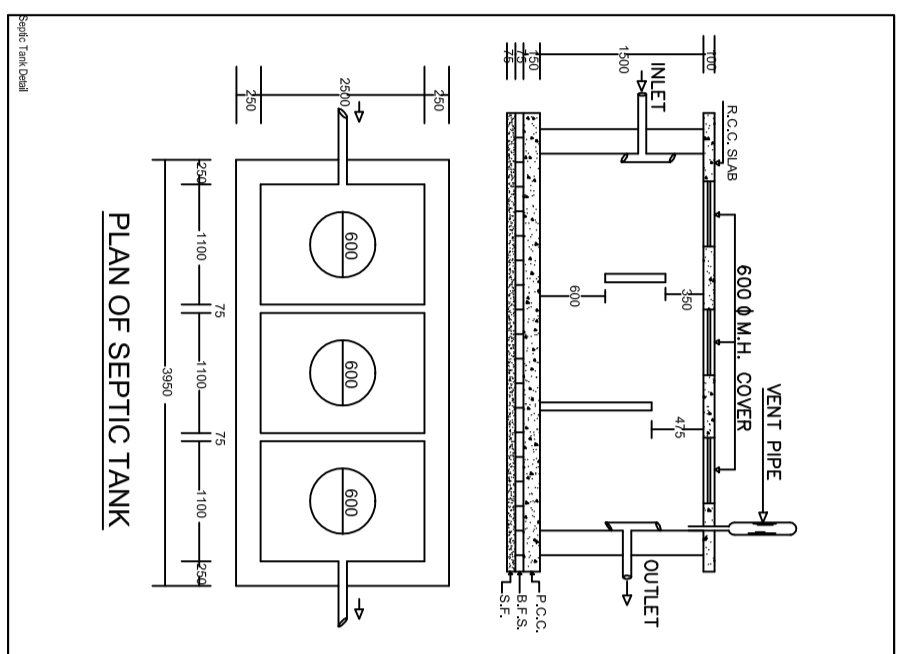
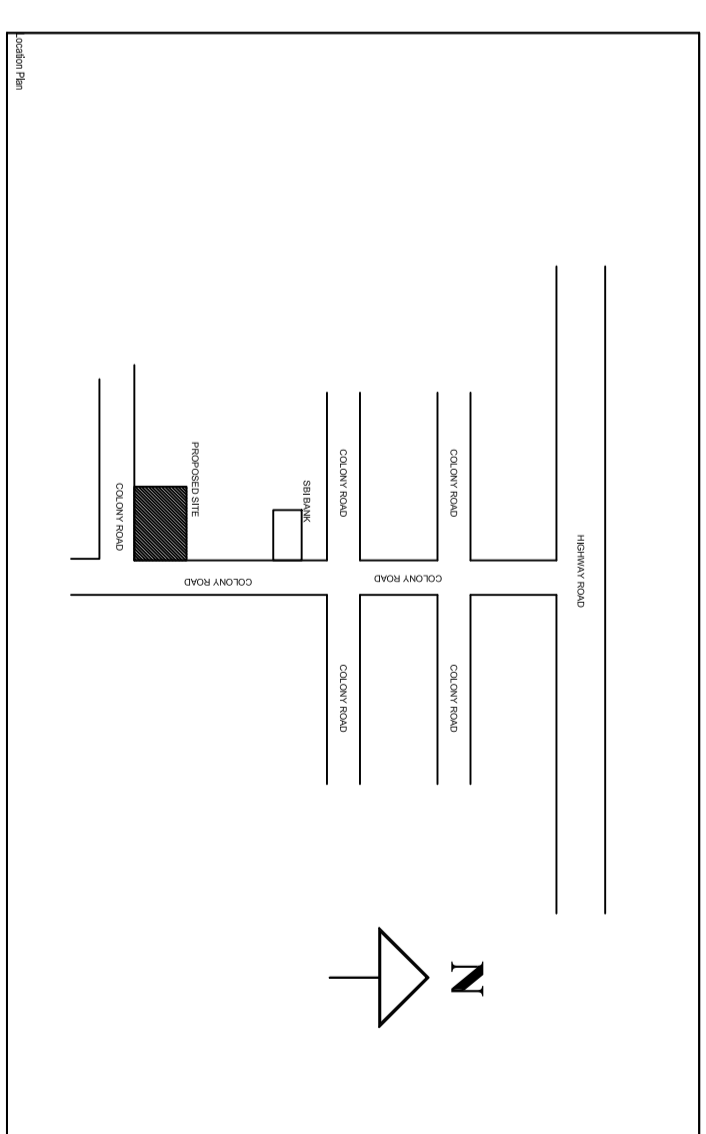
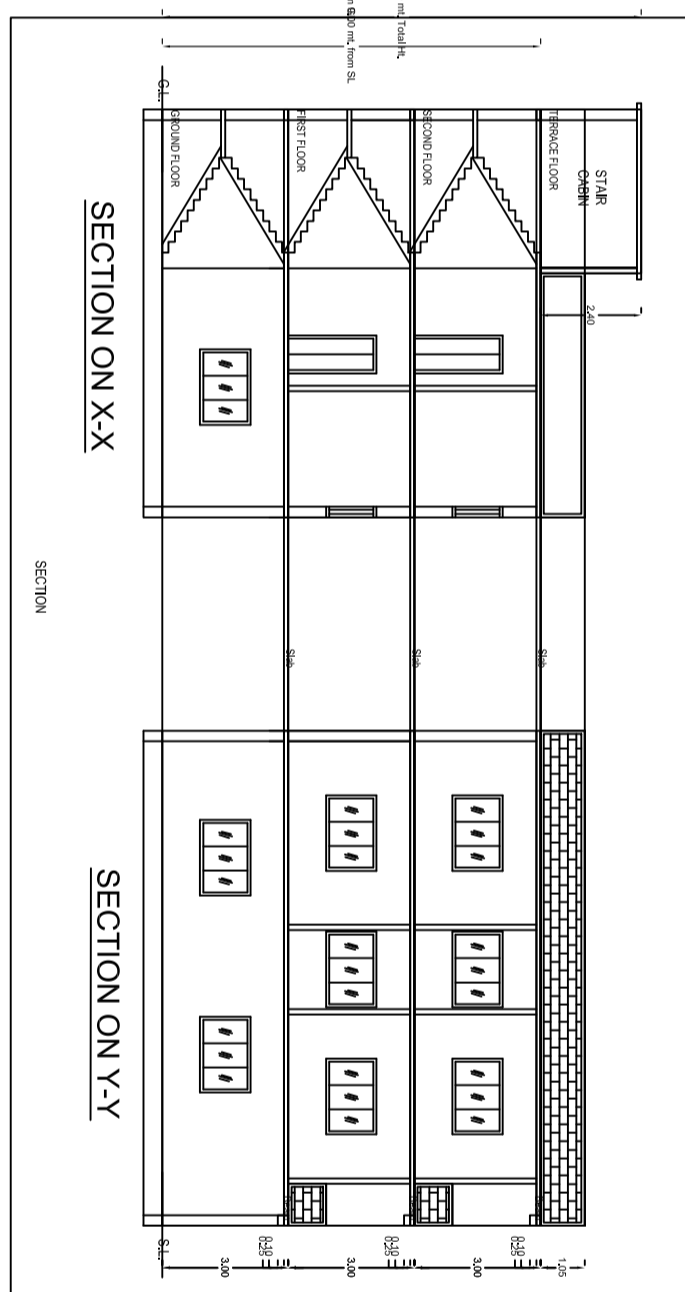
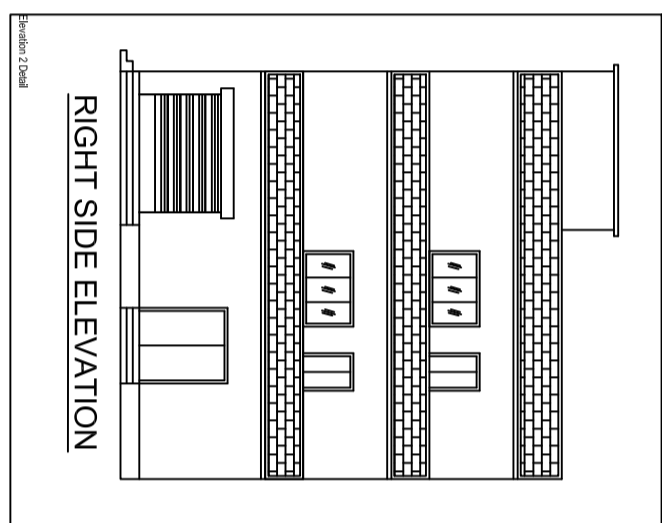
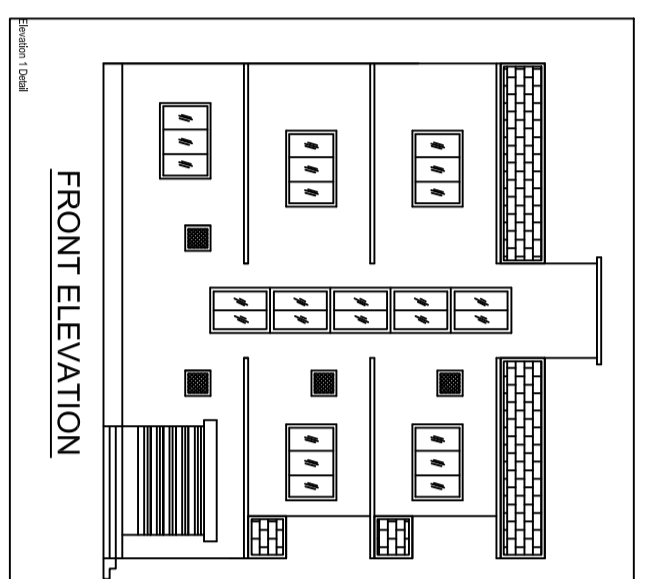

**BRIEF SPECIFICATION**

FOUNDATION----- CEMENT CONCRETE (1:1.5:3)  
BRICK WORK IN FOUNDATION & SUPERSTRUCTURE  
FIRST CLASS BRICK WORK IN CEMENT MORTAR (1:6)  
D.P.C----- 25 D.P.C. IN CEMENT CONCRETE (1:2:4)  
FLOOR----- 25 L.P.S. OVER 75 P.C.C.  
ROOF----- 100 THK. R.C.C. ROOF (1:1.5:3)  
LINTEL----- 50 THK. R.C.C. LINTEL (1:1.5:3)  
STAIRS----- RISE- 150, TREAD- 250

**DETAILS OF AREA**

TOTAL AREA (AS PER DEED)----- 323.86 SQM.  
TOTAL AREA (AS PER SITE)----- 321.98 SQM.  
GROUND FLOOR AREA----- 114.18 SQM.  
FIRST FLOOR AREA----- 114.18 SQM.  
SECOND FLOOR AREA----- 114.18 SQM.  
TOTAL COVERED AREA----- 342.48 SQM.  
% PLOT AREA----- 35.45 %  
FAR----- 1.08

**SCHEDULE**

D = 1.200X2.100      W = 1.800X1.200  
D1 = 1.050X2.100      W2 = 0.900X1.200  
D2 = 0.900X2.100      V = 0.600X0.600

**TITLE OF DRAWING**

PLAN OF PROPOSED RESIDENTIAL BUILDING OF SMT POONAM SINGH S/O SRI NAVIN KUMAR SINGH OF SECTOR 12/A, QTR. NO.-3145, B.S. CITY, DIST.-BOKARO, UNDER MOUZA - TETULUA, NO.- 38, KHATA NO.-59, NEW KHATA NO.- 158, PLOT NO.-450 NEW PLOT NO.-1287 IN THE DISTT. OF BOKARO (JHARKHAND).

SIGNATURE OF OWNER

SIGNATURE OF ENGINEER

SCALE ALL DIMENSION ARE IN METRE

Building Schedule

Sl. No.	Particulars	Quantity	Rate	Amount
1	CEMENT	1000	100	100000
2	BRICKS	2000	50	100000
3	ROOFING	1000	200	200000
4	WATER HARVESTING	1000	150	150000
5	SEPTIC TANK	1000	100	100000
6	CONCRETE	5000	200	1000000
7	LABOUR	10000	100	1000000
8	PROFIT	10000	100	1000000
9	TOTAL			6000000

Scale of Drawing

Scale	Horizontal	Vertical
1:100	1cm = 1m	1cm = 1m
1:200	1cm = 2m	1cm = 2m
1:500	1cm = 5m	1cm = 5m
1:1000	1cm = 10m	1cm = 10m

Uttarakhand State Building Schedule

Sl. No.	Particulars	Quantity	Rate	Amount
1	CEMENT	1000	100	100000
2	BRICKS	2000	50	100000
3	ROOFING	1000	200	200000
4	WATER HARVESTING	1000	150	150000
5	SEPTIC TANK	1000	100	100000
6	CONCRETE	5000	200	1000000
7	LABOUR	10000	100	1000000
8	PROFIT	10000	100	1000000
9	TOTAL			6000000

Sl. No.	Particulars	Quantity	Rate	Amount
1	CEMENT	1000	100	100000
2	BRICKS	2000	50	100000
3	ROOFING	1000	200	200000
4	WATER HARVESTING	1000	150	150000
5	SEPTIC TANK	1000	100	100000
6	CONCRETE	5000	200	1000000
7	LABOUR	10000	100	1000000
8	PROFIT	10000	100	1000000
9	TOTAL			6000000