

SITE PLAN
SCALE - 1" = 16'-0" SITE PLAN

FAR & Tenement Details (Table 4c-1)

Building	No. of Same Bldg	Total Built Up Area (Sq.mt.)	Proposed FAR Area (Sq.mt.)	Total FAR Area (Sq.mt.)	Total Consumed Additional FAR Area (Sq.mt.)	Tnmt (No.)
A (SANDHA)	1	178.52	178.52	178.52	178.52	01
Grand Total:	1	178.52	178.52	178.52	178.52	01

Proposal Basic Information

Proposal File No.	MADA/BP/0090/2023
Owner Name	SMT. SANDHA OJHA
Khata No	OLD KHATA NO-257, NEW KHATA NO-41
Plot No	OLD PLOT NO-2306, NEW PLOT NO-1146
Village Name	Aamtal
Use	Residential
SubUse	Bungalow/ Dwelling / Non Apartment

AREA STATEMENT MINERAL AREA DEVELOPMENT AUTHORITY	VERSION NO.: 1.0.66 VERSION DATE: 16/10/2020
PROJECT DETAIL:	
Region: JHARKHAND URBAN LOCAL BODIES	Plot Use: Residential
District: DHANBAD	Plot SubUse: Bungalow/ Dwelling / Non Apartment
Authority: MINERAL AREA DEVELOPMENT AUTHORITY	PlotNearbyReligiousStructure: NA
Inward No: MADA/BP/0090/2023	PlotSubPlot No: OLD PLOT NO-2306, NEW PLOT NO-1146
Application Type: General Proposal	North: Plot No. - SAME PLOT
Project Type: Building Permission	South: Plot No. - SAME PLOT
Nature of Development: New	East: Plot No. - SAME PLOT
Location of Development Area: Old Area	West: Road Width - 6.10
AREA DETAILS:	
AREA OF PLOT (Minimum)	(A) 146.14
NET AREA OF PLOT(Gross Plot Area - Deduction from Gross Plot area)	(A-Deductions) 146.14
Deduction for Balance Plot Area(from Gross Plot Area)	
Common Plot	14.80
Total	14.80
BALANCE AREA OF PLOT(Net Plot Area - Recreational/Amenity space)	(A-Deductions) 131.34
PLOT AREA FOR COVERAGE(Net Plot Area)	(A-Deductions) 146.14
Plot Area for FAR (Net Plot Area + RoadWidening Area)	(A-Deductions) 146.14
COVERAGE CHECK	
Permissible Coverage area (70.00 %)	102.30
Proposed Coverage Area (61.08 %)	89.26
Total Prop. Coverage Area (61.08 %)	89.26
Balance coverage area (8.92 %)	13.04
FAR CHECK	
Perm. FAR Area (2.500)	365.35
Total Perm. FAR area	365.35
Residential FAR	178.51
Proposed FAR Area	178.51
Total Proposed FAR Area	178.51
Consumed FAR (Factor)	1.22
Balance FAR Area	186.84
BUILT UP AREA CHECK	
Total Proposed BuiltUp Area	178.52
ARCHITECT (Regd)	RAM PRATAP SINGH
ENGINEER (Regd)	
SUPERVISOR (Regd)	
OWNER (Regd)	SMT. SANDHA OJHA
DEVELOPMENT AUTHORITY	LOCAL BODY

COLOR INDEX	
PLOT BOUNDARY	Black
ABUTTING ROAD	Green
PROPOSED CONSTRUCTION	Red
COMMON PLOT	Yellow
ROAD WIDENING AREA	Blue
EXISTING (To be retained)	Blue
EXISTING (To be demolished)	Yellow

Buildingwise Floor FAR Details

Floor Name	Building Name A (SANDHA)		Total	
	Proposed Built Up Area (Sq.mt.)	Proposed FAR Area (Sq.mt.)	Total Proposed Built Up Area (Sq.mt.)	Total FAR Area (Sq.mt.)
Ground Floor	89.26	89.26	89.26	89.26
First Floor	89.26	89.26	89.26	89.26
Terrace Floor	0.00	0.00	0.00	0.00
Total :	178.52	178.52	178.52	178.52

Building USE/SUBUSE Details

Building Name	Building Use	Building SubUse	Building Structure
A (SANDHA)	Residential	Bungalow/ Dwelling / Non Apartment	Non-Highrise

LTP NAME AND SIGNATURE	STRUCTURAL ENG'S NAME AND SIGNATURE	BUILDER NAME AND SIGNATURE	DIGITAL SIGNATURE
RAM PRATAP SINGH MADA/ARC/0024/2019			

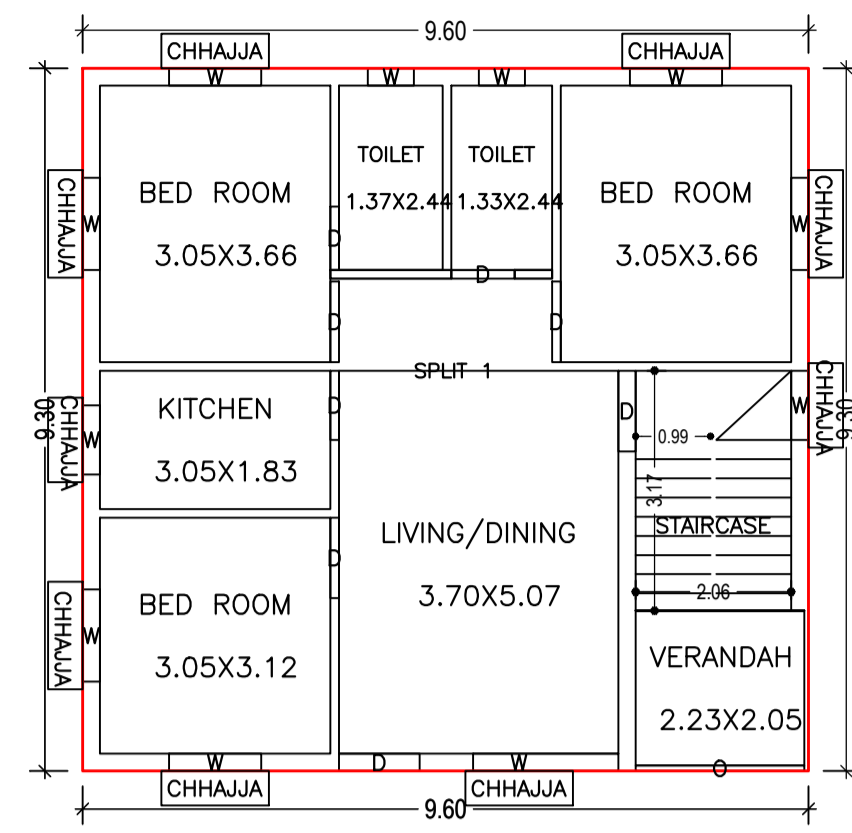

GROUND FLOOR PLAN (Proposed) (SCALE 1:100)

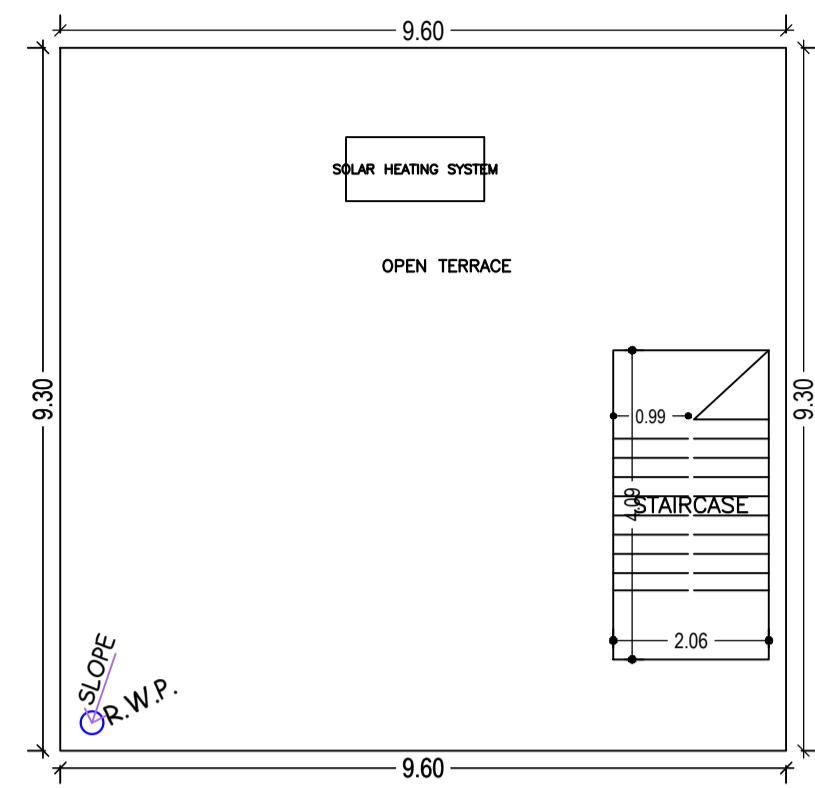

TERRACE FLOOR PLAN (SCALE 1:100)

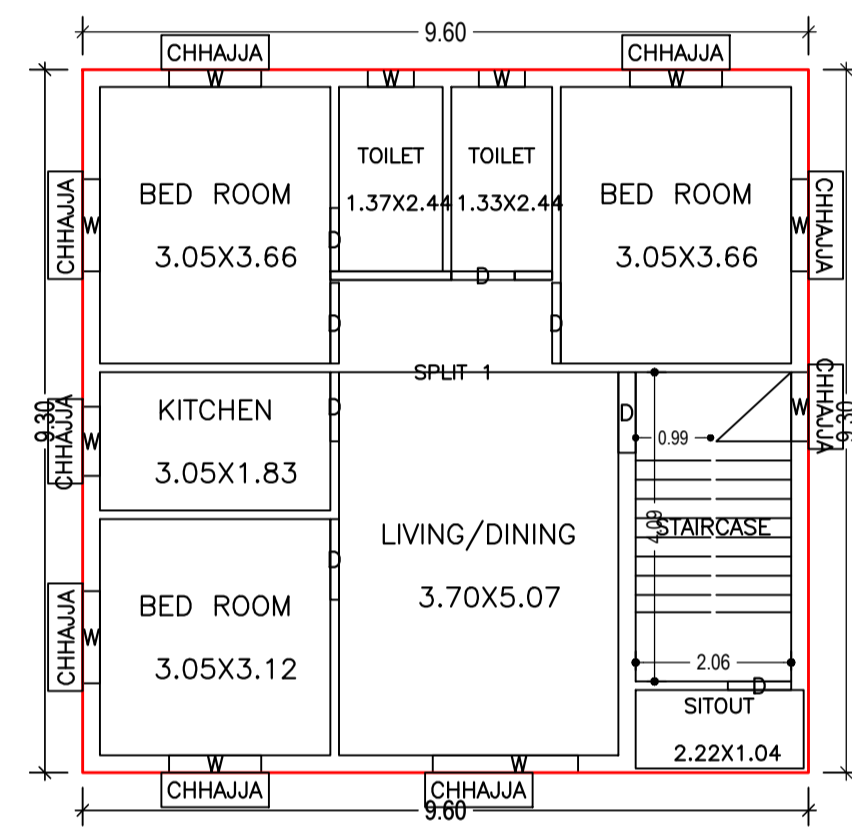

FIRST FLOOR PLAN (Proposed) (SCALE 1:100)

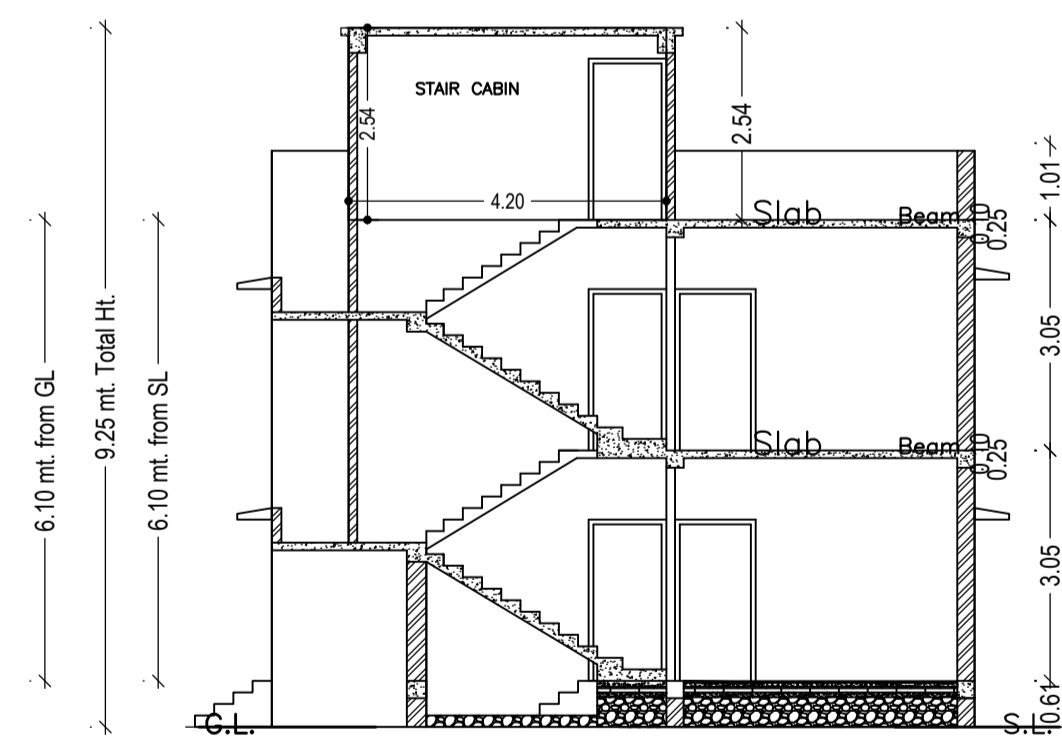

SECTION - XX' (SCALE - 1" = 8'-0")

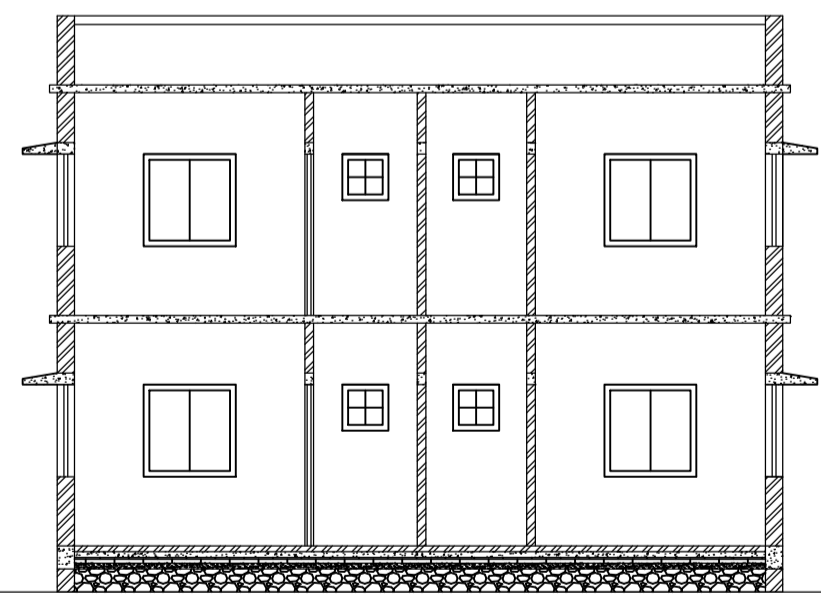

SECTION - YY' (SCALE - 1" = 8'-0")

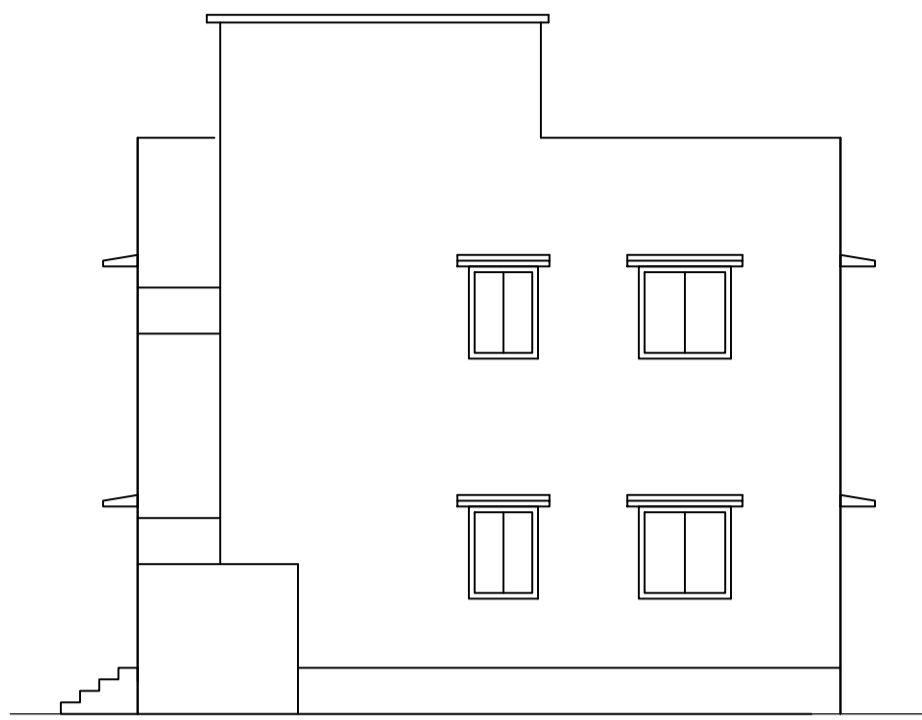

RIGHT SIDE ELEVATION (SCALE - 1" = 8'-0")

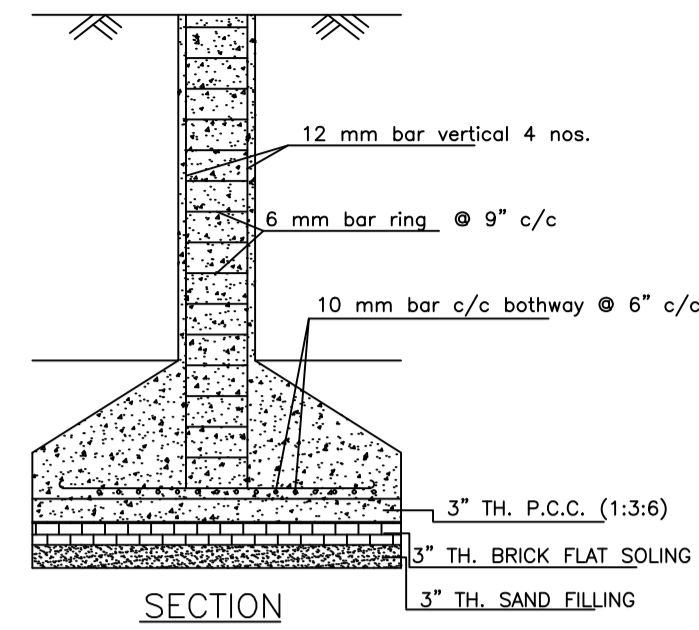

DETAILS OF COLUMN FOUNDATION (SCALE - 1" = 2'-0")

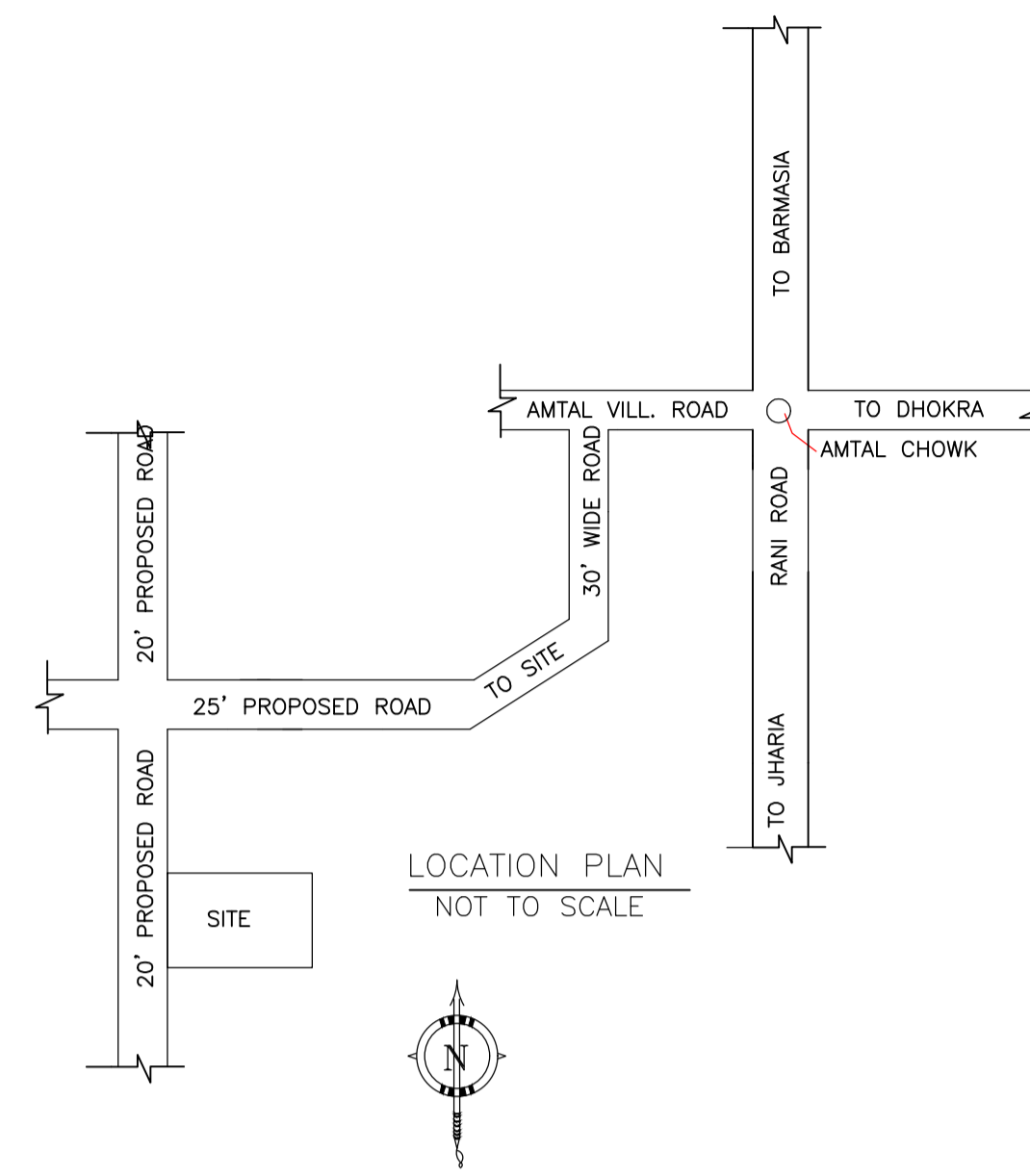

LOCATION PLAN (NOT TO SCALE)

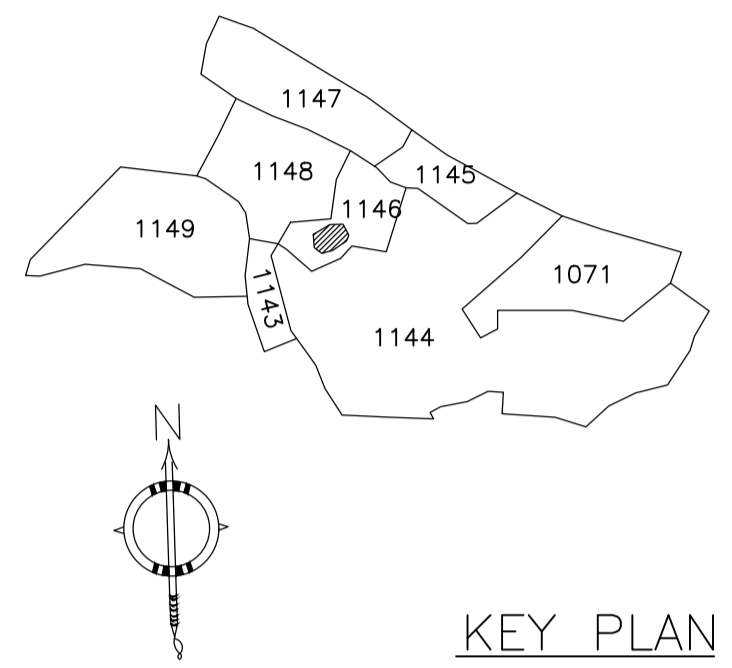

KEY PLAN

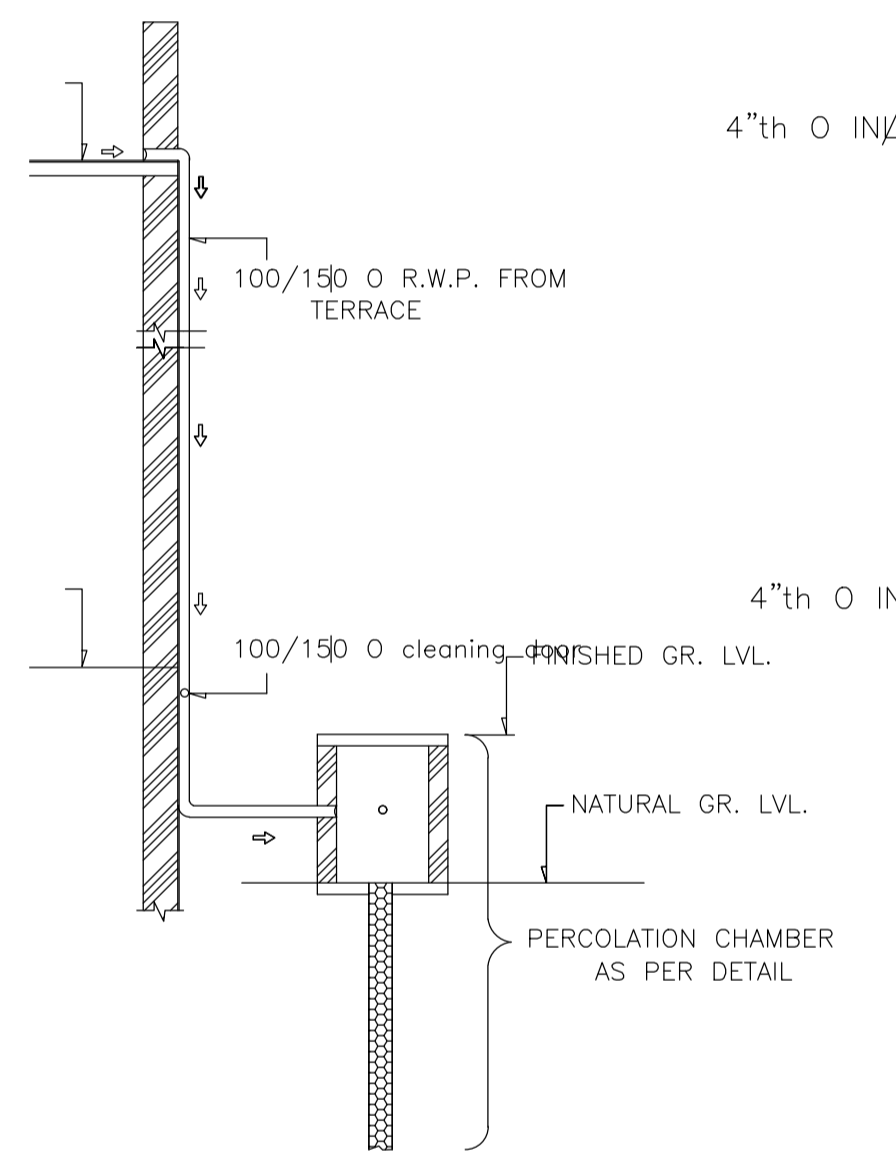

ROOF TOP RAIN WATER COLLECTION SYSTEM (SCALE = 1" = 4'-0")

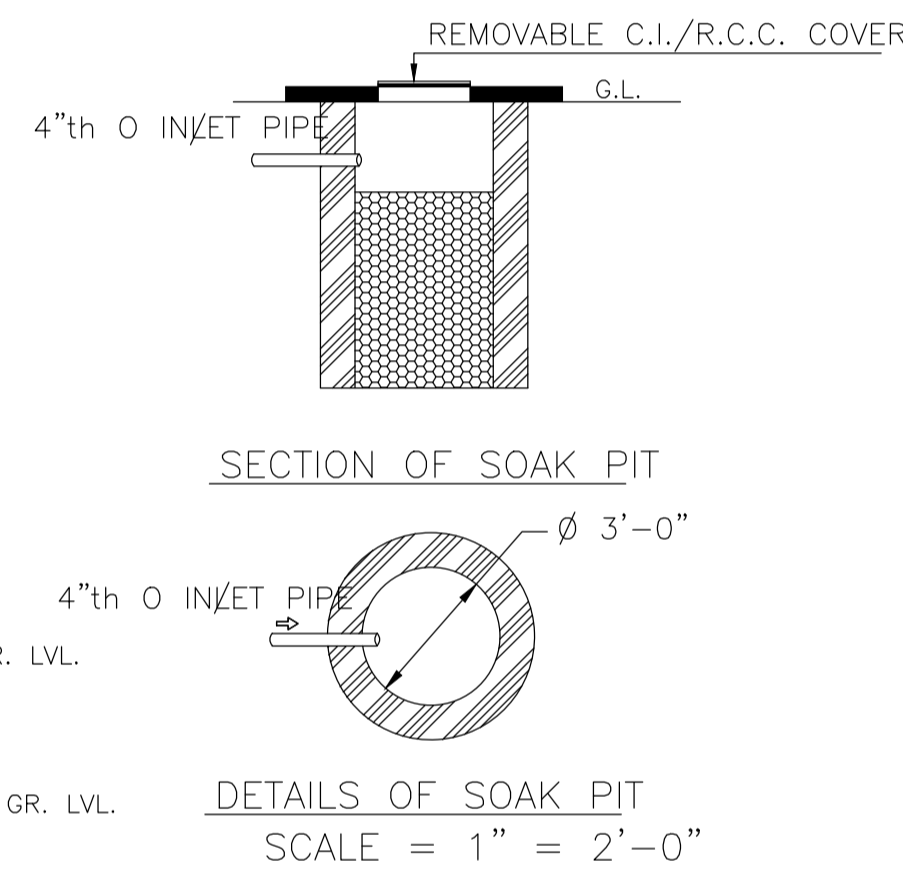

SECTION OF SOAK PIT (SCALE = 1" = 2'-0")

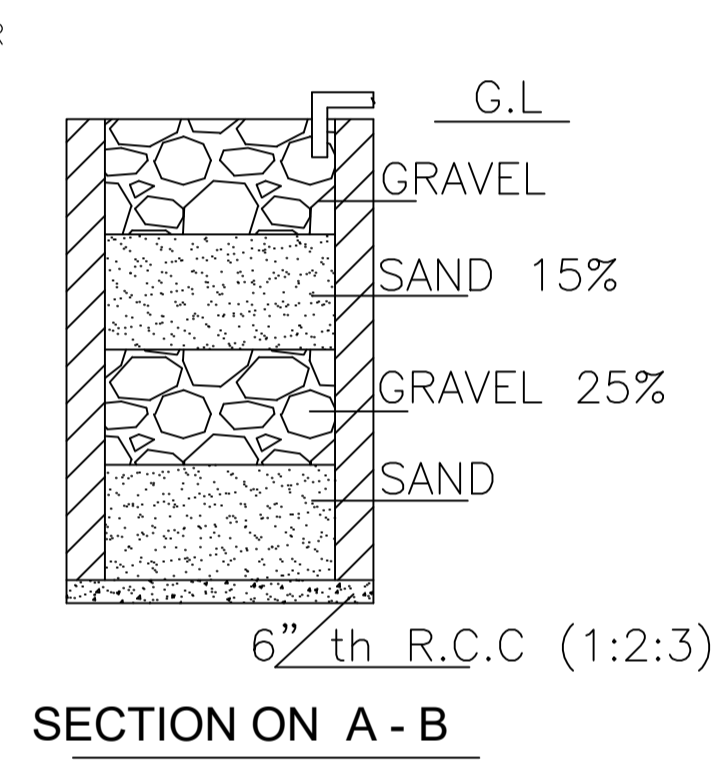

SECTION ON A - B (SCALE:- 1"=2'-0")

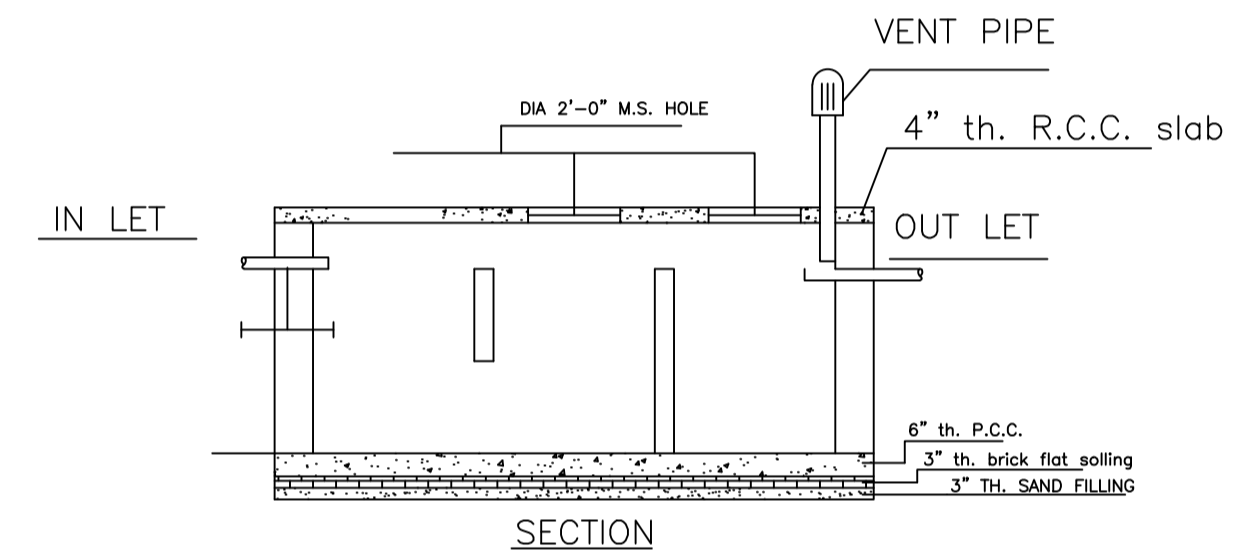

DETAILS OF SEPTIC TANK (SCALE - 1" = 4'-0")



FRONT ELEVATION (SCALE - 1" = 8'-0")

Building :A (SANDHA)

Floor Name	Total Built Up Area (Sq.mt.)	Proposed FAR Area (Sq.mt.) Resi.	Total FAR Area (Sq.mt.)	Total Consumed Additional FAR Area (Sq.mt.)	Tnmt (No.)
Ground Floor	89.26	89.26	89.26	89.26	01
First Floor	89.26	89.26	89.26	89.26	00
Terrace Floor	0.00	0.00	0.00	0.00	00
Total:	178.52	178.52	178.52	178.52	01
Total Number of Same Buildings	1				
Total:	178.52	178.52	178.52	178.52	01

SCHEDULE OF DOOR:

BUILDING NAME	NAME	LENGTH	HEIGHT	NOS
A (SANDHA)	D	0.84	2.10	05
A (SANDHA)	D	0.91	2.10	02
A (SANDHA)	D	1.07	2.10	09
A (SANDHA)	O	2.23	2.10	01

SCHEDULE OF WINDOW/VENTILATION:

BUILDING NAME	NAME	LENGTH	HEIGHT	NOS
A (SANDHA)	W	0.61	1.20	04
A (SANDHA)	W	0.91	1.20	04
A (SANDHA)	W	1.22	1.20	12
A (SANDHA)	W	1.92	1.20	02

UnitBUA Table for Building :A (SANDHA)

FLOOR	Name	UnitBUA Type	UnitBUA Area	Carpet Area	No. of Rooms	No. of Tenement
GROUND FLOOR PLAN	SPLIT 1	FLAT	178.51	178.03	8	1
FIRST FLOOR PLAN	SPLIT 1	FLAT	0.00	0.00	8	0
Total:	-	-	178.51	178.03	16	1

LTP NAME AND SIGNATURE	STRUCTURAL ENG'S NAME AND SIGNATURE	BUILDER NAME AND SIGNATURE	DIGITAL SIGNATURE
RAM PRATAP SINGH MADA/ARC/0024/2019			