

SITE PLAN  
SCALE - 1" = 8'-0"

GROUND FLOOR PLAN  
(Proposed)  
(SCALE 1:100)

UnitBUA Table for Building :A (ANAND PRAKASH PASWAN AND SHALINI KUMARI)

FLOOR	Name	UnitBUA Type	UnitBUA Area (Sq.mt.)	Carpet Area (Sq.mt.)	No. of Rooms	No. of Tenement
GROUND FLOOR PLAN	SPLIT A	FLAT	244.92	244.71	6	1
FIRST FLOOR PLAN	SPLIT A	FLAT	0.00	0.00	7	0
SECOND FLOOR PLAN	SPLIT A	FLAT	0.00	0.00	7	0
Total:	-	-	244.92	244.71	20	1

Building :A (ANAND PRAKASH PASWAN AND SHALINI KUMARI)

Floor Name	Total Built Up Area (Sq.mt.)	Proposed FAR Area (Sq.mt.)	Total FAR Area (Sq.mt.)	Total Consumed Additional FAR Area (Sq.mt.)	Tnmt (No.)
Ground Floor	81.64	81.64	81.64	81.64	01
First Floor	81.64	81.64	81.64	81.64	00
Second Floor	81.64	81.64	81.64	81.64	00
Terrace Floor	0.00	0.00	0.00	0.00	00
Total	244.92	244.92	244.92	244.92	01
Total Number of Same Buildings	1				
Total	244.92	244.92	244.92	244.92	01

SCHEDULE OF DOOR:

BUILDING NAME	NAME	LENGTH	HEIGHT	NOS
A (ANAND PRAKASH PASWAN AND SHALINI KUMARI)	D	0.76	2.10	03
A (ANAND PRAKASH PASWAN AND SHALINI KUMARI)	D	0.91	2.10	11
A (ANAND PRAKASH PASWAN AND SHALINI KUMARI)	D	0.99	2.10	03
A (ANAND PRAKASH PASWAN AND SHALINI KUMARI)	D	1.03	2.10	03
A (ANAND PRAKASH PASWAN AND SHALINI KUMARI)	D	1.22	2.10	01

SCHEDULE OF WINDOW/VENTILATION:

BUILDING NAME	NAME	LENGTH	HEIGHT	NOS
A (ANAND PRAKASH PASWAN AND SHALINI KUMARI)	V	0.61	1.20	03
A (ANAND PRAKASH PASWAN AND SHALINI KUMARI)	W	0.91	1.20	06
A (ANAND PRAKASH PASWAN AND SHALINI KUMARI)	W	1.22	1.20	18
A (ANAND PRAKASH PASWAN AND SHALINI KUMARI)	W	1.82	1.20	03

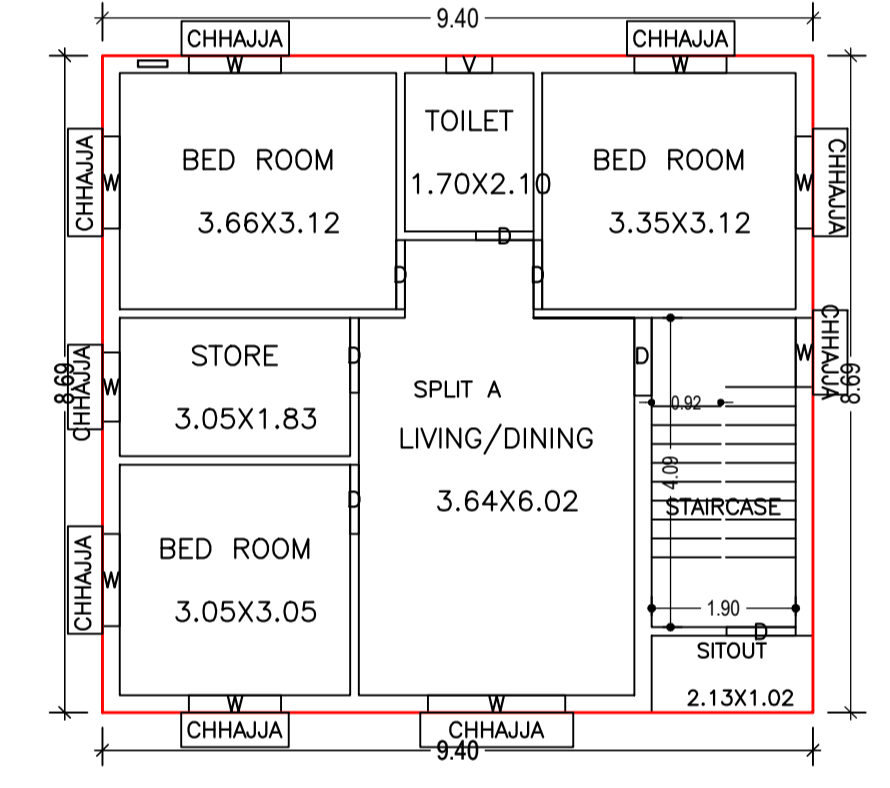
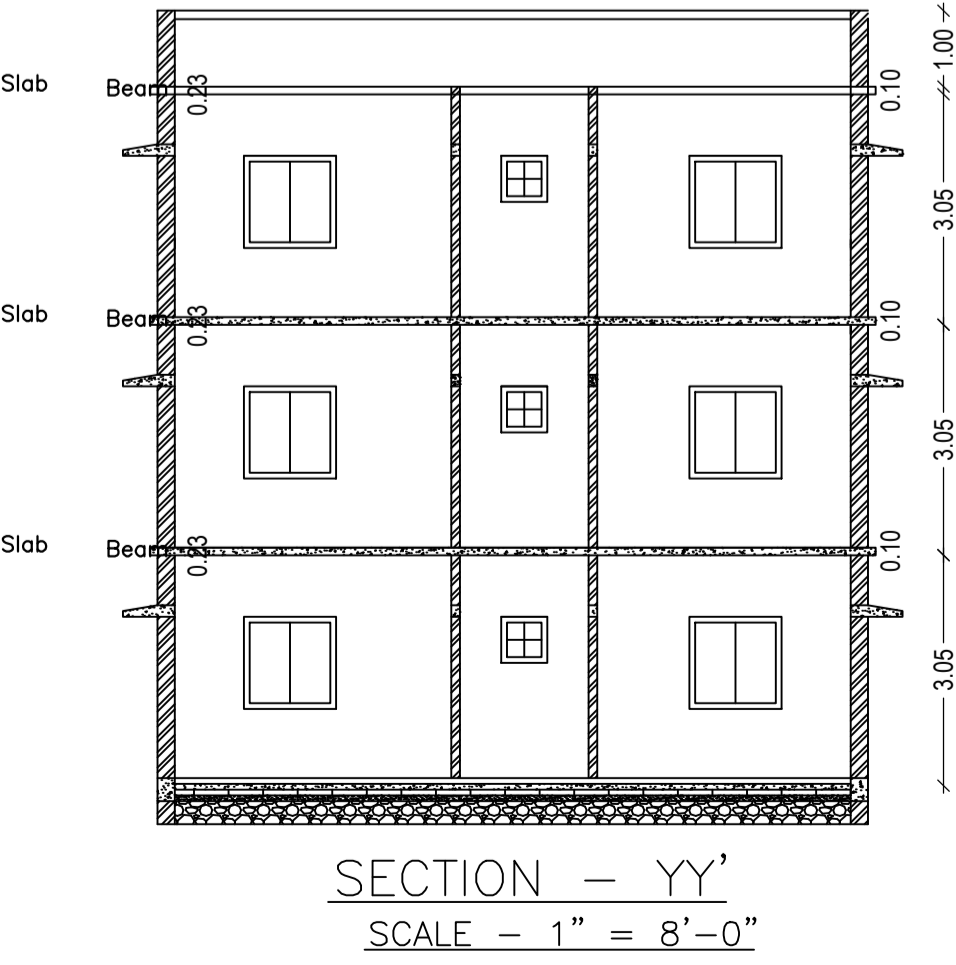
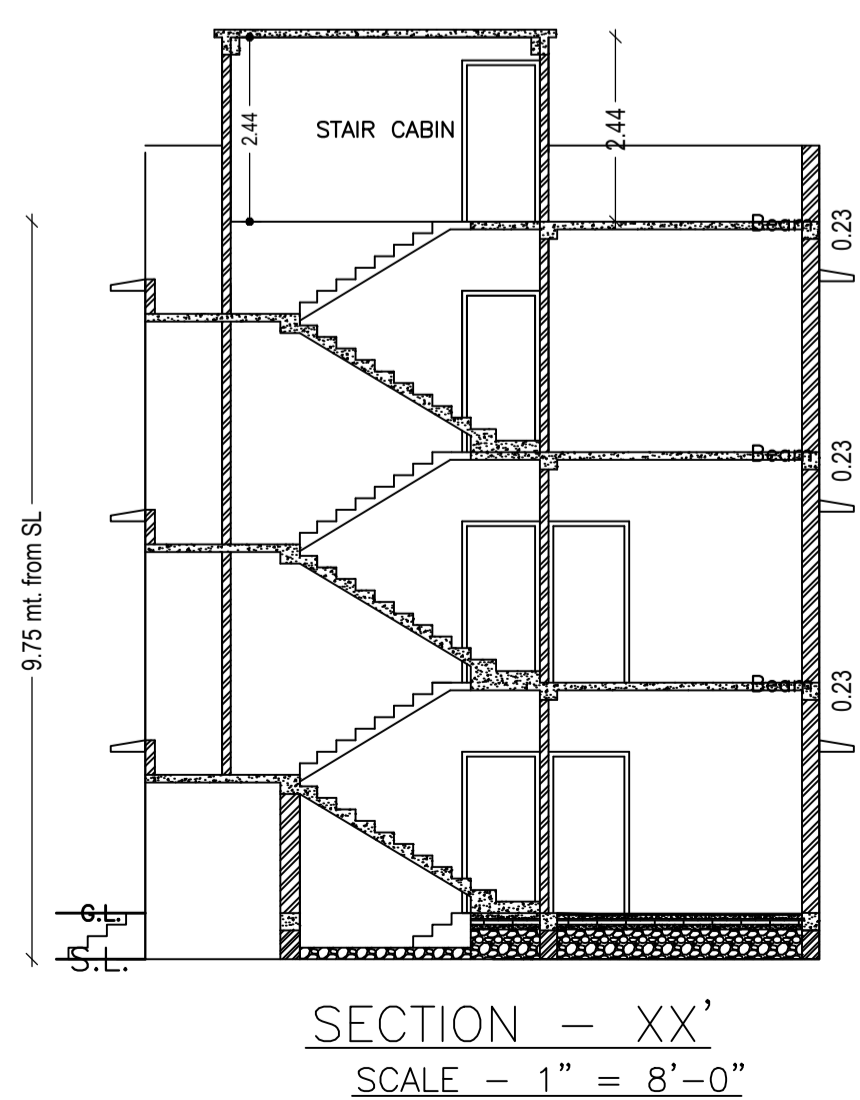
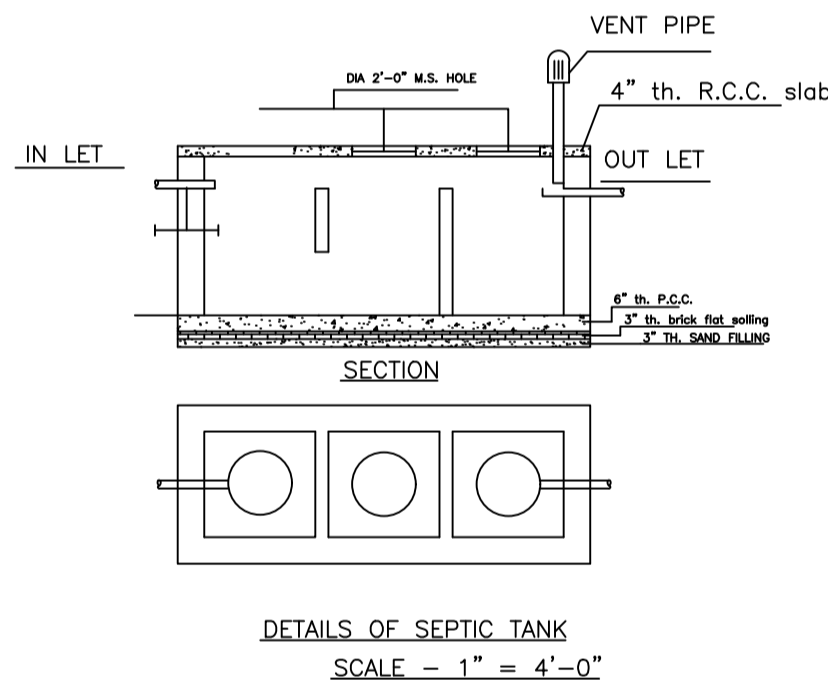
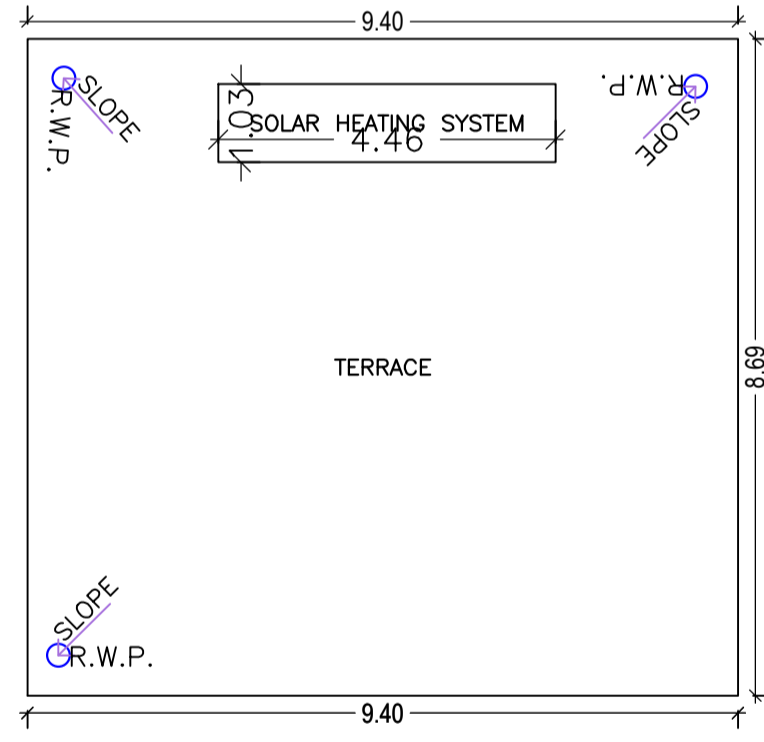
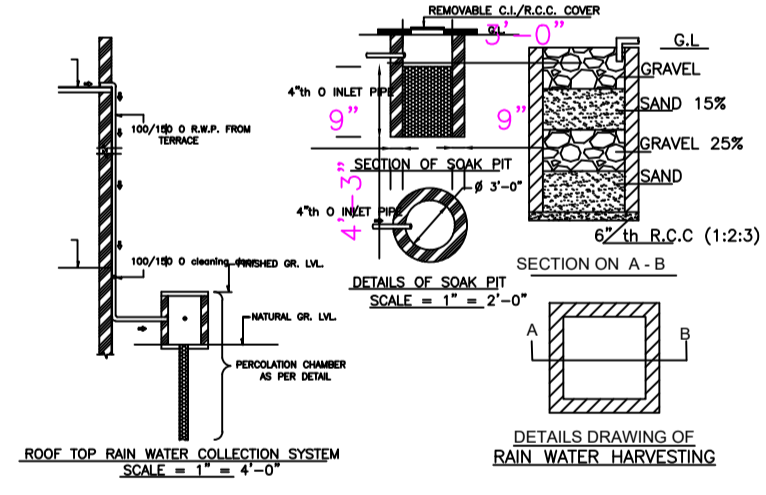

FIRST FLOOR PLAN  
(Proposed)  
(SCALE 1:100)

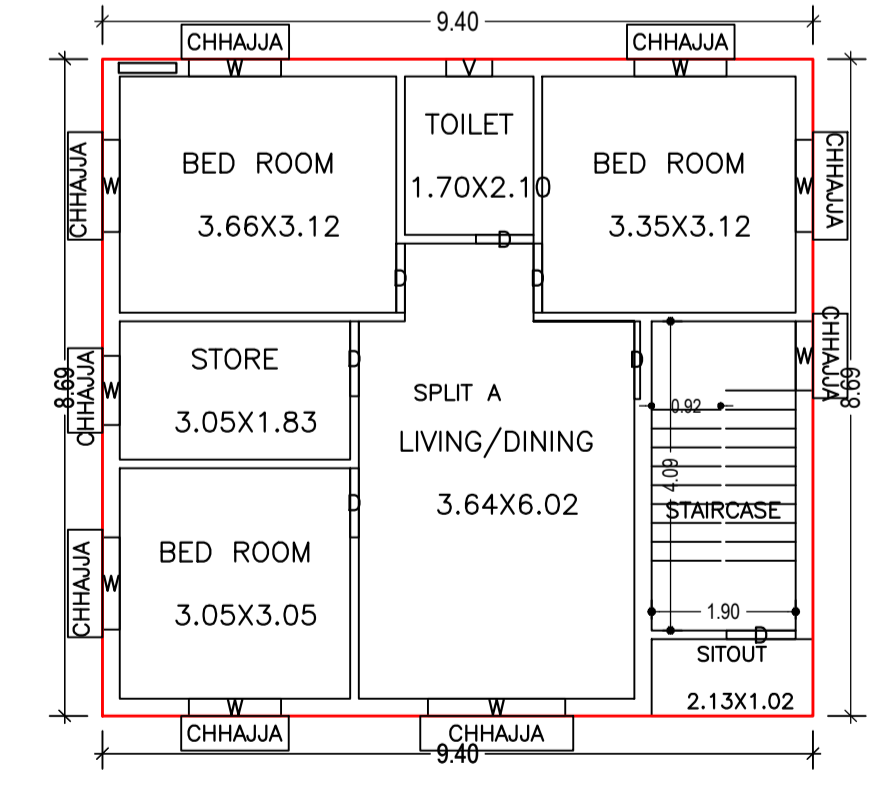

SECOND FLOOR PLAN  
(Proposed)  
(SCALE 1:100)

Proposal Basic Information

Proposal File No.	MADA/BP/0088/2023
Owner Name	1. SRI ANAND PRAKASH PASWAN AND 2. SMT. SHALINI KUMARI
Khata No.	OLD KHATA NO-53, NEW KHATA NO-82
Plot No.	OLD PLOT NO-2517, NEW PLOT NO-4053
Village Name	Bara Pichari
Use	Residential
SubUse	Bungalow/ Dwelling / Non Apartment

AREA STATEMENT MINERAL AREA DEVELOPMENT AUTHORITY

AREA DETAILS:	AREA	SQ.MT.
AREA OF PLOT (Minimum)	(A)	139.11
NET AREA OF PLOT(Gross Plot Area - Deduction from Gross Plot area)	(A-Deductions)	139.11
Deduction for Balance Plot Area(from Gross Plot Area)		
Common Plot		17.50
Total		17.50
BALANCE AREA OF PLOT(Net Plot Area - Recreational/Amenity space)	(A-Deductions)	121.61
PLOT AREA FOR COVERAGE(Net Plot Area)	(A-Deductions)	139.11
Plot Area for FAR (Net Plot Area + Road Widening Area)	(A-Deductions)	139.11
COVERAGE CHECK		
Permissible Coverage area ( 70.00 % )		97.38
Proposed Coverage Area ( 58.69 % )		81.64
Total Prop. Coverage Area ( 58.69 % )		81.64
Balance coverage area ( 11.31 % )		15.74
FAR CHECK		
Perm. FAR Area ( 2.500 )		347.77
Total Perm. FAR area		347.77
Residential FAR Area		244.92
Proposed FAR Area		244.92
Total Proposed FAR Area		244.92
Consumed FAR (Factor)		1.76
Balance FAR Area		102.85
BUILT UP AREA CHECK		
Total Proposed BuiltUp Area		244.92
ARCHITECT (Regd)		RAM PRATAP SINGH
ENGINEER (Regd)		
SUPERVISOR (Regd)		
OWNER (Regd)		1. SRI ANAND PRAKASH PASWAN AND 2. SMT. SHALINI KUMARI
DEVELOPMENT AUTHORITY		LOCAL BODY

COLOR INDEX

PLOT BOUNDARY	Black
ABUTTING ROAD	Red
PROPOSED CONSTRUCTION	Green
COMMON PLOT	Yellow
ROAD WIDENING AREA	Blue
EXISTING (To be retained)	Orange
EXISTING (To be demolished)	Purple

Buildingwise Floor FAR Details

Floor Name	Building Name A (ANAND PRAKASH PASWAN AND SHALINI KUMARI)		Total	
	Proposed Built Up Area (Sq.mt.)	Proposed FAR Area (Sq.mt.)	Total Proposed Built Up Area (Sq.mt.)	Total FAR Area (Sq.mt.)
Ground Floor	81.64	81.64	81.64	81.64
First Floor	81.64	81.64	81.64	81.64
Second Floor	81.64	81.64	81.64	81.64
Terrace Floor	0.00	0.00	0.00	0.00
Total :	244.92	244.92	244.92	244.92

Building USE/SUBUSE Details

Building Name	Building Use	Building SubUse	Building Structure
A (ANAND PRAKASH PASWAN AND SHALINI KUMARI)	Residential	Bungalow/ Dwelling / Non Apartment	Non-Highrise

FAR & Tenement Details (Table 4c-1)

Building	No. of Same Bldg	Total Built Up Area (Sq.mt.)	Proposed FAR Area (Sq.mt.)	Total FAR Area (Sq.mt.)	Total Consumed Additional FAR Area (Sq.mt.)	Tnmt (No.)
A (ANAND PRAKASH PASWAN AND SHALINI KUMARI)	1	244.92	244.92	244.92	244.92	01
Grand Total :	1	244.92	244.92	244.92	244.92	01

LTP NAME AND SIGNATURE	STRUCTURAL ENG'S NAME AND SIGNATURE	BUILDER NAME AND SIGNATURE	DIGITAL SIGNATURE
RAM PRATAP SINGH MADA/ARC/0024/2019			