

Building :RESI (USHA)

Floor Name	Total Built Up Area (Sq.mt.)	Proposed FAR Area (Sq.mt.) Resi.	Total FAR Area (Sq.mt.)	Total Consumed Additional FAR Area (Sq.mt.)	Tnmt (No.)
Ground Floor	61.76	61.76	61.76	61.76	01
First Floor	61.76	61.76	61.76	61.76	00
Terrace Floor	0.00	0.00	0.00	0.00	00
Total :	123.52	123.52	123.52	123.52	01
Total Number of Same Buildings	1				
Total :	123.52	123.52	123.52	123.52	01

Proposal Basic Information

Proposal File No.	MADA/BP/0086/2023
Owner Name	SMT. USHA DEVI
Khata No	OLD KHATA NO-50, NEW KHATA NO-178
Plot No	OLD PLOT NO-2536, NEW PLOT NO-3906
Village Name	Bara Pichari
Use	Residential
SubUse	Bungalow/ Dwelling / Non Apartment

AREA STATEMENT MINERAL AREA DEVELOPMENT AUTHORITY	VERSION NO. : 1.0.66 VERSION DATE: 16/10/2020	SQ.MT.
PROJECT DETAIL:		
Region: JHARKHAND URBAN LOCAL BODIES	Plot Use: Residential	
District: DHANBAD	Plot SubUse: Bungalow/ Dwelling / Non Apartment	
Authority: MINERAL AREA DEVELOPMENT AUTHORITY	PlotNearby/ReligiousStructure: NA	
Inward No: MADA/BP/0086/2023	Plot/SubPlot No: OLD PLOT NO-2536, NEW PLOT NO-3906	
Application Type: General Proposal	North: Plot No. - SAME PLOT	
Project Type: Building Permission	South: Plot No. - SAME PLOT	
Nature of Development: New	East: Road Width - 6.10	
Location of Development Area: Old Area	West: Plot No. - SAME PLOT	
AREA DETAILS:		
AREA OF PLOT (Minimum)	(A)	111.39
NET AREA OF PLOT(Gross Plot Area - Deduction from Gross Plot area)	(A-Deductions)	111.39
Deduction for Balance Plot Area(from Gross Plot Area)		
Common Plot		12.08
Total		12.08
BALANCE AREA OF PLOT(Net Plot Area - Recreational/Amenity space)	(A-Deductions)	99.30
PLOT AREA FOR COVERAGE(Net Plot Area)	(A-Deductions)	111.39
Plot Area for FAR (Net Plot Area + RoadWidening Area)	(A-Deductions)	111.39
COVERAGE CHECK		
Permissible Coverage area (70.00 %)		77.97
Proposed Coverage Area (55.45 %)		61.76
Total Prop. Coverage Area (55.45 %)		61.76
Balance coverage area (14.55 %)		16.21
FAR CHECK		
Perm. FAR Area (2.500)		278.48
Total Perm. FAR area		278.48
Residential FAR		123.52
Proposed FAR Area		123.52
Total Proposed FAR Area		123.52
Consumed FAR (Factor)		1.11
Balance FAR Area		154.96
BUILT UP AREA CHECK		
Total Proposed BuiltUp Area		123.52
ARCHITECT (Regd)	RAM PRATAP SINGH	
ENGINEER (Regd)		
SUPERVISOR (Regd)	SMT. USHA DEVI	
OWNER (Regd)		
DEVELOPMENT AUTHORITY		LOCAL BODY

COLOR INDEX

PLOT BOUNDARY	Black
ABUTTING ROAD	Green
PROPOSED CONSTRUCTION	Red
COMMON PLOT	Yellow
ROAD WIDENING AREA	Orange
EXISTING (To be retained)	Blue
EXISTING (To be demolished)	Light Blue

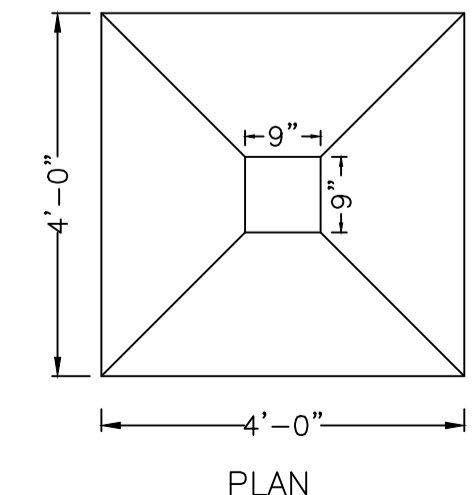
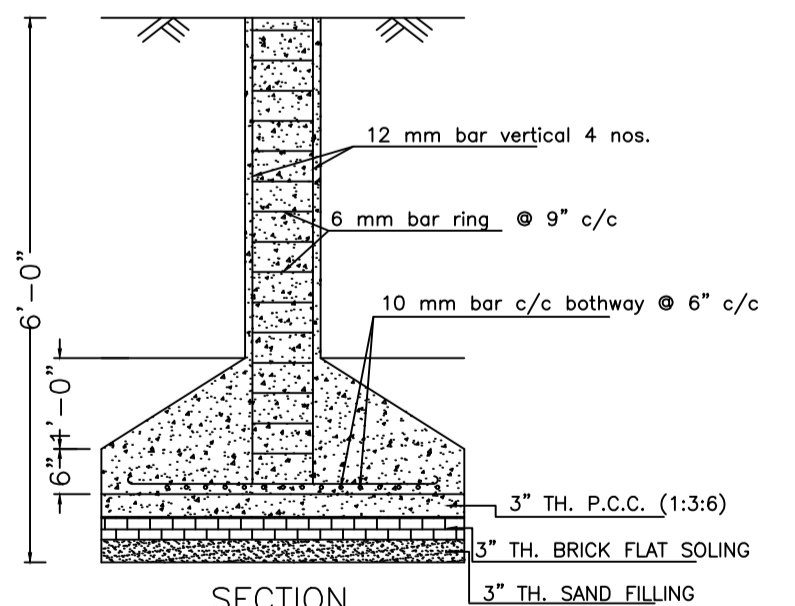
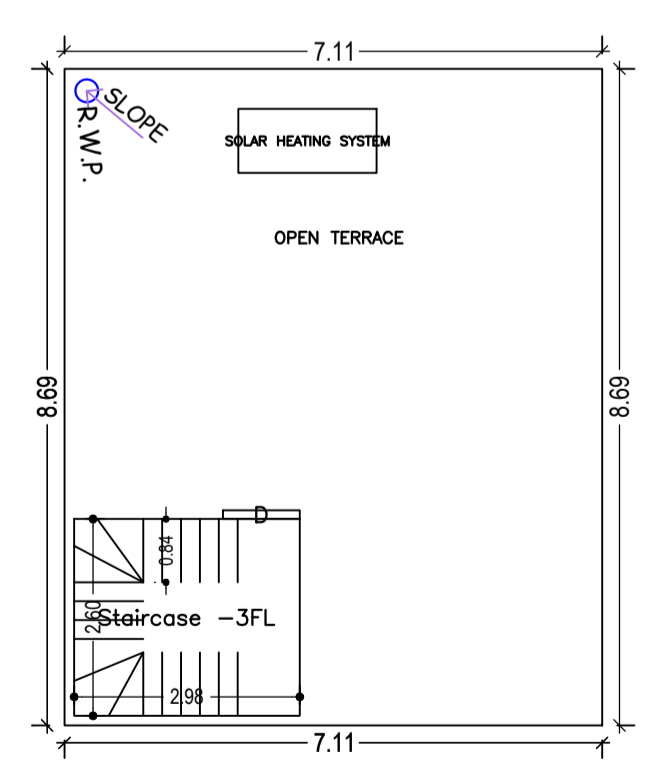
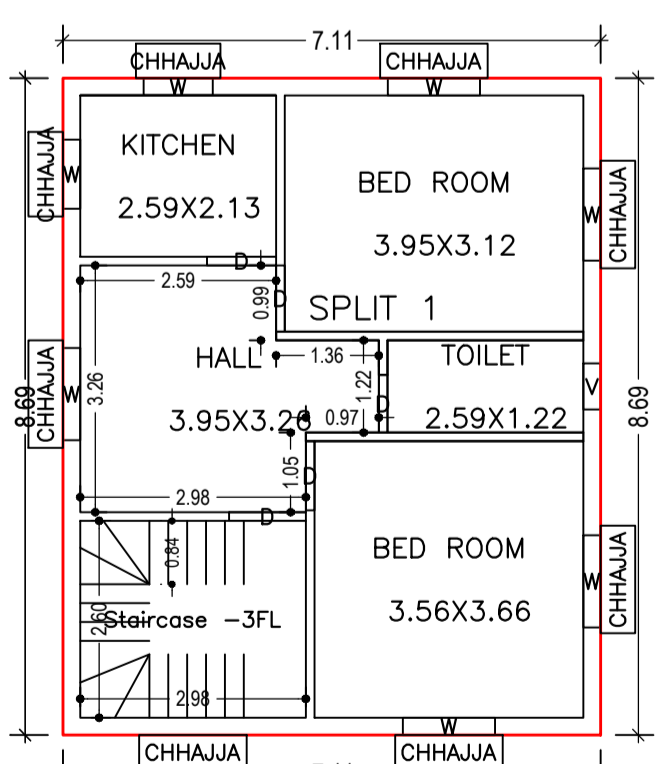
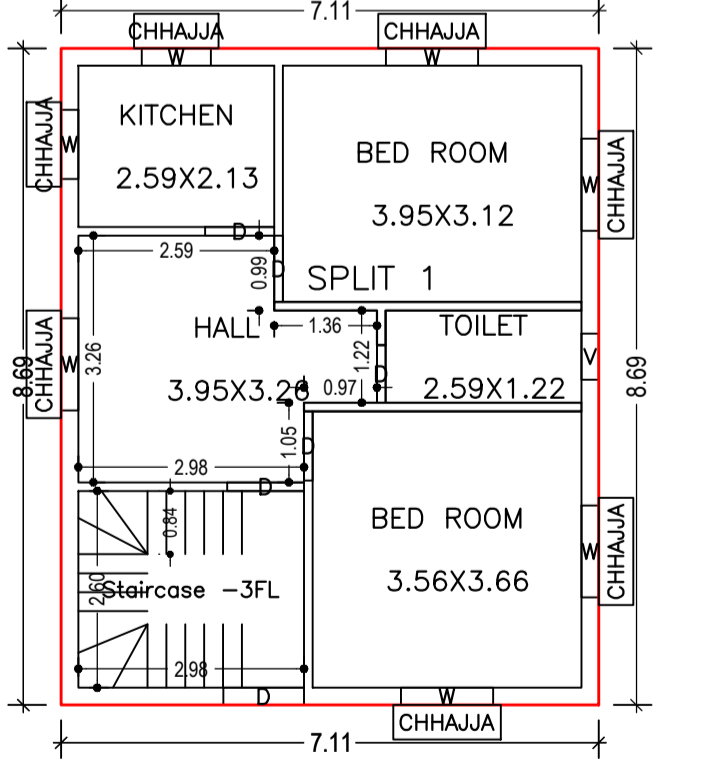

DETAILS OF COLUMN FOUNDATION

SCHEDULE OF DOOR:

BUILDING NAME	NAME	LENGTH	HEIGHT	NOS
RESI (USHA)	D	0.76	2.10	02
RESI (USHA)	D	0.88	2.10	02
RESI (USHA)	D	0.91	2.10	04
RESI (USHA)	D	1.02	2.10	02

SCHEDULE OF WINDOW/VENTILATION:

BUILDING NAME	NAME	LENGTH	HEIGHT	NOS
RESI (USHA)	V	0.61	1.20	02
RESI (USHA)	W	0.91	1.20	04
RESI (USHA)	W	1.22	1.20	10

UnitBUA Table for Building :RESI (USHA)

FLOOR	Name	UnitBUA Type	UnitBUA Area	Carpet Area	No. of Rooms	No. of Tenement
GROUND FLOOR PLAN	SPLIT 1	FLAT	123.52	121.65	5	1
FIRST FLOOR PLAN	SPLIT 1	FLAT	0.00	0.00	5	0
Total:			123.52	121.65	10	1

Buildingwise Floor FAR Details

Floor Name	Building Name		Total	
	Proposed Built Up Area (Sq.mt.)	Proposed FAR Area (Sq.mt.)	Total Proposed Built Up Area (Sq.mt.)	Total FAR Area (Sq.mt.)
Ground Floor	61.76	61.76	61.76	61.76
First Floor	61.76	61.76	61.76	61.76
Terrace Floor	0.00	0.00	0.00	0.00
Total :	123.52	123.52	123.52	123.52

Building USE/SUBUSE Details

Building Name	Building Use	Building SubUse	Building Structure
RESI (USHA)	Residential	Bungalow/ Dwelling / Non Apartment	Non-Highrise

FAR & Tenement Details (Table 4c-1)

Building	No. of Same Bldg	Total Built Up Area (Sq.mt.)	Proposed FAR Area (Sq.mt.) Resi.	Total FAR Area (Sq.mt.)	Total Consumed Additional FAR Area (Sq.mt.)	Tnmt (No.)
RESI (USHA)	1	123.52	123.52	123.52	123.52	01
Grand Total :	1	123.52	123.52	123.52	123.52	01

LTP NAME AND SIGNATURE	STRUCTURAL ENG'S NAME AND SIGNATURE	BUILDER NAME AND SIGNATURE	DIGITAL SIGNATURE
RAM PRATAP SINGH MADA/ARC/0024/2019			