

GROUND FLOOR PLAN (Proposed) (SCALE 1:100)

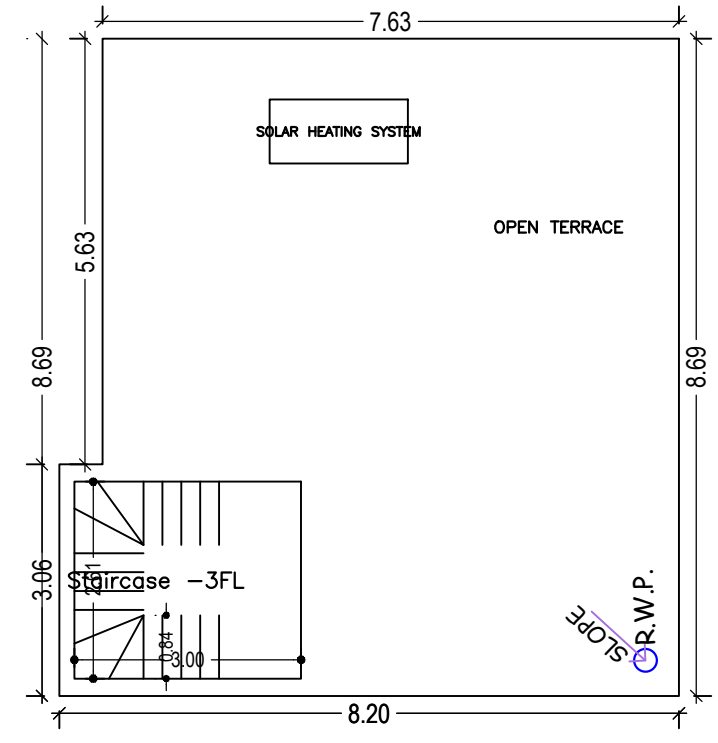

TERRACE FLOOR PLAN (SCALE 1:100)

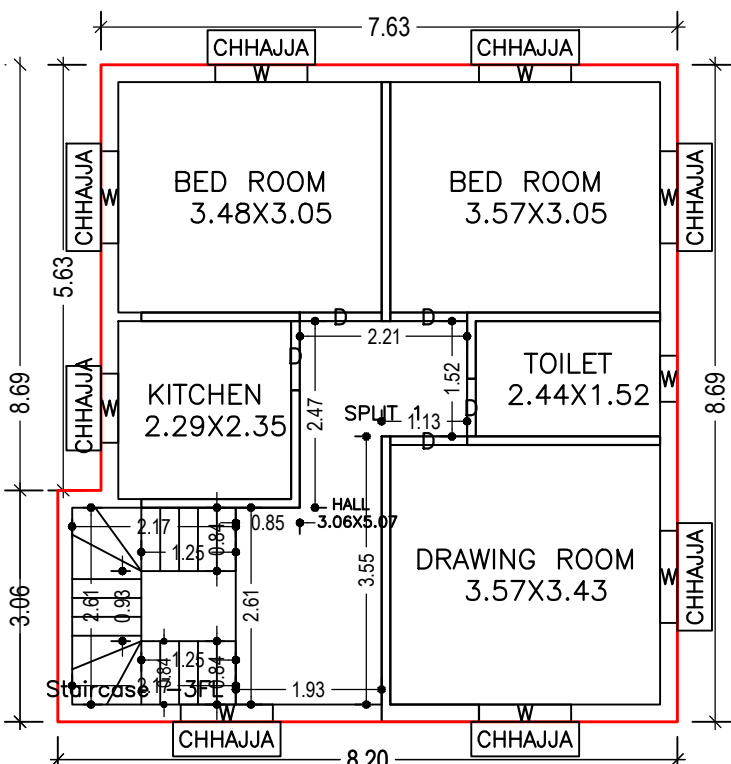

FIRST FLOOR PLAN (Proposed) (SCALE 1:100)

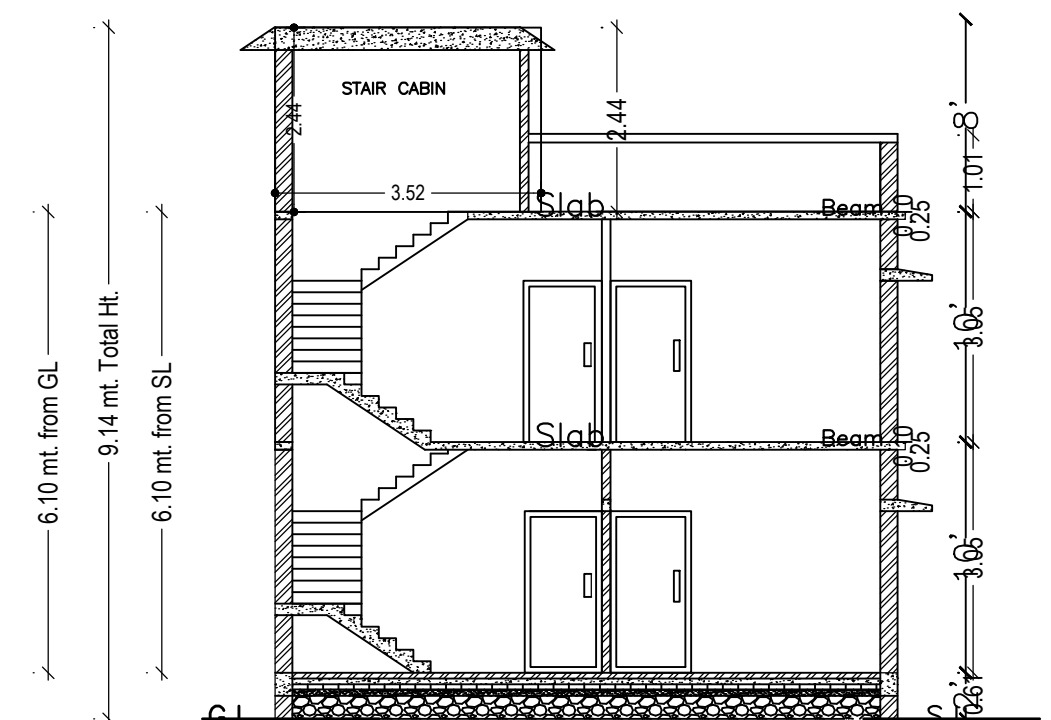

SECTION X-X

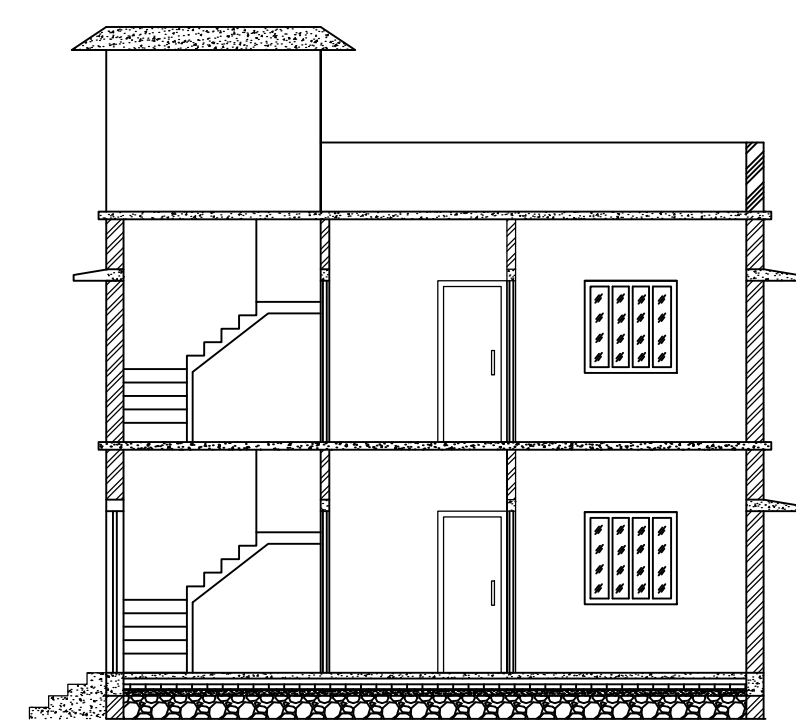

SECTION Y-Y



KEY- PLAN

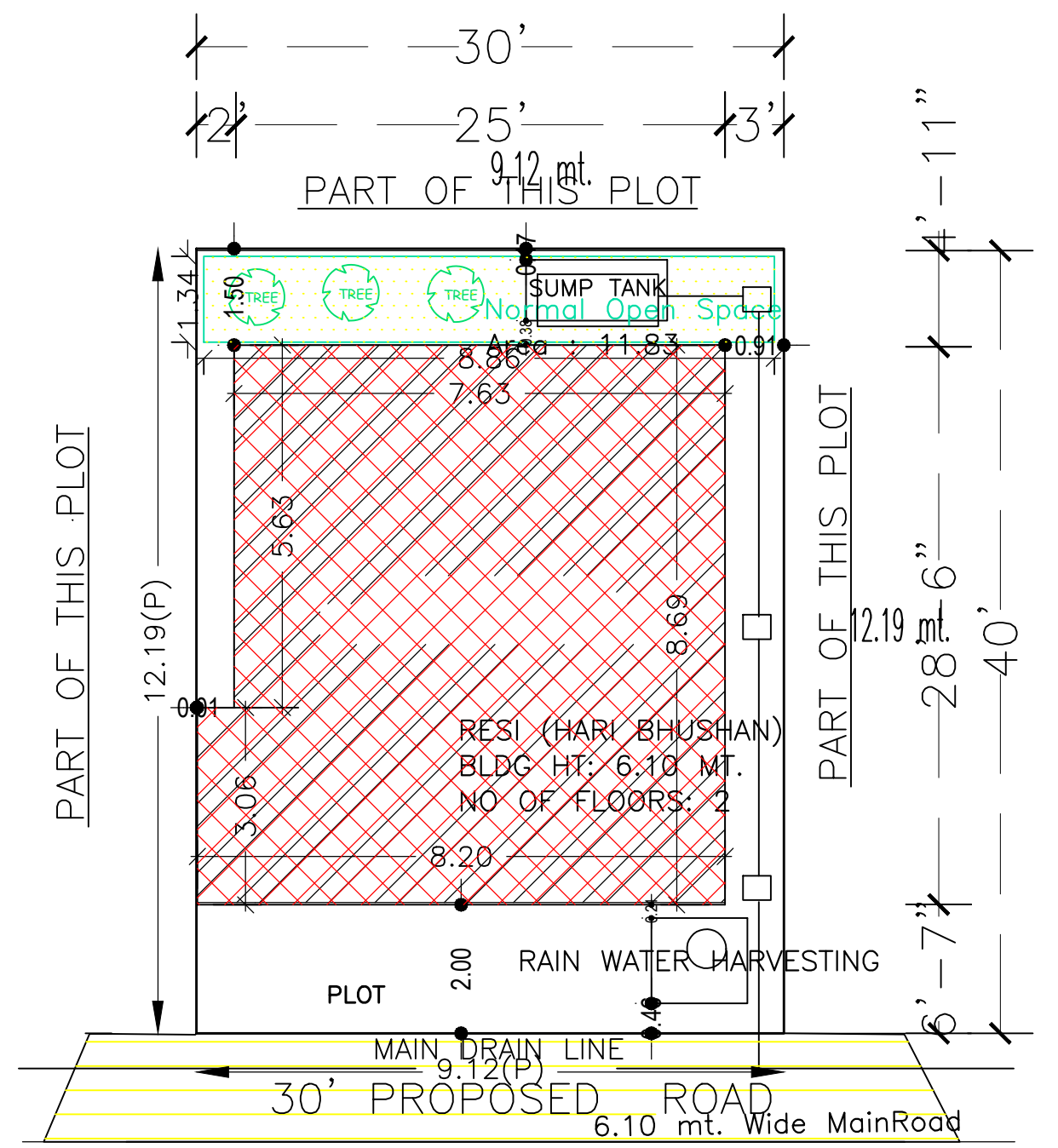

SITE PLAN

AREA STATEMENT MINERAL AREA DEVELOPMENT AUTHORITY	VERSION NO.: 1.0.67	
PROJECT DETAIL:	VERSION DATE: 16/10/2020	
Region: JHARKHAND URBAN LOCAL BODIES	Plot Use: Residential	
District: DHANBAD	Plot SubUse: Bungalow/ Dwelling / Non Apartment	
Authority: MINERAL AREA DEVELOPMENT AUTHORITY	PlotNearby/ReligiousStructure: NA	
Inward No: MADA/BP/0115/2023	Plot/SubPlot No: OLD PLOT NO-314, NEW PLOT NO-455	
Application Type: General Proposal	North: Plot No. - SAME PLOT	
Project Type: Building Permission	South: Plot No. - SAME PLOT	
Nature of Development: New	East: Road Width - 6.10	
Location of Development Area: Old Area	West: Plot No. - SAME PLOT	
AREA DETAILS:	SQ.MT.	
AREA OF PLOT (Minimum)	(A)	111.17
NET AREA OF PLOT(Gross Plot Area - Deduction from Gross Plot area)	(A-Deductions)	111.17
Deduction for Balance Plot Area(from Gross Plot Area)		
Common Plot		11.83
Total		11.83
BALANCE AREA OF PLOT(Net Plot Area - Recreational/Amenity spaces)	(A-Deductions)	99.34
PLOT AREA FOR COVERAGE(Net Plot Area)	(A-Deductions)	111.17
Plot Area for FAR (Net Plot Area + Road/Widening Area)	(A-Deductions)	111.17
COVERAGE CHECK		
Permissible Coverage area (70.00 %)		77.82
Proposed Coverage Area (61.19 %)		68.03
Total Prop. Coverage Area (61.19 %)		68.03
Balance coverage area (8.81 %)		9.79
FAR CHECK		
Perm. FAR Area (2.500)		277.92
Total Perm. FAR area		277.92
Residential FAR		136.06
Proposed FAR Area		136.06
Total Proposed FAR Area		136.06
Consumed FAR (Factor)		1.22
Balance FAR Area		141.86
BUILT UP AREA CHECK		
Total Proposed BuiltUp Area		136.06
ARCHITECT (Regd)		RAM PRATAP SINGH
ENGINEER (Regd)		
SUPERVISOR (Regd)		
OWNER (Regd)		SRI. HARI BHUSHAN KUMAR
DEVELOPMENT AUTHORITY		LOCAL BODY

Buildingwise Floor FAR Details

Floor Name	Building Name		Total	
	Proposed Built Up Area (Sq.mt.)	Proposed FAR Area (Sq.mt.)	Total Proposed Built Up Area (Sq.mt.)	Total FAR Area (Sq.mt.)
Ground Floor	68.03	68.03	68.03	68.03
First Floor	68.03	68.03	68.03	68.03
Terrace Floor	0.00	0.00	0.00	0.00
Total :	136.06	136.06	136.06	136.06

UnitBUA Table for Building :RESI (HARI BHUSHAN)

FLOOR	Name	UnitBUA Type	UnitBUA Area	Carpet Area	No. of Rooms	No. of Tenement
GROUND FLOOR	SPLIT 1	FLAT	134.19	129.72	5	1
FIRST FLOOR	SPLIT 1	FLAT	0.00	0.00	6	0
Total:	-	-	134.19	129.72	11	1

Building :RESI (HARI BHUSHAN)

Floor Name	Total Built Up Area (Sq.mt.)	Proposed FAR Area (Sq.mt.)	Total FAR Area (Sq.mt.)	Total Consumed Additional FAR Area (Sq.mt.)	Tnmt (No.)
Ground Floor	68.03	68.03	68.03	68.03	01
First Floor	68.03	68.03	68.03	68.03	00
Terrace Floor	0.00	0.00	0.00	0.00	00
Total :	136.06	136.06	136.06	136.06	01
Total Number of Same Buildings	1				
Total :	136.06	136.06	136.06	136.06	01

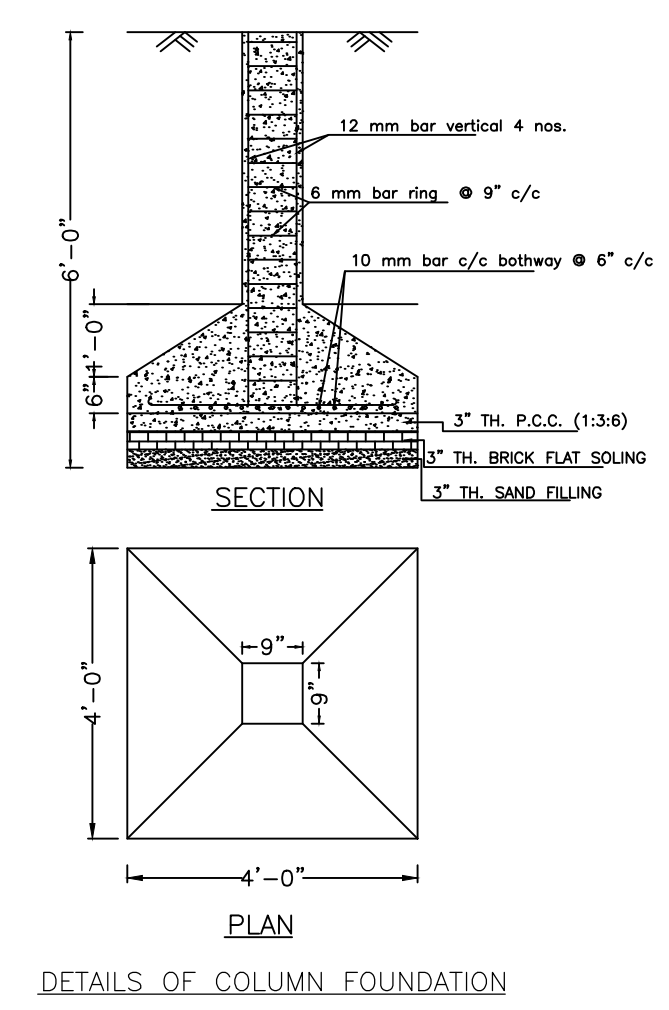

DETAILS OF COLUMN FOUNDATION

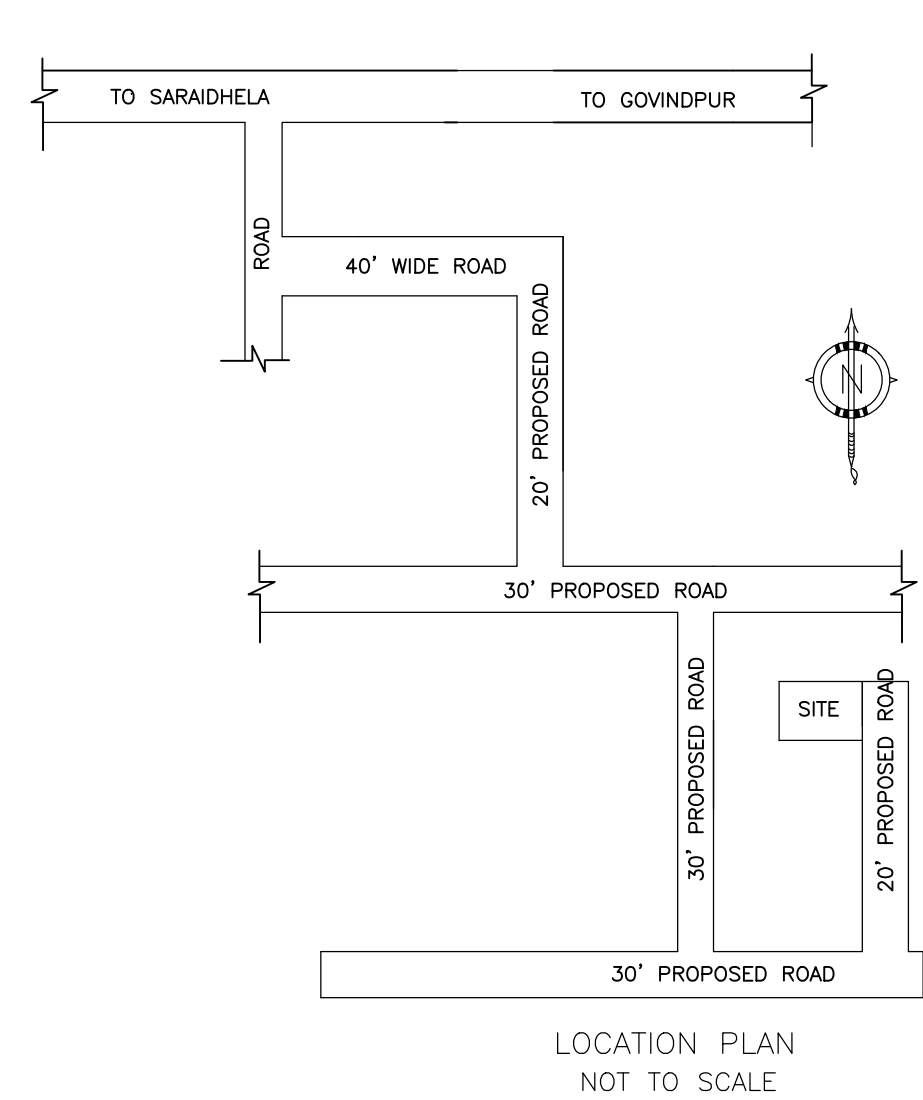

LOCATION PLAN NOT TO SCALE

FAR & Tenement Details (Table 4c-1)

Building	No. of Same Bldg	Total Built Up Area (Sq.mt.)	Proposed FAR Area (Sq.mt.)	Total FAR Area (Sq.mt.)	Total Consumed Additional FAR Area (Sq.mt.)	Tnmt (No.)
RESI (HARI BHUSHAN)	1	136.06	136.06	136.06	136.06	01
Grand Total :	1	136.06	136.06	136.06	136.06	01

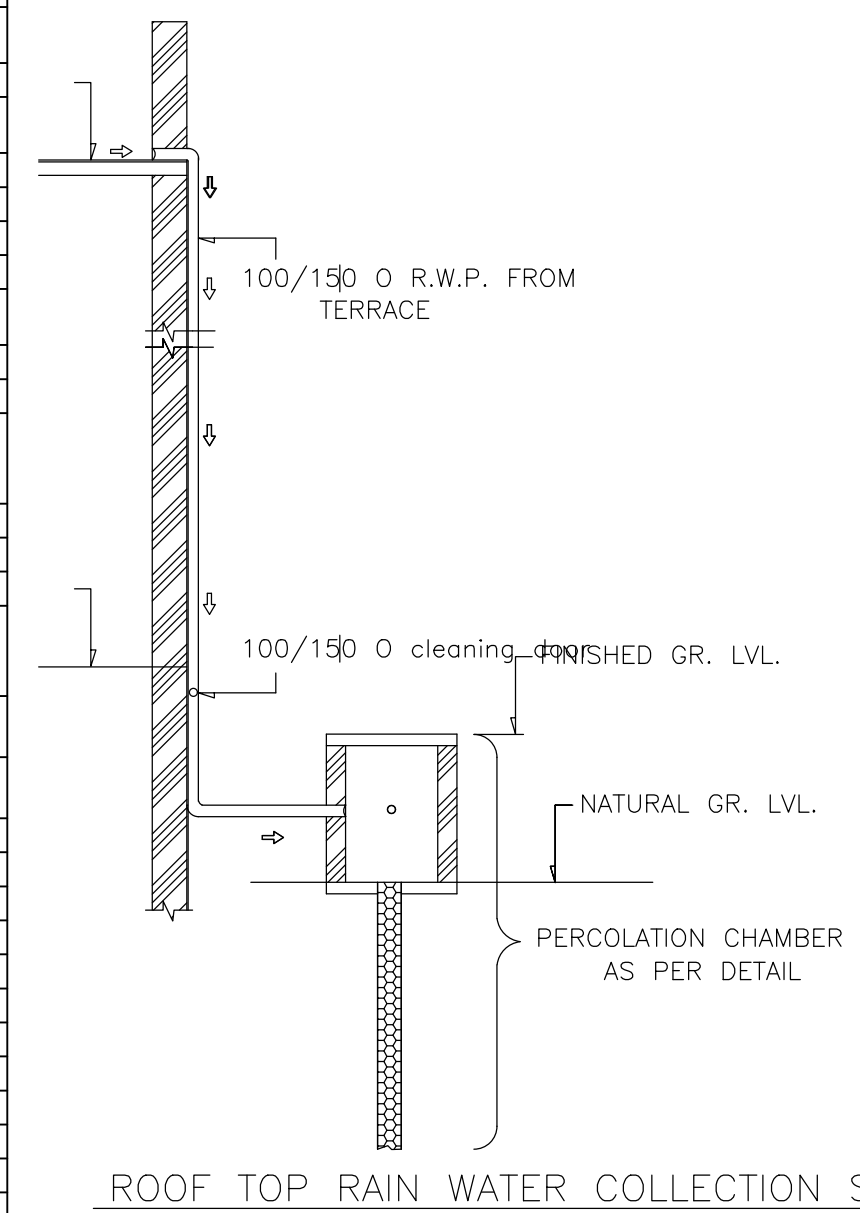

ROOF TOP RAIN WATER COLLECTION SYSTEM

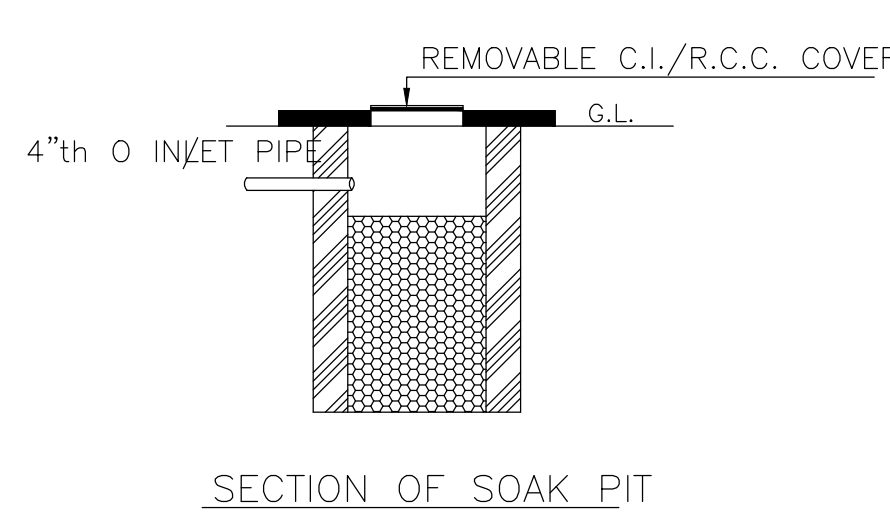

SECTION OF SOAK PIT

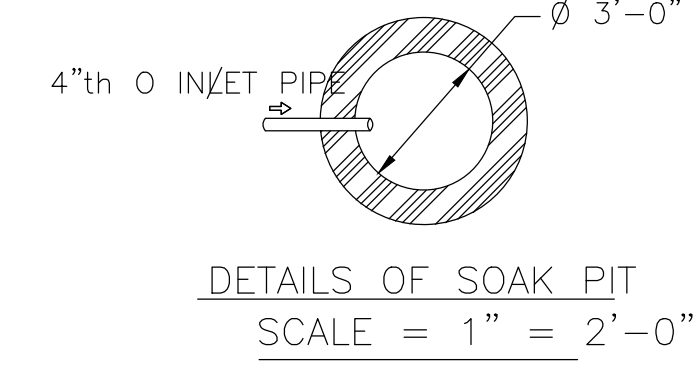

DETAILS OF SOAK PIT SCALE = 1" = 2'-0"

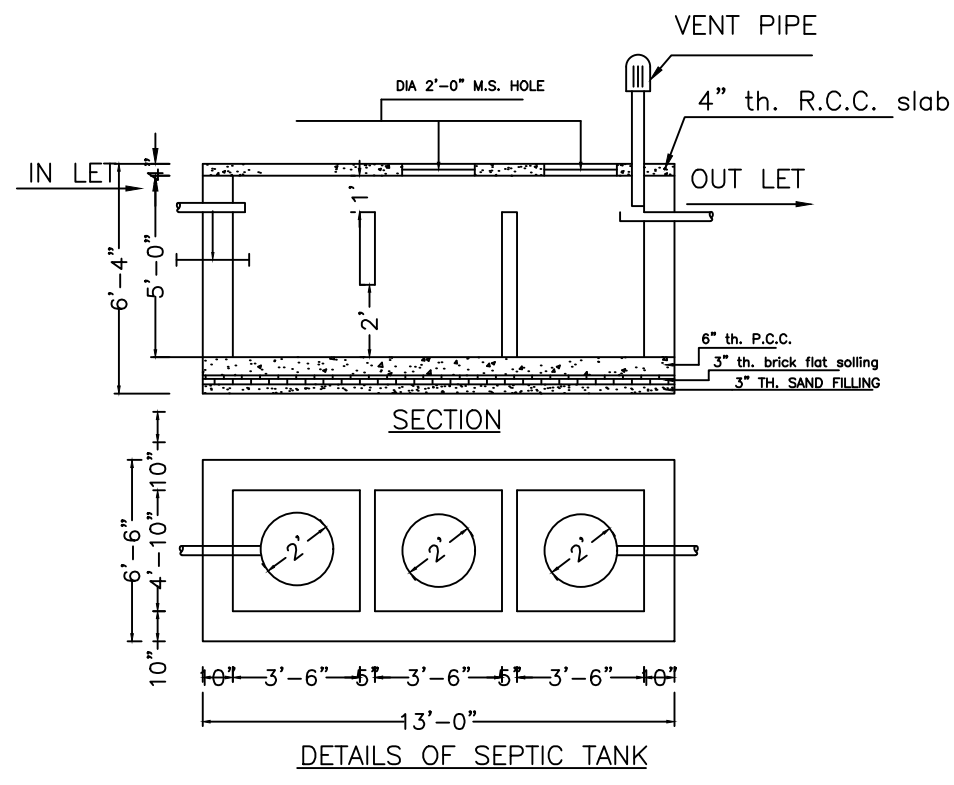

DETAILS OF SEPTIC TANK

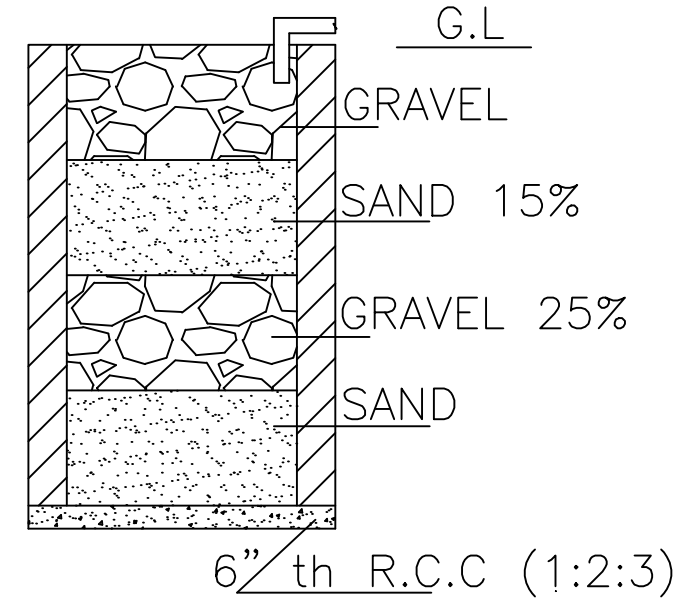

SECTION ON A-B

DETAILS DRAWING OF RAIN WATER HARVESTING

SCHEDULE OF DOOR:

BUILDING NAME	NAME	LENGTH	HEIGHT	NOS
RESI (HARI BHUSHAN)	D	0.76	2.10	02
RESI (HARI BHUSHAN)	D	0.92	2.10	02
RESI (HARI BHUSHAN)	D	1.02	2.10	04
RESI (HARI BHUSHAN)	D	1.08	2.10	02

SCHEDULE OF WINDOW/VENTILATION:

BUILDING NAME	NAME	LENGTH	HEIGHT	NOS
RESI (HARI BHUSHAN)	W	0.61	1.20	02
RESI (HARI BHUSHAN)	W	0.92	1.20	02
RESI (HARI BHUSHAN)	W	1.22	1.20	14

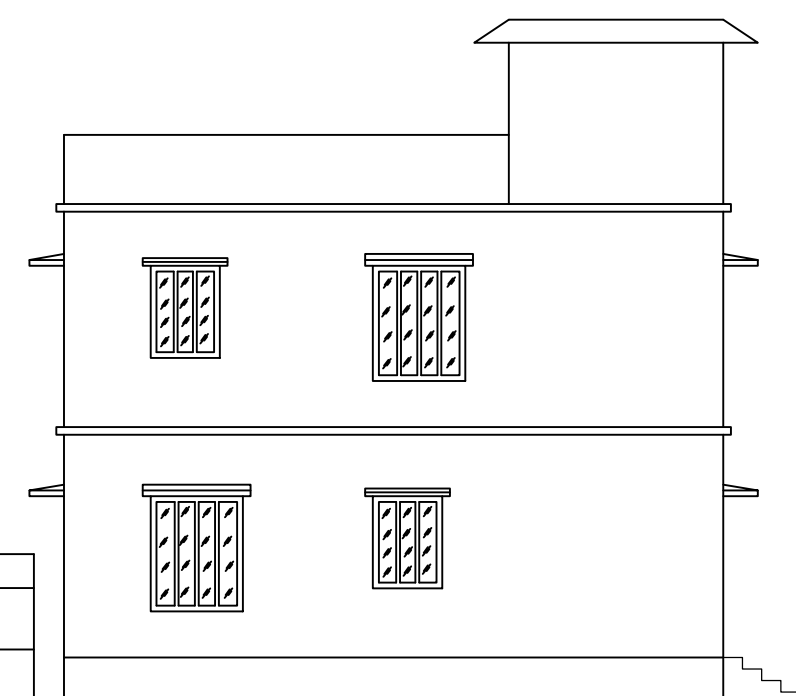

LEFT SIDE ELEVATION

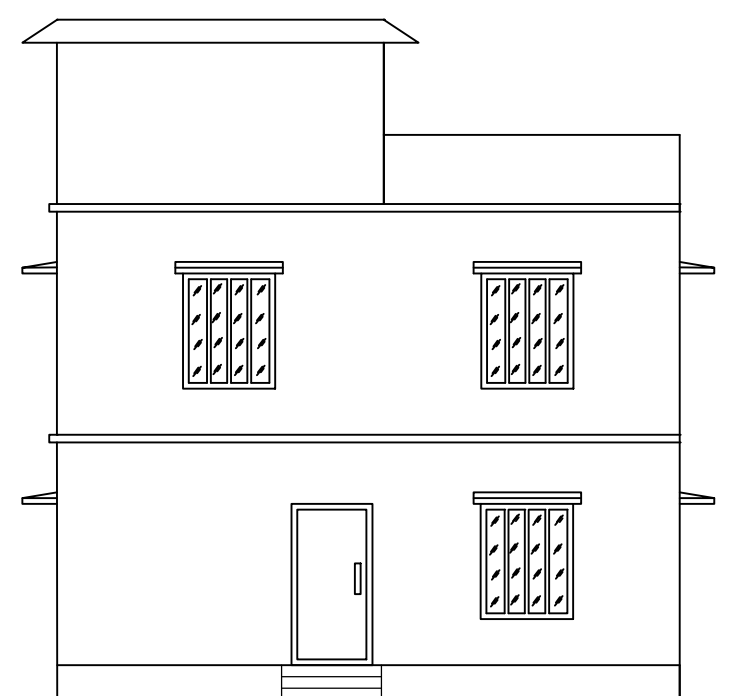

FRONT ELEVATION

LTP NAME AND SIGNATURE	STRUCTURAL ENG'S NAME AND SIGNATURE	BUILDER NAME AND SIGNATURE	DIGITAL SIGNATURE
RAM PRATAP SINGH MADA/ARC/0024/2019			