

SITE PLAN
SCALE - 1" = 8'-0"

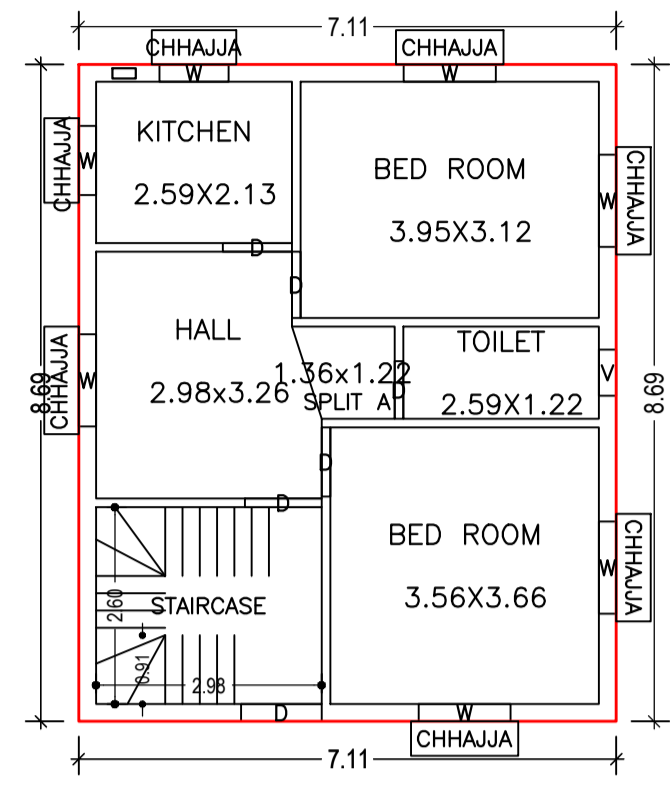

GROUND FLOOR PLAN (Proposed)
SCALE 1:100

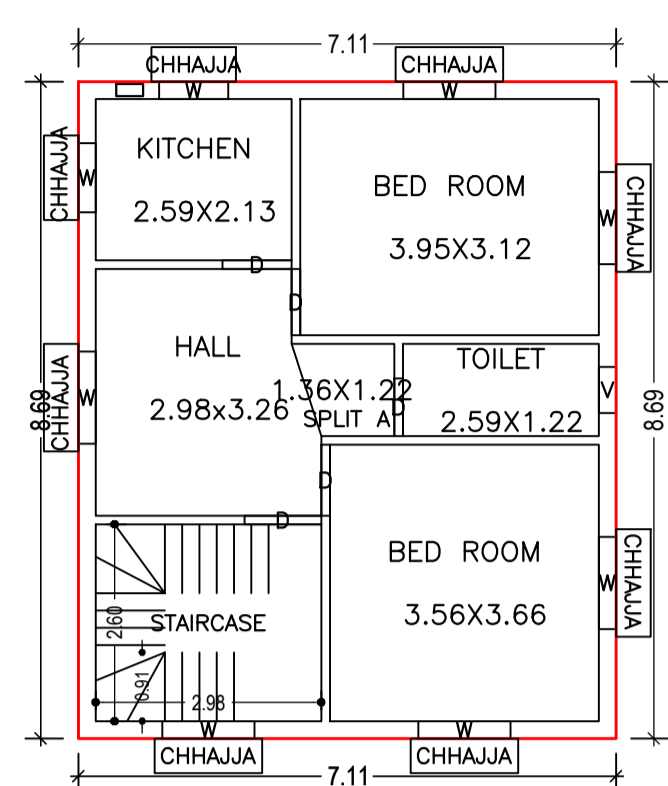

FIRST FLOOR PLAN (Proposed)
SCALE 1:100

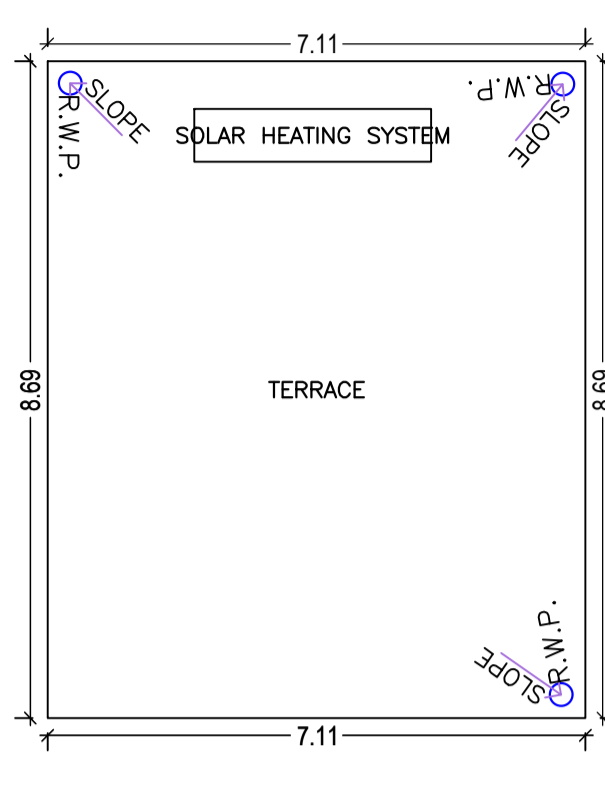

TERRACE FLOOR PLAN (SCALE 1:100)

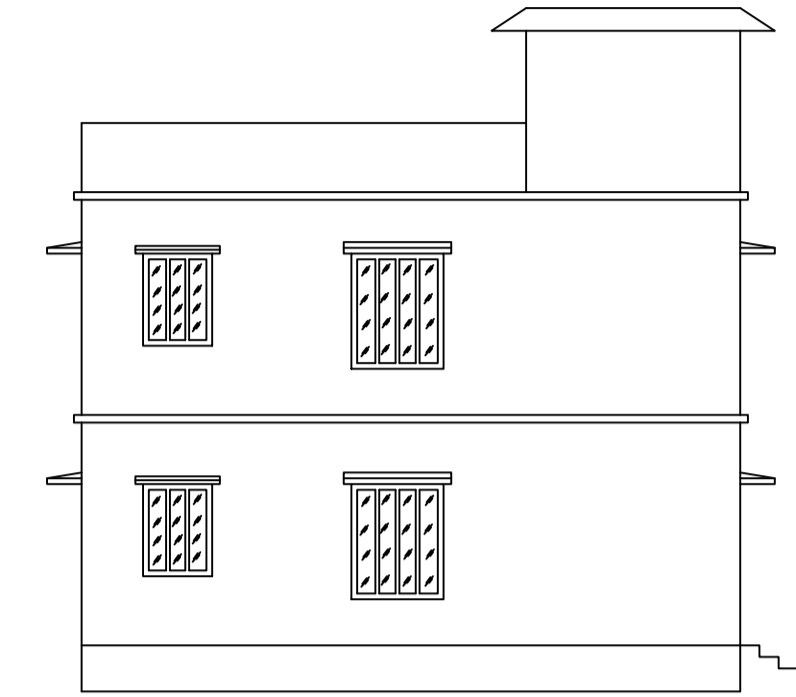

LEFT SIDE ELEVATION
SCALE - 1" = 8'-0"

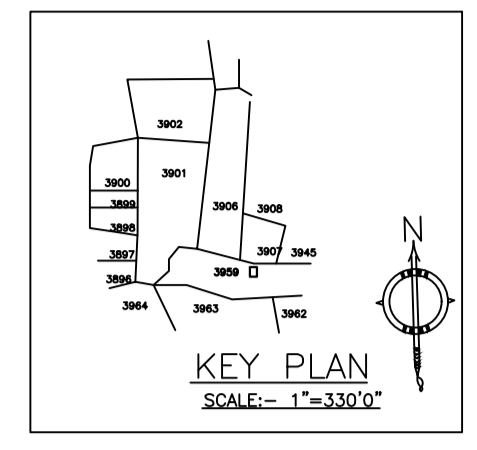

Proposal Basic Information

Proposal File No.	MADA/BP/0113/2023
Owner Name	1. SMT. LAGINA DEVI AND 2. SRI RAHUL KUMAR RAHI
Khata No	OLD KHATA NO-55, NEW KHATA NO-215
Plot No	OLD PLOT NO-2533 & 2533, NEW PLOT NO-3959 & 3959
Village Name	Bara Pichari
Use	Residential
SubUse	Bungalow/ Dwelling / Non Apartment

AREA STATEMENT MINERAL AREA DEVELOPMENT AUTHORITY	VERSION NO.: 1.0.66 VERSION DATE: 16/10/2020	SQ.MT.
PROJECT DETAIL:		
Region: JHARKHAND URBAN LOCAL BODIES	Plot Use: Residential	
District: DHANBAD	Plot SubUse: Bungalow/ Dwelling / Non Apartment	
Authority: MINERAL AREA DEVELOPMENT AUTHORITY	Plot/Nearby/Religious Structure: NA	
Inward No: MADA/BP/0113/2023	Plot/SubPlot No: OLD PLOT NO-2533 & 2533, NEW PLOT NO-3959 & 3959	
Application Type: General Proposal	North: Plot No. - SAME PLOT	
Project Type: Building Permission	South: Plot No. - SAME PLOT	
Nature of Development: New	East: Plot No. - SAME PLOT	
Location of Development Area: Old Area	West: Road Width - 6.10	
AREA DETAILS:		
AREA OF PLOT (Minimum)	(A)	111.00
NET AREA OF PLOT (Gross Plot Area - Deduction from Gross Plot area)	(A-Deductions)	111.00
Deduction for Balance Plot Area (from Gross Plot Area)		
Common Plot		13.29
Total		13.29
BALANCE AREA OF PLOT (Net Plot Area - Recreational/Amenity space)	(A-Deductions)	97.71
PLOT AREA FOR COVERAGE (Net Plot Area)	(A-Deductions)	111.00
Plot Area for FAR (Net Plot Area + Road/Widening Area)	(A-Deductions)	111.00
COVERAGE CHECK		
Permissible Coverage area (70.00 %)		77.70
Proposed Coverage Area (55.66 %)		61.78
Total Prop. Coverage Area (55.66 %)		61.78
Balance coverage area (14.34 %)		15.92
FAR CHECK		
Perm. FAR Area (2.500)		277.50
Total Perm. FAR area		277.50
Residential FAR		123.56
Proposed FAR Area		123.56
Total Proposed FAR Area		123.56
Consumed FAR (Factor)		1.11
Balance FAR Area		153.94
BUILT UP AREA CHECK		
Total Proposed BuiltUp Area		123.56
ARCHITECT (Regd)		
ENGINEER (Regd)		RAM PRATAP SINGH
SUPERVISOR (Regd)		
OWNER (Regd)		1. SMT. LAGINA DEVI AND 2. SRI RAHUL KUMAR RAHI
DEVELOPMENT AUTHORITY		
		LOCAL BODY

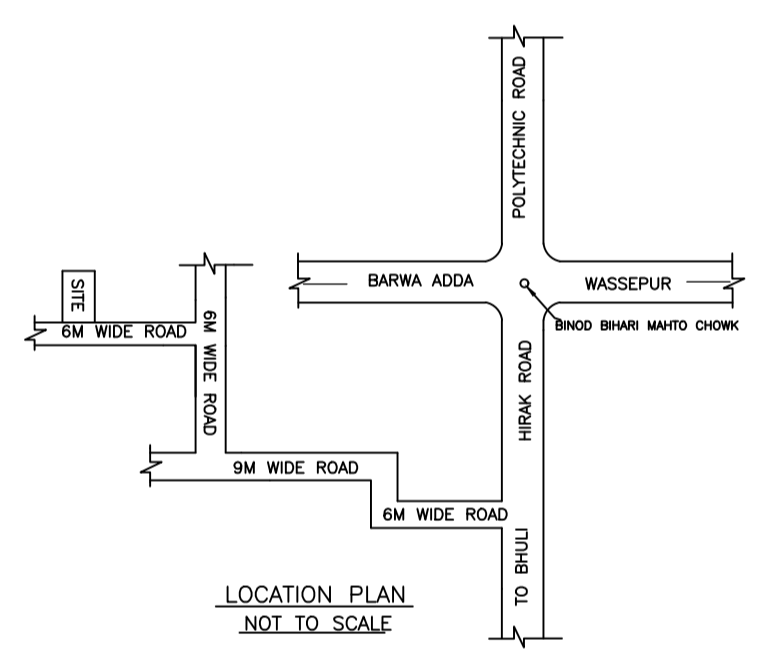

LOCATION PLAN
NOT TO SCALE

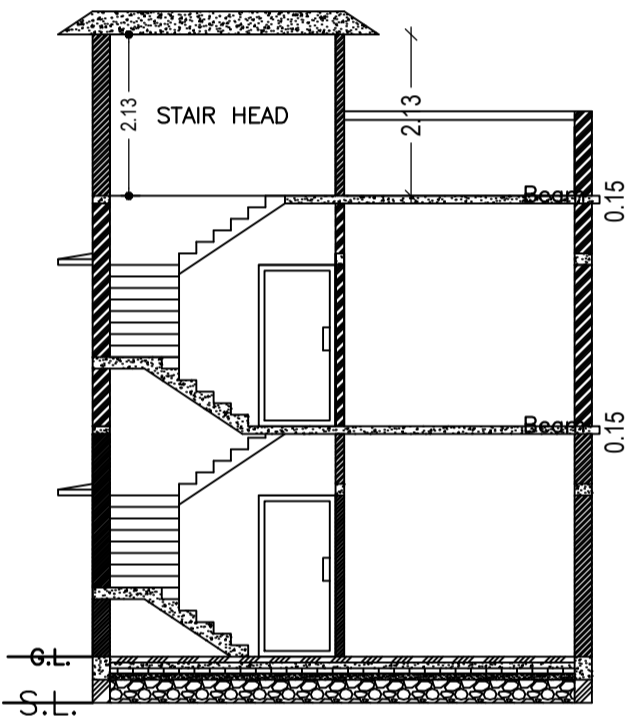

SECTION X-X
SCALE - 1" = 8'-0"

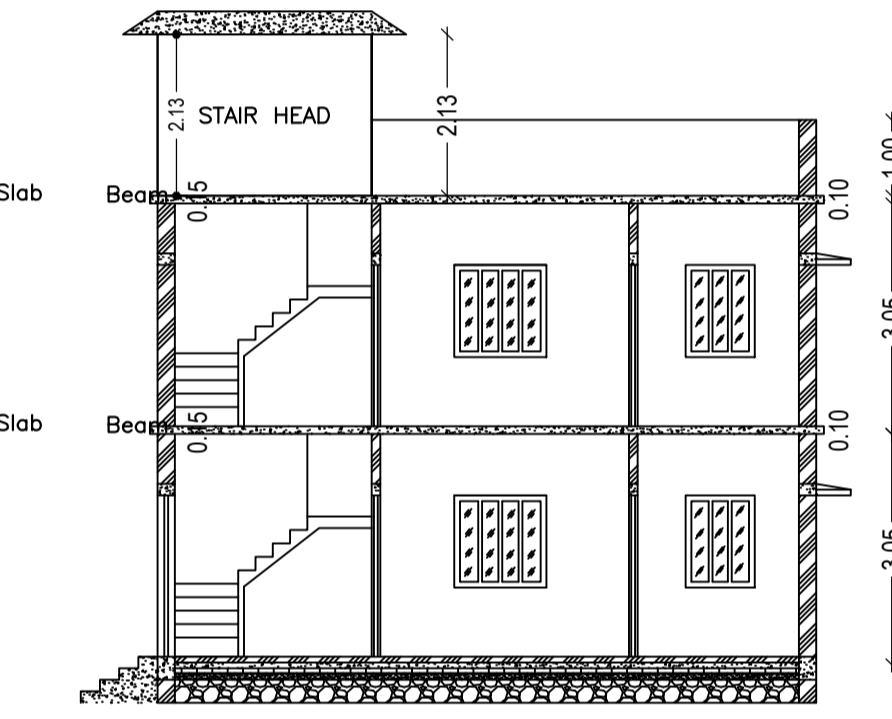

SECTION Y-Y
SCALE - 1" = 8'-0"

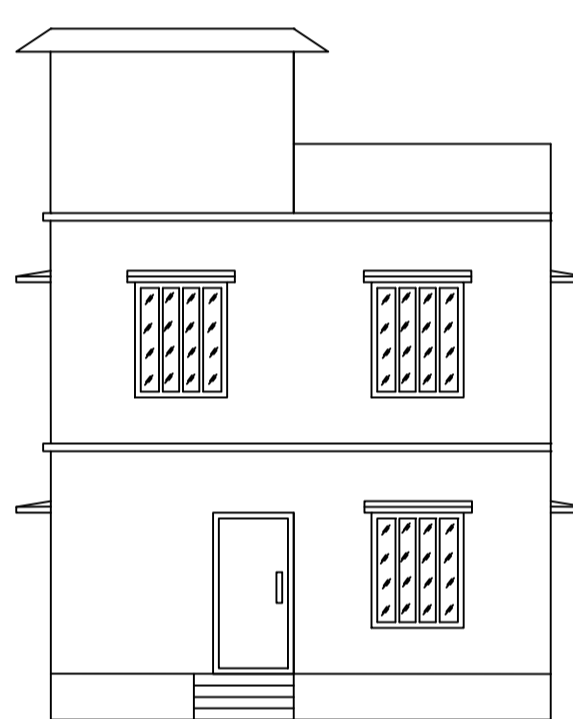

FRONT ELEVATION
SCALE - 1" = 8'-0"

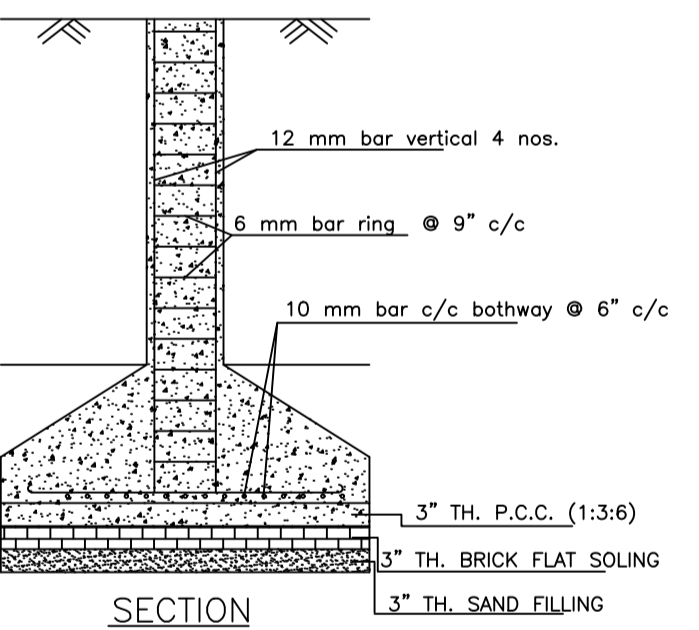

SECTION

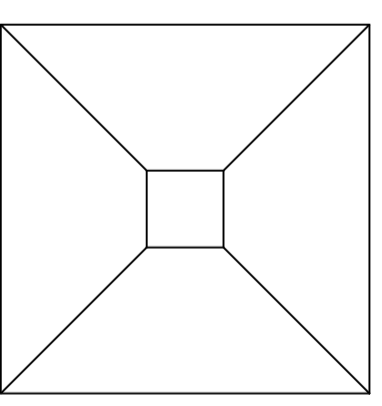

PLAN

DETAILS OF COLUMN FOUNDATION
SCALE - 1" = 2'-0"

Building :A (1 LAGINA AND 2 RAHUL)

Floor Name	Total Built Up Area (Sq.mt.)	Proposed FAR Area (Sq.mt.) Resi.	Total FAR Area (Sq.mt.)	Total Consumed Additional FAR Area (Sq.mt.)	Tnmt (No.)
Ground Floor	61.78	61.78	61.78	61.78	01
First Floor	61.78	61.78	61.78	61.78	00
Terrace Floor	0.00	0.00	0.00	0.00	00
Total:	123.56	123.56	123.56	123.56	01
Total Number of Same Buildings	1				
Total:	123.56	123.56	123.56	123.56	01

SCHEDULE OF DOOR:

BUILDING NAME	NAME	LENGTH	HEIGHT	NOS
A (1 LAGINA AND 2 RAHUL)	D	0.76	2.10	02
A (1 LAGINA AND 2 RAHUL)	D	0.88	2.10	02
A (1 LAGINA AND 2 RAHUL)	D	0.91	2.10	03
A (1 LAGINA AND 2 RAHUL)	D	0.94	2.10	01
A (1 LAGINA AND 2 RAHUL)	D	1.02	2.10	02

SCHEDULE OF WINDOW/VENTILATION:

BUILDING NAME	NAME	LENGTH	HEIGHT	NOS
A (1 LAGINA AND 2 RAHUL)	V	0.61	1.20	02
A (1 LAGINA AND 2 RAHUL)	W	0.91	1.20	04
A (1 LAGINA AND 2 RAHUL)	W	1.22	1.20	11

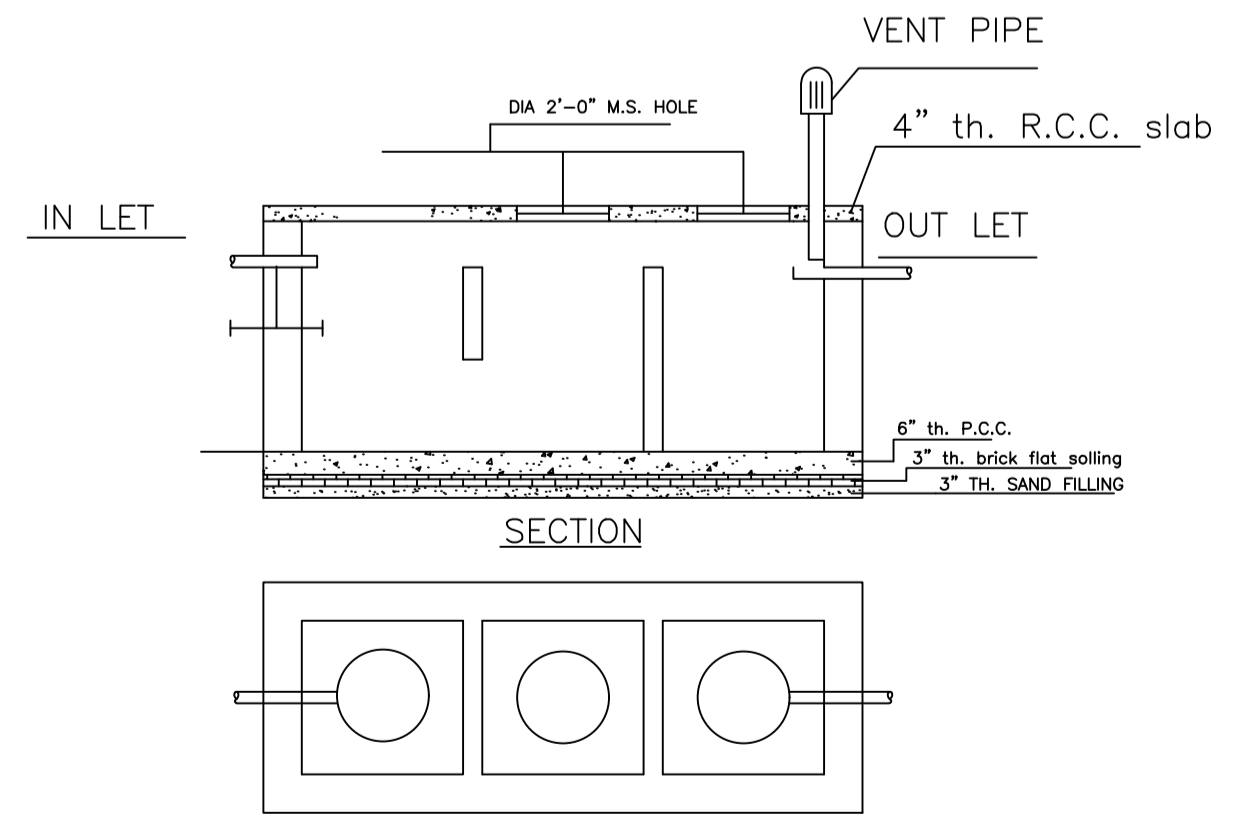

DETAILS OF SEPTIC TANK
SCALE - 1" = 4'-0"

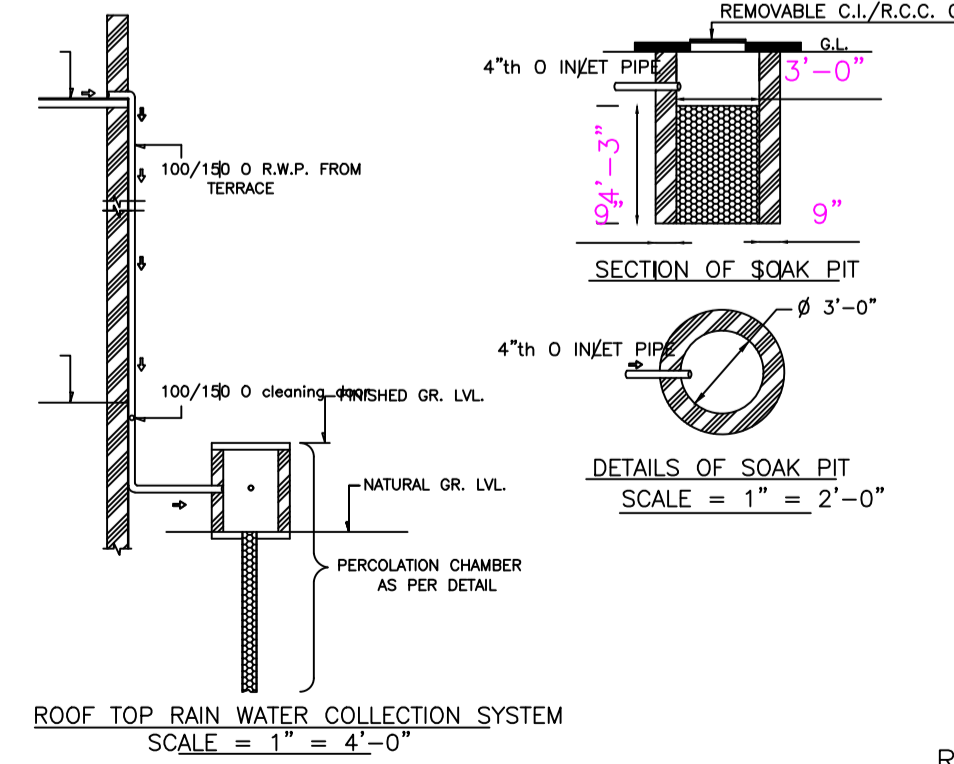

ROOF TOP RAIN WATER COLLECTION SYSTEM
SCALE = 1" = 4'-0"

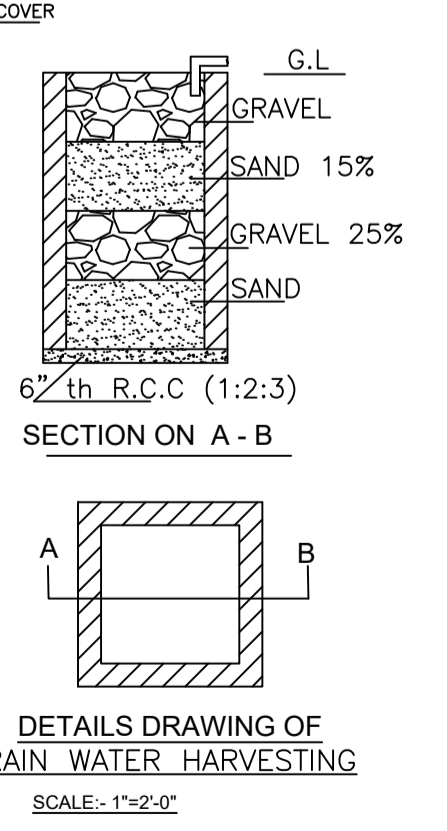

DETAILS DRAWING OF FOUNDATION
SCALE- 1"=2'-0"

COLOR INDEX

PLOT BOUNDARY	Black
ABUTTING ROAD	Red
PROPOSED CONSTRUCTION	Green
COMMON PLOT	Yellow
ROAD WIDENING AREA	Blue
EXISTING (To be retained)	Orange
EXISTING (To be demolished)	Purple

Buildingwise Floor FAR Details

Floor Name	Building Name		Total	
	A (1 LAGINA AND 2 RAHUL)	Total Proposed Built Up Area (Sq.mt.)	Proposed FAR Area (Sq.mt.)	Total FAR Area (Sq.mt.)
Ground Floor	61.78	61.78	61.78	61.78
First Floor	61.78	61.78	61.78	61.78
Terrace Floor	0.00	0.00	0.00	0.00
Total:	123.56	123.56	123.56	123.56

Building USE/SUBUSE Details

Building Name	Building Use	Building SubUse	Building Structure
A (1 LAGINA AND 2 RAHUL)	Residential	Bungalow/ Dwelling / Non Apartment	Non-Highrise

FAR & Tenement Details (Table 4c-1)

Building	No. of Same Bldg	Total Built Up Area (Sq.mt.)	Proposed FAR Area (Sq.mt.) Resi.	Total FAR Area (Sq.mt.)	Total Consumed Additional FAR Area (Sq.mt.)	Tnmt (No.)
A (1 LAGINA AND 2 RAHUL)	1	123.56	123.56	123.56	123.56	01
Grand Total:	1	123.56	123.56	123.56	123.56	01

UnitBUA Table for Building :A (1 LAGINA AND 2 RAHUL)

FLOOR	Name	UnitBUA Type	UnitBUA Area	Carpet Area	No. of Rooms	No. of Tenement
GROUND FLOOR PLAN	SPLIT A	FLAT	123.56	123.46	5	1
FIRST FLOOR PLAN	SPLIT A	FLAT	0.00	0.00	5	0
Total:	-	-	123.56	123.46	10	1

LTP NAME AND SIGNATURE	STRUCTURAL ENG'S NAME AND SIGNATURE	BUILDER NAME AND SIGNATURE	DIGITAL SIGNATURE
RAM PRATAP SINGH MADA/ARC/0024/2019			