

Proposal Basic Information	
Proposal File No.	MADA/BP/0165/2023
Owner Name	SMT. SUSHILA DEVI
Khata No.	OLD KHATA NO-34, NEW KHATA NO-5
Plot No.	OLD PLOT NO-515, NEW PLOT NO-1458
Village Name	Jalgora
Use	Residential
SubUse	Bungalow Dwelling / Non Apartment

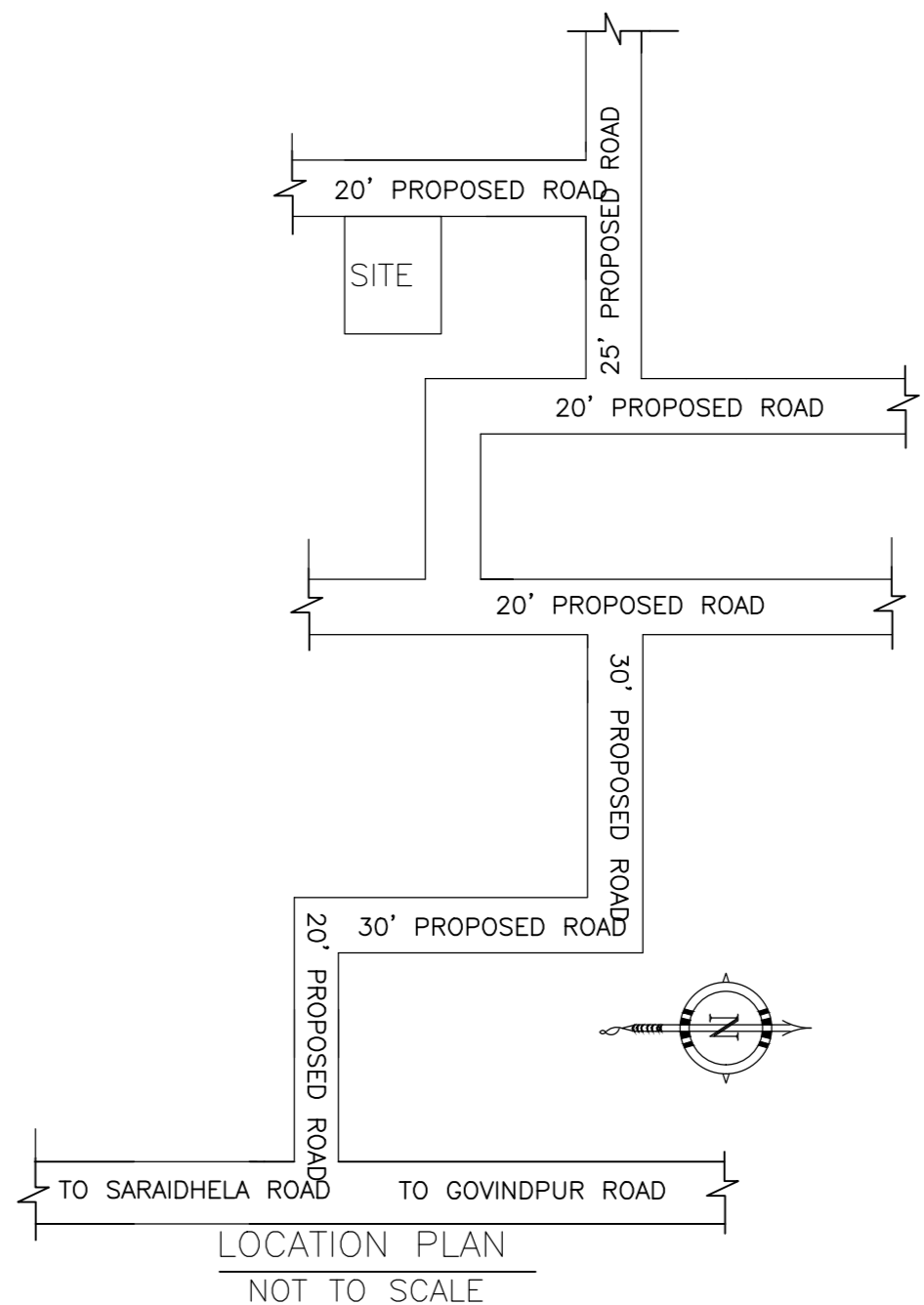
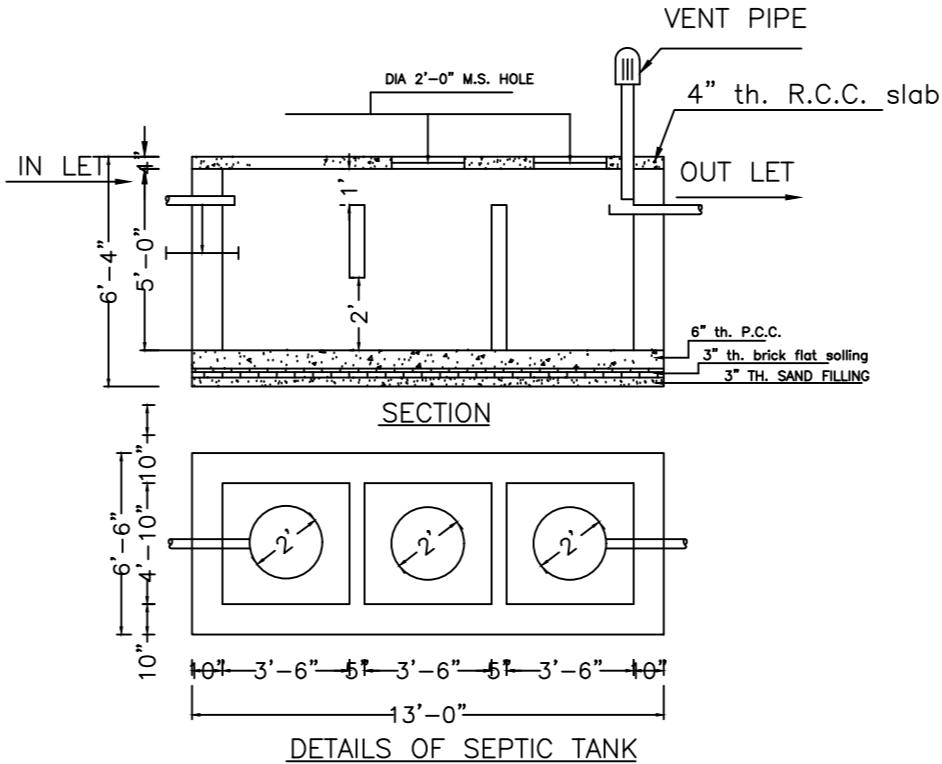
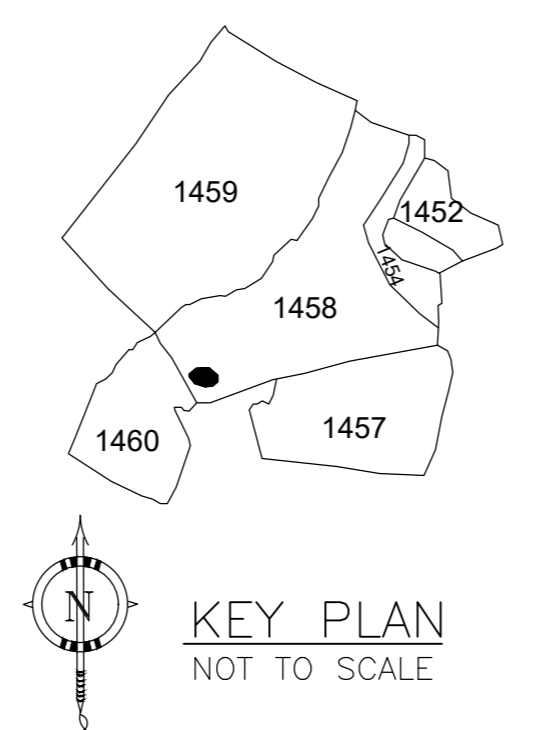
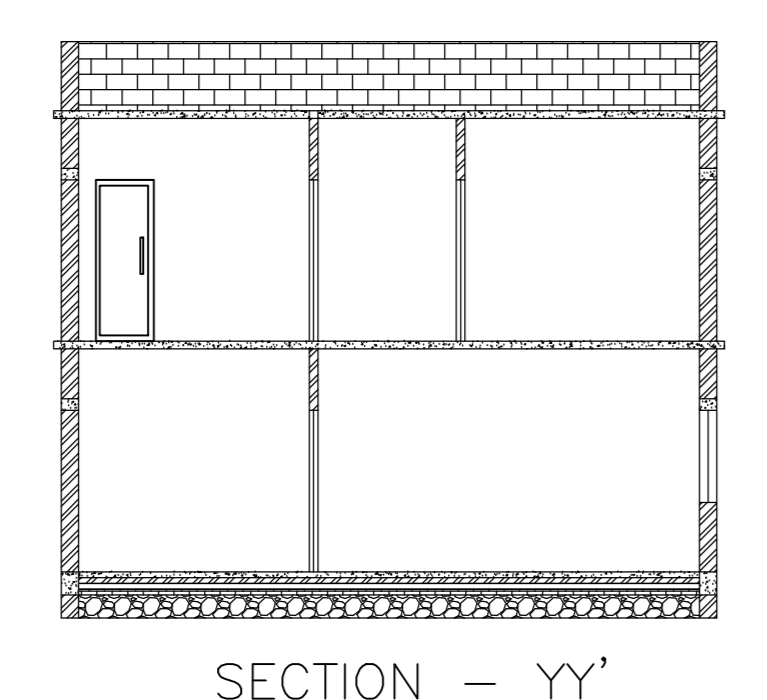
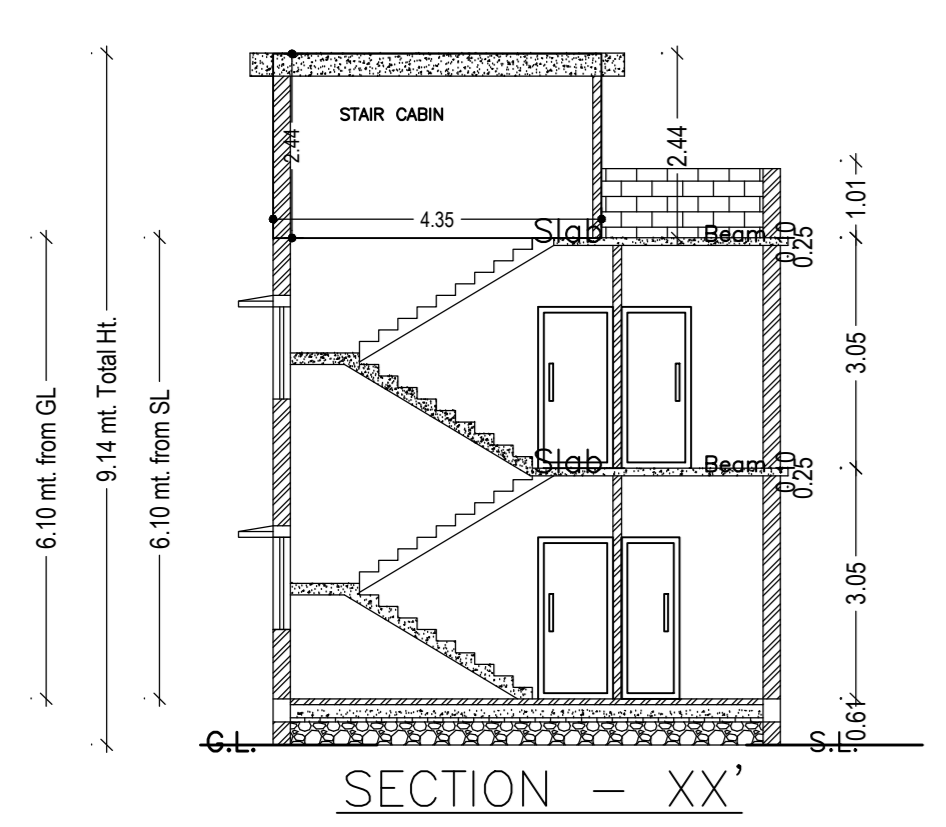
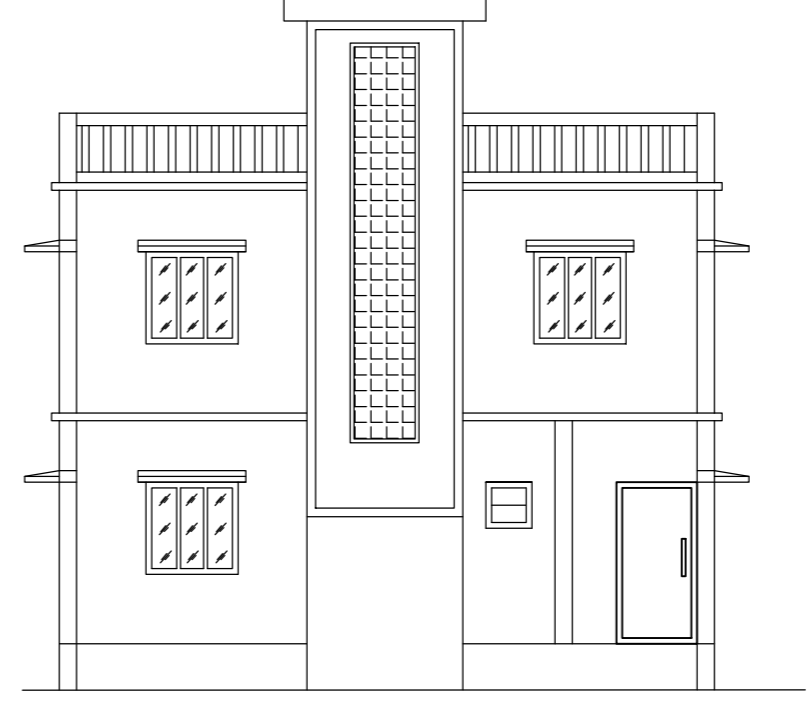
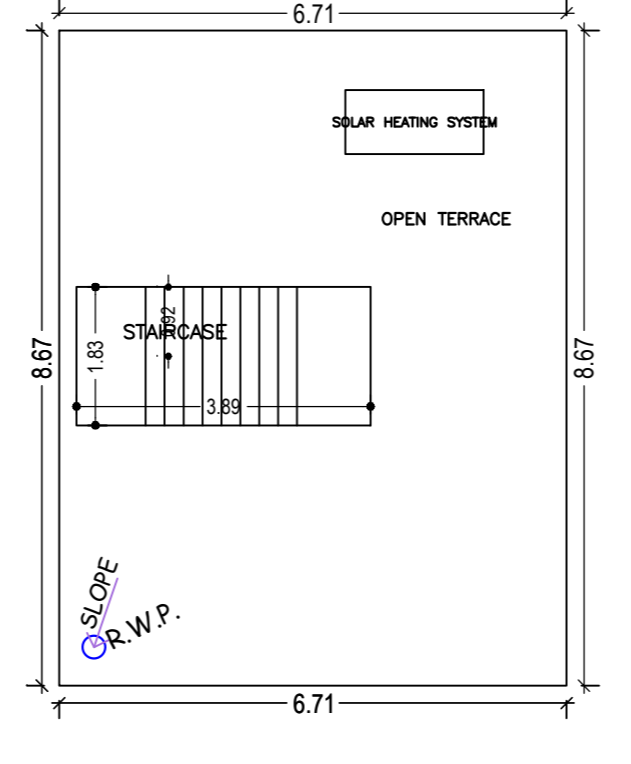
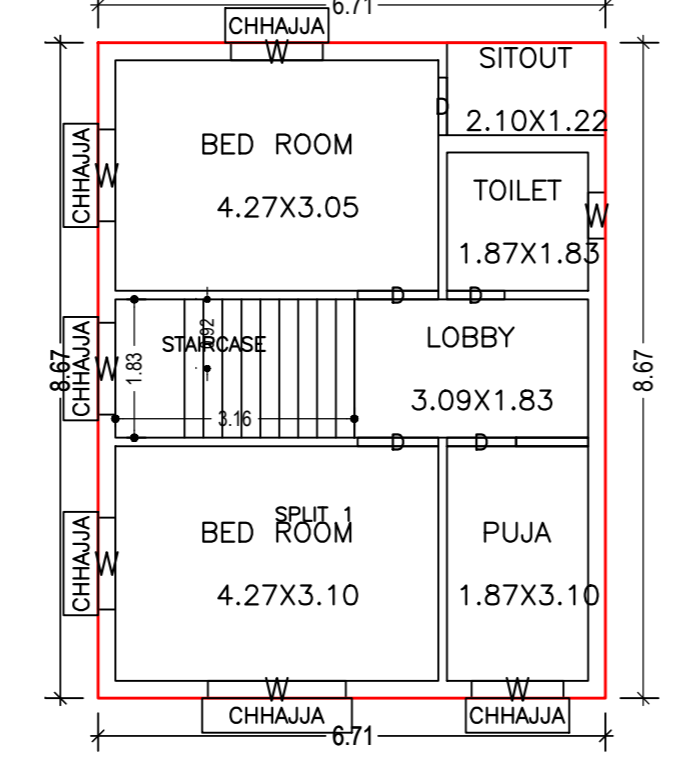
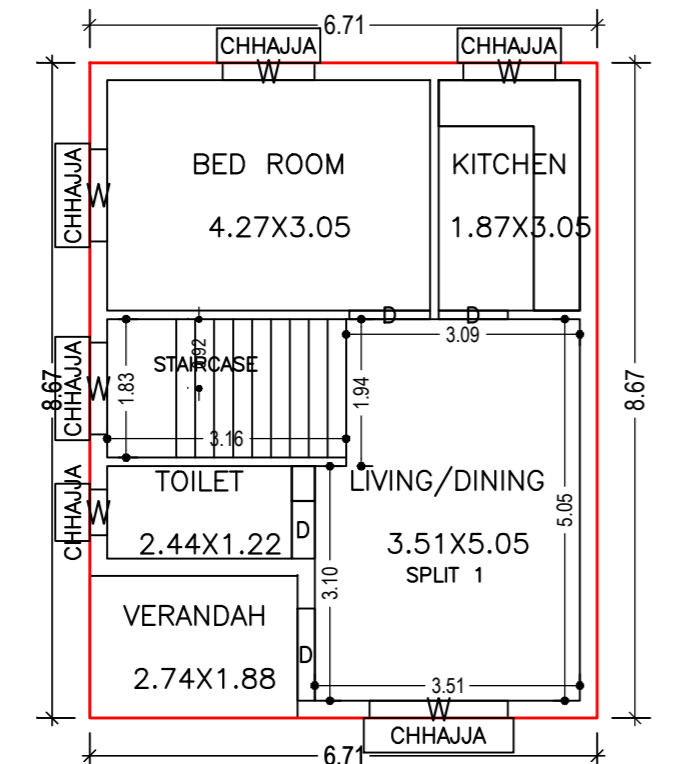
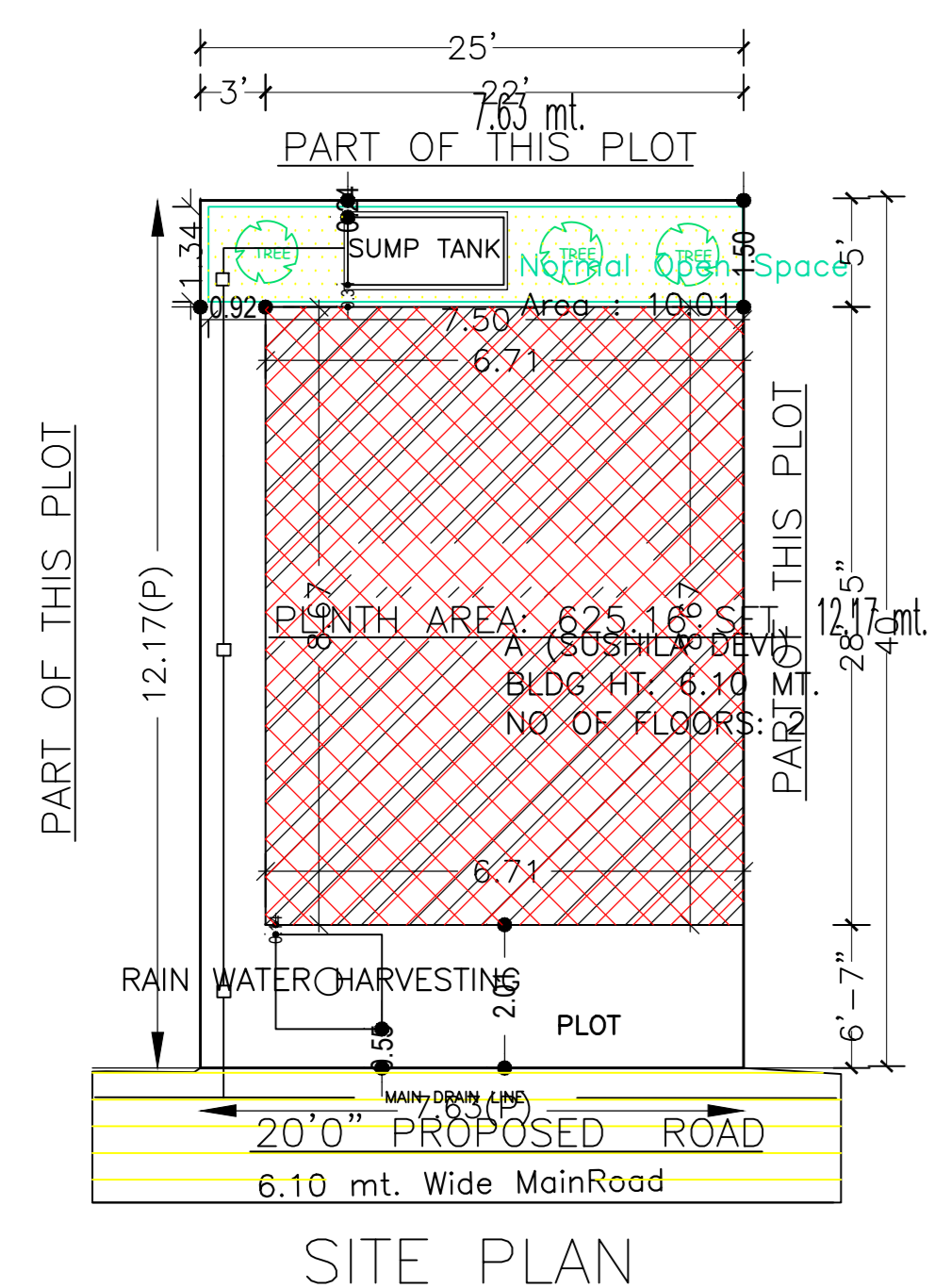

AREA STATEMENT MINERAL AREA DEVELOPMENT AUTHORITY	VERSION NO. 1.0.66	VERSION DATE: 16/09/2020
PROJECT DETAIL	Plot Use: Residential	
Region: JHARKHAND URBAN LOCAL BODIES	Plot SubUse: Bungalow Dwelling / Non Apartment	
District: DHANBAD	Plot/Neary/Religious/Structure: NA	
Authority: MINERAL AREA DEVELOPMENT AUTHORITY	North: Plot No. - SAME PLOT	
Invest. No. MADABP/165/2023	South: Plot No. - SAME PLOT	
Application Type: General Proposal	East: Plot No. - SAME PLOT	
Project Type: Building Permission	West: Road Width - 6.10	
Nature of Development: New		
Location of Development Area: DG Area		
AREA DETAILS:	AREA OF PLOT (Minimum)	92.80
NET AREA OF PLOT/Gross Plot Area	(A-Deductions)	92.80
Deduction for Balance Plot Area/From Gross Plot Area		10.01
Common Plot		10.01
BALANCE AREA OF PLOT/Net Plot Area - Recreational/Amenity space)	(A-Deductions)	82.78
Plot Area for FAR (Net Plot Area - Road/Walking Area)	(A-Deductions)	92.80
Plot Area for FAR (Net Plot Area - Road/Walking Area)	(A-Deductions)	92.80
COVERAGES CHECK		
Minimum Coverage area (70.32 %)		64.96
Proposed Coverage area (62.67 %)		58.16
Total Prop. Coverage Area (62.67 %)		58.16
Balance coverage area (7.33 %)		6.80
FAR CHECK (1:1:1)		
Plot FAR Area (2.500)		232.00
Total Plotted FAR area		232.00
Residential FAR		116.31
Proposed FAR Area		116.31
Total Proposed FAR Area		116.31
Consumed FAR (FAR)		1.25
Balance FAR Area		115.06
BUILT UP AREA CHECK		
Total Proposed Built Up Area		116.32
ARCHITECT (Regd)	RAM PRATAP SINGH	
ENGINEER (Regd)	SMT. SUSHILA DEVI	
SUPERVISOR (Regd)	SMT. SUSHILA DEVI	
OWNER (Regd)	SMT. SUSHILA DEVI	

COLOR INDEX	
Plot Boundary	Black
Abutting Road	Red
Proposed Construction	Green
Common Plot	Yellow
Road Widening Area	Blue
Existing (To be retained)	Orange
Existing (To be demolished)	Purple

Buildingwise Floor FAR Details				
Floor Name	Building Name	Proposed FAR Area (Sq.mt.)	Total Proposed Built Up Area (Sq.mt.)	Total FAR Area (Sq.mt.)
Ground Floor	A (SUSHILA DEVI)	58.16	58.16	58.16
First Floor	A (SUSHILA DEVI)	58.16	58.16	58.16
Terrace Floor	A (SUSHILA DEVI)	0.00	0.00	0.00
Total	A (SUSHILA DEVI)	116.32	116.32	116.32

Building USE/SUBUSE Details			
Building Name	Building Use	Building SubUse	Building Structure
A (SUSHILA DEVI)	Residential	Bungalow Dwelling / Non Apartment	Non-Highrise

FAR & Tenement Details (Table 4c-1)						
Building	No. of Same Bldg	Total Built Up Area (Sq.mt.)	Proposed FAR Area (Sq.mt.)	Total FAR Area (Sq.mt.)	Total Consumed Additional FAR Area (Sq.mt.)	Tenent (No.)
A (SUSHILA DEVI)	1	116.32	116.32	116.32	116.32	01
Grand Total	1	116.32	116.32	116.32	116.32	01

Building 'A' (SUSHILA DEVI)					
Floor Name	Total Built Up Area (Sq.mt.)	Proposed FAR Area (Sq.mt.)	Total FAR Area (Sq.mt.)	Total Consumed Additional FAR Area (Sq.mt.)	Tenent (No.)
Ground Floor	58.16	58.16	58.16	58.16	01
First Floor	58.16	58.16	58.16	58.16	01
Terrace Floor	0.00	0.00	0.00	0.00	00
Total	116.32	116.32	116.32	116.32	01
Total Number of Same Buildings	1	116.32	116.32	116.32	01
Total	116.32	116.32	116.32	116.32	01

SCHEDULE OF DOOR:				
BUILDING NAME	NAME	LENGTH	HEIGHT	NOS
A (SUSHILA DEVI)	D	0.76	2.10	03
A (SUSHILA DEVI)	D	0.92	2.10	02
A (SUSHILA DEVI)	D	1.07	2.10	03
A (SUSHILA DEVI)	D	1.22	2.10	01

SCHEDULE OF WINDOW/VENTILATION:				
BUILDING NAME	NAME	LENGTH	HEIGHT	NOS
A (SUSHILA DEVI)	W	0.61	1.20	02
A (SUSHILA DEVI)	W	1.22	1.20	09
A (SUSHILA DEVI)	W	1.83	1.20	02

Unit/BUA Table for Building 'A' (SUSHILA DEVI)						
FLOOR	Name	Unit/BUA Type	Unit/BUA Area	Carpert Area	No. of Rooms	No. of Tenement
GROUND FLOOR PLAN	SPLIT 1	FLAT	116.31	113.44	5	1
FIRST FLOOR PLAN	SPLIT 1	FLAT	0.00	0.00	6	0
Total	-	-	116.31	113.44	11	1

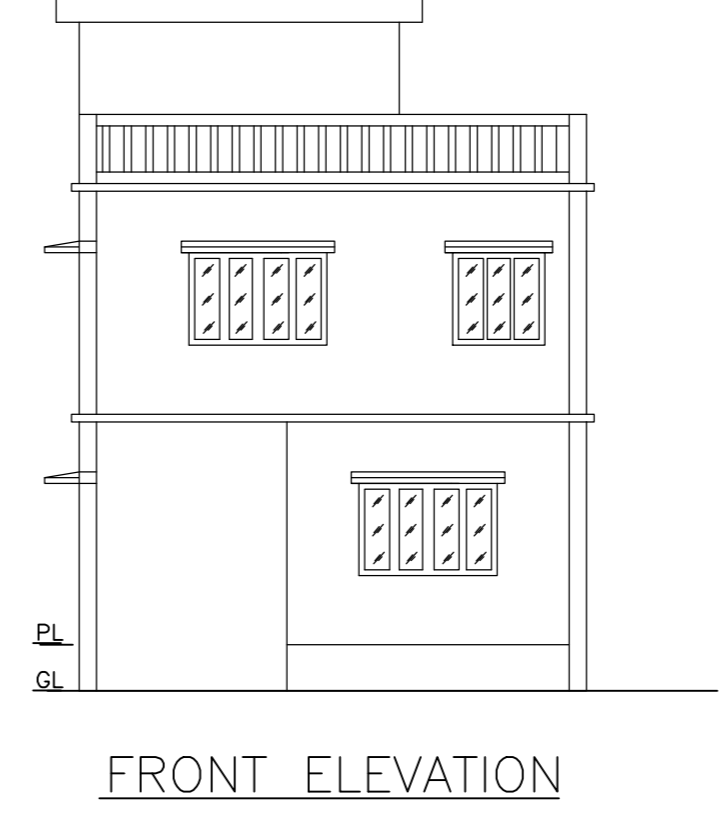
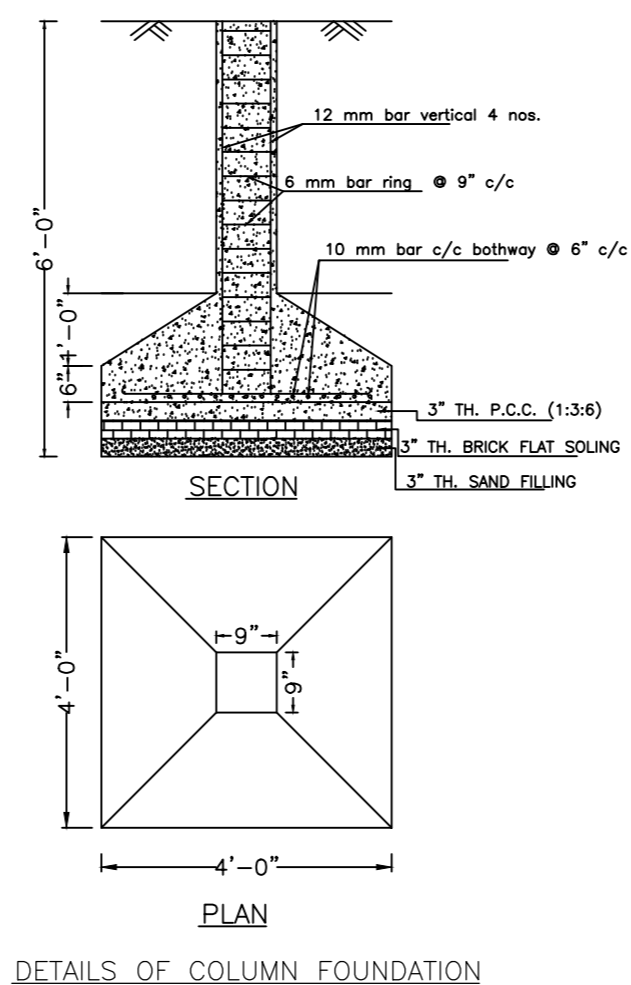
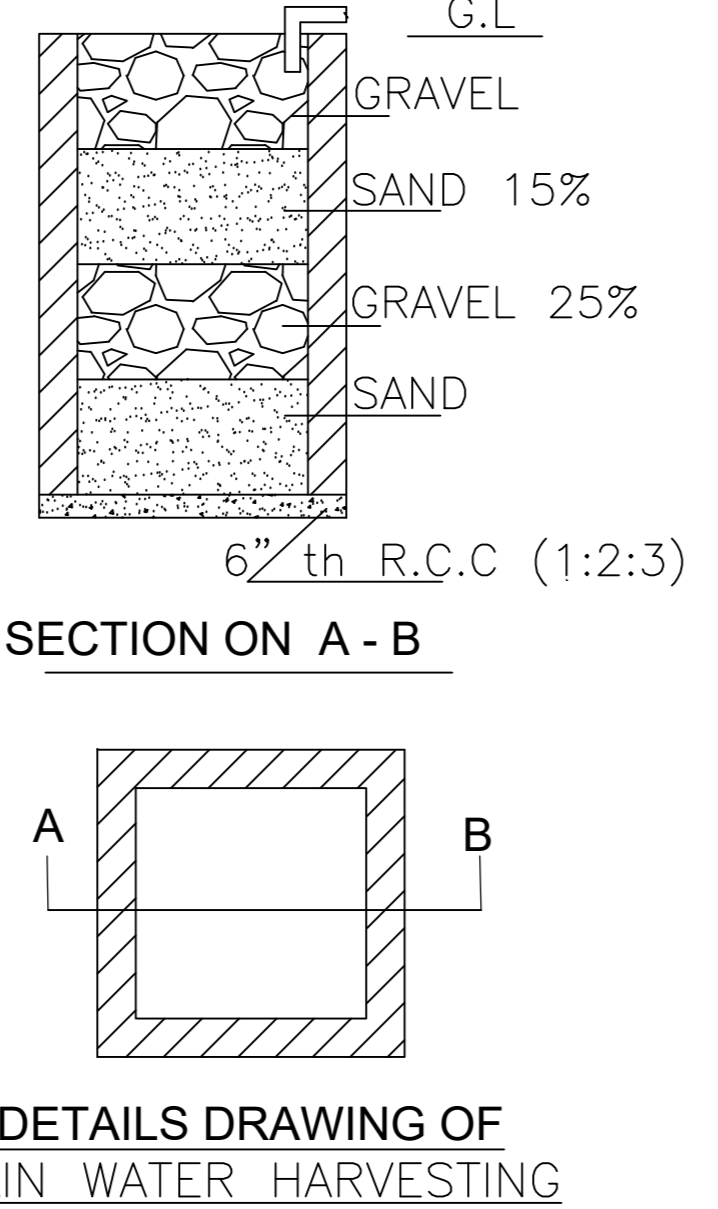
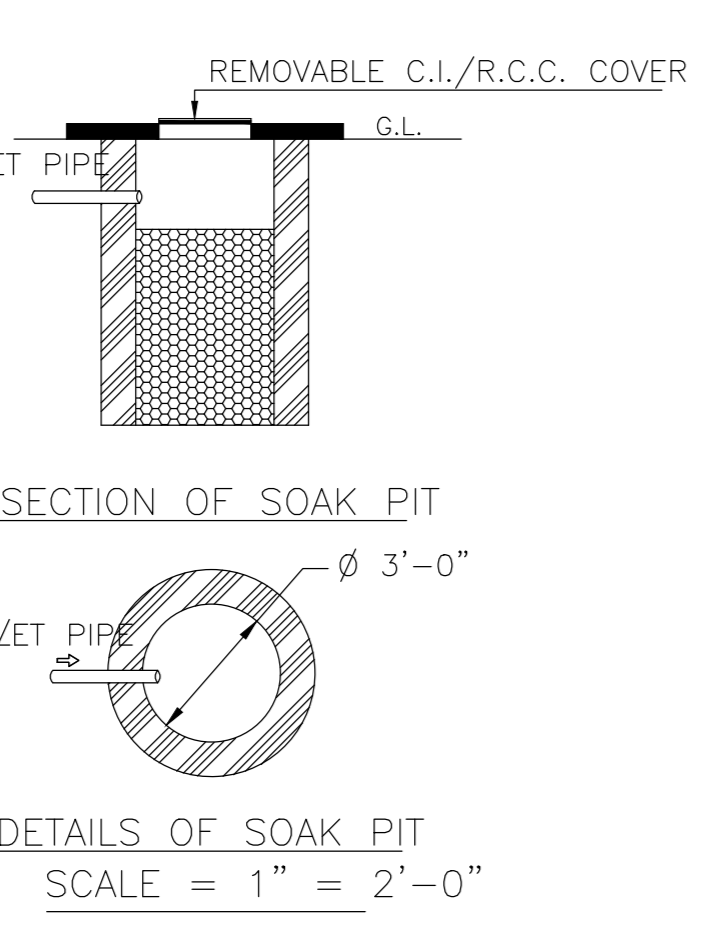
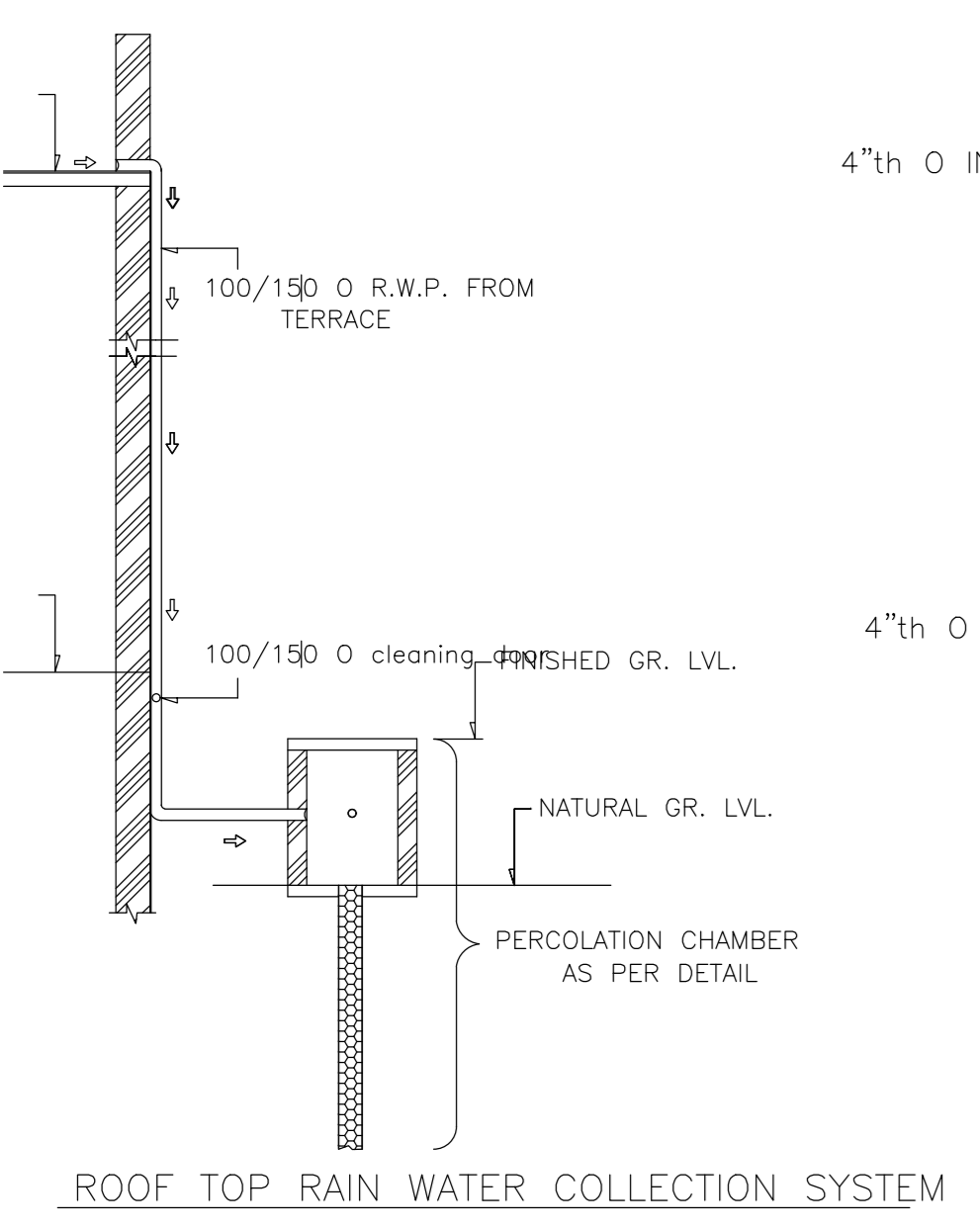

LTP NAME AND SIGNATURE	STRUCTURAL ENG'S NAME AND SIGNATURE	BUILDER NAME AND SIGNATURE	DIGITAL SIGNATURE
RAM PRATAP SINGH MADA/NRC/02/2019			