

**Proposal Basic Information**

Proposal File No.	MADA/PI/0184/2023
Owner Name	SMT SEEMA KUMARI
Khata No	59(OLD), 158(NEW)
Plot No	450(OLD), 1287(NEW)
Village Name	Tetulia
Use	Residential
SubUse	Bungalow/ Dwelling / Non Apartment

**AREA STATEMENT MINERAL AREA DEVELOPMENT AUTHORITY**

VERSION NO.: 1.0.66  
VERSION DATE: 16/10/2020

**PROJECT DETAIL:**

Region: JHARKHAND URBAN LOCAL BODIES	Plot Use: Residential
District: DHANBAD	Plot SubUse: Bungalow/ Dwelling / Non Apartment
Authority: MINERAL AREA DEVELOPMENT AUTHORITY	PlotNearbyReligiousStructure: NA
Inward No: MADA/PI/0184/2023	Plot/SubPlot No: 450(OLD), 1287(NEW)
Application Type: General Proposal	North: Road Width - 6.09 WIDE ROAD
Project Type: Building Permission	South: Plot No. - PART OF THIS PLOT
Nature of Development: New	East: Road Width - 9.14 WIDE ROAD
Location of Development Area: Old Area	West: Plot No. - PART OF THIS PLOT

**AREA DETAILS:**

AREA OF PLOT (Minimum)	(A)	SQ.MT.	215.77
NET AREA OF PLOT(Gross Plot Area - Deduction from Gross Plot area)	(A-Deductions)		215.77
Deduction for Balance Plot Area(from Gross Plot Area)			
Common Plot			25.36
Total			25.36
BALANCE AREA OF PLOT(Net Plot Area - Recreational/Amenity space)	(A-Deductions)		190.41
PLOT AREA FOR COVERAGE(Net Plot Area)	(A-Deductions)		215.77
Plot Area for FAR (Net Plot Area + Road Widening Area)	(A-Deductions)		215.77

**COVERAGE CHECK**

Permissible Coverage area ( 70.00 % )	151.04
Proposed Coverage Area ( 59.55 % )	128.48
Total Prop. Coverage Area ( 59.55 % )	128.48
Balance coverage area ( 10.46 % )	22.56

**FAR CHECK**

Perm. FAR Area ( 2.500 )	539.42
Total Perm. FAR area	539.42
Residential FAR	385.44
Proposed FAR Area	385.44
Total Proposed FAR Area	385.44
Consumed FAR (Factor)	1.79
Balance FAR Area	153.98

**BUILT UP AREA CHECK**

Total Proposed BuiltUp Area	385.44
-----------------------------	--------

**ARCHITECT (Regd)** Lalan Prasad Singh  
**ENGINEER (Regd)**  
**SUPERVISOR (Regd)**  
**OWNER (Regd)** SMT SEEMA KUMARI  
**DEVELOPMENT AUTHORITY** LOCAL BODY

FAR & Tenement Details (Table 4c-1)

Building	No. of Same Bldg	Total Built Up Area (Sq.mt.)	Proposed FAR Area (Sq.mt.) Res.	Total FAR Area (Sq.mt.)	Total Consumed Additional FAR Area (Sq.mt.)	Tnmt (No.)
AA (AA)	1	385.44	385.44	385.44	385.44	01
Grand Total:	1	385.44	385.44	385.44	385.44	01

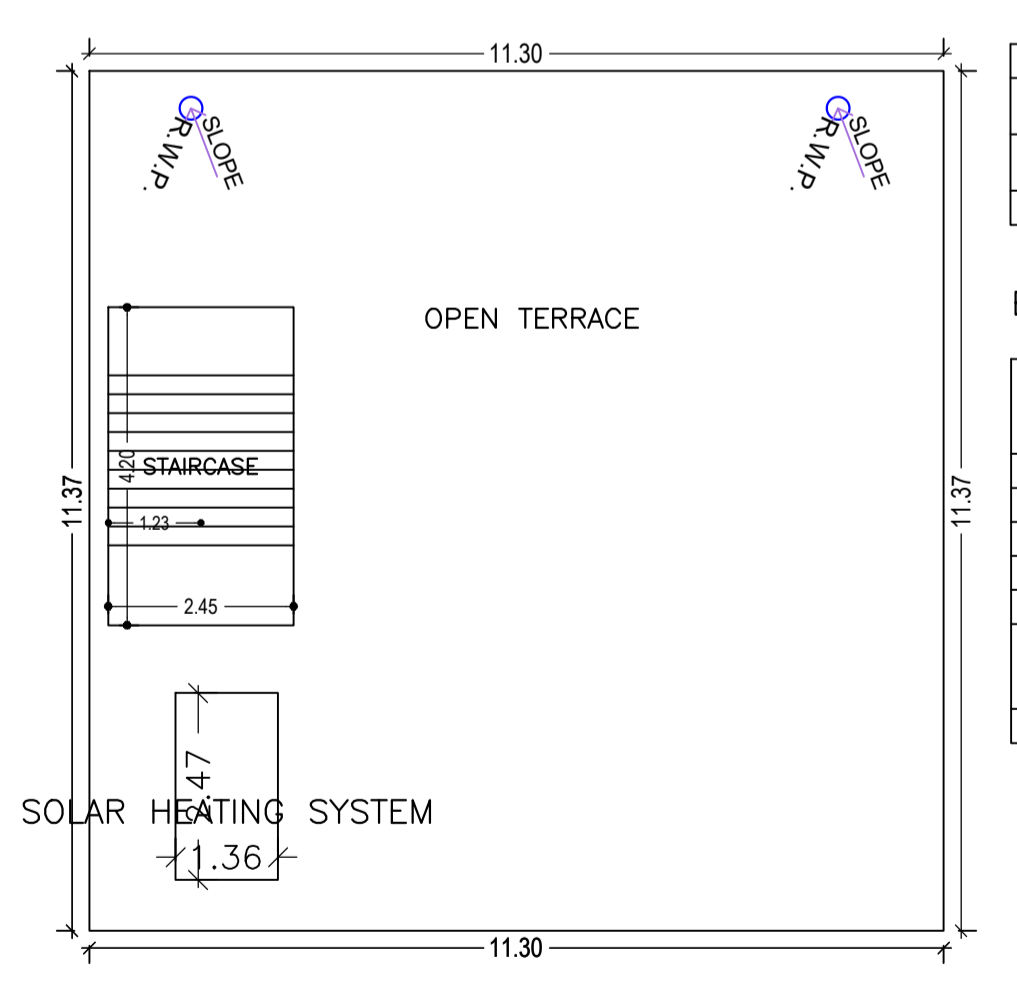
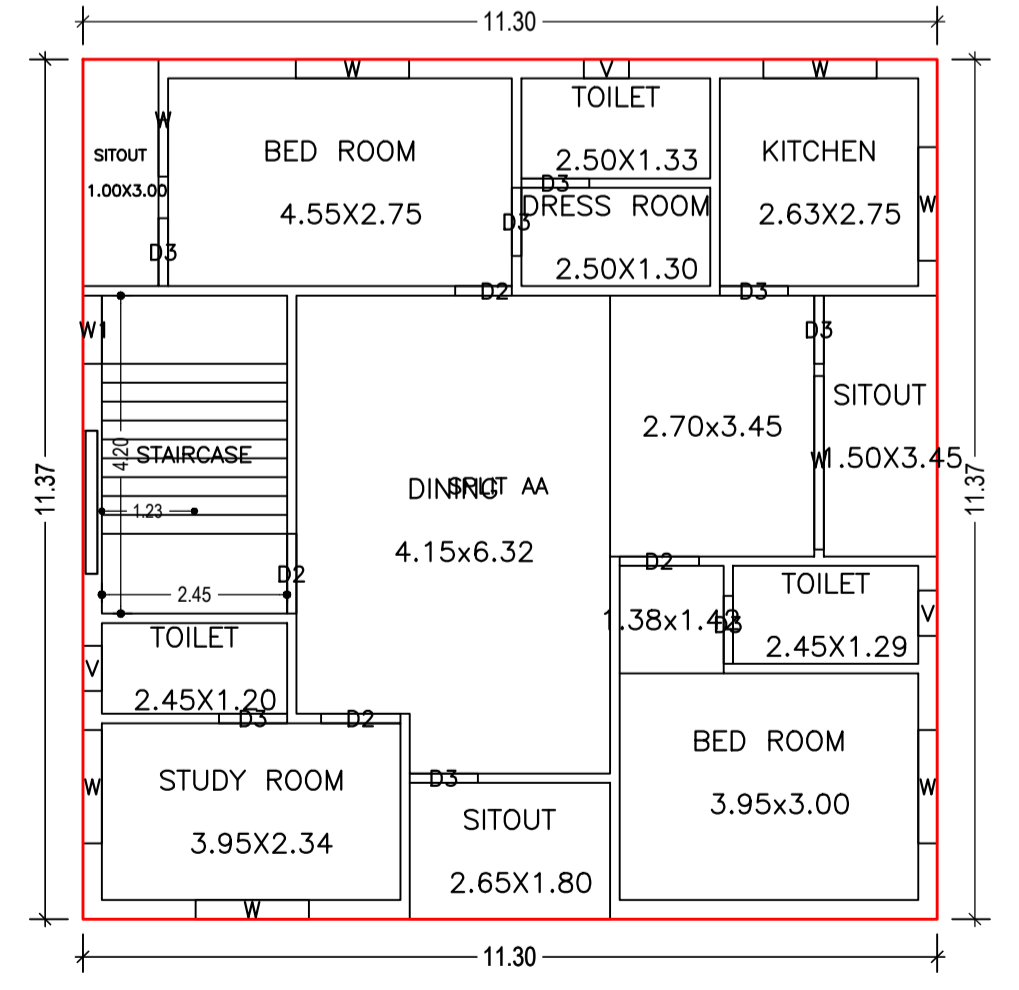
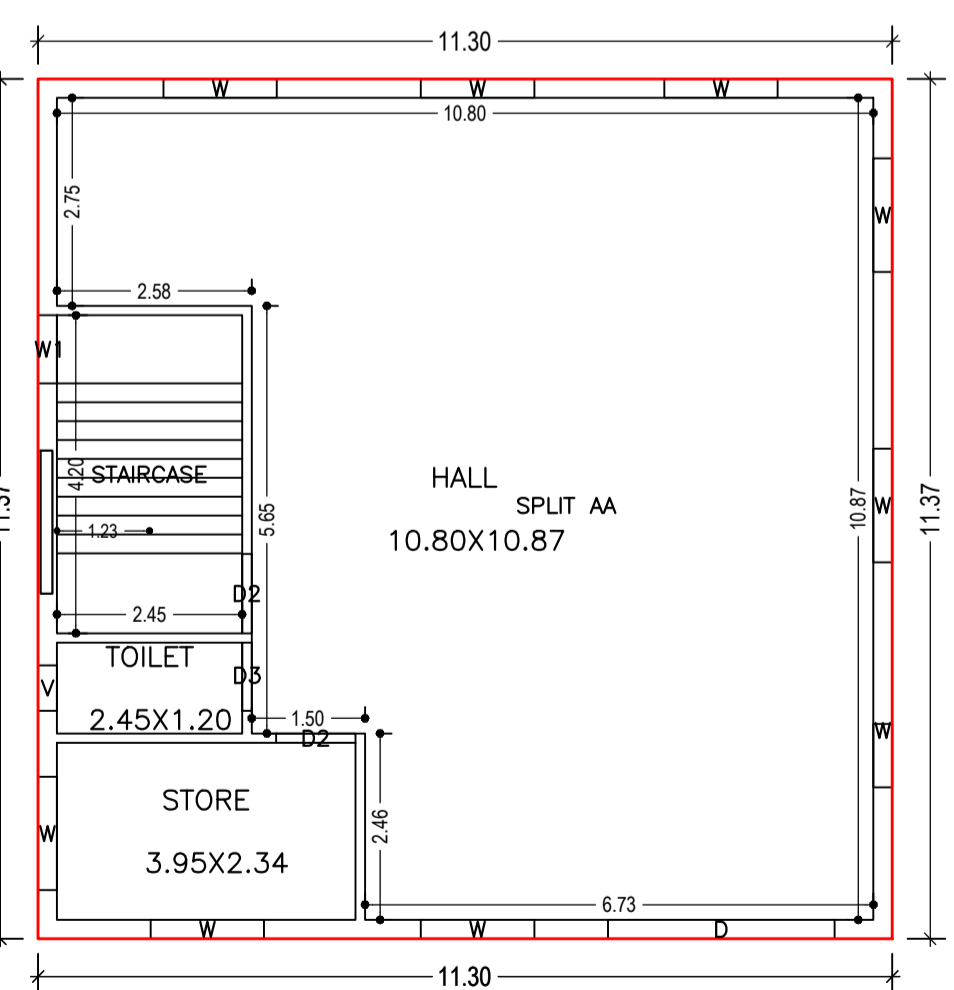
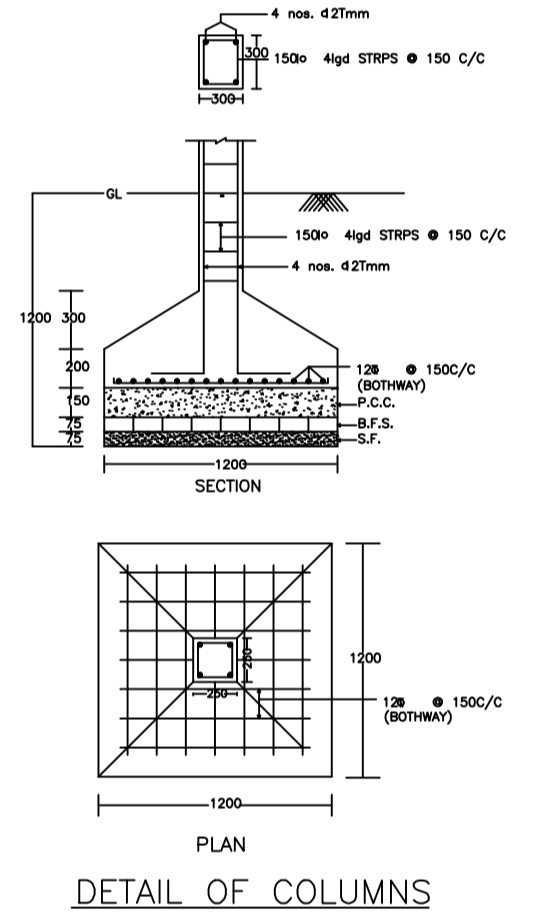
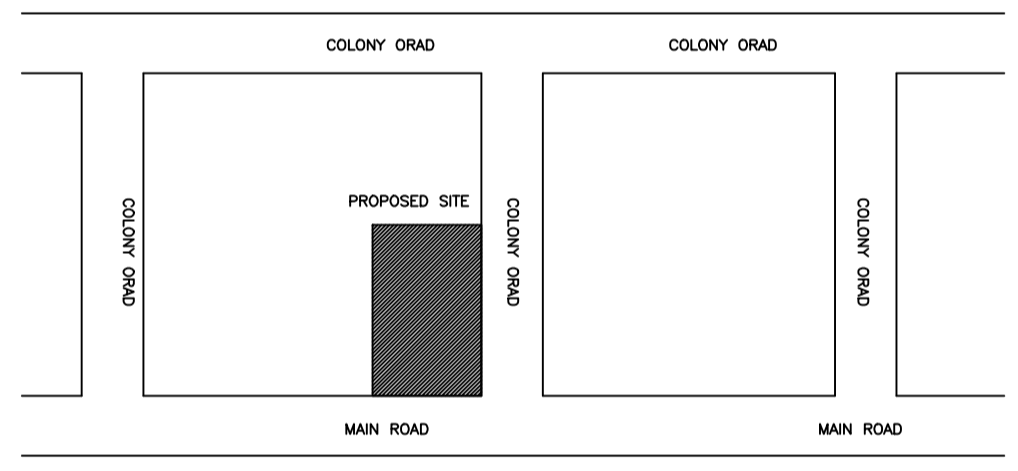

UnitBUA Table for Building :AA (AA)

FLOOR	Name	UnitBUA Type	UnitBUA Area	Carpet Area	No. of Rooms	No. of Tenement
GROUND FLOOR PLAN	SPLIT AA	FLAT	385.44	384.56	3	1
TYPICAL - 1, 2 FLOOR PLAN	SPLIT AA	FLAT	0.00	0.00	12	0
Total:			385.44	384.56	27	1

Building :AA (AA)

Floor Name	Total Built Up Area (Sq.mt.)	Proposed FAR Area (Sq.mt.) Res.	Total FAR Area (Sq.mt.)	Total Consumed Additional FAR Area (Sq.mt.)	Tnmt (No.)
Ground Floor	128.48	128.48	128.48	128.48	01
First Floor	128.48	128.48	128.48	128.48	00
Second Floor	128.48	128.48	128.48	128.48	00
Terrace Floor	0.00	0.00	0.00	0.00	00
Total :	385.44	385.44	385.44	385.44	01
Total Number of Same Buildings	1				
Total :	385.44	385.44	385.44	385.44	01

SCHEDULE OF DOOR:

BUILDING NAME	NAME	LENGTH	HEIGHT	NOS
AA (AA)	D2	0.75	2.10	02
AA (AA)	D3	0.90	2.10	17
AA (AA)	D2	1.05	2.10	08
AA (AA)	D	3.00	2.10	01

SCHEDULE OF WINDOW/VENTILATION:

BUILDING NAME	NAME	LENGTH	HEIGHT	NOS
AA (AA)	V	0.60	1.20	07
AA (AA)	W	0.75	1.20	02
AA (AA)	W	0.84	1.20	01
AA (AA)	W1	0.90	1.20	03
AA (AA)	W	1.50	1.20	20
AA (AA)	W	2.30	1.20	02

**COLOR INDEX**

PLOT BOUNDARY	Black
ABUTTING ROAD	Green
PROPOSED CONSTRUCTION	Red
COMMON PLOT	Yellow
ROAD WIDENING AREA	Blue
EXISTING (To be retained)	Orange
EXISTING (To be demolished)	Light Blue

**Buildingwise Floor FAR Details**

Floor Name	Building Name AA (AA)		Total	
	Proposed Built Up Area (Sq.mt.)	Proposed FAR Area (Sq.mt.)	Total Proposed Built Up Area (Sq.mt.)	Total FAR Area (Sq.mt.)
Ground Floor	128.48	128.48	128.48	128.48
First Floor	128.48	128.48	128.48	128.48
Second Floor	128.48	128.48	128.48	128.48
Terrace Floor	0.00	0.00	0.00	0.00
Total :	385.44	385.44	385.44	385.44

Building USE/SUBUSE Details

Building Name	Building Use	Building SubUse	Building Structure
AA (AA)	Residential	Bungalow/ Dwelling / Non Apartment	Non-Highrise

LTP NAME AND SIGNATURE	STRUCTURAL ENG'S NAME AND SIGNATURE	BUILDER NAME AND SIGNATURE	DIGITAL SIGNATURE
Lalan Prasad Singh MADA/ENG/0001/2020			