

Proposal Basic Information

Proposal File No.	MADA/BP/0197/2023
Owner Name	SRI. MITHILESH KUMAR RASTOGI
Khata No.	OLD KHATA NO-34, NEW KHATA NO-5
Plot No.	OLD PLOT NO-516, NEW PLOT NO-1457
Village Name	Jalgora
Use	Residential
SubUse	Bungalow Dwelling / Non Apartment

AREA STATEMENT MINERAL AUTHORITY	VERSION NO. 1.0.66	VERSION DATE: 16/10/2020
PROJECT DETAIL	Region: JHARKHAND URBAN LOCAL BODIES	
LOCAL BODIES	District: CHHALLIA	
Authority: MINERAL AREA DEVELOPMENT AUTHORITY	Project Use: Residential	
Project Name: MADANR/0197/2023	Plot SubUse: Bungalow Dwelling / Non Apartment	
Application Type: General Proposal	Plot/Plot No.: OLD PLOT NO-516, NEW PLOT NO-1457	
Project Type: Building Permission	North Plot No.: - SAME PLOT	
Nature of Development: New	South Plot No.: - SAME PLOT	
Location of Development Area: Old Area	East Road Width: 5.10	
Area	West Plot No.: - SAME PLOT	
AREA OF PLOT (Minimum)	(A)	SQ.MT. 138.97
NET AREA OF PLOT(Gross Plot Area - Deduction from Gross Plot Area)		138.97
Deduction for Balance Plot Area(from Gross Plot Area)		11.76
Common Plot		11.76
Balance Area of Plot(Net Plot Area - Recreational/Amenity space)	(A-Deductions)	122.21
Plot Area FOR COVERAGE(Net Plot Area)	(A-Deductions)	138.97
Plot Area for FAR (Net Plot Area + Road/Widening Area)	(A-Deductions)	138.97
COVERAGE CHECK		
Permissible Coverage area ( 70.00 % )		97.28
Proposed Coverage Area ( 58.96 % )		81.94
Total Prop. Coverage Area ( 58.96 % )		81.94
Balance coverage area ( 11.04 % )		15.34
FAR CHECK		
Perm. FAR Area ( 2.500 )		347.42
Total Perm. FAR area		347.42
Residential FAR		163.88
Proposed FAR Area		163.88
Total Proposed FAR Area		163.88
Consumed FAR (Factor)		1.18
Balance FAR Area		163.84
BUILT UP AREA CHECK		
Goal Proposed BuiltUp Area		163.88
ARCHITECT (Regd)	RAM PRATAP SINGH	
ENGINEER (Regd)		
SUPERVISOR (Regd)		
OWNER (Regd)	SRI. MITHILESH KUMAR RASTOGI	
DEVELOPMENT AUTHORITY	LOCAL BODY	

COLOR INDEX	
Plot Boundary	Black
Abutting Road	Red
Proposed Construction	Green
Common Plot	Yellow
Road Widening Area	Blue
Existing (To be retained)	Orange
Existing (To be demolished)	Purple

Buildingwise Floor FAR Details				
Floor Name	Building Name	Proposed Built Up Area (Sq.mt.)	Proposed FAR Area (Sq.mt.)	Total FAR Area (Sq.mt.)
Ground Floor	A (MITHILESH KUMAR RASTOGI)	81.94	81.94	81.94
First Floor	A (MITHILESH KUMAR RASTOGI)	0.00	0.00	0.00
Terrace Floor	A (MITHILESH KUMAR RASTOGI)	0.00	0.00	0.00
Total	A (MITHILESH KUMAR RASTOGI)	81.94	81.94	81.94

Building USE/SUBUSE Details				
Building Name	Building Use	Building SubUse	Building Structure	
A (MITHILESH KUMAR RASTOGI)	Residential	Bungalow Dwelling / Non Apartment	Non-Highrise	

FAR & Tenement Details (Table 4c-1)						
Building	No. of Same Bldg	Total Built Up Area (Sq.mt.)	Proposed FAR Area (Sq.mt.)	Total FAR Area (Sq.mt.)	Total Consumed Additional FAR Area (Sq.mt.)	Tenent (No.)
A (MITHILESH KUMAR RASTOGI)	1	81.94	81.94	81.94	163.88	01
Grand Total	1	81.94	81.94	81.94	163.88	01

Building :A (MITHILESH KUMAR RASTOGI)					
Floor Name	Total Built Up Area (Sq.mt.)	Proposed FAR Area (Sq.mt.)	Total FAR Area (Sq.mt.)	Total Consumed Additional FAR Area (Sq.mt.)	Tenent (No.)
Ground Floor	81.94	81.94	81.94	81.94	01
First Floor	81.94	81.94	81.94	81.94	00
Terrace Floor	0.00	0.00	0.00	0.00	00
Total	163.88	163.88	163.88	163.88	01

SCHEDULE OF DOOR:				
BUILDING NAME	NAME	LENGTH	HEIGHT	NOS
A (MITHILESH KUMAR RASTOGI)	D	0.76	2.10	02
A (MITHILESH KUMAR RASTOGI)	D	0.79	2.10	01
A (MITHILESH KUMAR RASTOGI)	D	0.91	2.10	01
A (MITHILESH KUMAR RASTOGI)	D	0.93	2.10	01
A (MITHILESH KUMAR RASTOGI)	D	0.97	2.10	01
A (MITHILESH KUMAR RASTOGI)	D	1.00	2.10	01
A (MITHILESH KUMAR RASTOGI)	D	1.07	2.10	04
A (MITHILESH KUMAR RASTOGI)	D	1.52	2.10	01

SCHEDULE OF WINDOW/VENTILATION:				
BUILDING NAME	NAME	LENGTH	HEIGHT	NOS
A (MITHILESH KUMAR RASTOGI)	W	0.84	1.20	03
A (MITHILESH KUMAR RASTOGI)	W	1.22	1.20	01
A (MITHILESH KUMAR RASTOGI)	W	1.52	1.20	10
A (MITHILESH KUMAR RASTOGI)	W	2.55	1.20	02

UnIRBUA Table for Building :A (MITHILESH KUMAR RASTOGI)						
FLOOR	Name	UnIRBUA Type	UnIRBUA Area	Carpet Area	No. of Rooms	No. of Tenement
GROUND FLOOR PLAN	SPLIT 1	FLAT	163.88	163.22	5	1
FIRST FLOOR PLAN	SPLIT 1	FLAT	0.00	0.00	7	0
Total	-	-	163.88	163.22	12	1

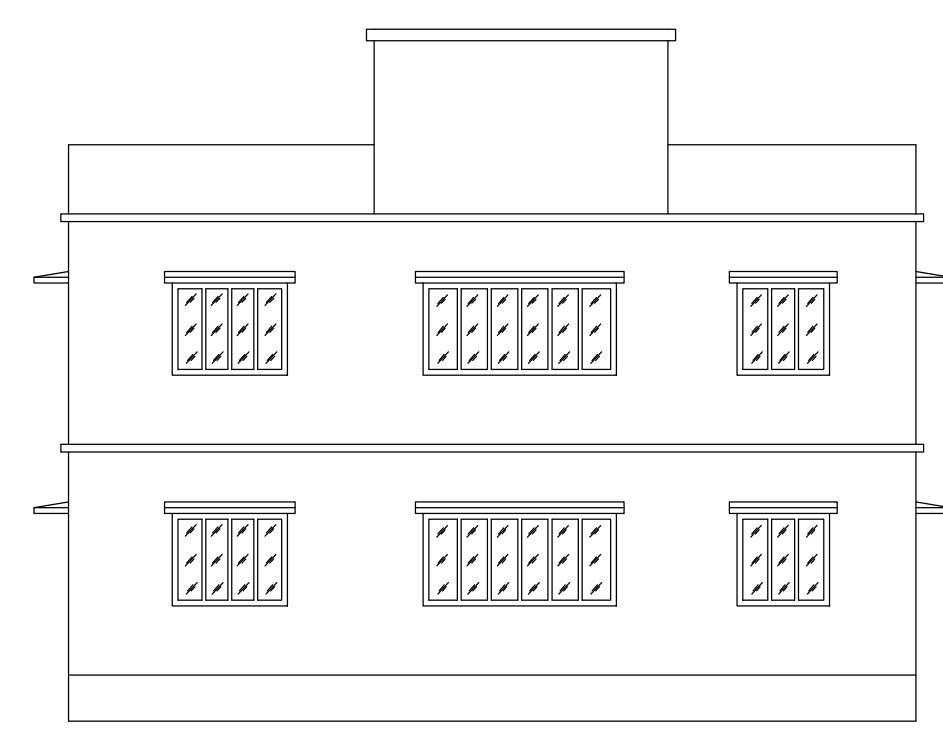
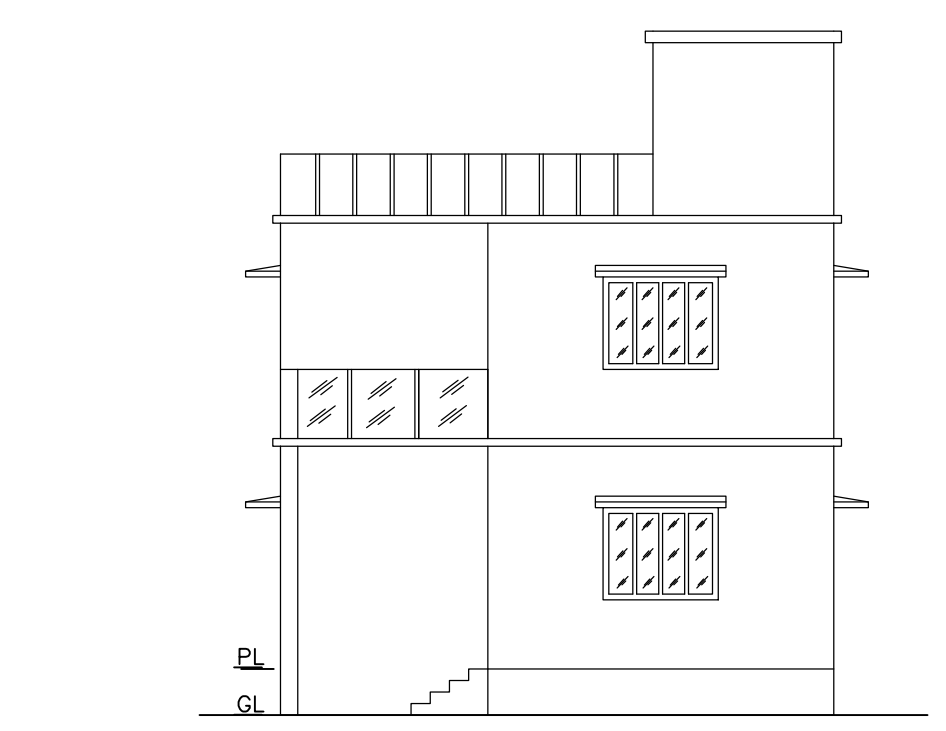
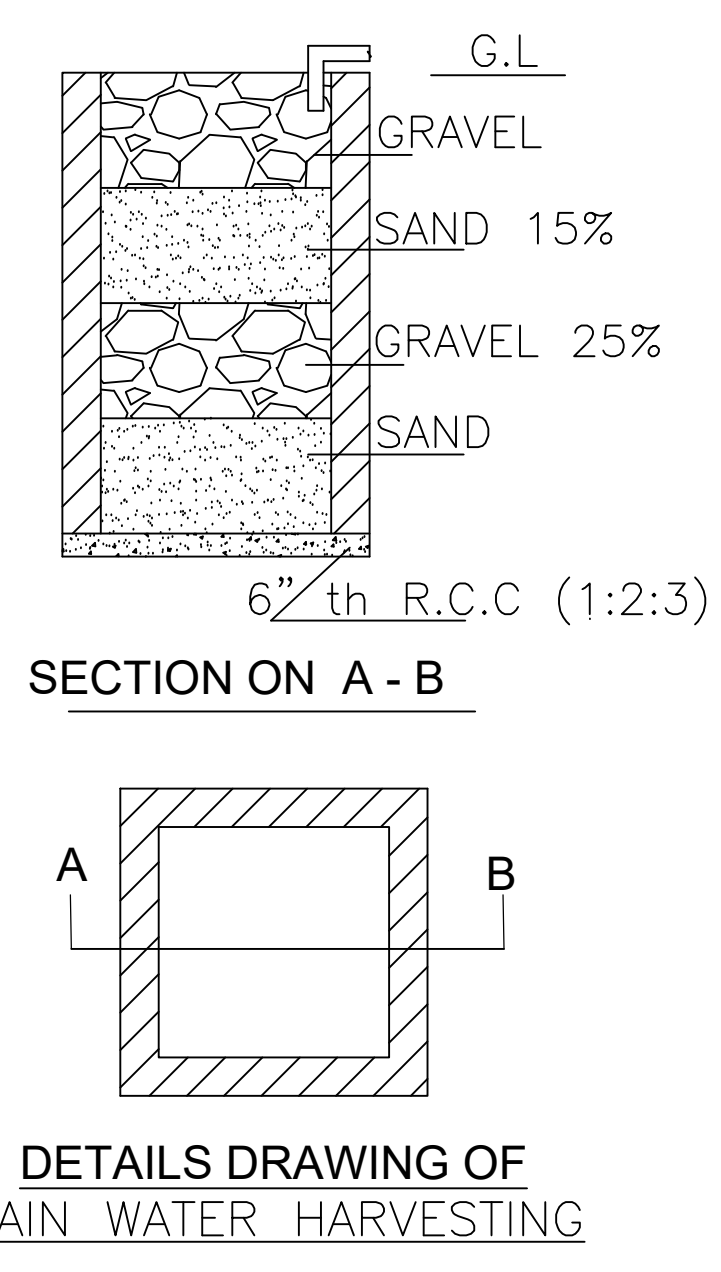
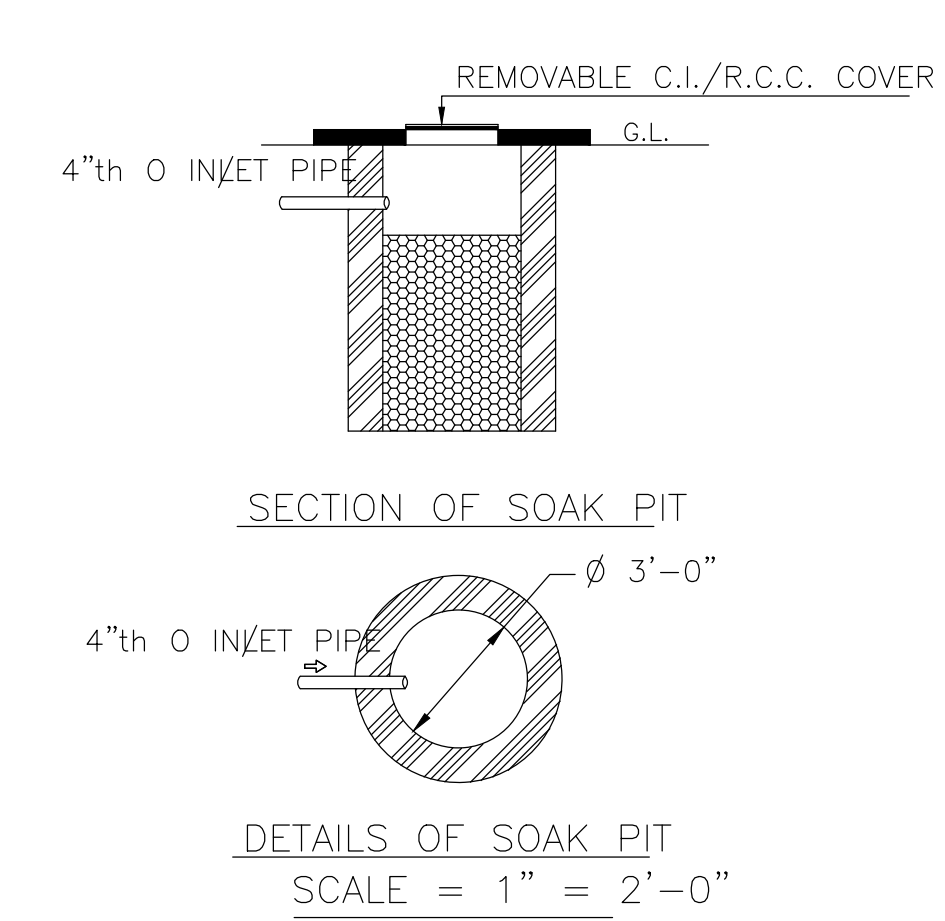
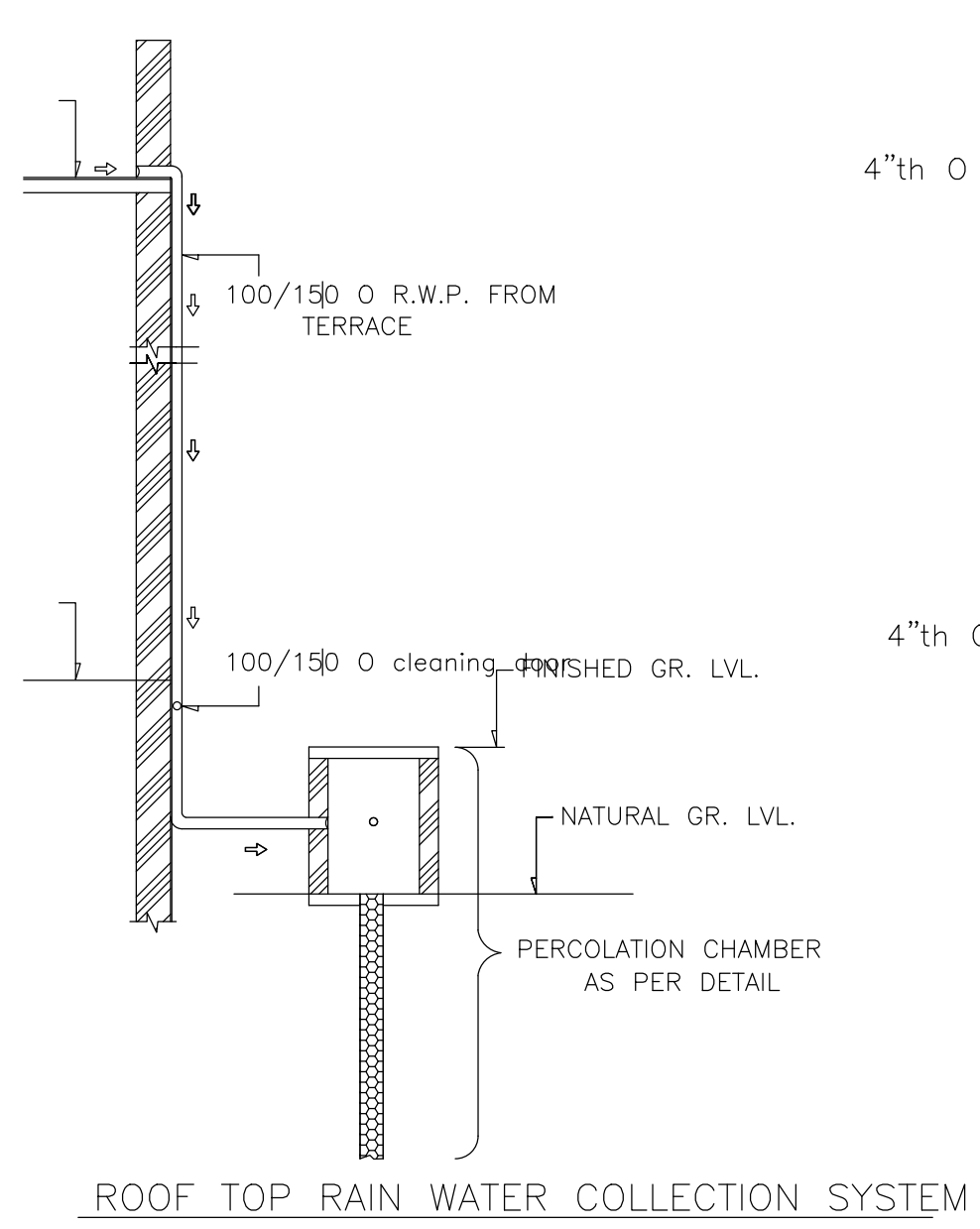
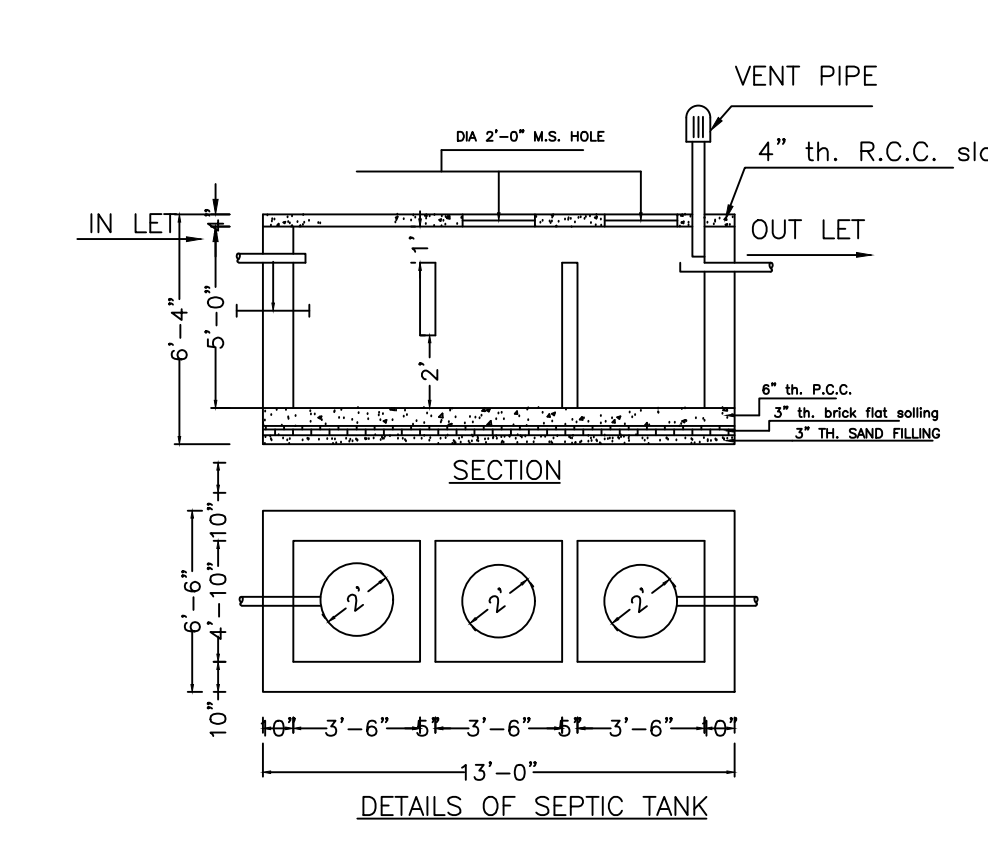
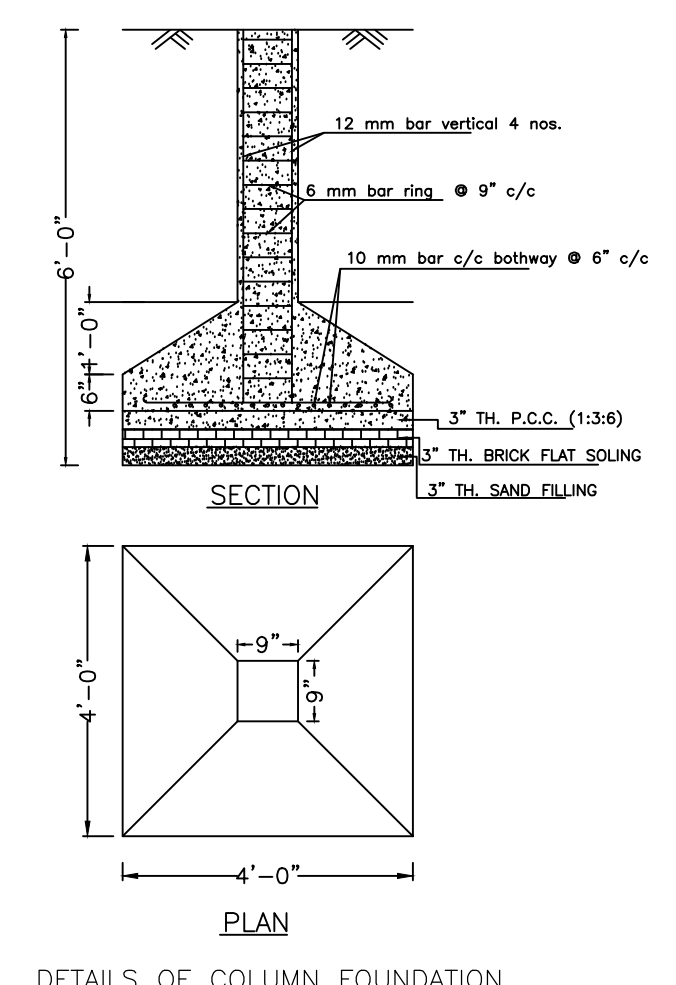
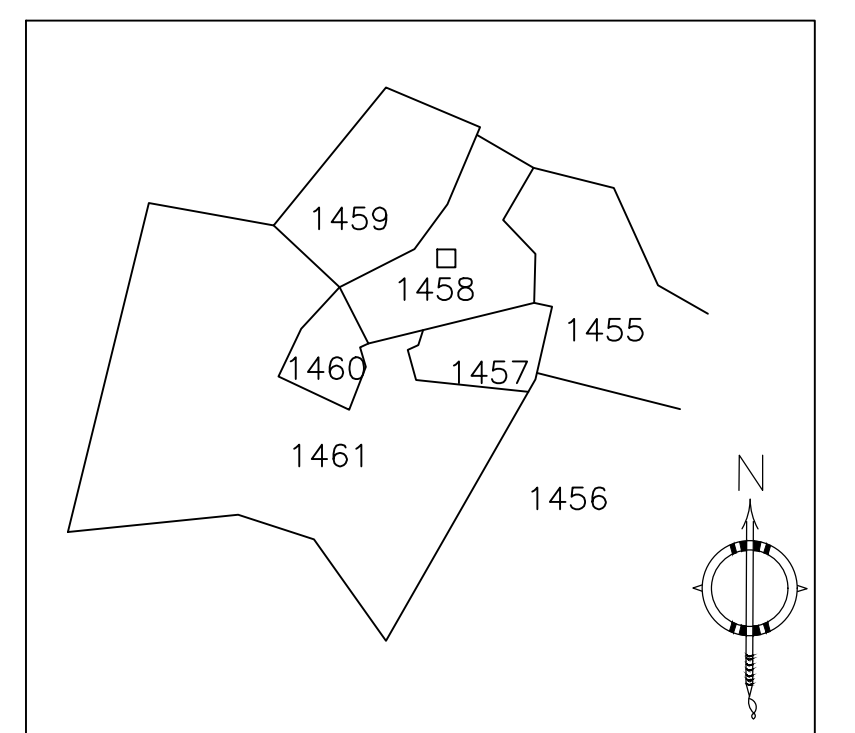
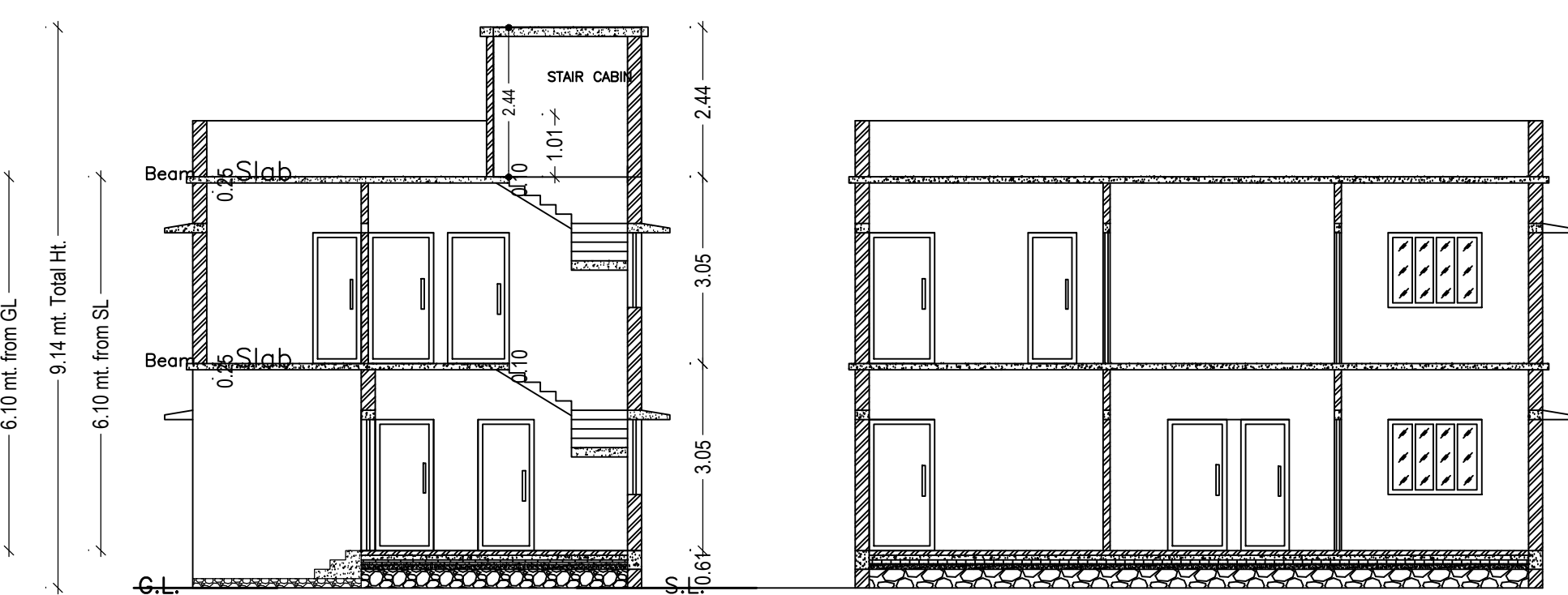
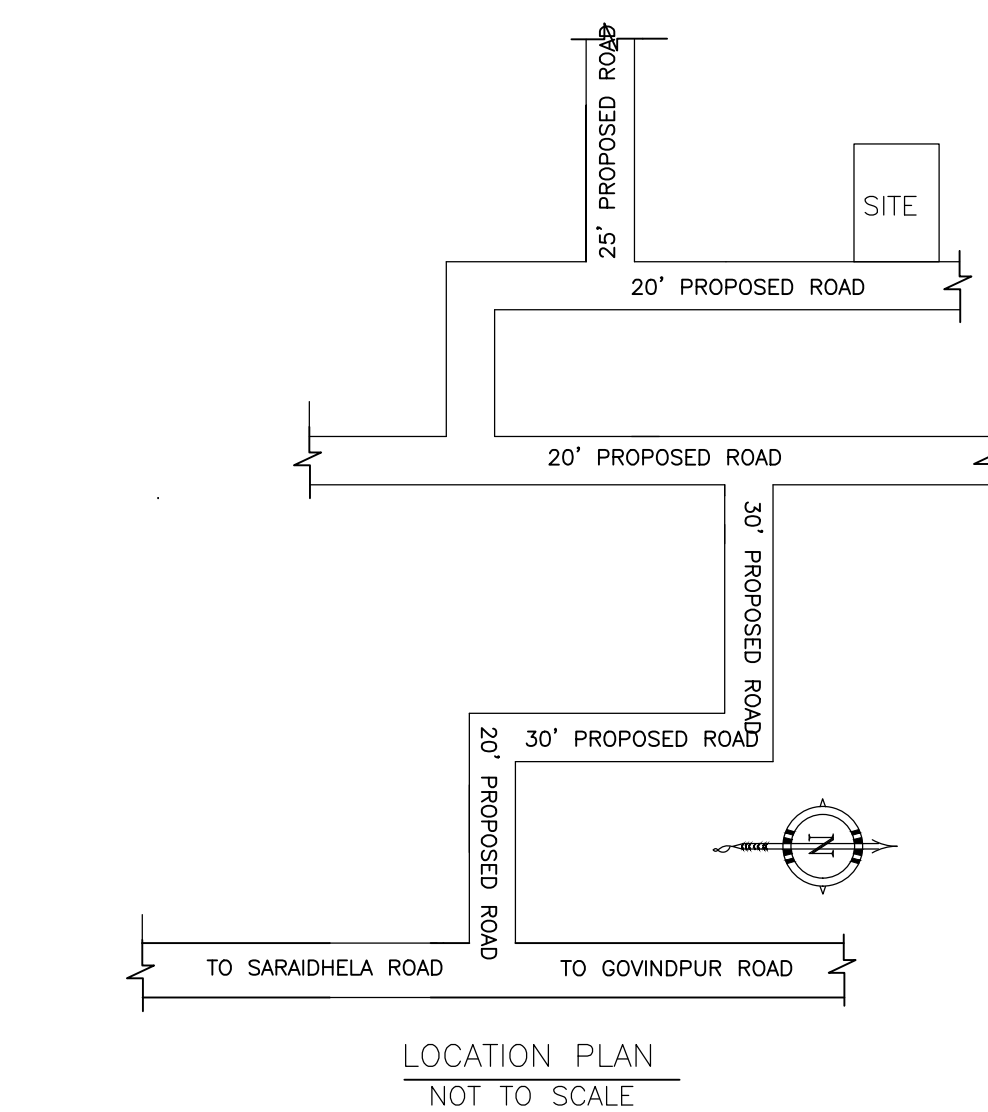
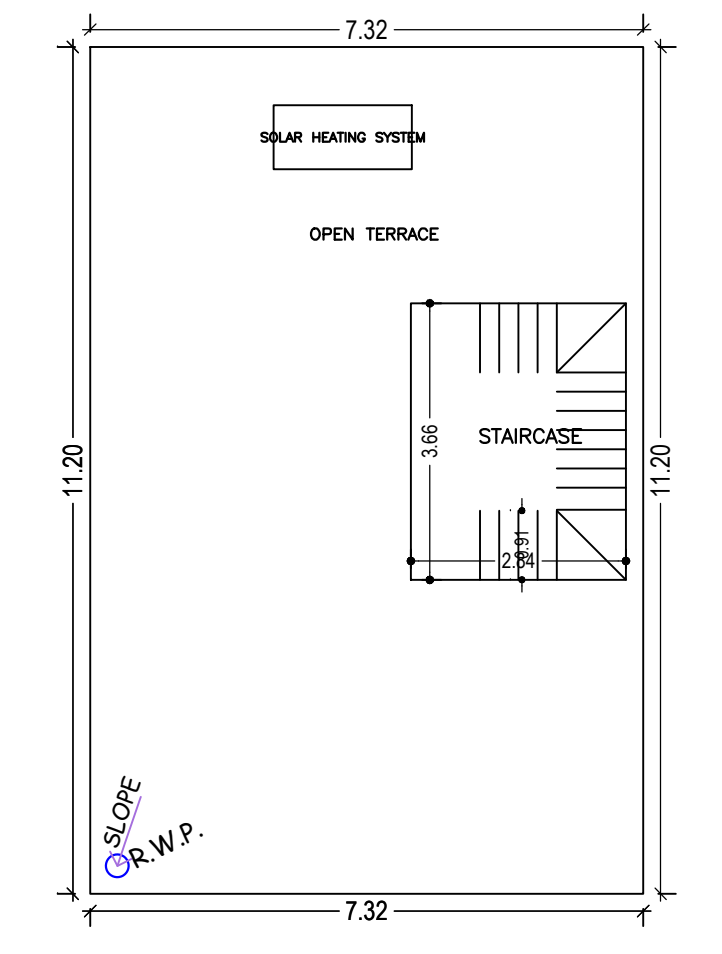
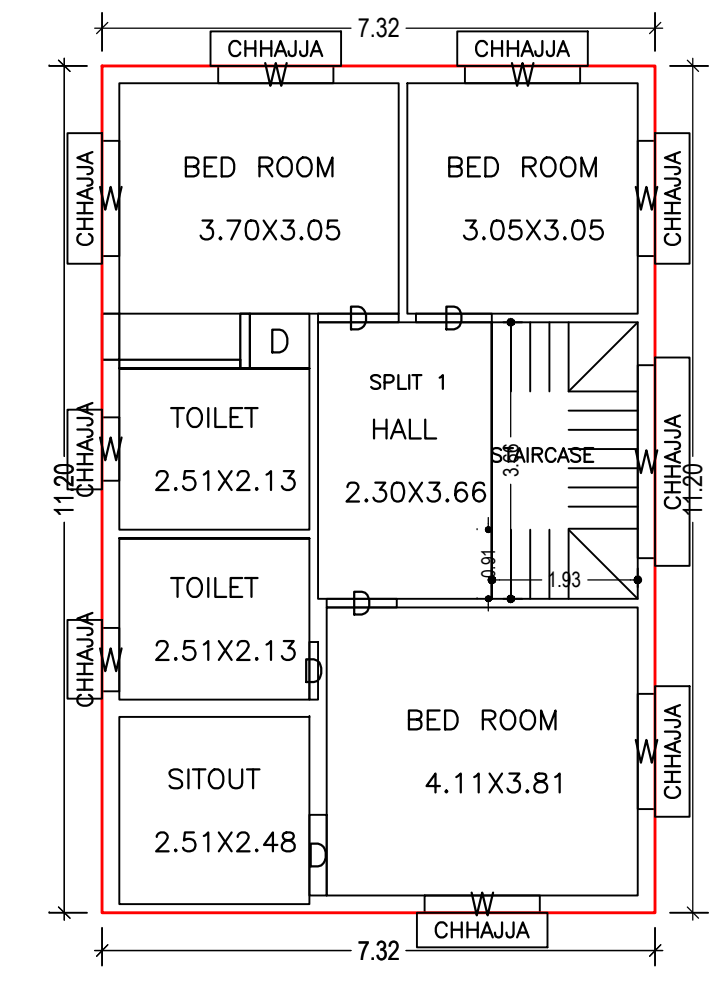
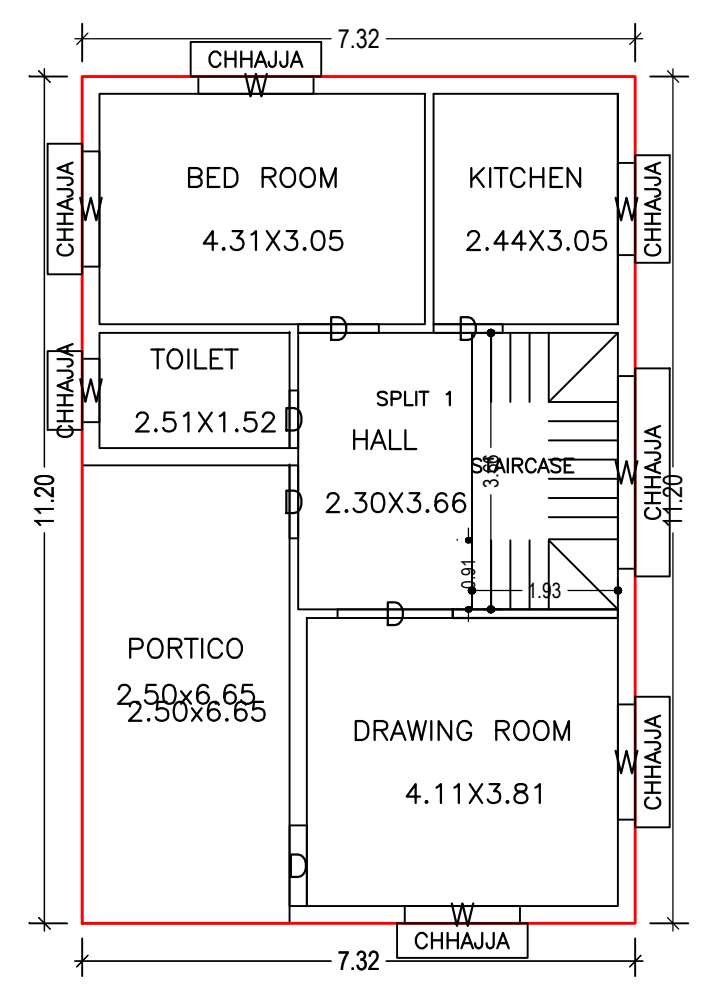
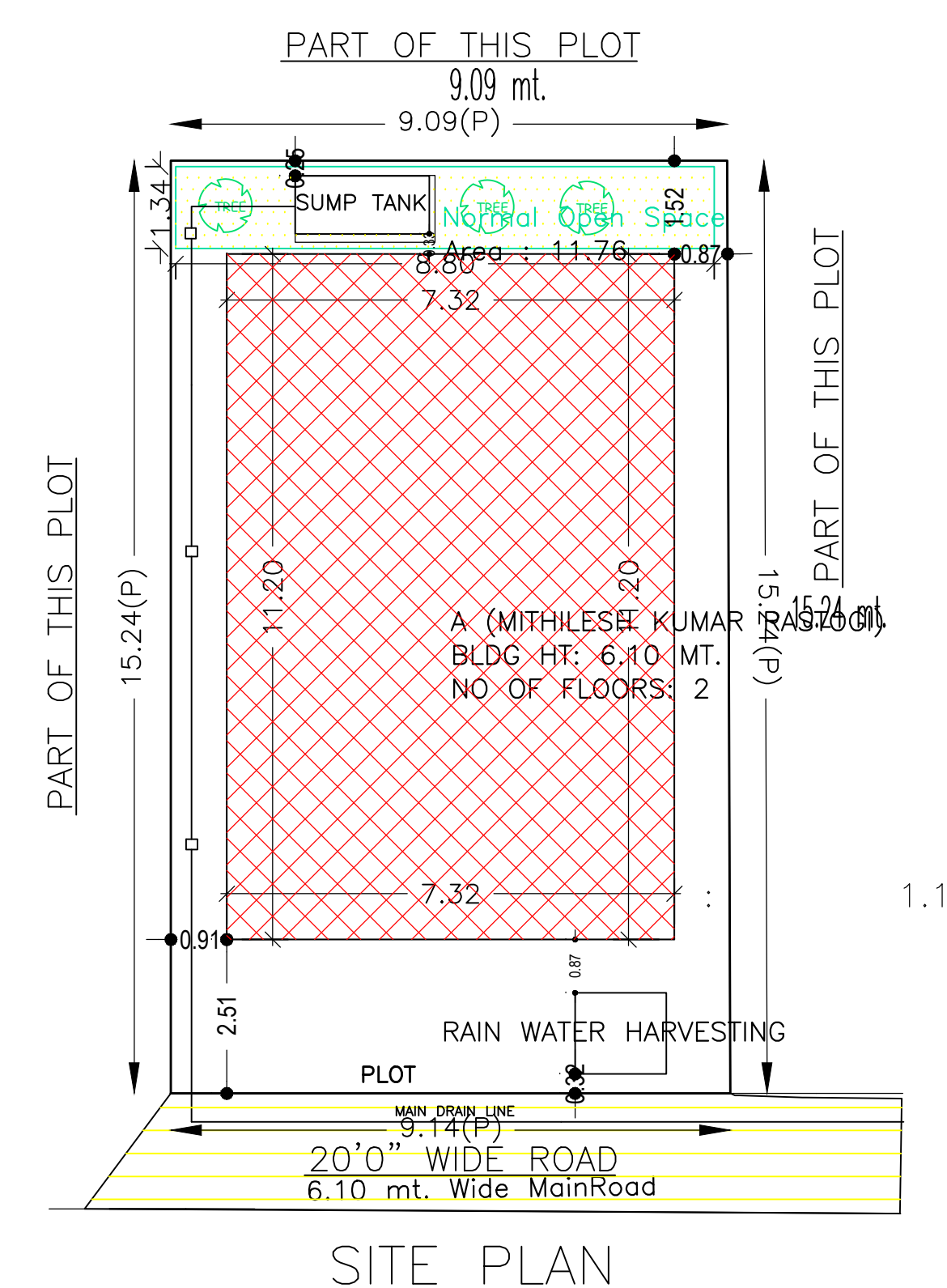

LTP NAME AND SIGNATURE: RAM PRATAP SINGH, MADA/NRC/0024/2019