

Project Title : Smt. NIMMI WALIA

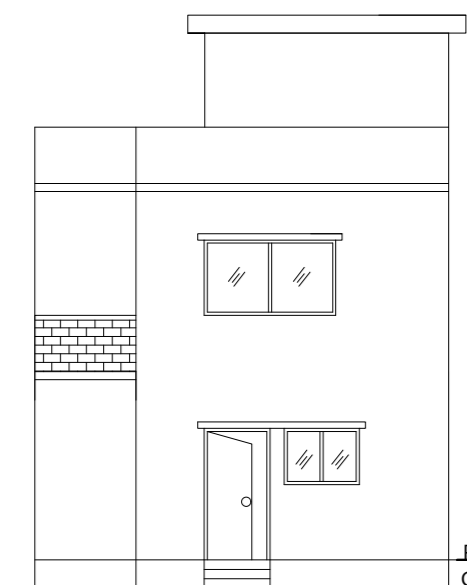

FRONT ELEVATION

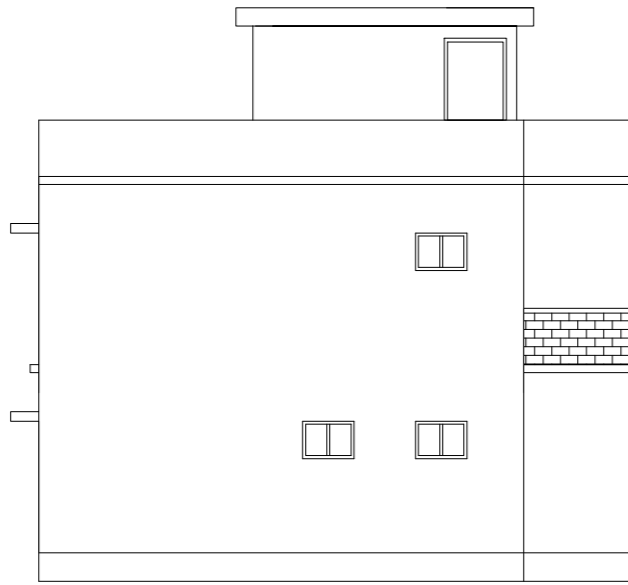

LEFT SIDE ELEVATION

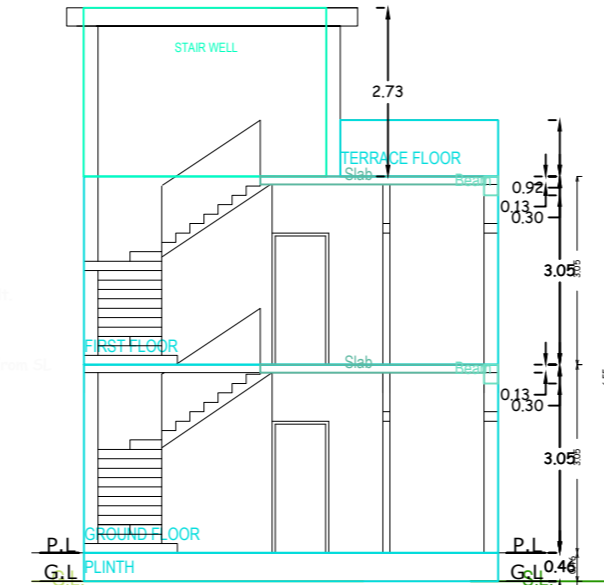

SECTION AT X-X

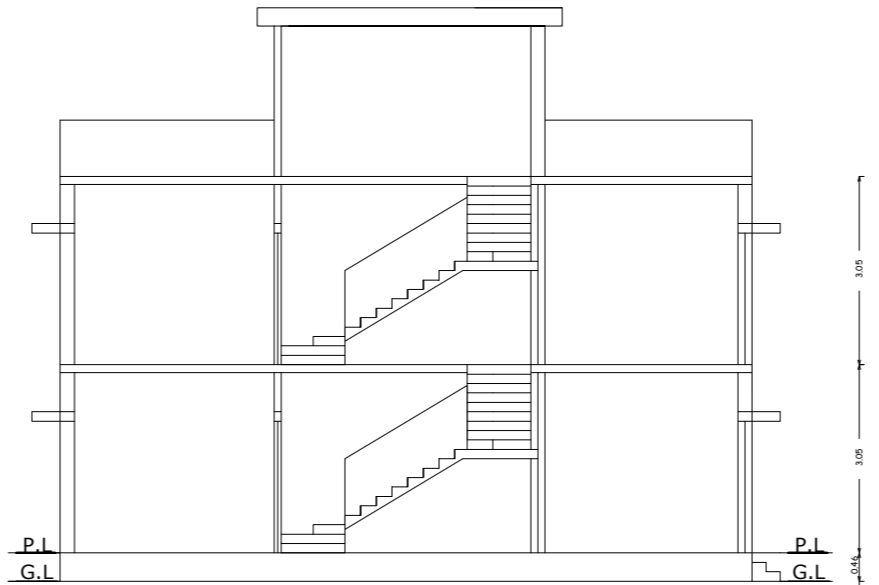

SECTION AT Y-Y

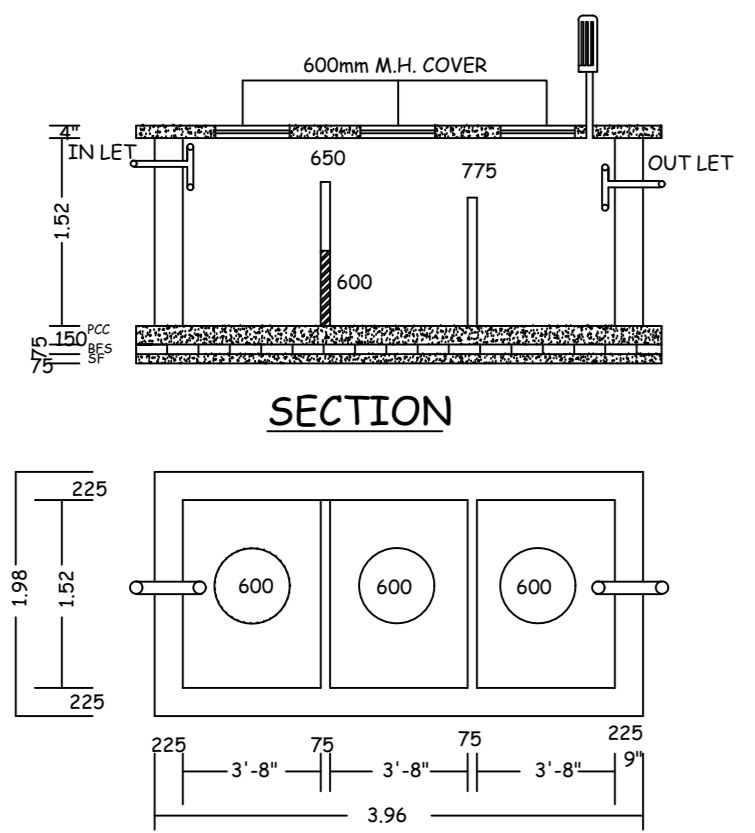

SECTION

PLAN OF SEPTIC TANK  
(SCALE:-1:25)

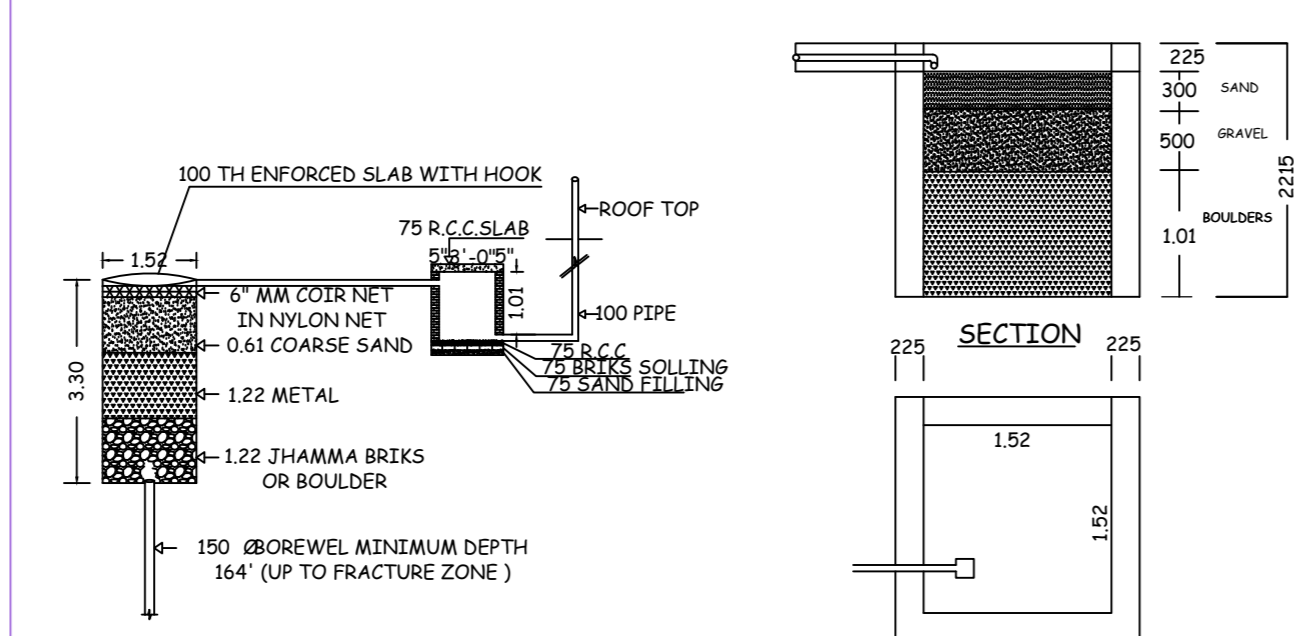

DETAIL OF GROUND WATER RECHARGING PIT WITH STILT TANK  
NOT TO SCALE

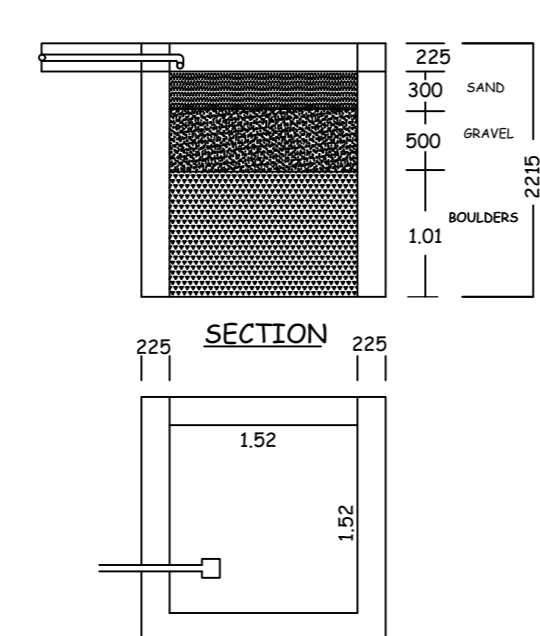

PLAN OF RAIN WATER HARVESTING  
(SCALE:-1:25)

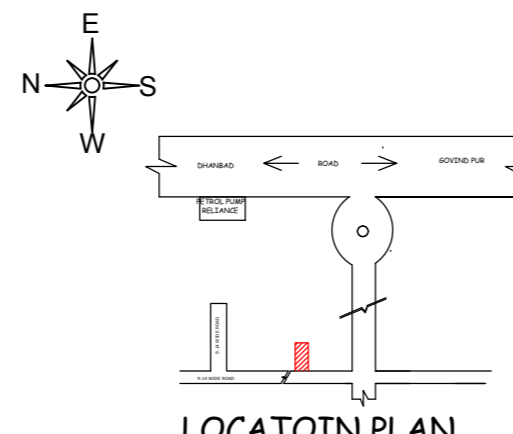

LOCATION PLAN  
NOT TO SCALE

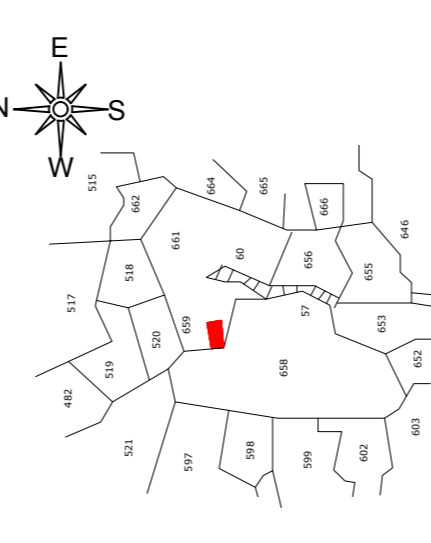

KEY PLAN  
NOT TO SCALE

SPECIFICATIONS

- FOUNDATION----- CEMENT CONCRETE (1:3:6)
- BRICK WORK IN FOUNDATION & SUPERSTRUCTURE
- FIRST CLASS BRICK WORK IN CEMENT MORTAR (1:6)
- D.P.C.-----25mm D.P.C. IN CEMENT CONCRETE(1:2:4)
- FLOOR-----25mm L.P.S OVER 3" P.C.C.
- LINTEL-----150mm THICK R.C.C LINTEL (1:1 1/2:4)
- ROOF-----125mm THICK R.C.C ROOF (1:1 1/2:4)
- STAIR-----RISE - 150mm , TREAD - 230mm
- DOOR-----D - 1.06X2.13, D1 - 0.91X2.13, D2 - 0.76X2.13
- WINDOWS-----W - 1.83X1.22
- VENTILATION-----V - 0.61X0.61
- COLLAPSIBLE GATE-----C.G - 1.22X2.13
- JALI-----J - 0.91

NOTES

- AREA OF LAND -----116.17 Sqm.
- GROUND FLOOR PLINTH AREA -----68.40 Sqm.
- GROUND FLOOR COVERED AREA -----73.97 Sqm.
- FIRST FLOOR COVERED AREA -----72.39 Sqm.
- TOTAL COVERED AREA -----146.36 Sqm
- % OF PLINTH AREA -----58.87
- F.A.R -----125

TITLE OF DRAWING

PLAN OF THE PROPOSED RESIDENTIAL BUILDING OF SMT. NIMMI WALIA  
W/O SRI VIJAY WALIA ON PART OF C.S PLOT NO - 579 (OLD),659 (NEW), UNDER  
KHATA NO- 57 (OLD), 146 (NEW), IN NOUZA - AMAGHATA ,NO - 170 , IN THE  
DISTRICT OF DHANBAD , (JHARKHAND).

SIGNATURE OF OWNER

SIGNATURE OF ENGINEER  
SCALE :- 1:100

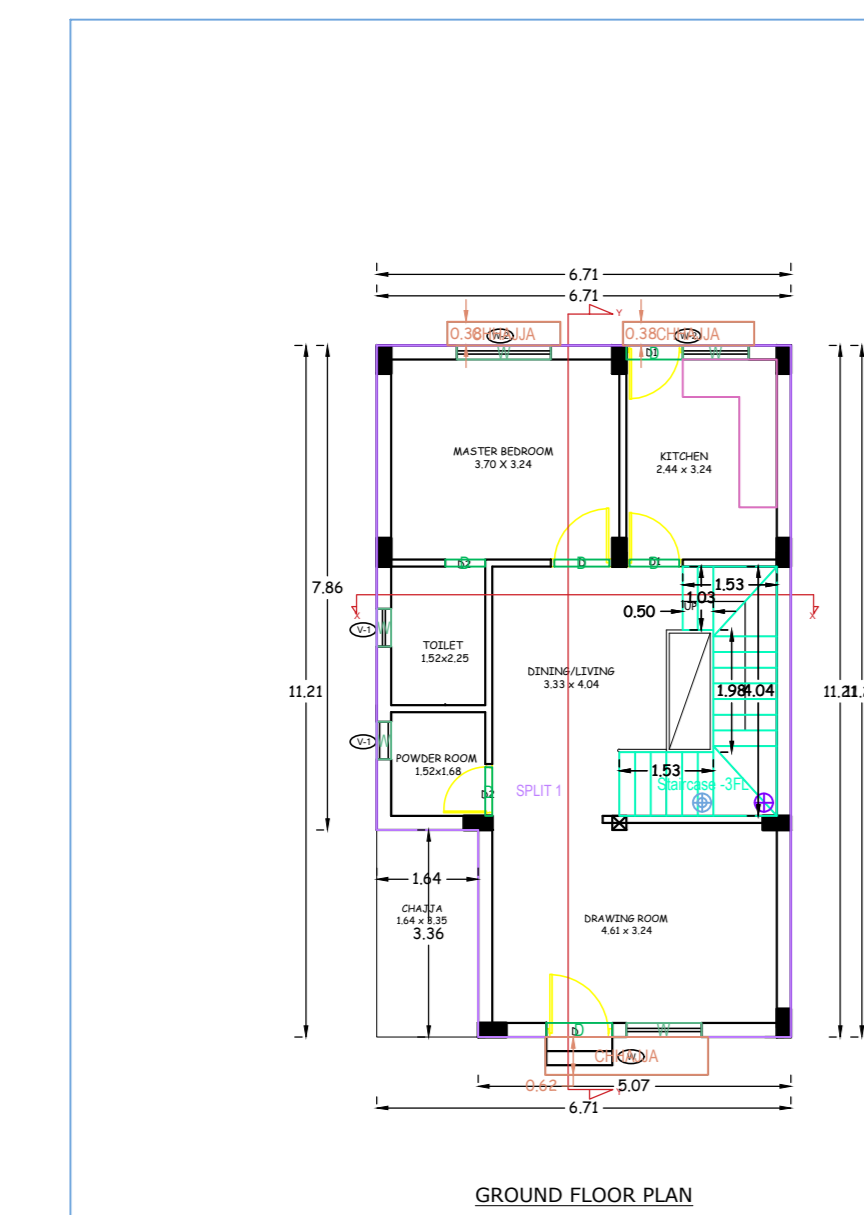

GROUND FLOOR PLAN

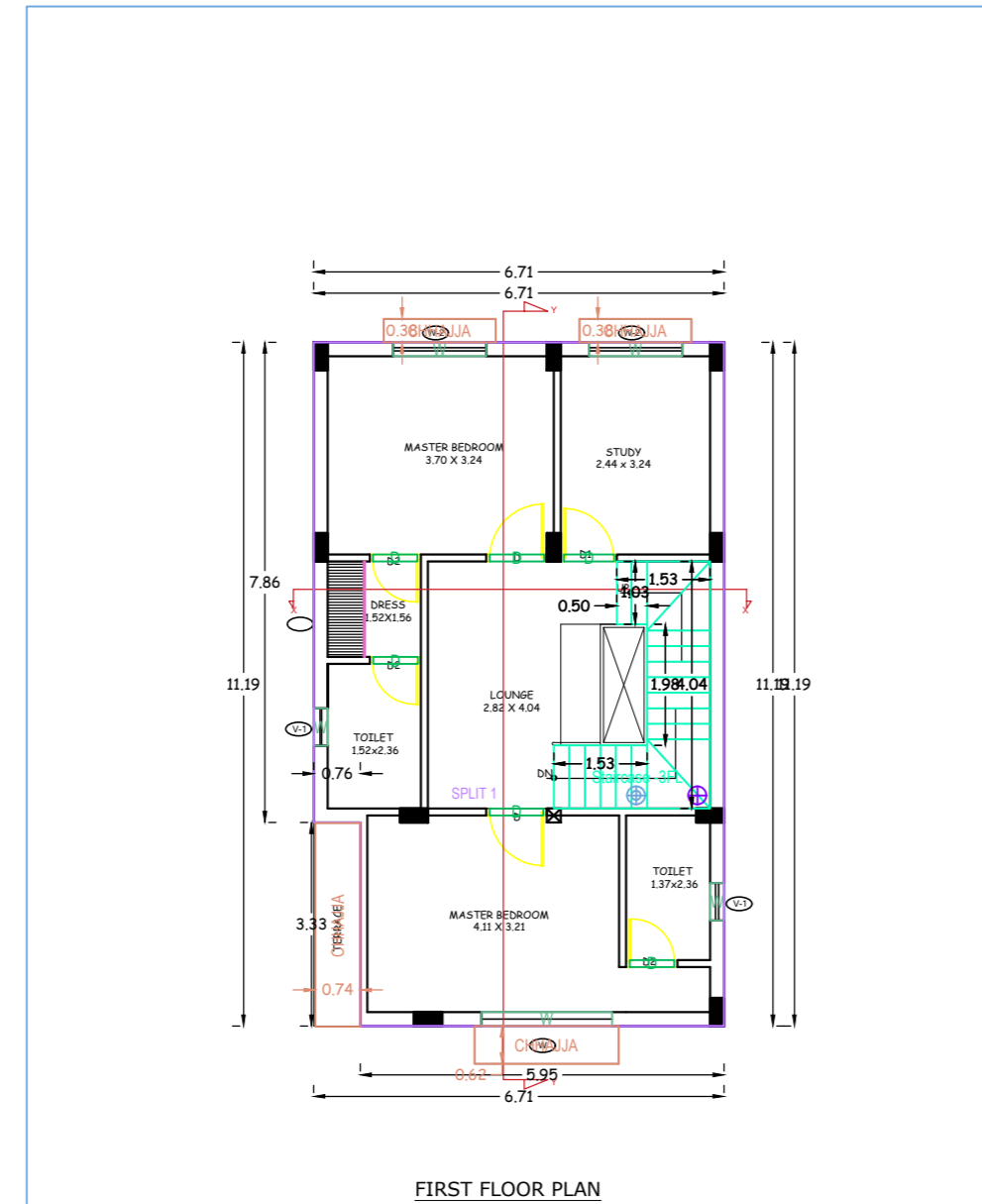

FIRST FLOOR PLAN

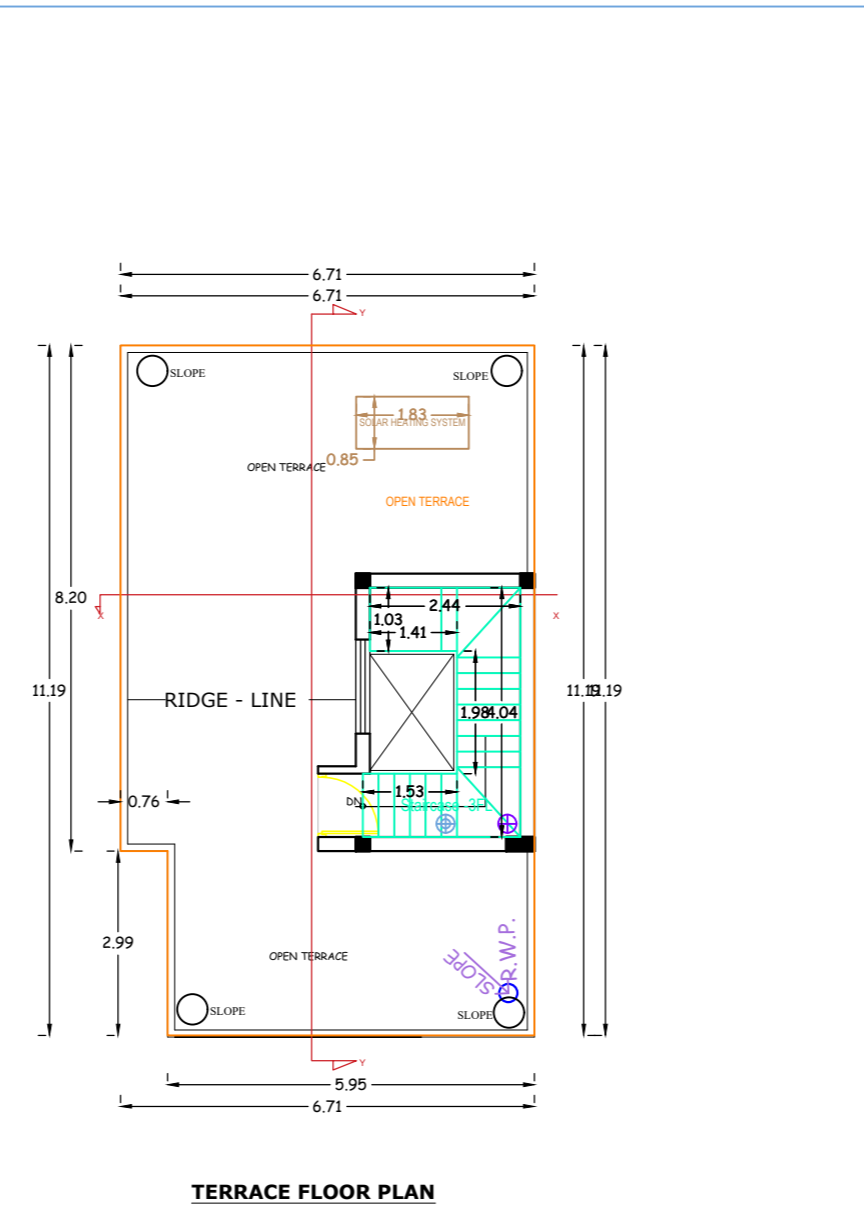

TERRACE FLOOR PLAN

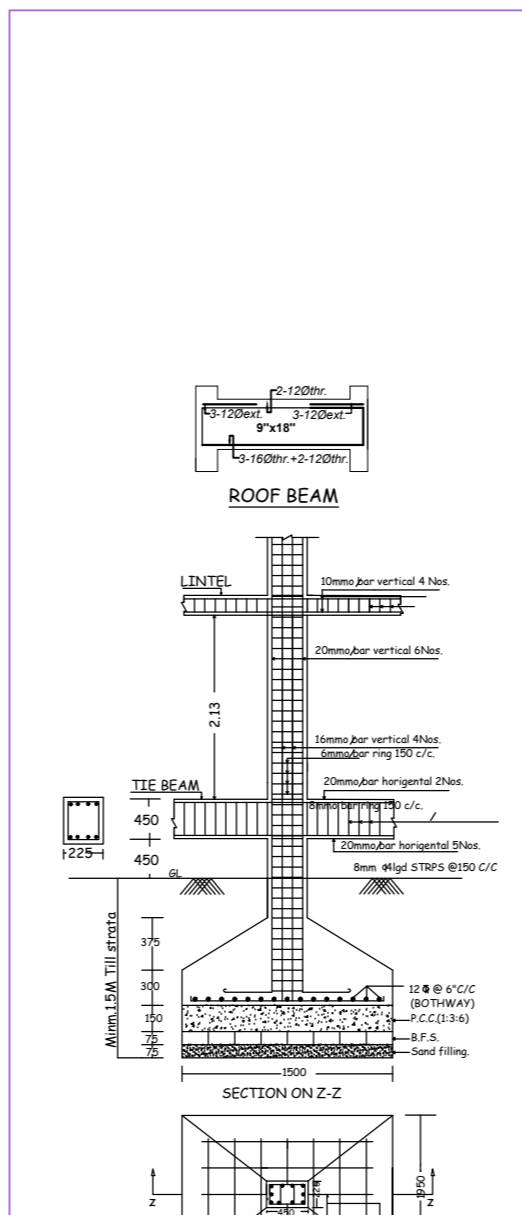

DETAIL OF COLUMNS  
SCALE:1:25

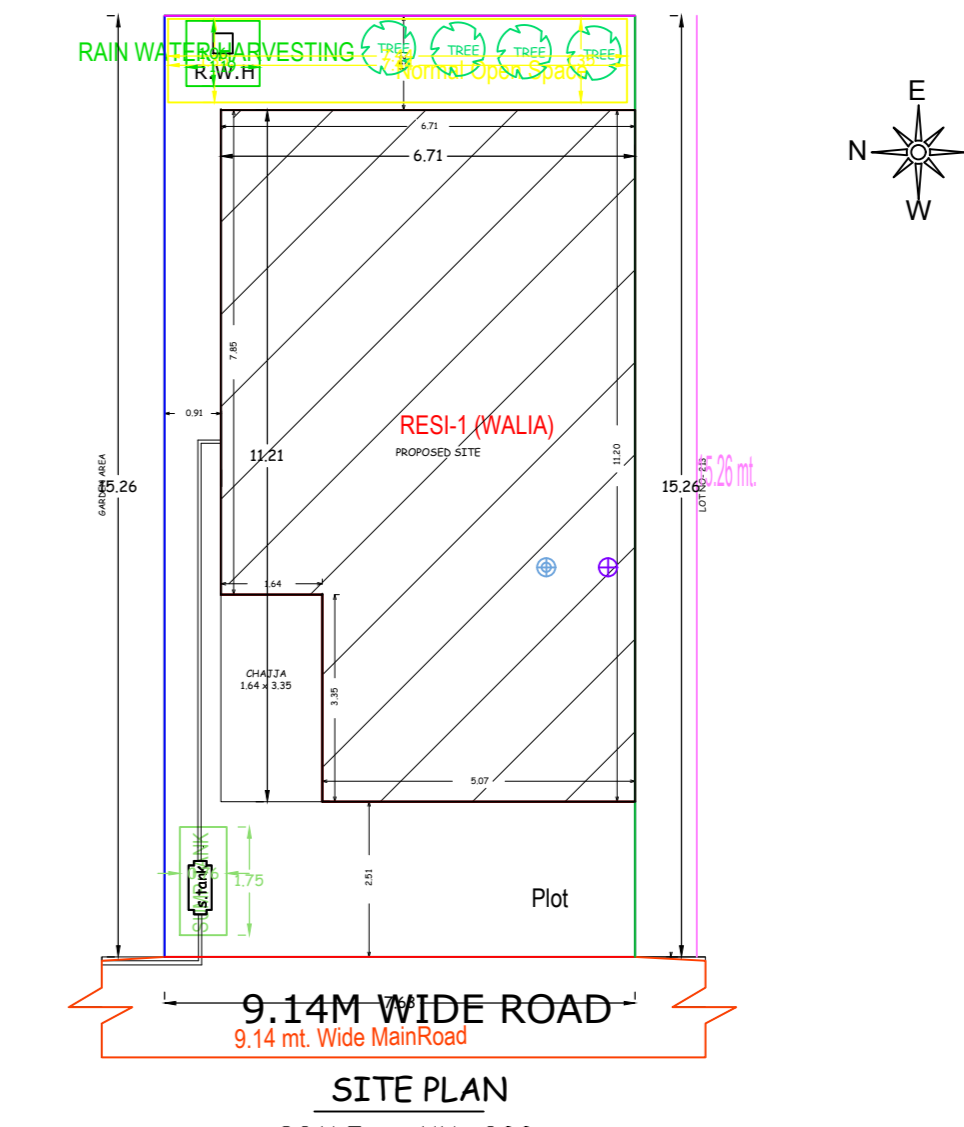

SITE PLAN  
SCALE :- 1:100

AREA STATEMENT: MINERAL AREA DEVELOPMENT AUTHORITY		VERSION NO: 1.0	DATE: 10/05/2020
PROJECT DETAIL:			
Project No.:	Residential	Plot Line:	Residential
Region:	SHARHARDI/URBAN LOCAL BODIES	Plot Location:	Burgahat Dwelling / Non-Apartment
Location:	SHARHARDI	Land Use Zone:	RES
Application Type:	General Proposal	Adjoining Side/Width:	
Project Type:	Building Permission	Project No.:	
Category of Development:	New	Reference Survey No/Survey No.:	
Location:	Old Area	Thana No.:	
Block Location:	NA	Plotting No.:	
Village/Moza Name:		Khata No.:	
Block No.:		North:	
Plot No.:		South:	
Plot Size:		East:	
Plot Shape:		West:	
AREA DETAILS:		Area:	50 MT
AREA OF PLOT (Minimum)	(A)		116.42
Net Plot Area (Gross Plot Area - Deductions from Gross Plot Area)	(A-Deductions)		116.40
Deductions for Balance Plot Area (From Gross Plot Area)			0.02
COP Area			52.07
Total			109.33
Balance Plot Area (Net Plot Area - Developmental Area)	(A-Deductions)		109.33
Plot Area for Coverage (Net Plot Area - Developmental Area)	(A-Deductions)		116.40
Plot Area for FSI (Net Plot Area + Developmental Area)	(A-Deductions)		116.40
COVERAGE CHECK			
Proposed Coverage Area (30.35%)			63.72
Total Coverage Area (30.35%)			63.72
FAR CHECK			
Proposed Area of FAR			142.35
Total Area of FAR			142.35
RECTY OF AREA CHECK			
Net Proposed Built-Up Area			142.35
RECTY OF SUPERSTORY HEIGHT			
			OTHER
DEVELOPMENT AUTHORITY		LOCAL BODY	

COLOR INDEX			
Plot Boundary			
Abutting Road			
Proposed Work (Coverage Area)			
Existing (To be retained)			
Existing (To be demolished)			

COLOR INDEX					
MASON DETAIL					
Brick	Wing	Block Name	Front Margin	Rear Margin	Side Margin
RESI (WALIA)	1	9.15 mt. Wing	2.02	1.53	0.92
		Masonry			0.92

FAR & Tenement Details (Table 4C-1)					
Building	No. of Same Bldg.	Proposed FAR Area (Sq.m)	Total FAR Area (Sq.m)	FAR (%)	Trmt (%)
RESI (WALIA)	1	142.35	142.35	142.35	01
Grand Total:	1	142.35	142.35	142.35	01

Floor Name	Total Built Up Area (SQ.M)	Proposed FAR Area (SQ.M)	Total FAR Area (SQ.M)	Trmt (%)
Ground Floor:	68.78	68.78	68.78	01
First Floor:	72.57	72.57	72.57	00
Terrace Floor:	0.00	0.00	0.00	00
Total:	142.35	142.35	142.35	01
Total Number of Same Buildings	1			
Total:	142.35	142.35	142.35	01

BEARING NAME	NAME	LENGTH	HEIGHT	NOSS
RESI (WALIA)	D	0.68	2.10	01
RESI (WALIA)	D	0.73	2.10	03
RESI (WALIA)	D	0.79	2.10	01
RESI (WALIA)	D	0.81	2.10	01
RESI (WALIA)	D	0.82	2.10	01
RESI (WALIA)	D	0.88	2.10	01
RESI (WALIA)	D	0.89	2.10	02
RESI (WALIA)	D	0.92	2.10	01
RESI (WALIA)	D	1.07	2.10	01
Total	-	-	-	12

BEARING NAME	NAME	LENGTH	HEIGHT	NOSS
RESI (WALIA)	W	0.61	1.20	04
RESI (WALIA)	W	1.07	1.20	01
RESI (WALIA)	W	1.22	1.20	01
RESI (WALIA)	W	1.53	1.20	03
RESI (WALIA)	W	2.16	1.20	01
Total	-	-	-	10

FLOOR	Name	UNB/LUA Type	UNB/LUA Area	Carpet Area	No. of Rooms	No. of Tenement
GROUND FLOOR PLAN	SPLIT 1	FLAT	142.35	140.29	6	1
Total	-	-	142.35	140.29	13	1