

SITE PLAN  
SCALE :- 1/11N=200

SITE PLAN

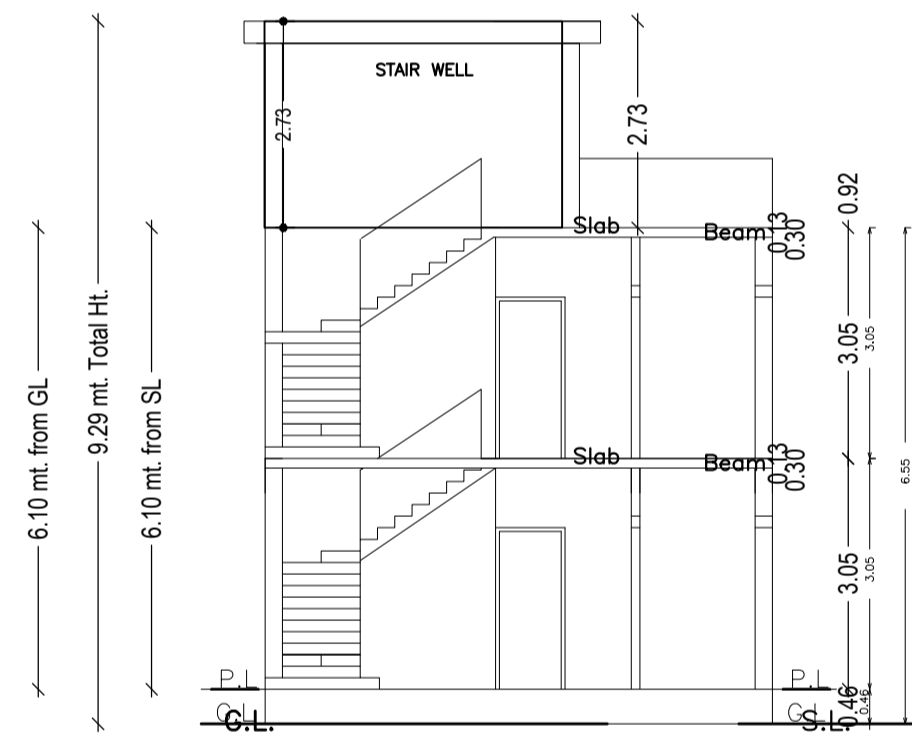

SECTION AT X-X

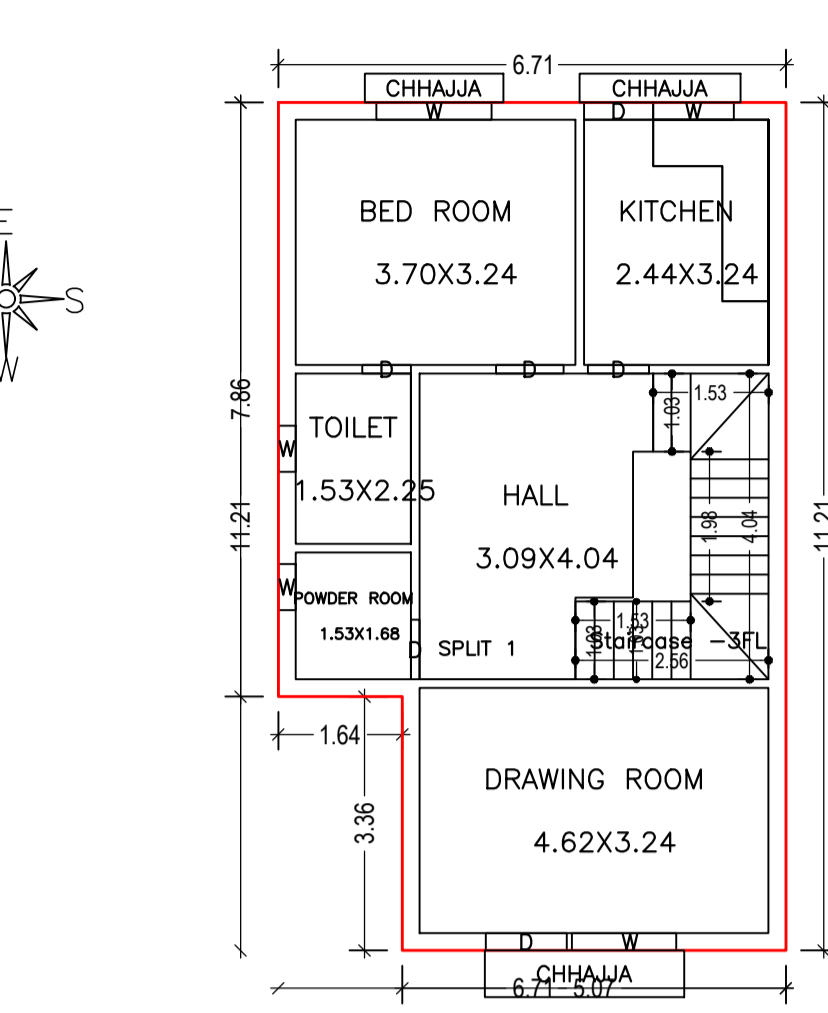

GROUND FLOOR PLAN  
(Proposed)  
(SCALE 1:100)

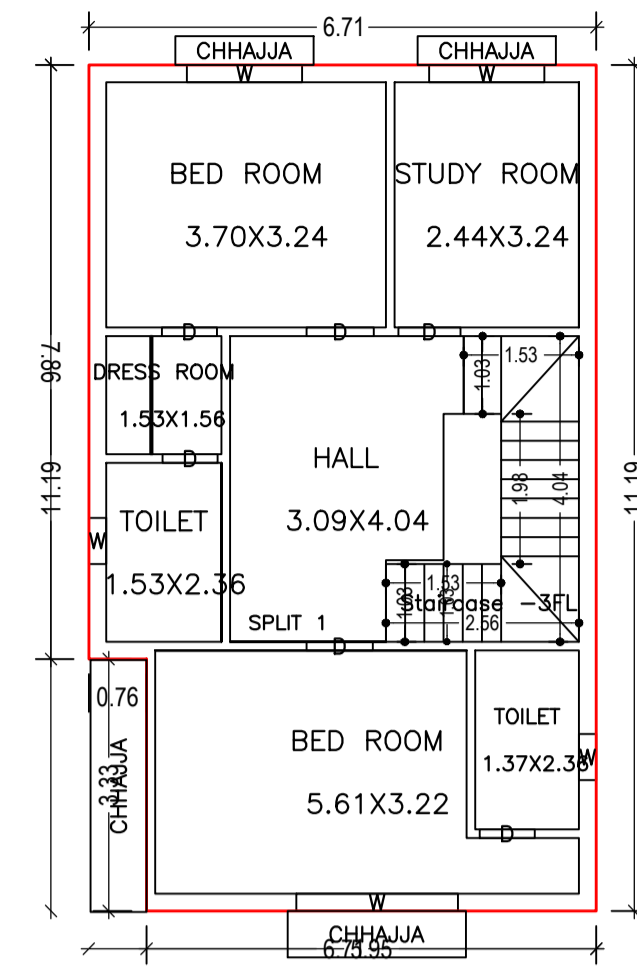

FIRST FLOOR PLAN  
(Proposed)  
(SCALE 1:100)

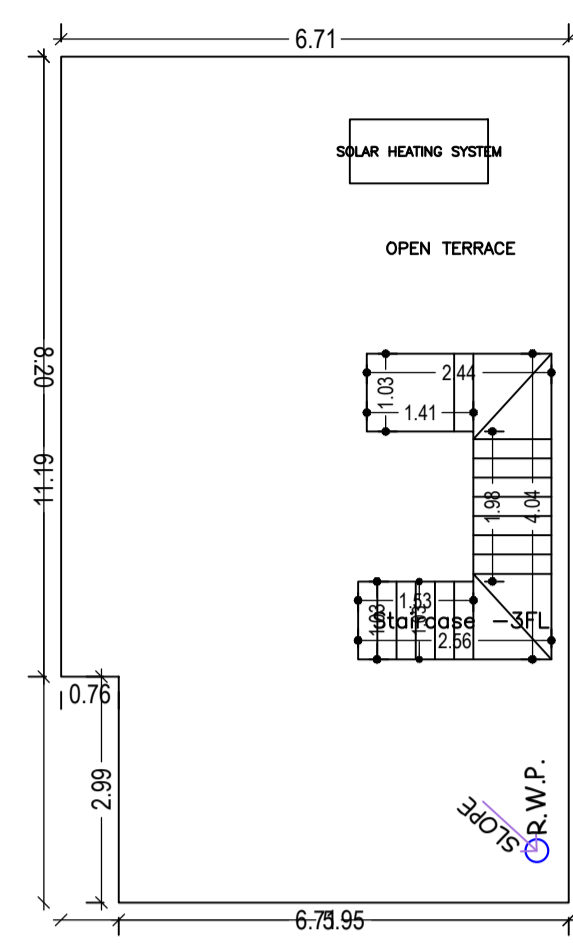

TERRACE FLOOR PLAN  
(SCALE 1:100)

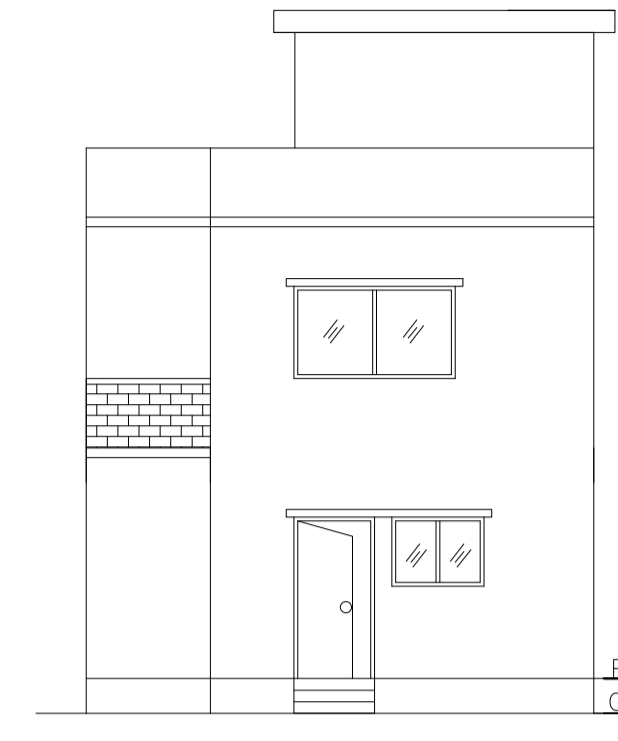

FRONT ELEVATION

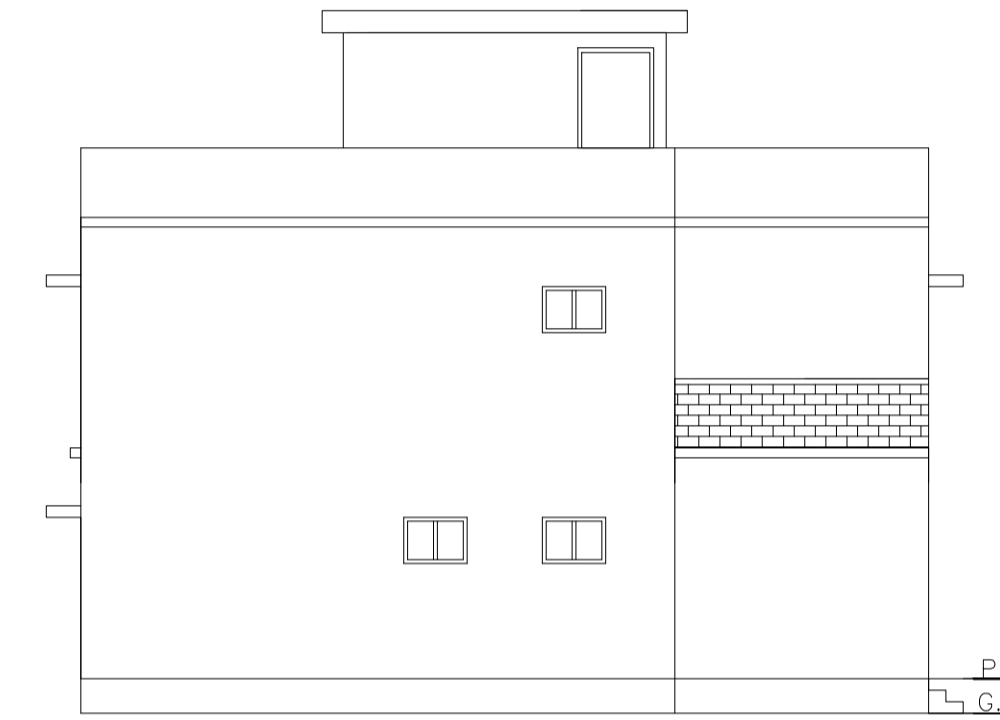

LEFT SIDE ELEVATION

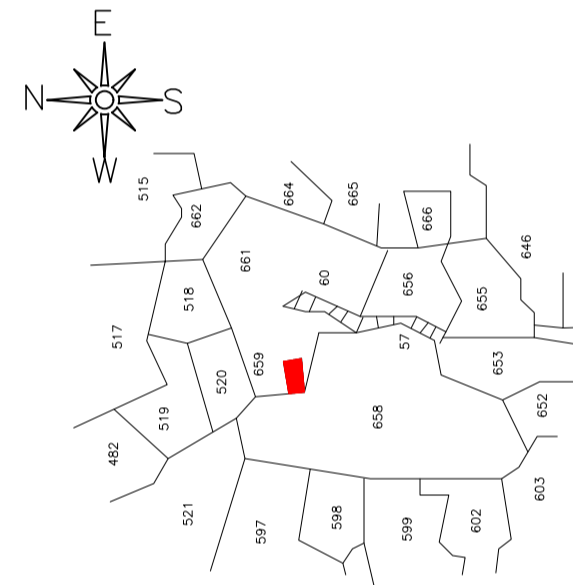

KEY PLAN  
NOT TO SCALE

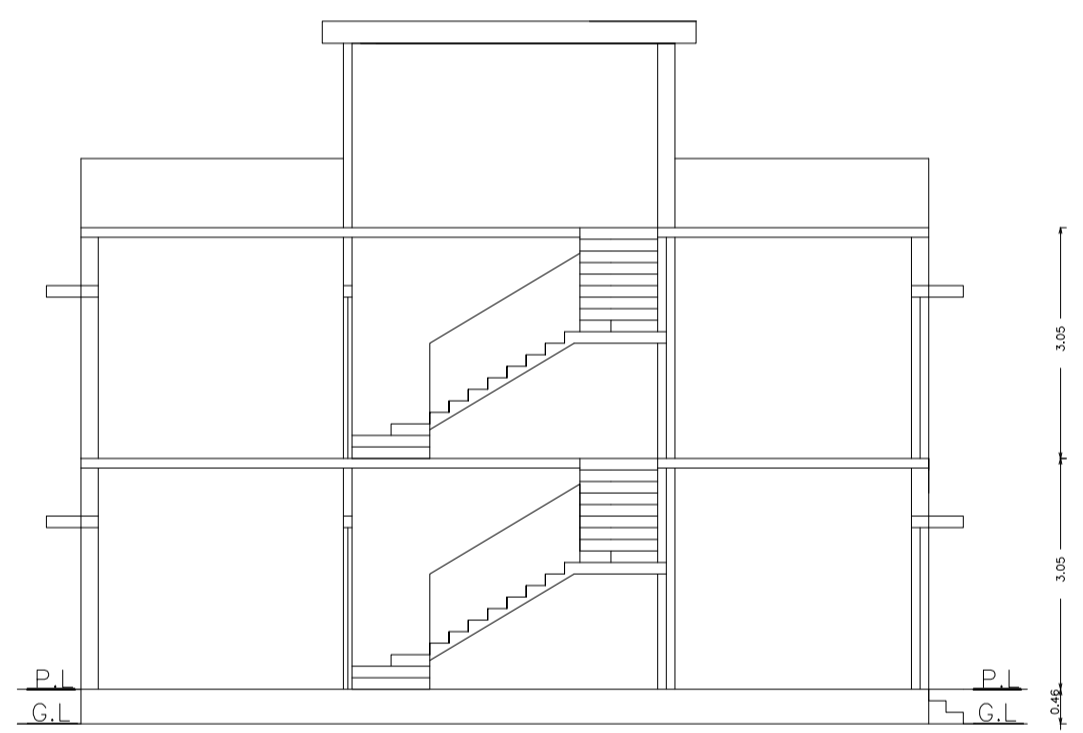

SECTION AT Y-Y

Building :RESI (WALIA)

Floor Name	Total Built Up Area (Sq.mt.)	Proposed FAR Area (Sq.mt.)	Total FAR Area (Sq.mt.)	Total Consumed Additional FAR Area (Sq.mt.)	Tnmt (No.)
Ground Floor	69.78	69.78	69.78	69.78	01
First Floor	72.57	72.57	72.57	72.57	00
Terrace Floor	0.00	0.00	0.00	0.00	00
<b>Total :</b>	<b>142.35</b>	<b>142.35</b>	<b>142.35</b>	<b>142.35</b>	<b>01</b>
Total Number of Same Buildings	1				
<b>Total :</b>	<b>142.35</b>	<b>142.35</b>	<b>142.35</b>	<b>142.35</b>	<b>01</b>

SCHEDULE OF DOOR:

BUILDING NAME	NAME	LENGTH	HEIGHT	NOS
RESI (WALIA)	D	0.65	2.10	01
RESI (WALIA)	D	0.73	2.10	03
RESI (WALIA)	D	0.79	2.10	01
RESI (WALIA)	D	0.81	2.10	01
RESI (WALIA)	D	0.82	2.10	01
RESI (WALIA)	D	0.88	2.10	01
RESI (WALIA)	D	0.89	2.10	02
RESI (WALIA)	D	0.92	2.10	01
RESI (WALIA)	D	1.07	2.10	01

SCHEDULE OF WINDOW/VENTILATION:

BUILDING NAME	NAME	LENGTH	HEIGHT	NOS
RESI (WALIA)	W	0.61	1.20	04
RESI (WALIA)	W	1.07	1.20	01
RESI (WALIA)	W	1.38	1.20	01
RESI (WALIA)	W	1.53	1.20	03
RESI (WALIA)	W	2.14	1.20	01

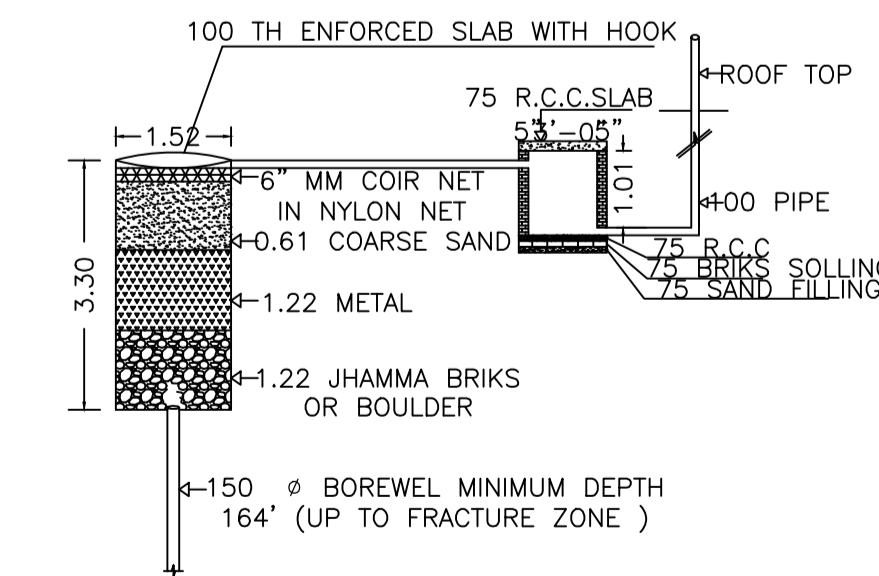

DETAIL OF GROUND WATER RECHARGING PIT WITH SILT TANK  
NOT TO SCALE

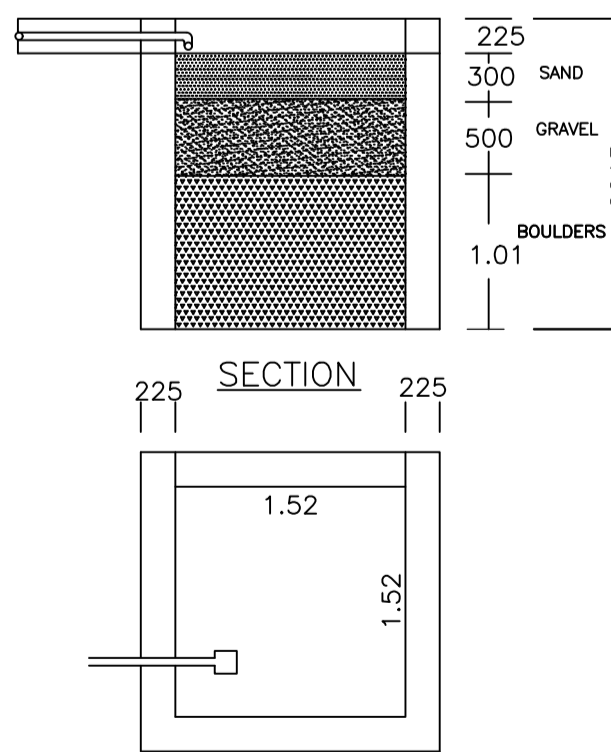

PLAN OF RAIN WATER HARVESTING  
(SCALE:-1:25)

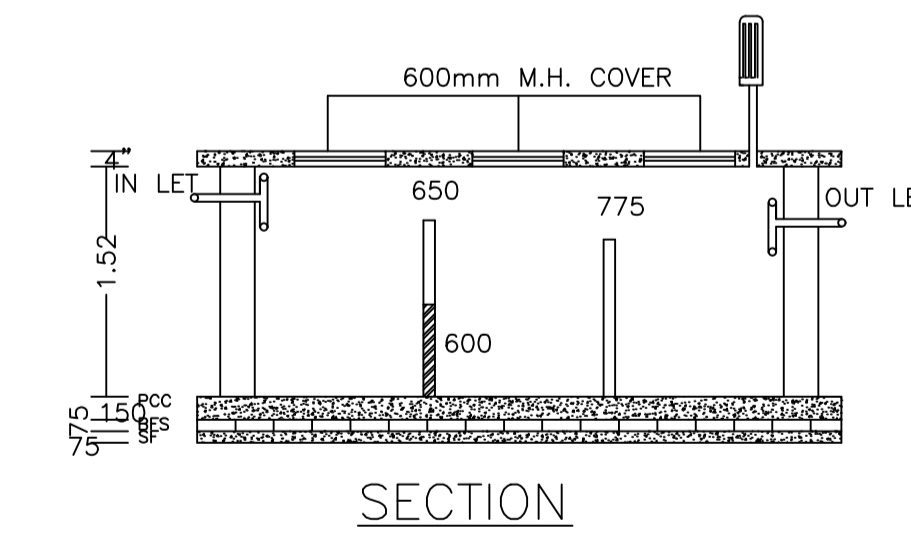

PLAN OF SEPTIC TANK  
(SCALE:-1:25.)

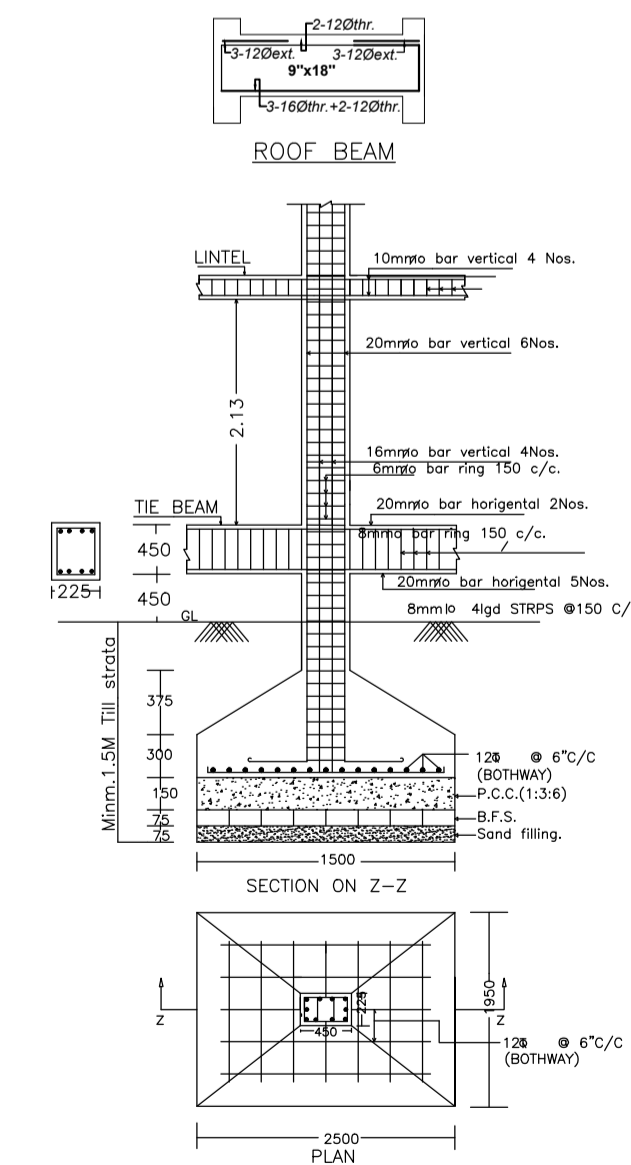

DETAIL OF COLUMNS  
SCALE:- 1:25

Proposal Basic Information

Proposal File No.	MADA/BP/0182/2023
Owner Name	SMT.NIMMI WALIA
Khata No	57 (OLD), 146 (NEW)
Plot No	579 (OLD),659 (NEW)
Village Name	Amaghata
Use	Residential
SubUse	Bungalow/ Dwelling / Non Apartment

AREA STATEMENT MINERAL AREA DEVELOPMENT AUTHORITY	VERSION NO. : 1.0.66 VERSION DATE: 16/10/2020
PROJECT DETAIL:	
Region: JHARKHAND URBAN LOCAL BODIES	Plot Use: Residential
District: DHANBAD	Plot SubUse: Bungalow/ Dwelling / Non Apartment
Authority: MINERAL AREA DEVELOPMENT AUTHORITY	PlotNearbyReligiousStructure: NA
Inward No: MADA/BP/0182/2023	Plot/SubPlot No: 579 (OLD),659 (NEW)
Application Type: General Proposal	North: Plot No. - GARDEN AREA
Project Type: Building Permission	South: Plot No. - LOT NO-213
Nature of Development: New	East: Plot No. - BOUNDARY WALL
Location of Development Area: Old Area	West: Road Width - 9.14

AREA DETAILS:		SQ.MT.
AREA OF PLOT (Minimum)	(A)	115.71
NET AREA OF PLOT(Gross Plot Area - Deduction from Gross Plot area)	(A-Deductions)	115.71
Deduction for Balance Plot Area(from Gross Plot Area)		
Common Plot		10.07
Total		10.07
BALANCE AREA OF PLOT(Net Plot Area - Recreational/Amenity space)	(A-Deductions)	105.64
PLOT AREA FOR COVERAGE(Net Plot Area)	(A-Deductions)	115.71
Plot Area for FAR (Net Plot Area + RoadWidening Area)	(A-Deductions)	115.71

COVERAGE CHECK		
Permissible Coverage Area ( 70.00 % )		81.00
Proposed Coverage Area ( 60.30 % )		69.78
Total Prop. Coverage Area ( 60.3 % )		69.78
Balance coverage area ( 9.70 % )		11.22

FAR CHECK		
Perm. FAR Area ( 2.500 )		289.27
Total Perm. FAR area		289.27
Residential FAR		142.36
Proposed FAR Area		142.36
Total Proposed FAR Area		142.36
Consumed FAR (Factor)		1.23
Balance FAR Area		146.91

BUILT UP AREA CHECK		
Total Proposed BuiltUp Area		142.35
ARCHITECT (Regd)		Kumari Rinku Rani
ENGINEER (Regd)		
SUPERVISOR (Regd)		
OWNER (Regd)		SMT NIMMI WALIA

DEVELOPMENT AUTHORITY	LOCAL BODY
COLOR INDEX	
PLOT BOUNDARY	Black
ABUTTING ROAD	Red
PROPOSED CONSTRUCTION	Green
COMMON PLOT	Yellow
ROAD WIDENING AREA	Blue
EXISTING (To be retained)	Orange
EXISTING (To be demolished)	Purple

Buildingwise Floor FAR Details				
Floor Name	Building Name RESI (WALIA)		Total	
	Proposed Built Up Area (Sq.mt.)	Proposed FAR Area (Sq.mt.)	Total Proposed Built Up Area (Sq.mt.)	Total FAR Area (Sq.mt.)
Ground Floor	69.78	69.78	69.78	69.78
First Floor	72.57	72.57	72.57	72.57
Terrace Floor	0.00	0.00	0.00	0.00
<b>Total :</b>	<b>142.35</b>	<b>142.35</b>	<b>142.35</b>	<b>142.35</b>

Building USE/SUBUSE Details				
Building Name	Building Use	Building SubUse	Building Structure	
RESI (WALIA)	Residential	Bungalow/ Dwelling / Non Apartment	Non-Highrise	

FAR & Tenement Details (Table 4c-1)						
Building	No. of Same Bldg	Total Built Up Area (Sq.mt.)	Proposed FAR Area (Sq.mt.)	Total FAR Area (Sq.mt.)	Total Consumed Additional FAR Area (Sq.mt.)	Tnmt (No.)
RESI (WALIA)	1	142.35	142.35	142.35	142.35	01
<b>Grand Total :</b>	<b>1</b>	<b>142.35</b>	<b>142.35</b>	<b>142.35</b>	<b>142.35</b>	<b>01</b>

UnitBUA Table for Building :RESI (WALIA)						
FLOOR	Name	UnitBUA Type	UnitBUA Area	Carpet Area	No. of Rooms	No. of Tenement
GROUND FLOOR PLAN	SPLIT 1	FLAT	142.36	140.29	6	1
FIRST FLOOR PLAN	SPLIT 1	FLAT	0.00	0.00	7	0
<b>Total:</b>	-	-	<b>142.36</b>	<b>140.29</b>	<b>13</b>	<b>1</b>

LTP NAME AND SIGNATURE Kumari Rinku Rani MADA/ENG/0001/2023	STRUCTURAL ENG'S NAME AND SIGNATURE	BUILDER NAME AND SIGNATURE	DIGITAL SIGNATURE
---	-------------------------------------	----------------------------	-------------------