

FAR & Tenement Details (Table 4c-1)

Building	No. of Same Bldg	Total Built Up Area (Sq.mt.)	Proposed FAR Area (Sq.mt.)	Total FAR Area (Sq.mt.)	Total Consumed Additional FAR Area (Sq.mt.)	Tnmt (No.)
A (RABIYA PARWEEN)	1	185.64	185.64	185.64	185.64	01
Grand Total :	1	185.64	185.64	185.64	185.64	01

SCHEDULE OF DOOR:

BUILDING NAME	NAME	LENGTH	HEIGHT	NOS
A (RABIYA PARWEEN)	D	0.84	2.10	04
A (RABIYA PARWEEN)	D	0.91	2.10	04
A (RABIYA PARWEEN)	D	1.07	2.10	08
A (RABIYA PARWEEN)	D	1.23	2.10	01

SCHEDULE OF WINDOW/VENTILATION:

BUILDING NAME	NAME	LENGTH	HEIGHT	NOS
A (RABIYA PARWEEN)	V	0.61	1.20	04
A (RABIYA PARWEEN)	W	0.91	1.20	04
A (RABIYA PARWEEN)	W	1.22	1.20	12
A (RABIYA PARWEEN)	W	1.97	1.20	02

Building :A (RABIYA PARWEEN)

Floor Name	Total Built Up Area (Sq.mt.)	Proposed FAR Area (Sq.mt.)	Total FAR Area (Sq.mt.)	Total Consumed Additional FAR Area (Sq.mt.)	Tnmt (No.)
Ground Floor	92.82	92.82	92.82	92.82	01
First Floor	92.82	92.82	92.82	92.82	00
Terrace Floor	0.00	0.00	0.00	0.00	00
Total :	185.64	185.64	185.64	185.64	01
Total Number of Same Buildings	1	185.64	185.64	185.64	01

UnitBUA Table for Building :A (RABIYA PARWEEN)

FLOOR	Name	UnitBUA Type	UnitBUA Area	Carpet Area	No. of Rooms	No. of Tenement
GROUND FLOOR PLAN	SPLIT A	FLAT	185.65	185.50	8	1
FIRST FLOOR PLAN	SPLIT A	FLAT	0.00	0.00	8	0
Total :	-	-	185.65	185.50	16	1

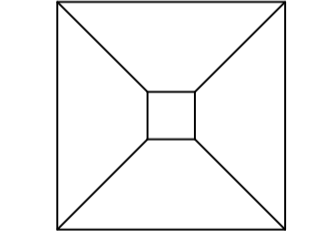
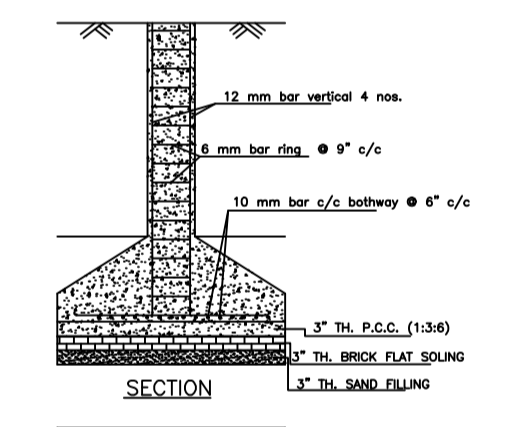
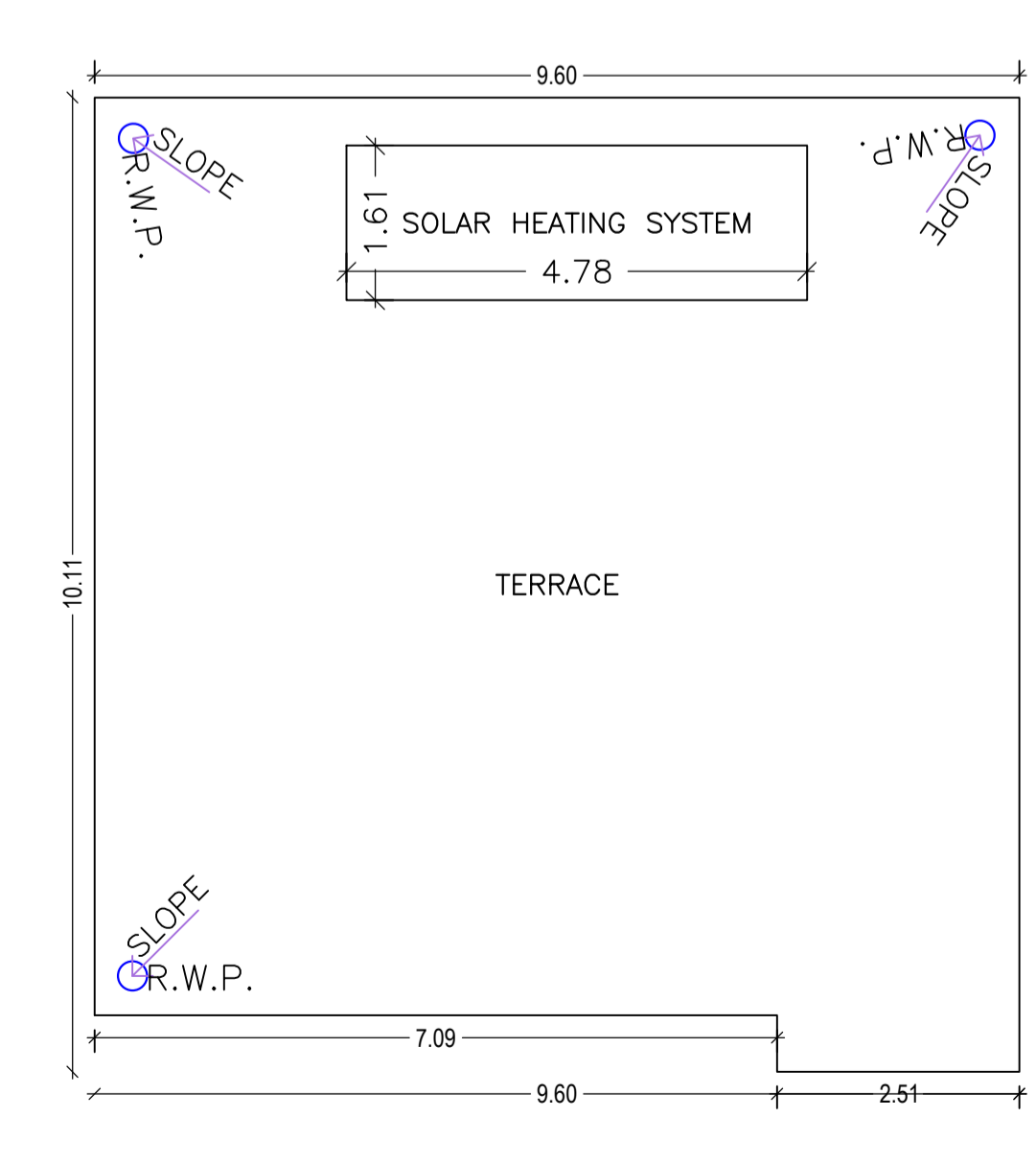
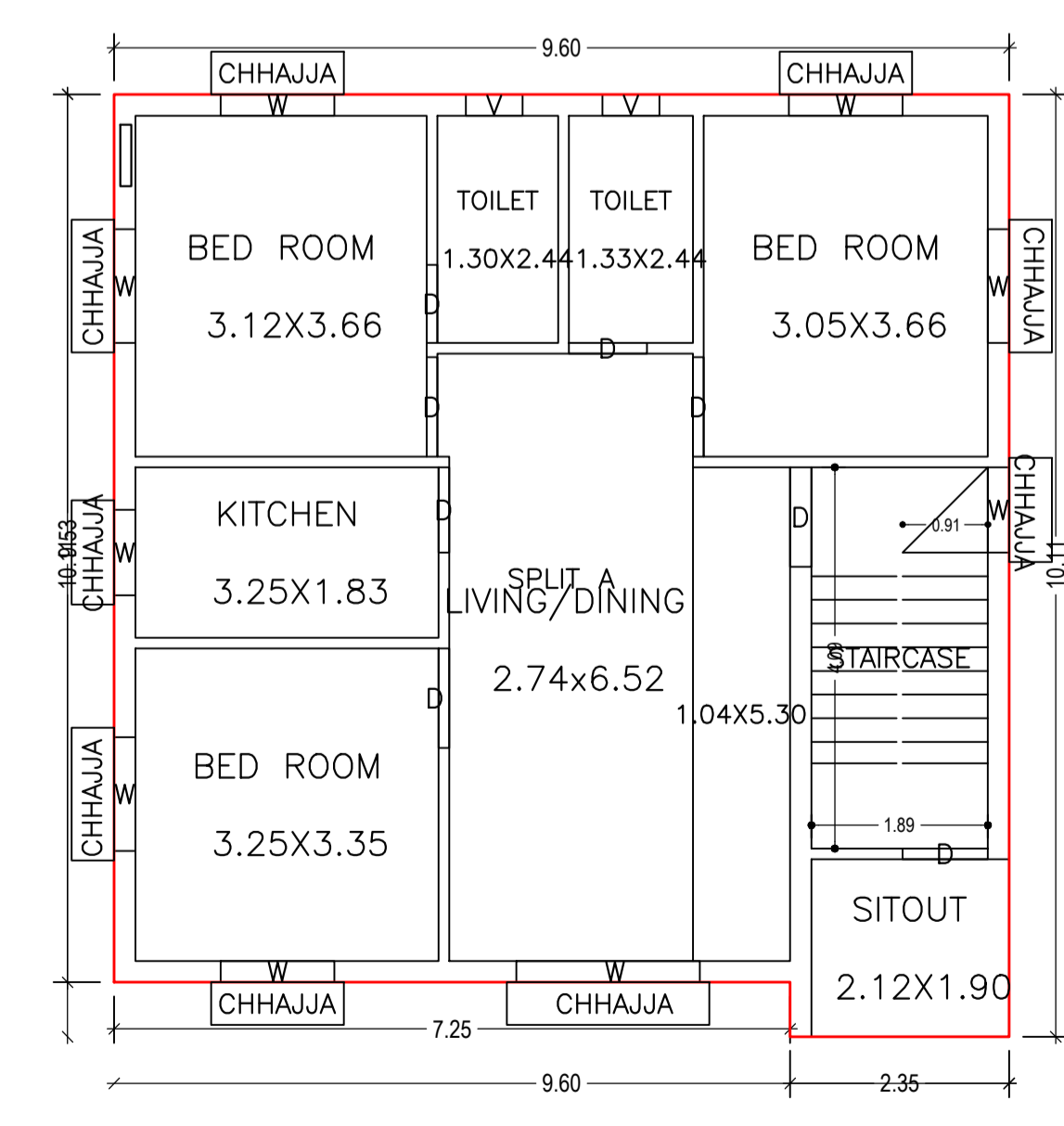
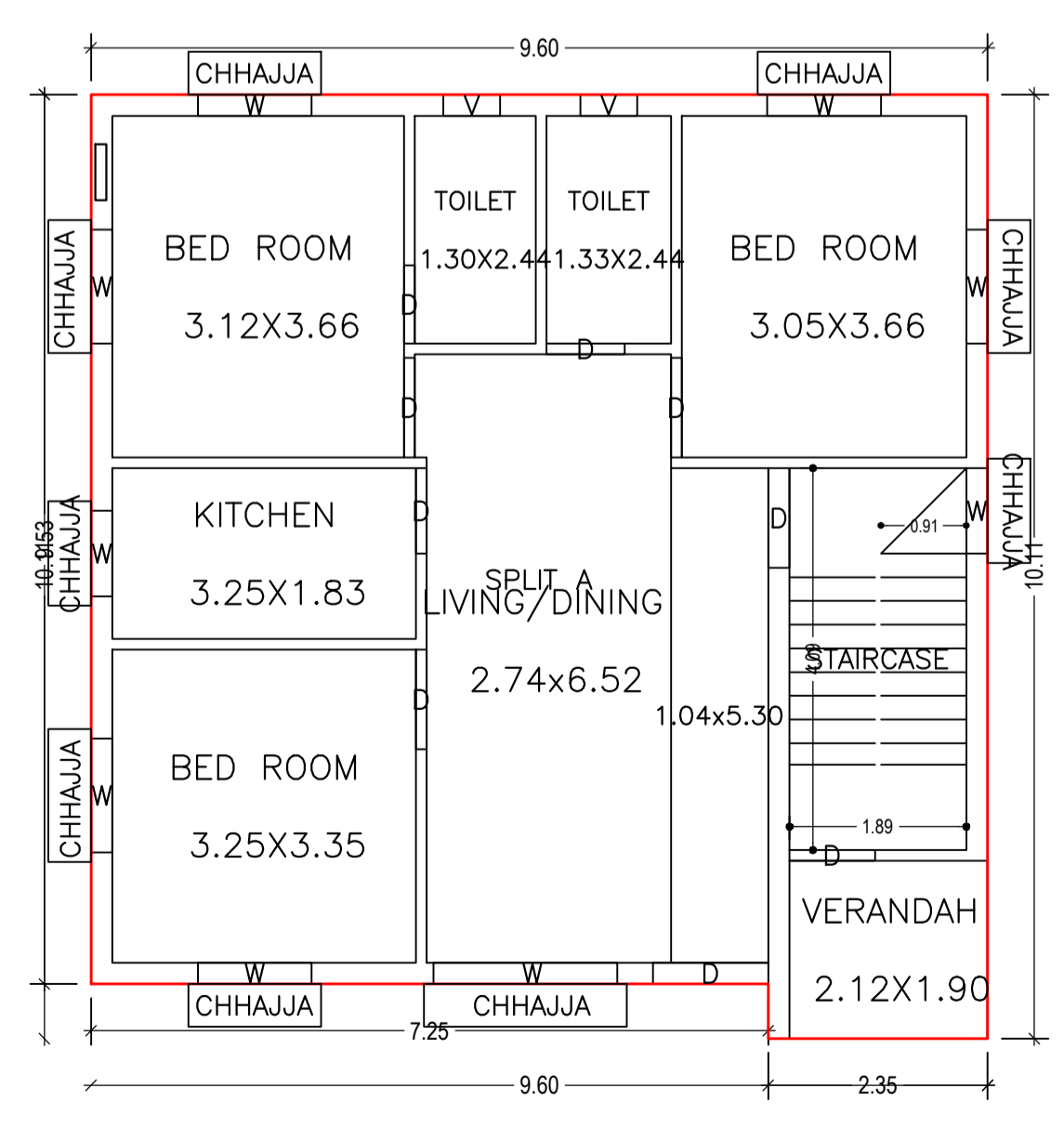

DETAILS OF COLUMN FOUNDATION
SCALE - 1" = 2'-0"

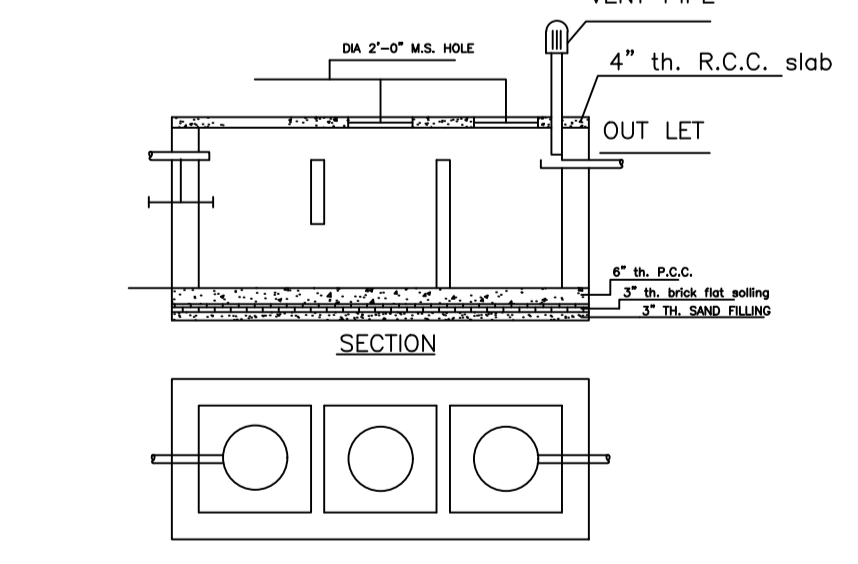

DETAILS OF SEPTIC TANK
SCALE - 1" = 4'-0"

ROOF TOP RAIN WATER COLLECTION SYSTEM

Proposal Basic Information

Proposal File No.	MADA/BP/0186/2023
Owner Name	RABIYA PARWEEN
Khata No	OLD KHATA NO-24, NEW KHATA NO-179
Plot No	OLD PLOT NO-1307, NEW PLOT NO-1150
Village Name	Kurmidi
Use	Residential
SubUse	Bungalow/ Dwelling / Non Apartment

AREA STATEMENT MINERAL AREA DEVELOPMENT AUTHORITY	VERSION NO. : 1.0.66	VERSION DATE: 16/10/2020
PROJECT DETAIL:	Region: JHARKHAND URBAN LOCAL BODIES	Plot Use: Residential
District: DHANBAD	Plot SubUse: Bungalow/ Dwelling / Non Apartment	PlotNearby/ReligiousStructure: NA
Authority: MINERAL AREA DEVELOPMENT AUTHORITY	Inward_No: MADA/BP/0186/2023	Plot/SubPlot No: OLD PLOT NO-1307, NEW PLOT NO-1150
Application Type: General Proposal	Project Type: Building Permission	North: Plot No. - SAME PLOT
Nature of Development: New	East: Road Width - 6.10	South: Road Width - 6.10
Location of Development Area: Old Area	West: Plot No. - SAME PLOT	
AREA DETAILS:		SQ.MT.
AREA OF PLOT (Minimum)	(A)	157.71
NET AREA OF PLOT(Gross Plot Area - Deduction from Gross Plot area)	(A-Deductions)	157.71
Deduction for Balance Plot Area(from Gross Plot Area)		
Common Plot		18.79
Total		18.79
BALANCE AREA OF PLOT(Net Plot Area - Recreational/Amenity space)	(A-Deductions)	138.92
PLOT AREA FOR COVERAGE(Net Plot Area)	(A-Deductions)	157.71
Plot Area for FAR (Net Plot Area + Road/Widening Area)	(A-Deductions)	157.71
COVERAGE CHECK		
Permissible Coverage area (70.00 %)		110.40
Proposed Coverage Area (58.86 %)		92.82
Total Prop. Coverage Area (58.86 %)		92.82
Balance coverage area (11.15 %)		17.58
FAR CHECK		
Perm. FAR Area (2.500)		394.28
Total Perm. FAR area		394.28
Residential FAR:		185.65
Proposed FAR Area		185.65
Total Proposed FAR Area		185.65
Consumed FAR (Factor)		1.18
Balance FAR Area		208.63
BUILT UP AREA CHECK		
Total Proposed BuiltUp Area		185.64
ARCHITECT (Regd)		RAM PRATAP SINGH
ENGINEER (Regd)		
SUPERVISOR (Regd)		
OWNER (Regd)		RABIYA PARWEEN
DEVELOPMENT AUTHORITY		LOCAL BODY

COLOR INDEX

PLOT BOUNDARY	Black
ABUTTING ROAD	Green
PROPOSED CONSTRUCTION	Red
COMMON PLOT	Yellow
ROAD WIDENING AREA	Blue
EXISTING (To be retained)	Light Blue
EXISTING (To be demolished)	Light Yellow

Buildingwise Floor FAR Details

Floor Name	Building Name A (RABIYA PARWEEN)		Total	
	Proposed Built Up Area (Sq.mt.)	Proposed FAR Area (Sq.mt.)	Total Proposed Built Up Area (Sq.mt.)	Total FAR Area (Sq.mt.)
Ground Floor	92.82	92.82	92.82	92.82
First Floor	92.82	92.82	92.82	92.82
Terrace Floor	0.00	0.00	0.00	0.00
Total :	185.64	185.64	185.64	185.64

Building USE/SUBUSE Details

Building Name	Building Use	Building SubUse	Building Structure
A (RABIYA PARWEEN)	Residential	Bungalow/ Dwelling / Non Apartment	Non-Highrise

LTP NAME AND SIGNATURE	STRUCTURAL ENG'S NAME AND SIGNATURE	BUILDER NAME AND SIGNATURE	DIGITAL SIGNATURE
RAM PRATAP SINGH MADA/ARC/0024/2019			