

Proposal Basic Information	
Proposal File No.	MADA/BP/0358/2023
Owner Name	JAY PRAKASH YADAV, NIRU KUMARI
Khata No	OLD - 57, NEW - 96
Plot No	OLD - 1646, NEW - 2600
Village Name	Kurmidih
Use	Residential
SubUse	Bungalow/ Dwelling / Non Apartment

AREA STATEMENT MINERAL AREA DEVELOPMENT AUTHORITY		VERSION NO.: 1.0.68
PROJECT DETAIL:		VERSION DATE: 16/10/2020
Region: JHARKHAND URBAN LOCAL BODIES	Plot Use: Residential	
District: DHANBAD	Plot SubUse: Bungalow/ Dwelling / Non Apartment	
Authority: MINERAL AREA DEVELOPMENT AUTHORITY	PlotNearby/ReligiousStructure: NA	
Inward No: MADA/BP/0358/2023	Plot/SubPlot No: OLD - 1646, NEW - 2600	
Application Type: General Proposal	North: Plot No. - PART OF THIS PLOT	
Project Type: Building Permission	South: Plot No. - PART OF THIS PLOT	
Nature of Development: New	East: Road Width - 4.87	
Location of Development Area: Old Area	West: Plot No. - PART OF THIS PLOT	
AREA DETAILS:		
AREA OF PLOT (Minimum)	(A)	SQ.MT. 132.10
NET AREA OF PLOT(Gross Plot Area - Deduction from Gross Plot area)	(A-Deductions)	132.10
Deduction for Balance Plot Area(from Gross Plot Area)		
Common Plot		9.42
Total		9.42
BALANCE AREA OF PLOT(Net Plot Area - Recreational/Amenity space)	(A-Deductions)	122.67
PLOT AREA FOR COVERAGE(Net Plot Area)	(A-Deductions)	132.10
Plot Area for FAR (Net Plot Area + Road/Widening Area)	(A-Deductions)	132.10
COVERAGE CHECK		
Permissible Coverage area (70.00 %)		92.47
Proposed Coverage Area (58.12 %)		76.77
Total Prop. Coverage Area (58.12 %)		76.77
Balance coverage area (11.89 %)		15.70
FAR CHECK		
Perm. FAR Area (1.800)		237.78
Total Perm. FAR area		237.78
Residential FAR		154.55
Proposed FAR Area		154.55
Total Proposed FAR Area		154.55
Consumed FAR (Factor)		1.17
Balance FAR Area		83.23
BUILT UP AREA CHECK		
Total Proposed BuiltUp Area		155.54
ARCHITECT (Regd)	AMIT KUMAR	
ENGINEER (Regd)		
SUPERVISOR (Regd)		
OWNER (Regd)	JAY PRAKASH YADAV, NIRU KUMARI	
DEVELOPMENT AUTHORITY		LOCAL BODY

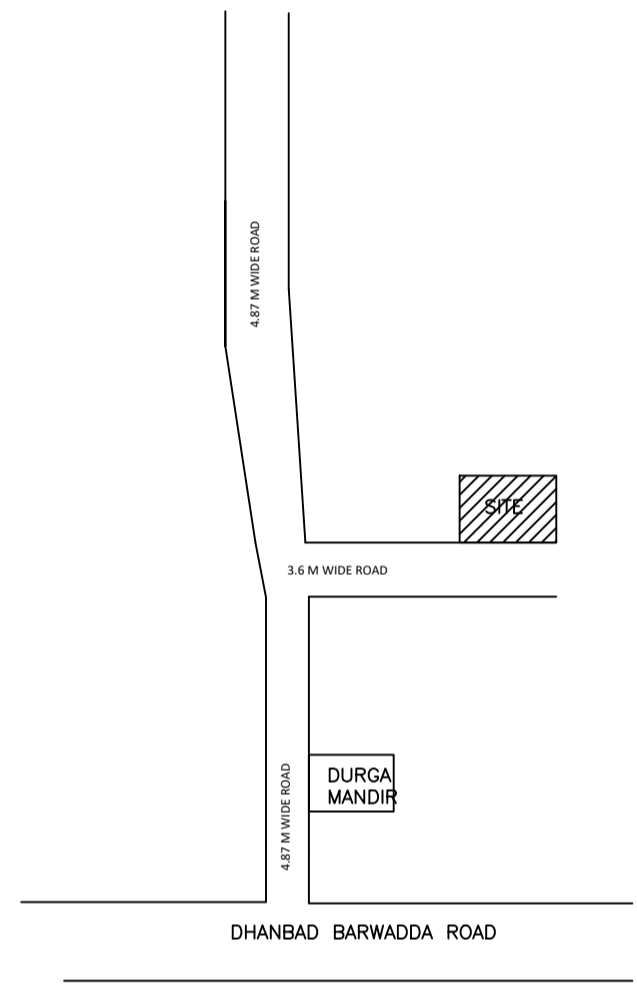

COLOR INDEX	
PLOT BOUNDARY	Black
ABUTTING ROAD	Green
PROPOSED CONSTRUCTION	Red
COMMON PLOT	Yellow
ROAD WIDENING AREA	Blue
EXISTING (To be retained)	Light Blue
EXISTING (To be demolished)	Dark Blue

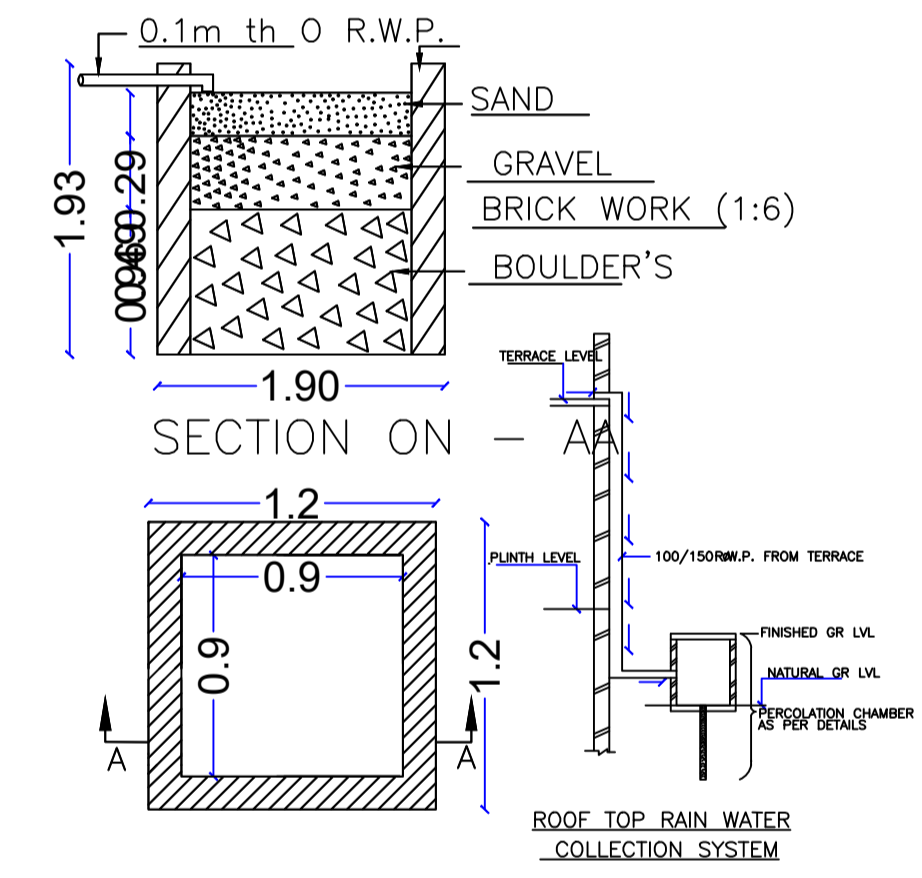
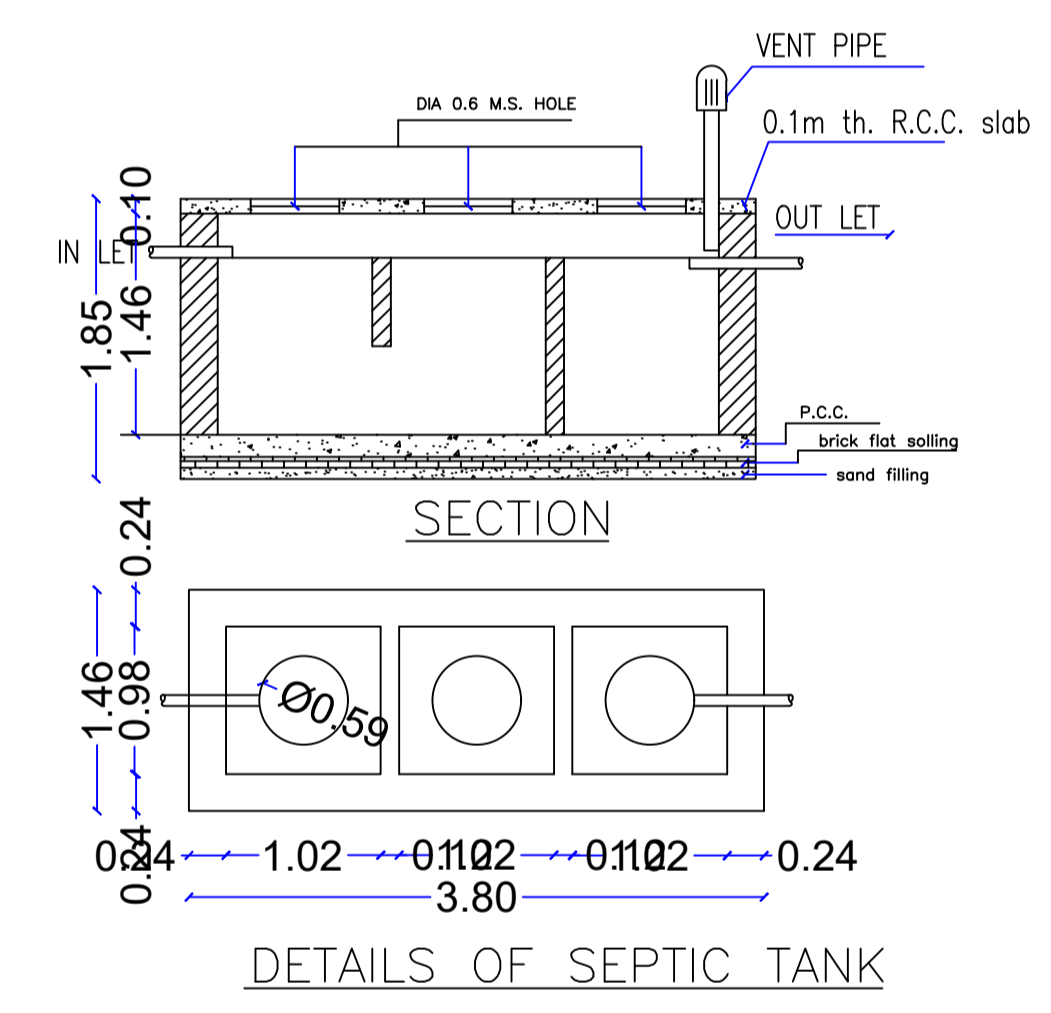
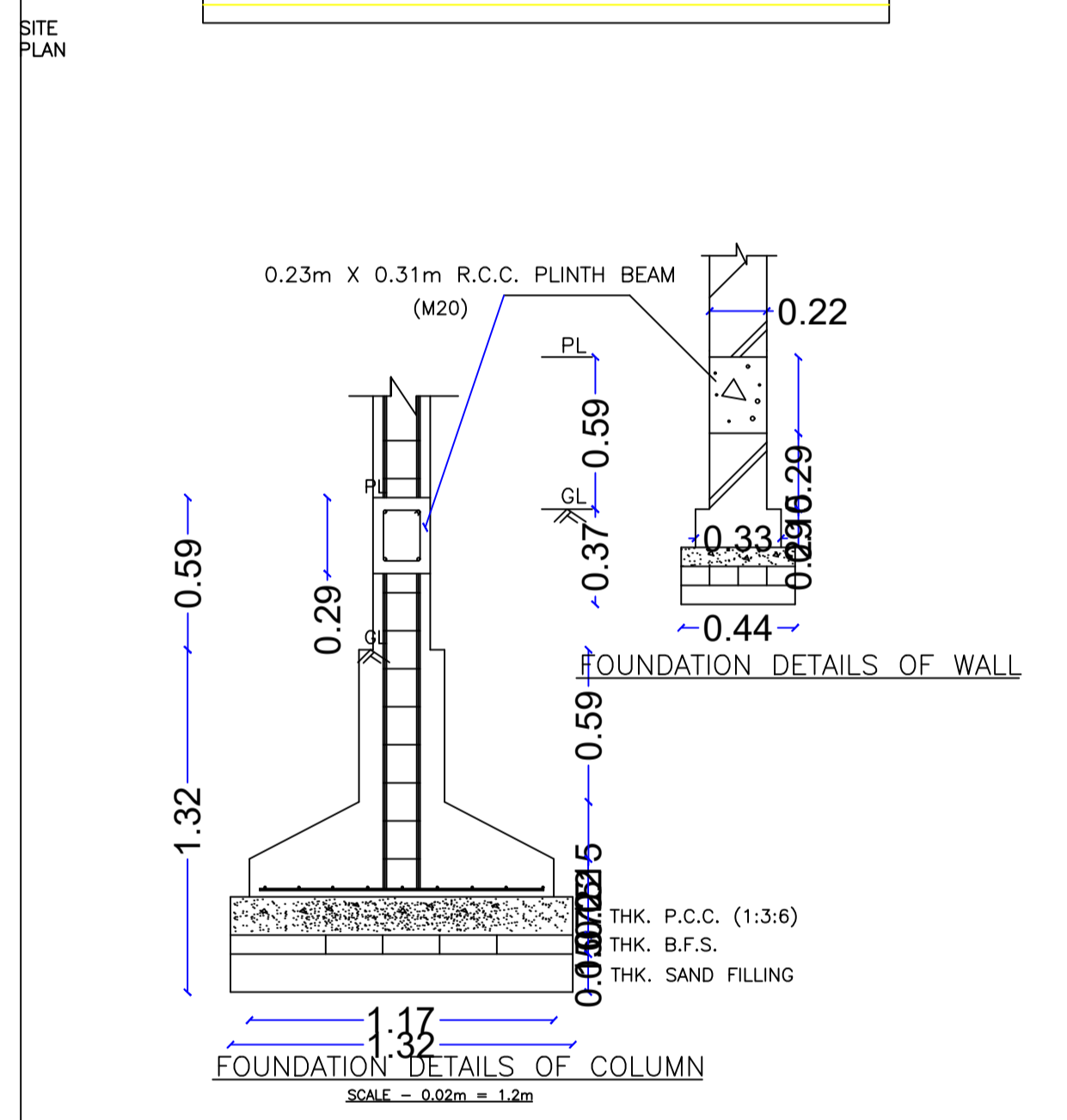
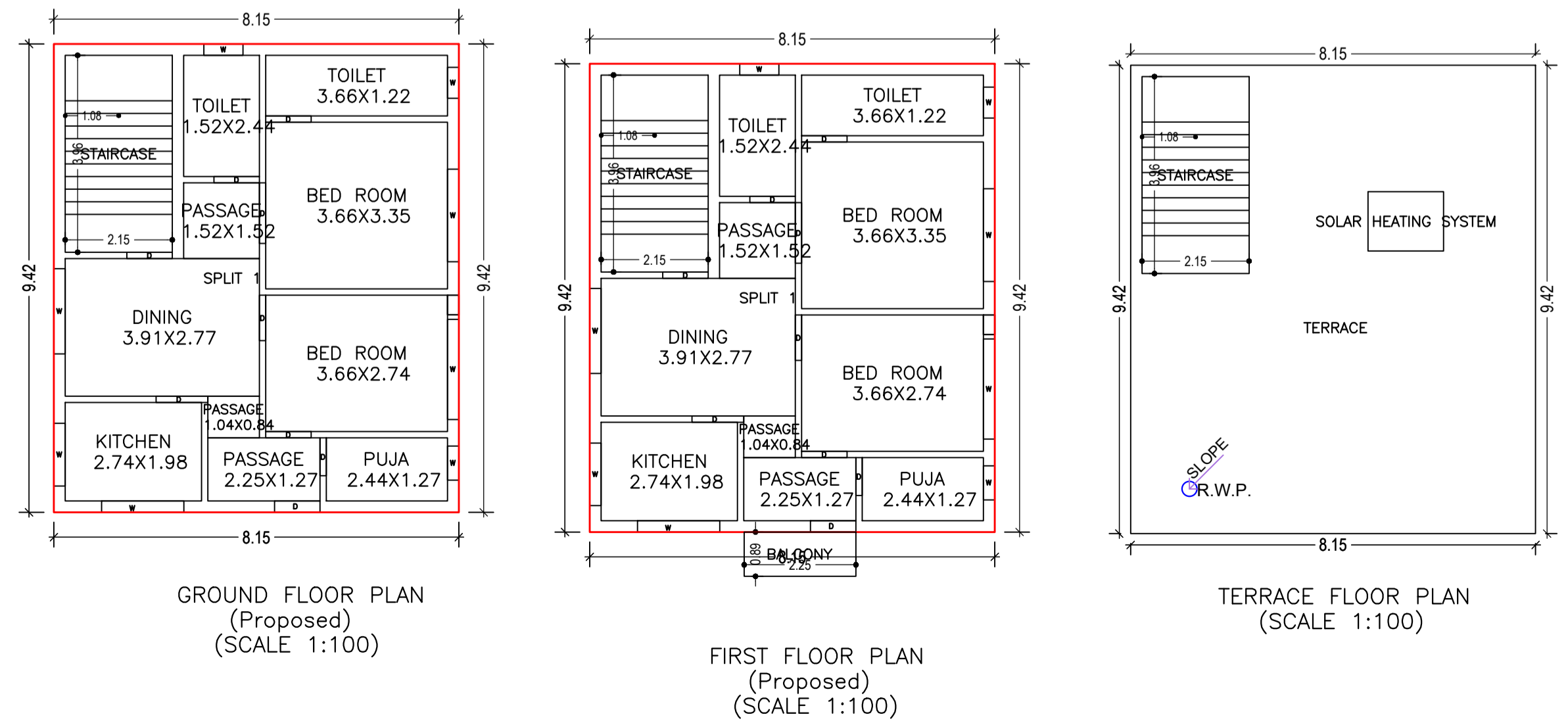

SCHEDULE OF DOOR:

BUILDING NAME	NAME	LENGTH	HEIGHT	NOS
A1 (A1)	D	0.76	2.10	02
A1 (A1)	D	0.91	2.10	12
A1 (A1)	D	1.04	2.10	02
A1 (A1)	D	1.22	2.10	02

SCHEDULE OF WINDOW/VENTILATION:

BUILDING NAME	NAME	LENGTH	HEIGHT	NOS
A1 (A1)	W	0.62	1.20	02
A1 (A1)	W	0.69	1.20	02
A1 (A1)	W	0.79	1.20	02
A1 (A1)	W	1.26	1.20	02
A1 (A1)	W	1.66	1.20	02
A1 (A1)	W	1.71	1.20	02
A1 (A1)	W	1.87	1.20	02
A1 (A1)	W	2.01	1.20	02

UnitBUA Table for Building :A1 (A1)

FLOOR	Name	UnitBUA Type	UnitBUA Area	Carpent Area	No. of Rooms	No. of Tenement
GROUND FLOOR PLAN	SPLIT 1	FLAT	155.55	153.37	10	1
FIRST FLOOR PLAN	SPLIT 1	FLAT	0.00	0.00	10	0
Total:	-	-	155.55	153.37	20	1

Balcony Calculations Table

FLOOR	SIZE	AREA	TOTAL AREA
FIRST FLOOR PLAN	0.89 X 2.25 X 1 X 1	2.00	2.00
Total	-	-	2.00

Building :A1 (A1)

Floor Name	Total Built Up Area (Sq.mt.)	Deductions (Area in Sq.mt.)	Proposed FAR Area (Sq.mt.)	Total FAR Area (Sq.mt.)	Total Consumed Additional FAR Area (Sq.mt.)	Tnmt (No.)
Ground Floor	76.77	0.00	76.77	76.77	76.77	01
First Floor	78.77	1.00	77.77	77.77	77.77	00
Terrace Floor	0.00	0.00	0.00	0.00	0.00	00
Total:	155.54	1.00	154.54	154.54	154.54	01
Total Number of Same Buildings :	1					
Total:	155.54	1.00	154.54	154.54	154.54	01

Buildingwise Floor FAR Details

Floor Name	Building Name		Total	
	Proposed Built Up Area (Sq.mt.)	Proposed FAR Area (Sq.mt.)	Total Proposed Built Up Area (Sq.mt.)	Total FAR Area (Sq.mt.)
Ground Floor	76.77	76.77	76.77	76.77
First Floor	78.77	77.77	78.77	77.77
Terrace Floor	0.00	0.00	0.00	0.00
Total :	155.54	154.54	155.54	154.54

Building USE/SUBUSE Details

Building Name	Building Use	Building SubUse	Building Structure
A1 (A1)	Residential	Bungalow/ Dwelling / Non Apartment	Non-Highrise

FAR & Tenement Details (Table 4c-1)

Building	No. of Same Bldg	Total Built Up Area (Sq.mt.)	Deductions (Area in Sq.mt.)	Proposed FAR Area (Sq.mt.)	Total FAR Area (Sq.mt.)	Total Consumed Additional FAR Area (Sq.mt.)	Tnmt (No.)
A1 (A1)	1	155.54	1.00	154.54	154.54	154.54	01
Grand Total:	1	155.54	1.00	154.54	154.54	154.54	01

LTP NAME AND SIGNATURE	STRUCTURAL ENG'S NAME AND SIGNATURE	BUILDER NAME AND SIGNATURE	DIGITAL SIGNATURE
AMIT KUMAR MADA/ENG/0008/2021			