

Proposal Basic Information	
Proposal File No.	MADA/BP/0364/2023
Owner Name	RAJA KUMAR
Khata No	61(OLD), 226(NEW)
Plot No	2781,2783(OLD), 1053,1055(NEW)
Village Name	Sijua
Use	Residential
SubUse	Bungalow/ Dwelling / Non Apartment

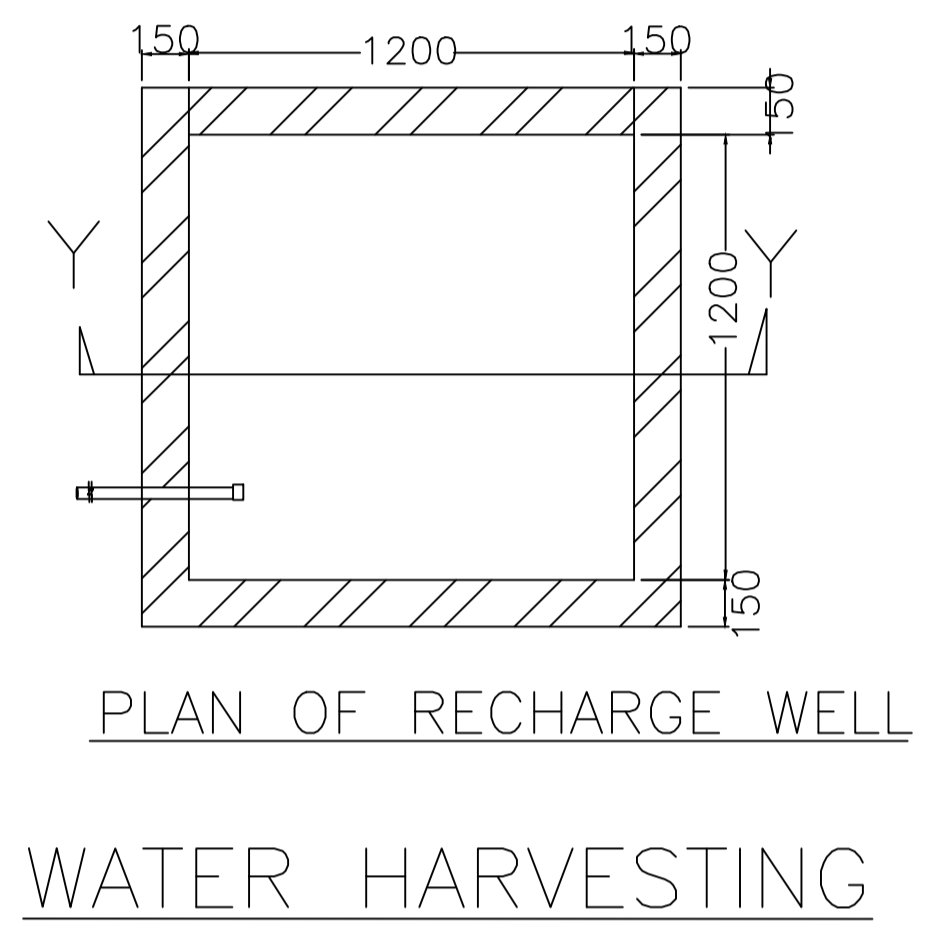
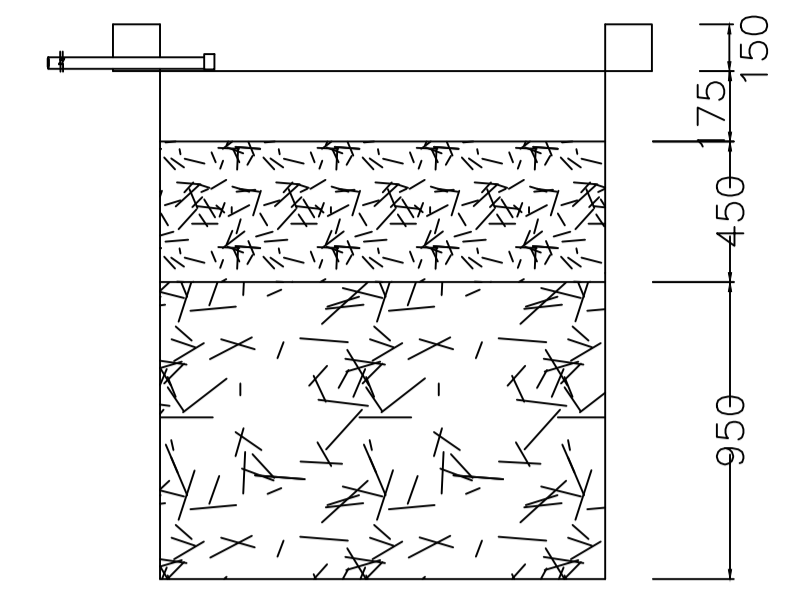
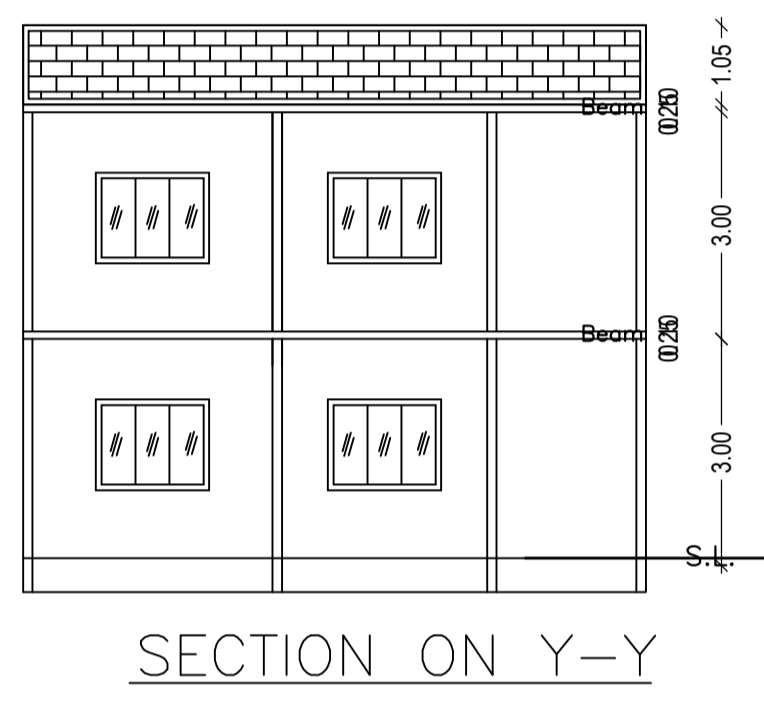
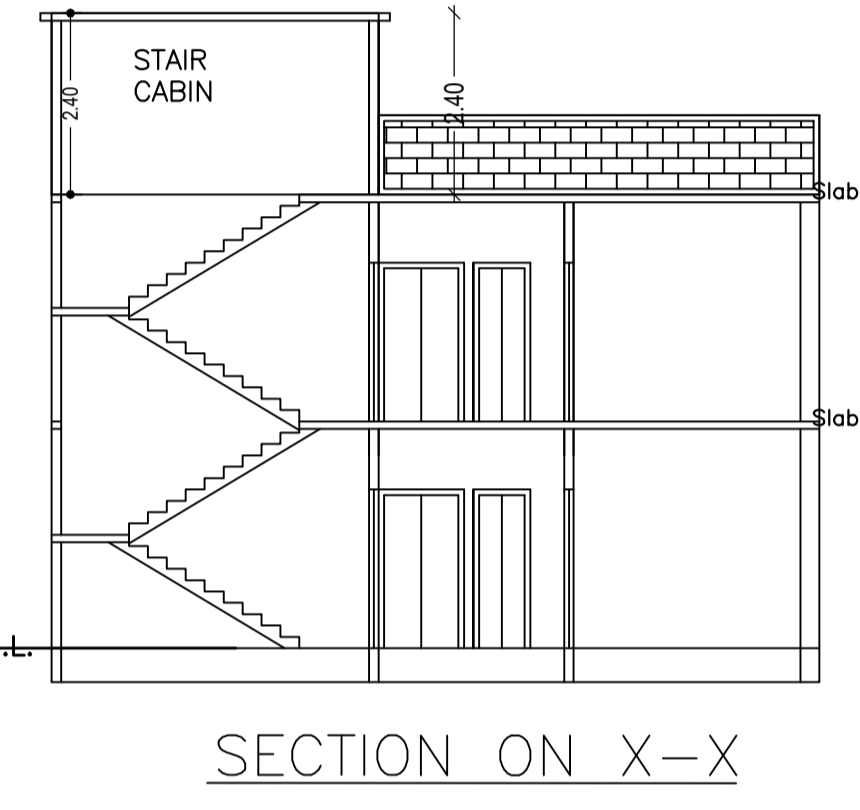
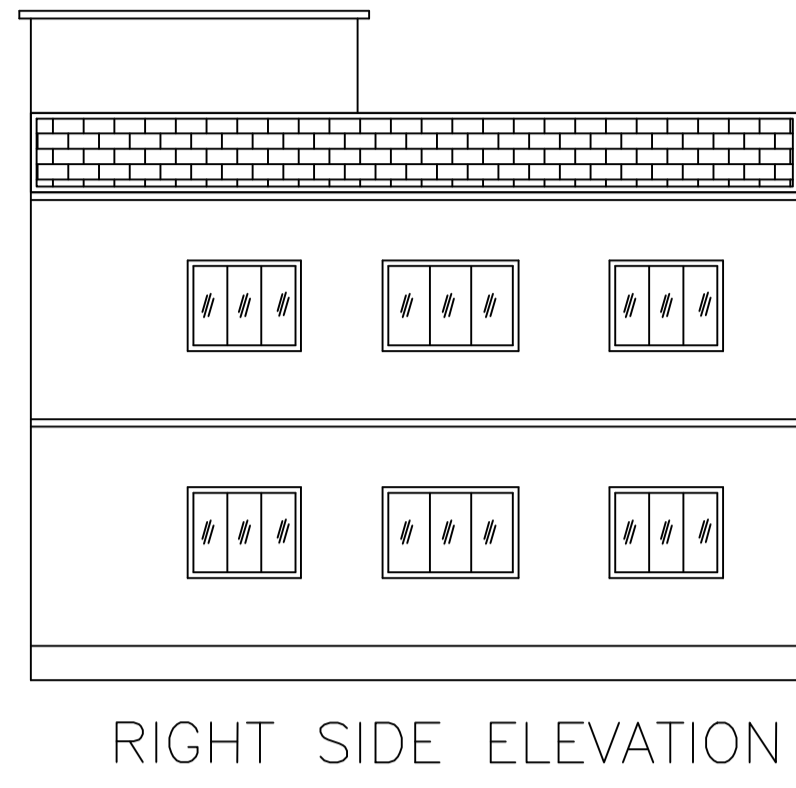
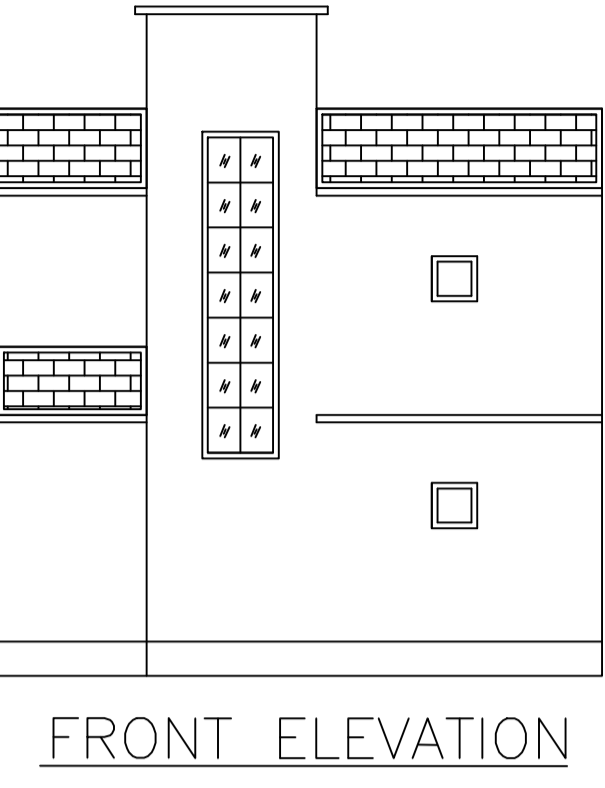
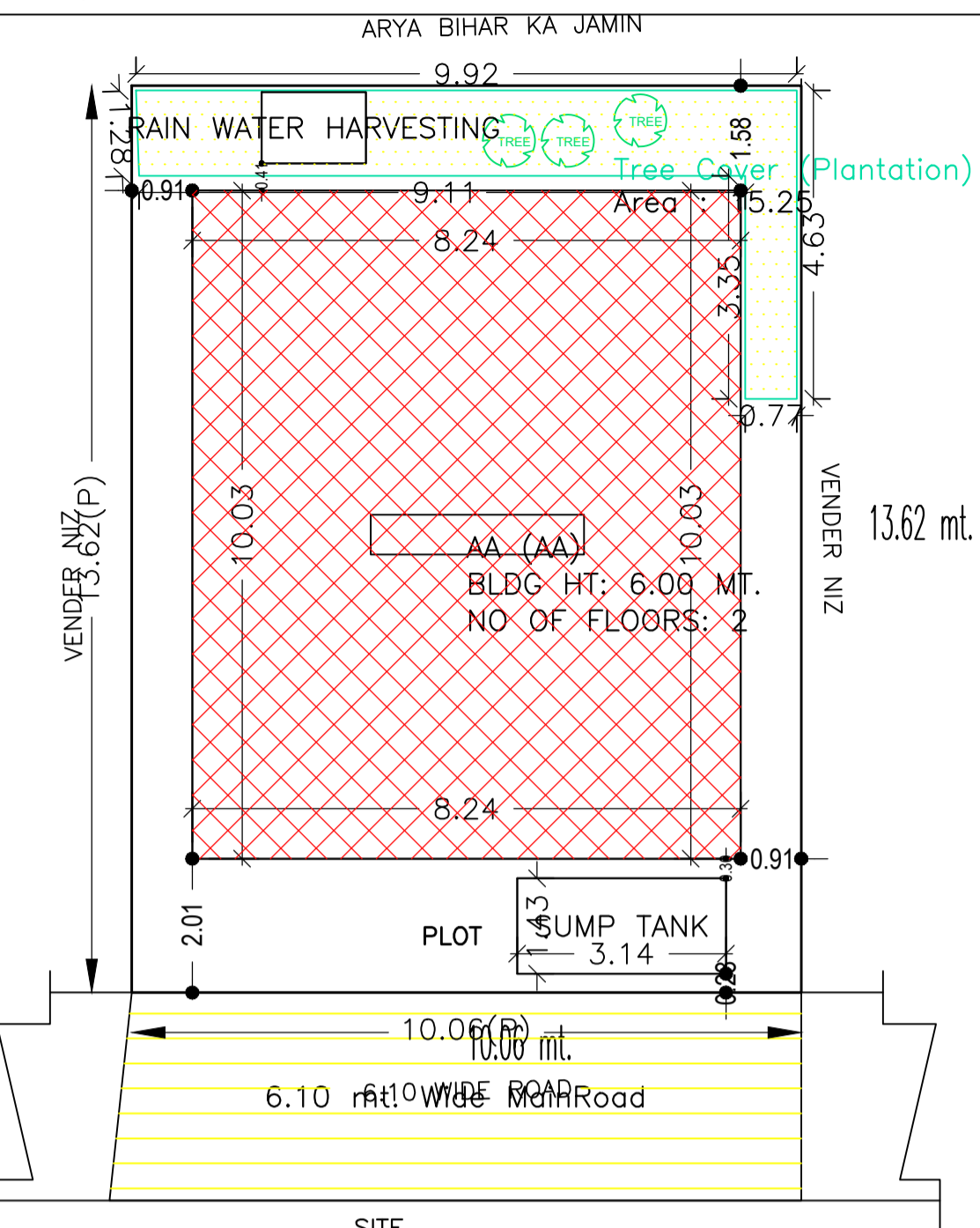

AREA STATEMENT MINERAL AREA DEVELOPMENT AUTHORITY		VERSION NO. : 1.0.66
PROJECT DETAIL:		VERSION DATE: 16/10/2020
Region: JHARKHAND URBAN LOCAL BODIES	Plot Use: Residential	
District: DHANBAD	Plot SubUse: Bungalow/ Dwelling / Non Apartment	
Authority: MINERAL AREA DEVELOPMENT AUTHORITY	PlotNearbyReligiousStructure: NA	
Inward No: MADA/BP/0364/2023	Plot/SubPlot No: 2781,2783(OLD), 1053,1055(NEW)	
Application Type: General Proposal	North: Plot No. - VENDER NIZ	
Project Type: Building Permission	South: Plot No. - VENDER NIZ	
Nature of Development: New	East: Plot No. - ARYA BIHAR KA JAMIN	
Location of Development Area: Old Area	West: Road Width - 6.10 WIDE ROAD	
AREA DETAILS:		SQ.MT.
AREA OF PLOT (Minimum)	(A)	136.96
NET AREA OF PLOT(Gross Plot Area - Deduction from Gross Plot area)	(A-Deductions)	136.96
Deduction for Balance Plot Area(from Gross Plot Area)		
Common Plot		15.25
Total		15.25
BALANCE AREA OF PLOT(Net Plot Area - Recreational/Amenity spaces)	(A-Deductions)	121.70
PLOT AREA FOR COVERAGE(Net Plot Area)	(A-Deductions)	136.96
Plot Area for FAR (Net Plot Area + RoadWidening Area)	(A-Deductions)	136.96
COVERAGE CHECK		
Permissible Coverage area ( 70.00 % )		95.87
Proposed Coverage Area ( 60.34 % )		82.64
Total Prop. Coverage Area ( 60.34 % )		82.64
Balance coverage area ( 9.66 % )		13.23
FAR CHECK		
Perm. FAR Area ( 2.500 )		342.40
Total Perm. FAR area		342.40
Residential FAR		165.28
Proposed FAR Area		165.28
Total Proposed FAR Area		165.28
Consumed FAR (Factor)		1.21
Balance FAR Area		177.12
BUILT UP AREA CHECK		
Total Proposed BuiltUp Area		165.28
ARCHITECT (Regd)		SANJEEV KUMAR RAY
ENGINEER (Regd)		
SUPERVISOR (Regd)		
OWNER (Regd)		RAJA KUMAR
DEVELOPMENT AUTHORITY		LOCAL BODY

FAR & Tenement Details (Table 4c-1)

Building	No. of Same Bldg	Total Built Up Area (Sq.mt.)	Proposed FAR Area (Sq.mt.) Resi.	Total FAR Area (Sq.mt.)	Total Consumed Additional FAR Area (Sq.mt.)	Tnmt (No.)
AA (AA)	1	165.28	165.28	165.28	165.28	01
Grand Total :	1	165.28	165.28	165.28	165.28	01

Building :AA (AA)

Floor Name	Total Built Up Area (Sq.mt.)	Proposed FAR Area (Sq.mt.) Resi.	Total FAR Area (Sq.mt.)	Total Consumed Additional FAR Area (Sq.mt.)	Tnmt (No.)
Ground Floor	82.64	82.64	82.64	82.64	01
First Floor	82.64	82.64	82.64	82.64	00
Terrace Floor	0.00	0.00	0.00	0.00	00
Total	165.28	165.28	165.28	165.28	01
Total Number of Same Buildings :	1				
Total :	165.28	165.28	165.28	165.28	01

SCHEDULE OF DOOR:

BUILDING NAME	NAME	LENGTH	HEIGHT	NOS
AA (AA)	D3	0.75	2.10	02
AA (AA)	D2	0.90	2.10	02
AA (AA)	D1	0.96	2.10	02
AA (AA)	D1	1.05	2.10	04
AA (AA)	D3	1.05	2.10	02
AA (AA)	D	1.13	2.10	02
AA (AA)	D1	1.13	2.10	02

SCHEDULE OF WINDOW/VENTILATION:

BUILDING NAME	NAME	LENGTH	HEIGHT	NOS
AA (AA)	V	0.60	1.20	04
AA (AA)	W1	0.90	1.20	02
AA (AA)	W	1.50	1.20	10
AA (AA)	W	1.80	1.20	02

UnitBUA Table for Building :AA (AA)

FLOOR	Name	UnitBUA Type	UnitBUA Area	Carpet Area	No. of Rooms	No. of Tenement
GROUND FLOOR PLAN	SPLIT AA	FLAT	165.28	165.19	8	1
FIRST FLOOR PLAN	SPLIT AA	FLAT	0.00	0.00	8	0
Total:	-	-	165.28	165.19	16	1

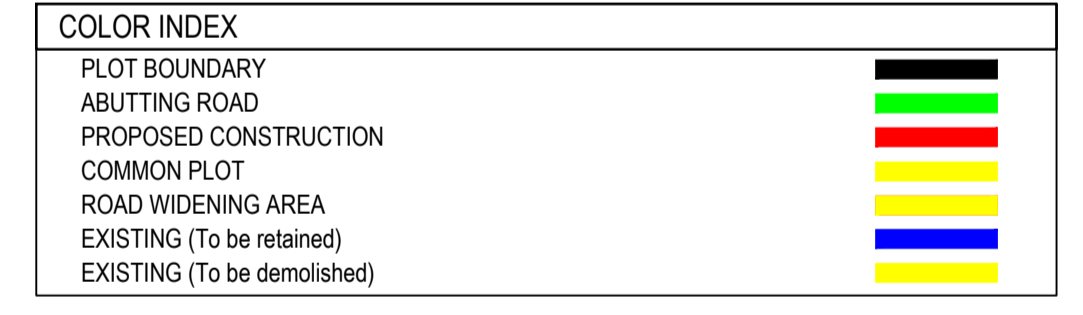

Buildingwise Floor FAR Details

Floor Name	Building Name		Total	
	Proposed Built Up Area (Sq.mt.)	Proposed FAR Area (Sq.mt.)	Total Proposed Built Up Area (Sq.mt.)	Total FAR Area (Sq.mt.)
Ground Floor	82.64	82.64	82.64	82.64
First Floor	82.64	82.64	82.64	82.64
Terrace Floor	0.00	0.00	0.00	0.00
Total :	165.28	165.28	165.28	165.28

Building USE/SUBUSE Details

Building Name	Building Use	Building SubUse	Building Structure
AA (AA)	Residential	Bungalow/ Dwelling / Non Apartment	Non-Highrise

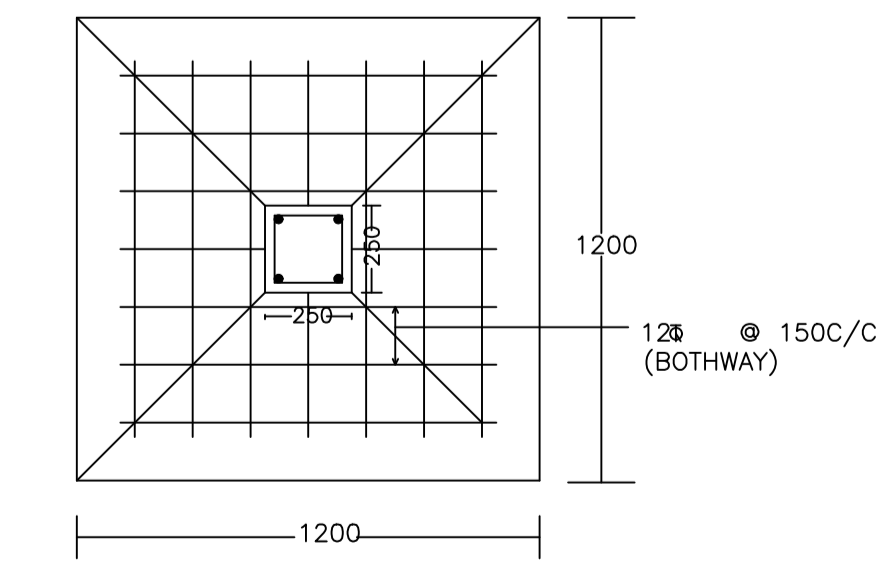
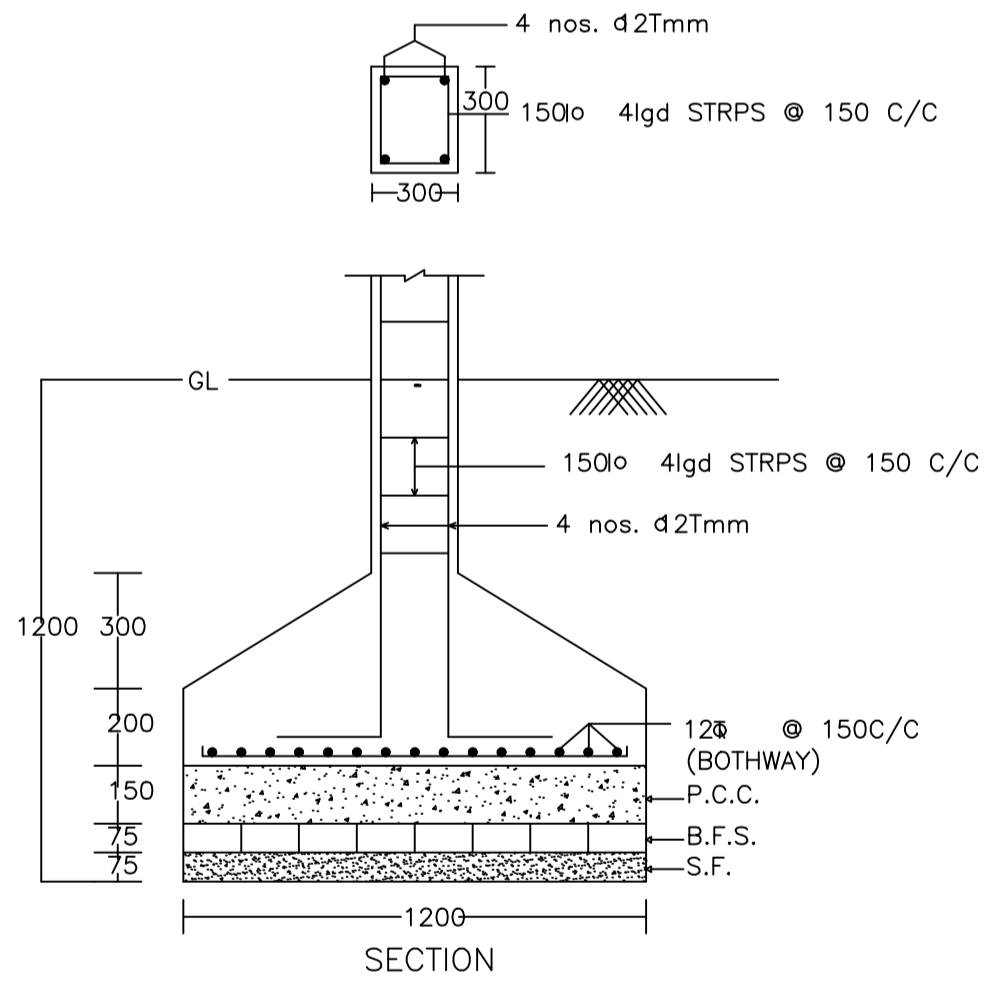
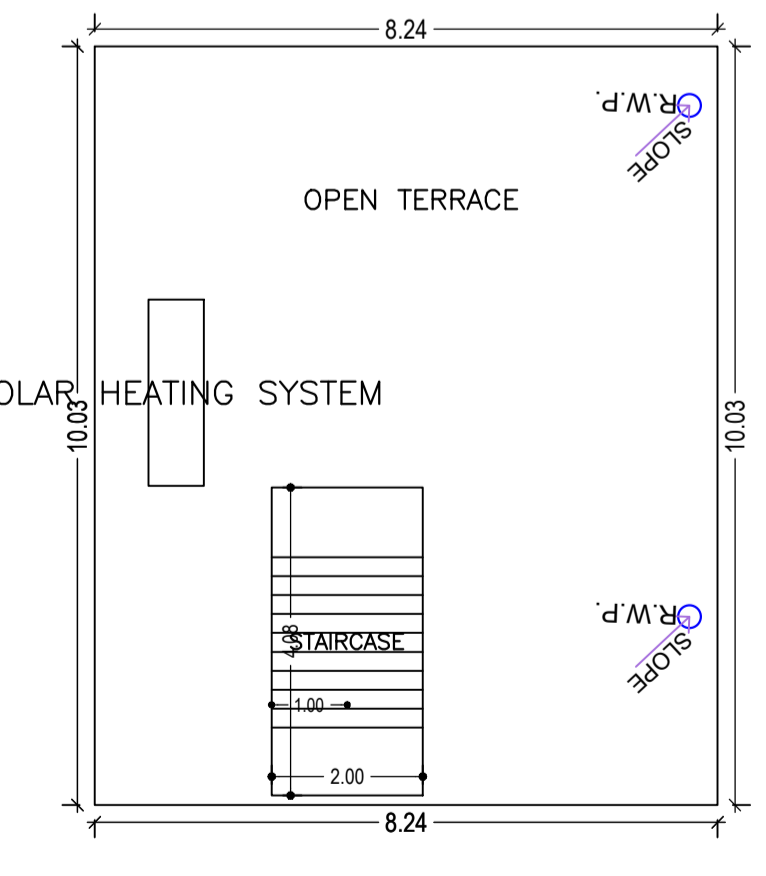
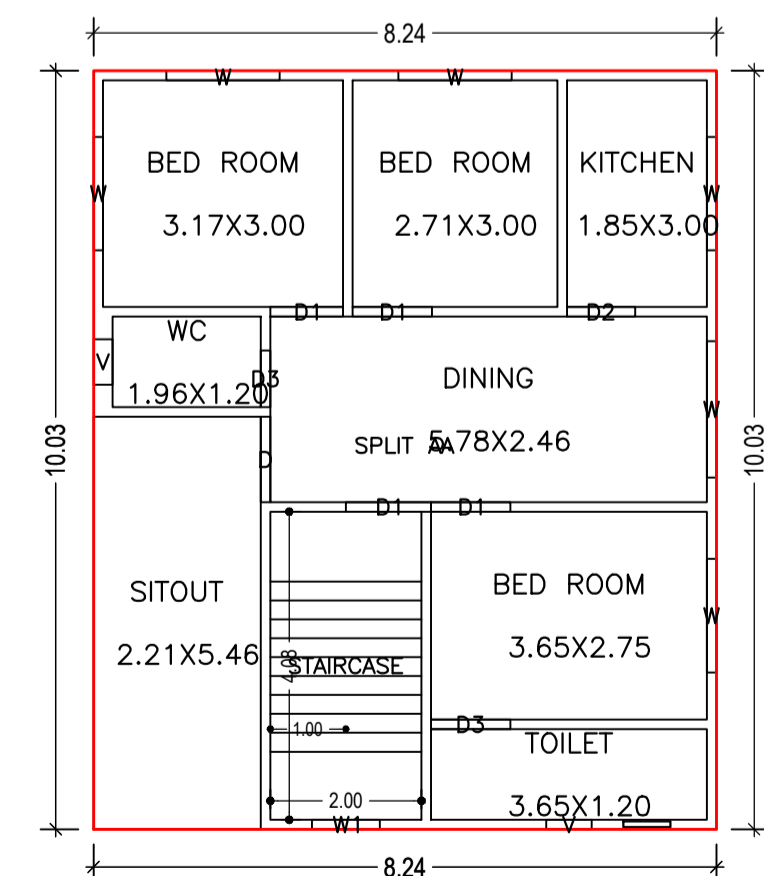
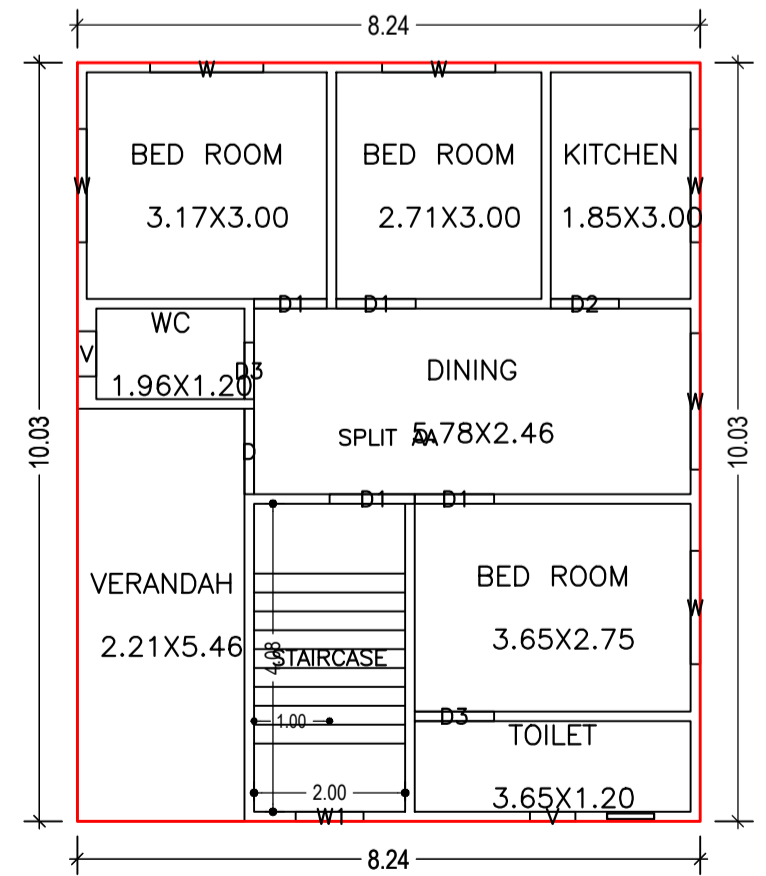

DETAIL OF COLUMNS

LTP NAME AND SIGNATURE	STRUCTURAL ENG'S NAME AND SIGNATURE	BUILDER NAME AND SIGNATURE	DIGITAL SIGNATURE
SANJEEV KUMAR RAY MADA/ENG/0021/2019			