

SITE PLAN

AREA STATEMENT MINERAL AREA DEVELOPMENT AUTHORITY	VERSION NO.: 1.0.66		
PROJECT DETAIL:	VERSION DATE: 16/10/2020		
Region : JHARKHAND URBAN LOCAL BODIES	Plot Use: Residential		
District : DHANBAD	Plot SubUse: Bungalow/ Dwelling / Non Apartment		
Authority: MINERAL AREA DEVELOPMENT AUTHORITY	PlotNearbyReligiousStructure: NA		
Inward No: MADA/BP/0347/2023	Plot/SubPlot No: OLD PLOT NO-515, NEW PLOT NO-1458		
Application Type: General Proposal	North: Plot No. - SAME PLOT		
Project Type: Building Permission	South: Plot No. - SAME PLOT		
Nature of Development: New	East: Road Width - 6.10		
Location of Development Area: Old Area	West: Plot No. - SAME PLOT		
AREA DETAILS:			
AREA OF PLOT (Minimum)	(A)	SQ.MT.	92.80
NET AREA OF PLOT(Gross Plot Area - Deduction from Gross Plot area)	(A-Deductions)		92.80
Deduction for Balance Plot Area(from Gross Plot Area)			
Common Plot		10.01	
Total		10.01	
BALANCE AREA OF PLOT(Net Plot Area - Recreational/Amenity space)	(A-Deductions)		82.78
PLOT AREA FOR COVERAGE(Net Plot Area)	(A-Deductions)		92.80
Plot Area for FAR (Net Plot Area + RoadWidening Area)	(A-Deductions)		92.80
COVERAGE CHECK			
Permissible Coverage area (70.00 %)			64.96
Proposed Coverage Area (62.67 %)			58.16
Total Prop. Coverage Area (62.67 %)			58.16
Balance coverage area (7.33 %)			6.80
FAR CHECK			
Perm. FAR Area (2.500)			232.00
Total Perm. FAR area			232.00
Residential FAR			116.31
Proposed FAR Area			116.31
Total Proposed FAR Area			116.31
Consumed FAR (Factor)			1.25
Balance FAR Area			115.69
BUILT UP AREA CHECK			
Total Proposed BuiltUp Area			116.32
ARCHITECT (Regd)			RAM PRATAP SINGH
ENGINEER (Regd)			
SUPERVISOR (Regd)			
OWNER (Regd)			SRI. KUMAR GAURAV
DEVELOPMENT AUTHORITY			LOCAL BODY

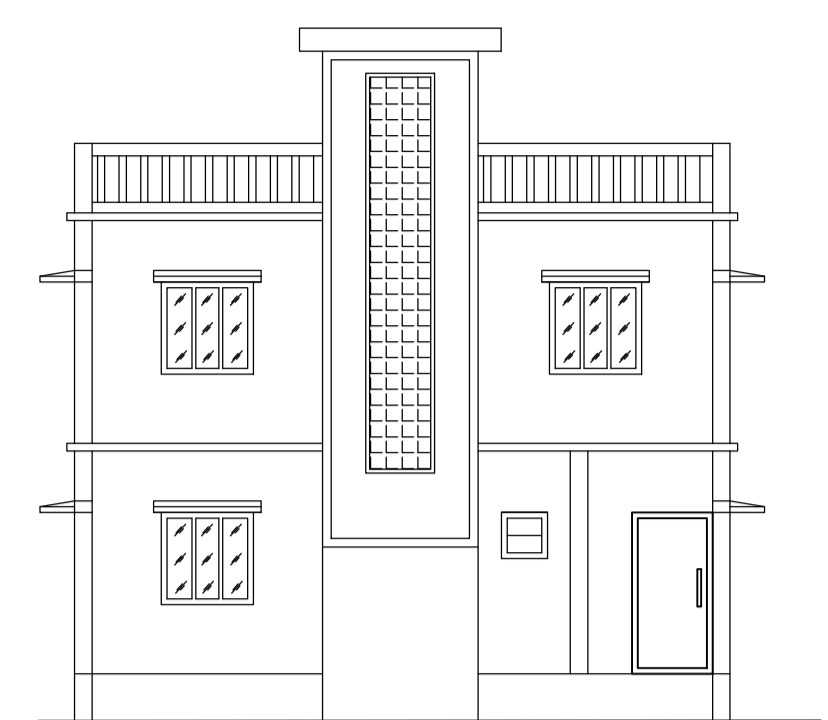

LEFT SIDE ELEVATION

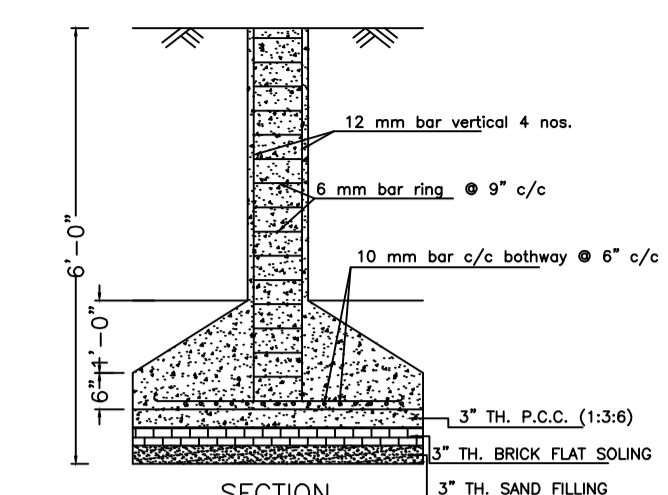

SECTION

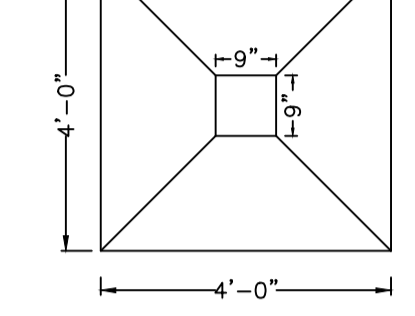

PLAN

DETAILS OF COLUMN FOUNDATION

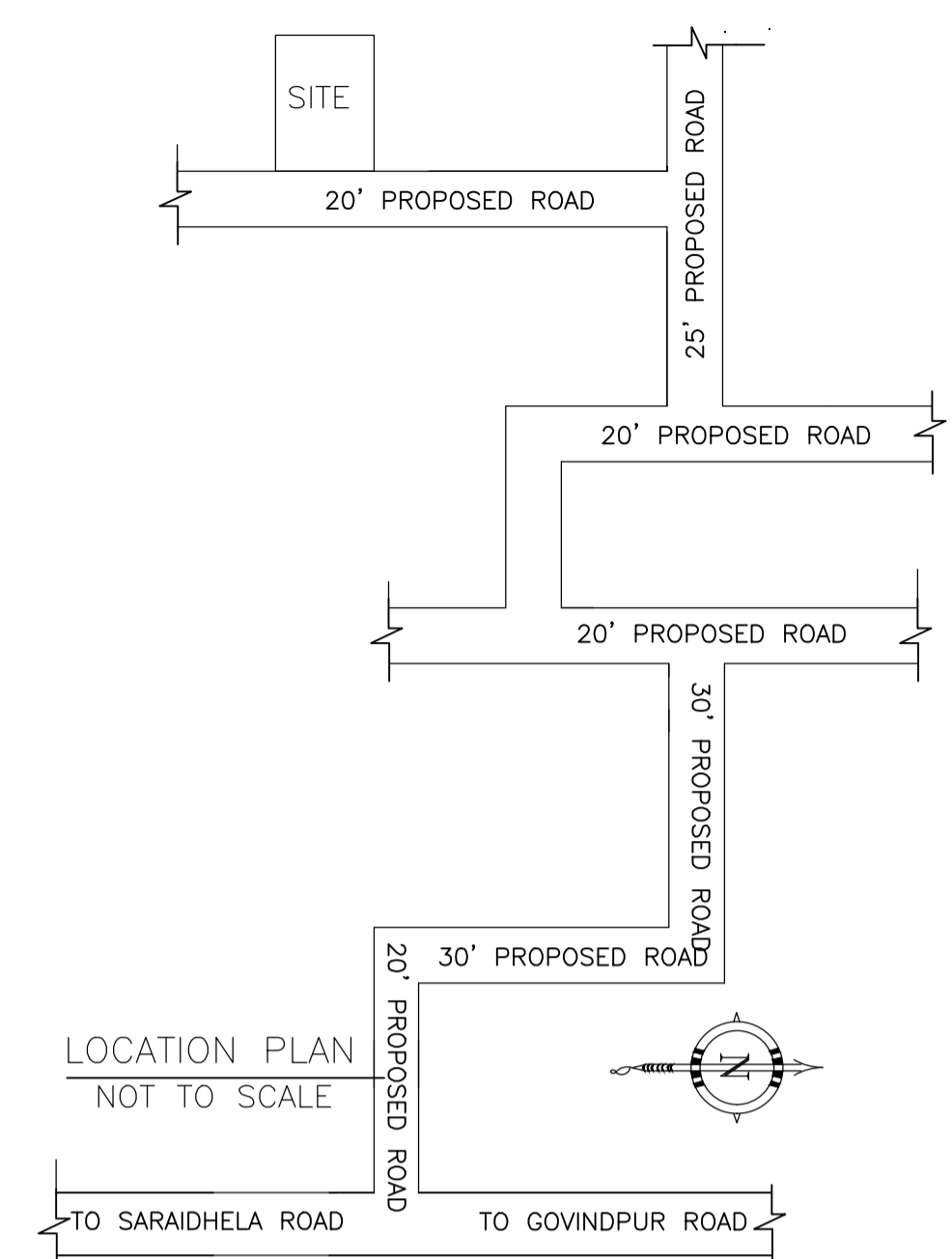

LOCATION PLAN NOT TO SCALE

Proposal Basic Information	
Proposal File No.	MADA/BP/0347/2023
Owner Name	SRI. KUMAR GAURAV
Khata No	OLD KHATA NO-34, NEW KHATA NO-5
Plot No	OLD PLOT NO-515, NEW PLOT NO-1458
Village Name	Jialgora
Use	Residential
SubUse	Bungalow/ Dwelling / Non Apartment

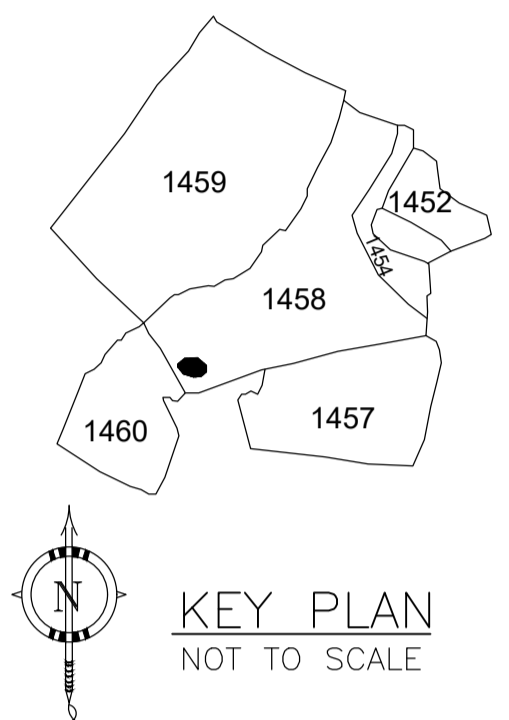

KEY PLAN NOT TO SCALE

FAR & Tenement Details (Table 4c-1)

Building	No. of Same Bldg	Total Built Up Area (Sq.mt.)	Proposed FAR Area (Sq.mt.) Res.	Total FAR Area (Sq.mt.)	Total Consumed Additional FAR Area (Sq.mt.)	Tnmt (No.)
A (KUMAR GAURAV)	1	116.32	116.32	116.32	116.32	01
Grand Total :	1	116.32	116.32	116.32	116.32	01

Buildingwise Floor FAR Details

Floor Name	Building Name A (KUMAR GAURAV)		Total	
	Proposed Built Up Area (Sq.mt.)	Proposed FAR Area (Sq.mt.)	Total Proposed Built Up Area (Sq.mt.)	Total FAR Area (Sq.mt.)
Ground Floor	58.16	58.16	58.16	58.16
First Floor	58.16	58.16	58.16	58.16
Terrace Floor	0.00	0.00	0.00	0.00
Total :	116.32	116.32	116.32	116.32

Building USE/SUBUSE Details

Building Name	Building Use	Building SubUse	Building Structure
A (KUMAR GAURAV)	Residential	Bungalow/ Dwelling / Non Apartment	Non-Highrise

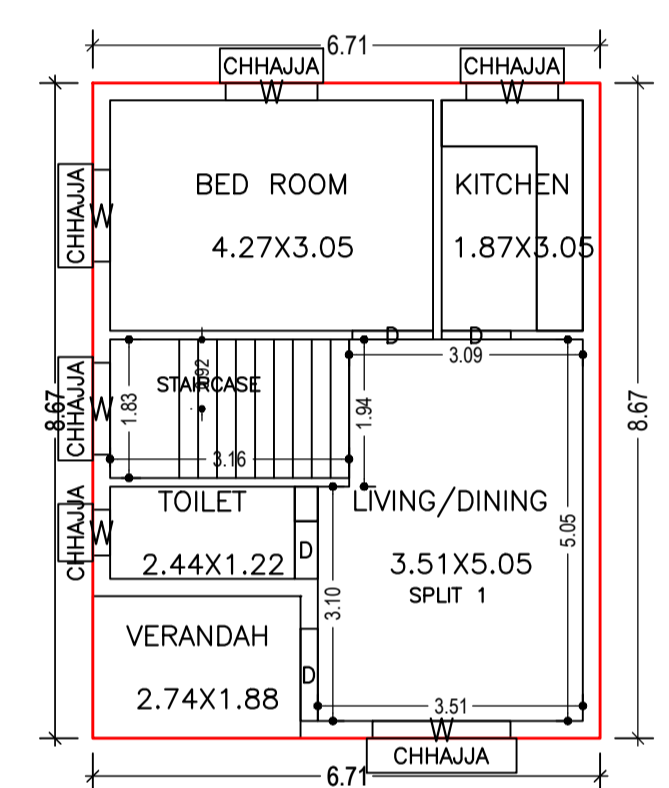

GROUND FLOOR PLAN (Proposed)

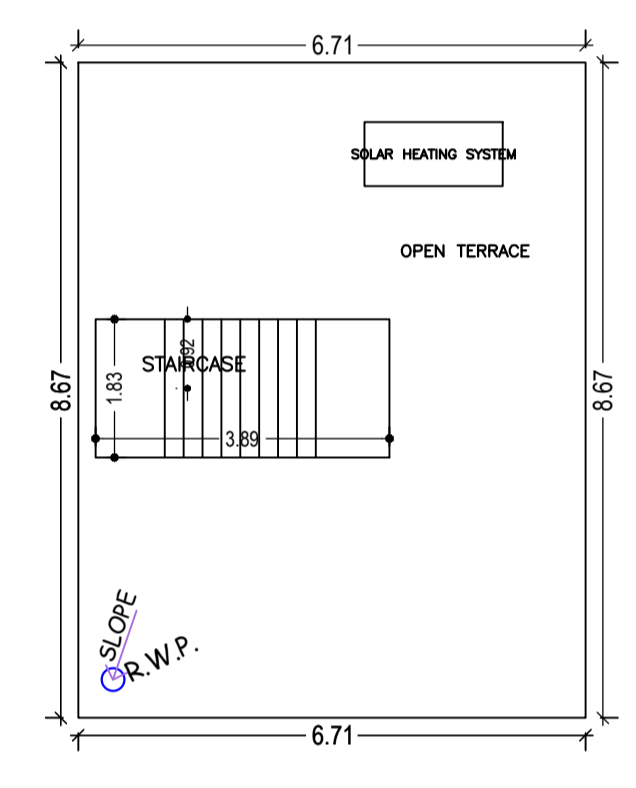

TERRACE FLOOR PLAN (SCALE 1:100)

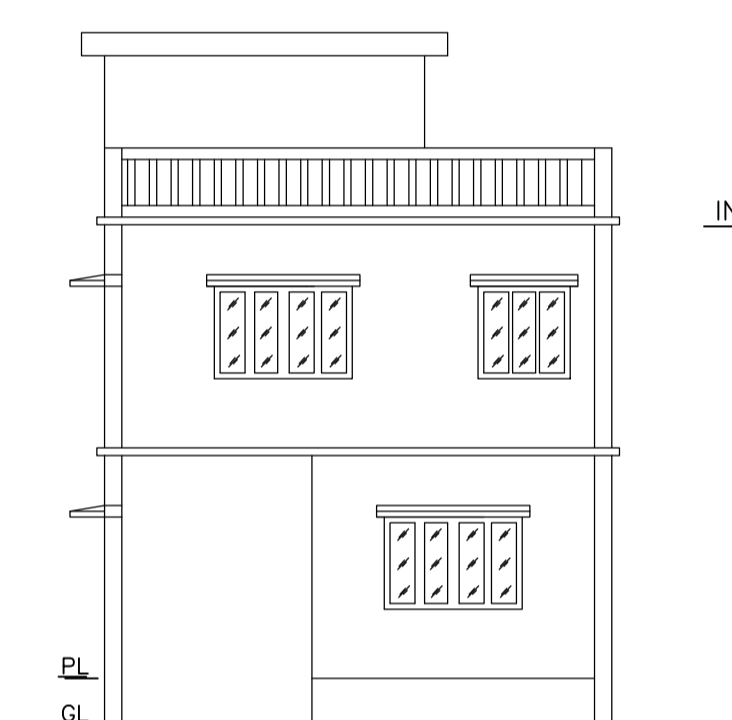

FRONT ELEVATION

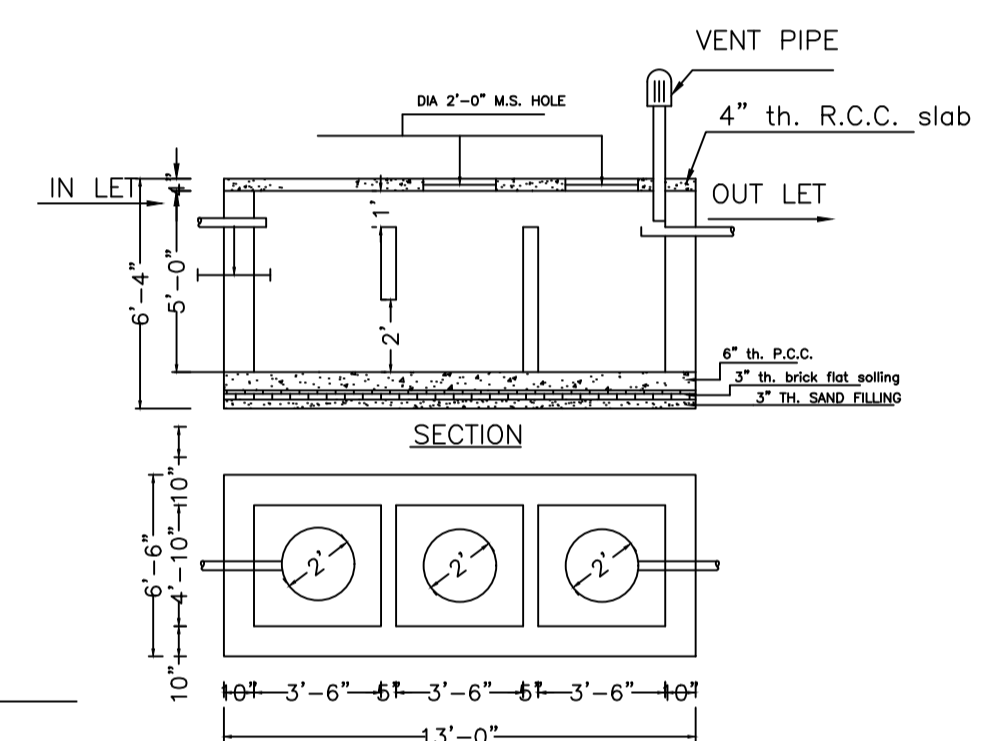

DETAILS OF SEPTIC TANK

(SCALE 1:100)

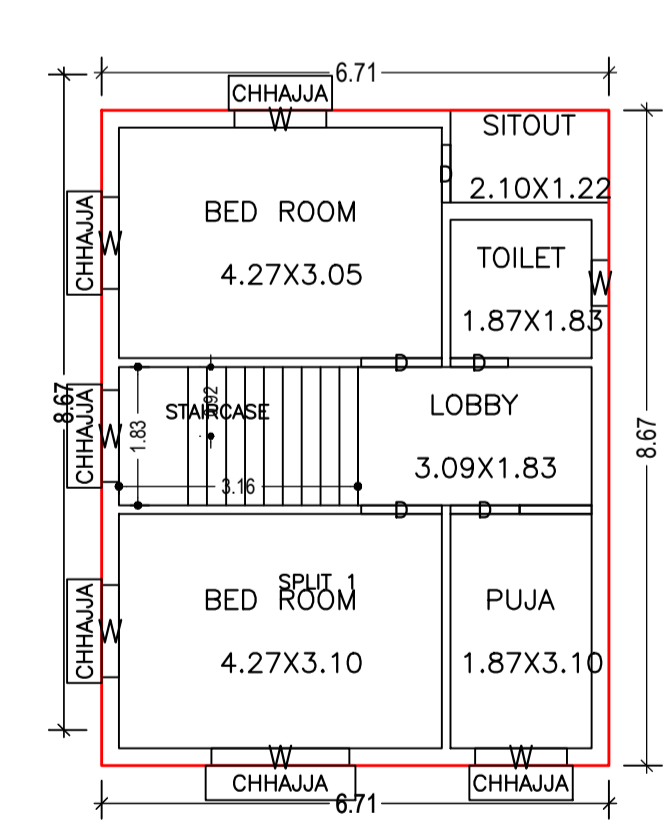

FIRST FLOOR PLAN (Proposed) (SCALE 1:100)

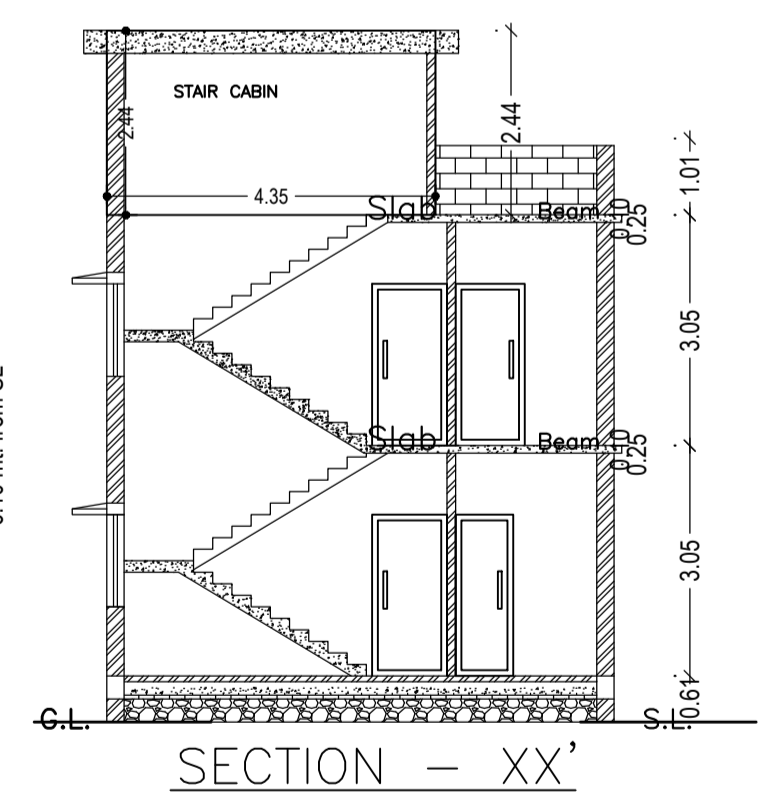

SECTION - XX'

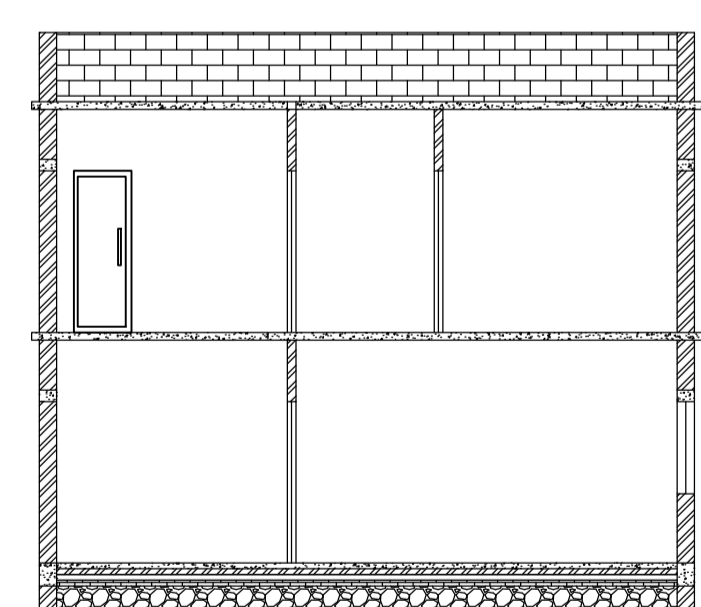

SECTION - YY'

SCHEDULE OF DOOR:

BUILDING NAME	NAME	LENGTH	HEIGHT	NOS
A (KUMAR GAURAV)	D	0.76	2.10	03
A (KUMAR GAURAV)	D	0.92	2.10	02
A (KUMAR GAURAV)	D	1.07	2.10	03
A (KUMAR GAURAV)	D	1.22	2.10	01

SCHEDULE OF WINDOW/VENTILATION:

BUILDING NAME	NAME	LENGTH	HEIGHT	NOS
A (KUMAR GAURAV)	W	0.61	1.20	02
A (KUMAR GAURAV)	W	1.22	1.20	09
A (KUMAR GAURAV)	W	1.83	1.20	02

UnitBUA Table for Building :A (KUMAR GAURAV)

FLOOR	Name	UnitBUA Type	UnitBUA Area	Carpet Area	No. of Rooms	No. of Tenement
GROUND FLOOR PLAN	SPLIT 1	FLAT	116.31	113.44	5	1
FIRST FLOOR PLAN	SPLIT 1	FLAT	0.00	0.00	6	0
Total:	-	-	116.31	113.44	11	1

COLOR INDEX	
PLOT BOUNDARY	Black
ABUTTING ROAD	Green
PROPOSED CONSTRUCTION	Red
COMMON PLOT	Blue
ROAD WIDENING AREA	Yellow
EXISTING (To be retained)	Light Blue
EXISTING (To be demolished)	Light Yellow

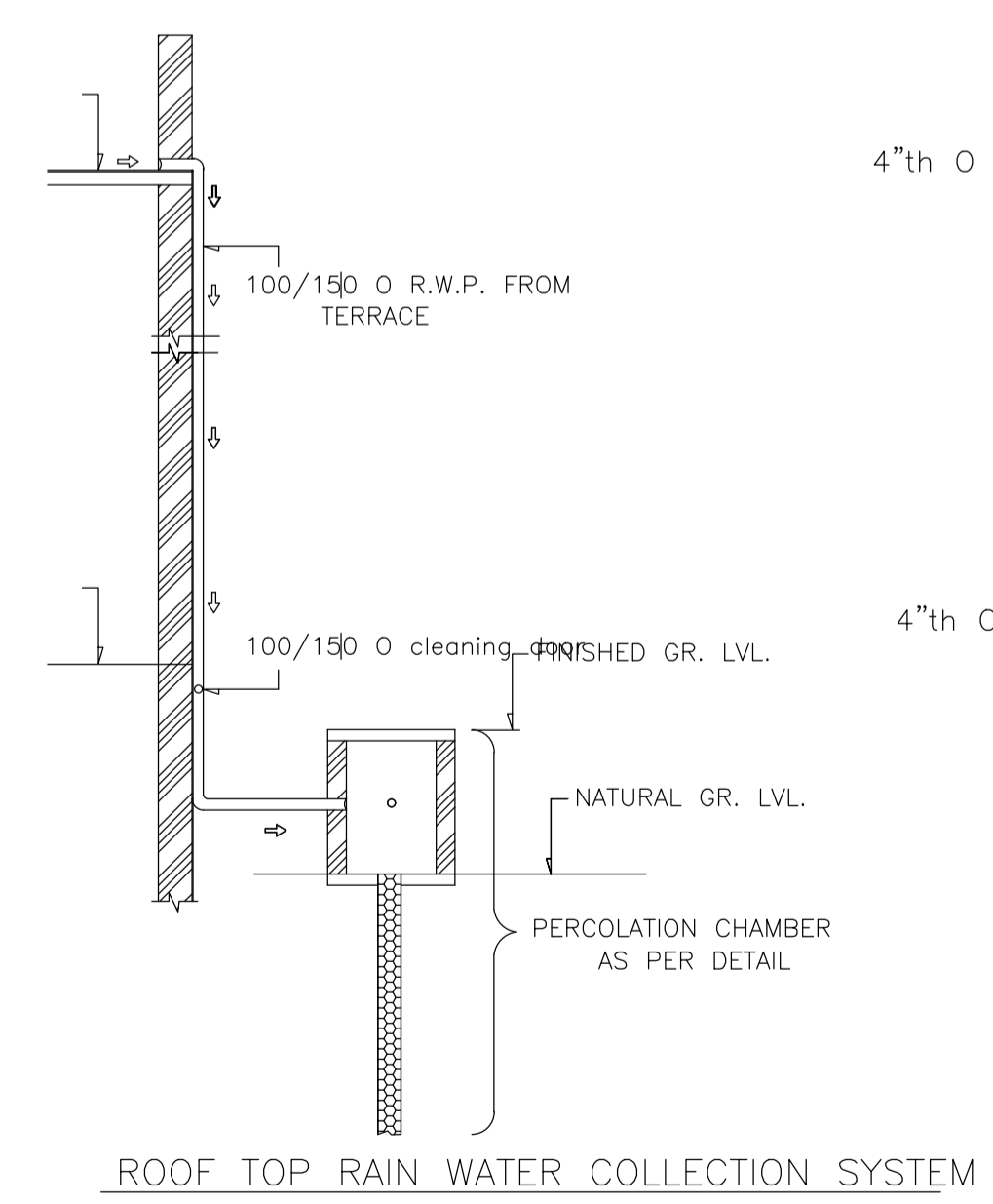

ROOF TOP RAIN WATER COLLECTION SYSTEM

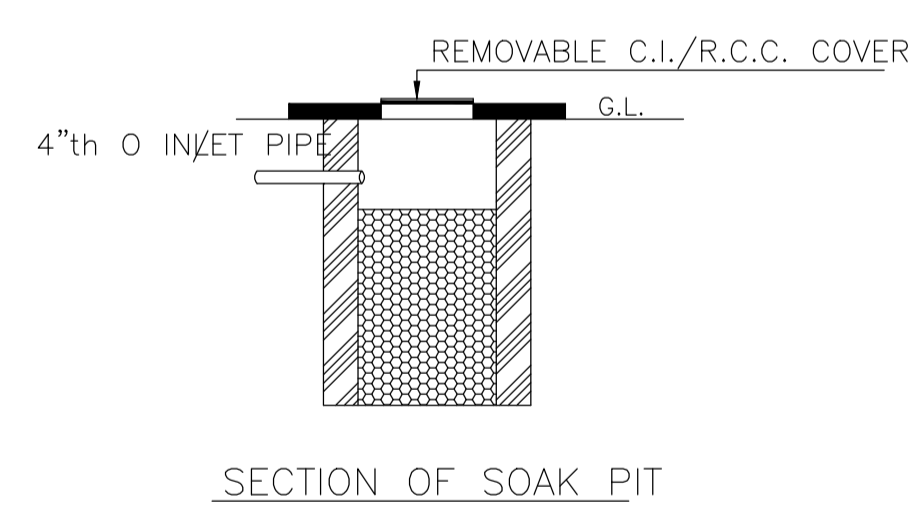

SECTION OF SOAK PIT

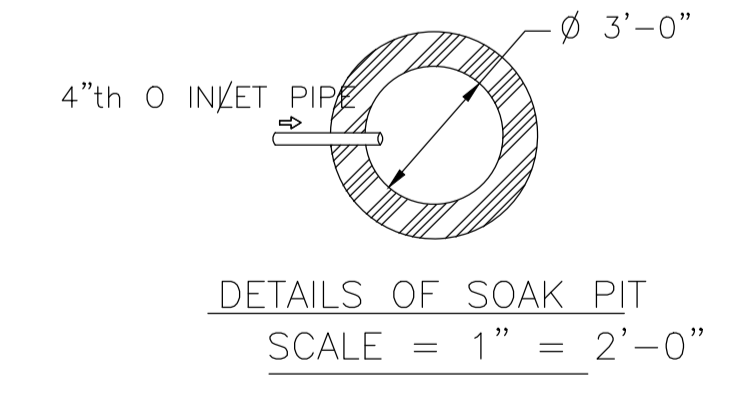

DETAILS OF SOAK PIT SCALE = 1" = 2'-0"

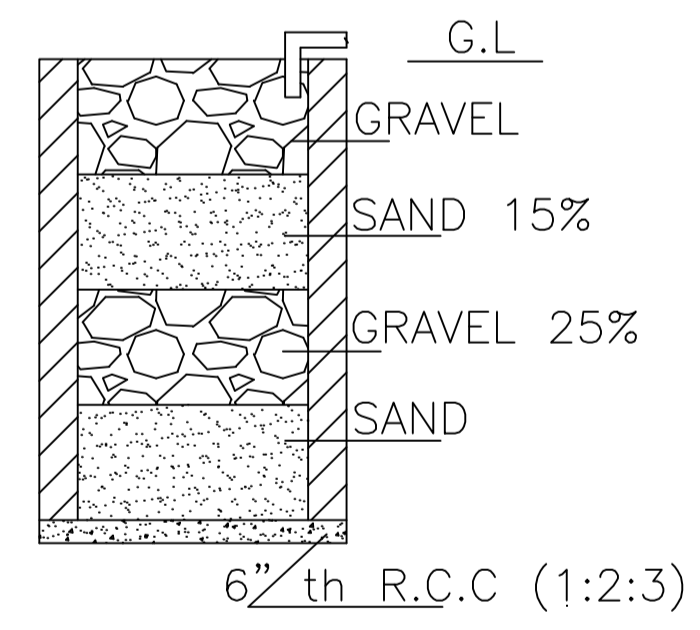

SECTION ON A - B

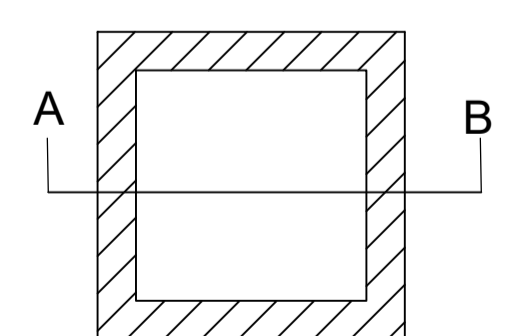

DETAILS DRAWING OF RAIN WATER HARVESTING

LTP NAME AND SIGNATURE	STRUCTURAL ENG'S NAME AND SIGNATURE	BUILDER NAME AND SIGNATURE	DIGITAL SIGNATURE
RAM PRATAP SINGH MADA/ARC/0024/2019			