

AREA STATEMENT MINERAL AREA DEVELOPMENT AUTHORITY	VERSION NO.: 1.0.66
PROJECT DETAIL:	VERSION DATE: 16/10/2020
Region: JHARKHAND URBAN LOCAL BODIES	Plot Use: Residential
District: DHANBAD	Plot SubUse: Bungalow/ Dwelling / Non Apartment
Authority: MINERAL AREA DEVELOPMENT AUTHORITY	PlotNearbyReligiousStructure: NA
Inward No: MADA/BP/0291/2023	Plot/SubPlot No: 671
Application Type: General Proposal	North: Plot No. - RAM CHANDA MAHTO
Project Type: Building Permission	South: Plot No. - ISWAR LAL VERMA
Nature of Development: New	East: Plot No. - BRAJESH KUMAR & KHUBLAL MAHTO
Location of Development Area: Old Area	West: Road Width - 3.65
AREA DETAILS:	SQ.MT.
AREA OF PLOT (Minimum)	113.52
Deduction for NetPlot Area	
Road Widening Area	13.43
Total	13.43
NET AREA OF PLOT(Gross Plot Area - Deduction from Gross Plot area)	100.08
Deduction for Balance Plot Area(from Gross Plot Area)	
Road Widening Area	13.43
Common Plot	11.13
Total	24.56
BALANCE AREA OF PLOT(Net Plot Area - Recreational/Amenity space)	88.96
PLOT AREA FOR COVERAGE(Net Plot Area)	100.08
Plot Area for FAR (Net Plot Area - RoadWidening Area)	100.08
COVERAGE CHECK	
Permissible Coverage area ( 70.00 % )	70.06
Proposed Coverage Area ( 55.73 % )	55.78
Total Prop. Coverage Area ( 55.73 % )	55.78
Balance coverage area ( 14.27 % )	14.28
FAR CHECK	
Perm. FAR Area ( 1.500 )	150.12
Total Perm. FAR area	150.12
Residential FAR	111.57
Proposed FAR Area	111.57
Total Proposed FAR Area	111.57
Consumed FAR (Factor)	1.11
Balance FAR Area	38.55
BUILT UP AREA CHECK	
Total Proposed BuiltUp Area	111.56
ARCHITECT (Regd)	SANTOSH
ENGINEER (Regd)	
SUPERVISOR (Regd)	
OWNER (Regd)	SMT. KAUSHALYA DEVI
DEVELOPMENT AUTHORITY	LOCAL BODY

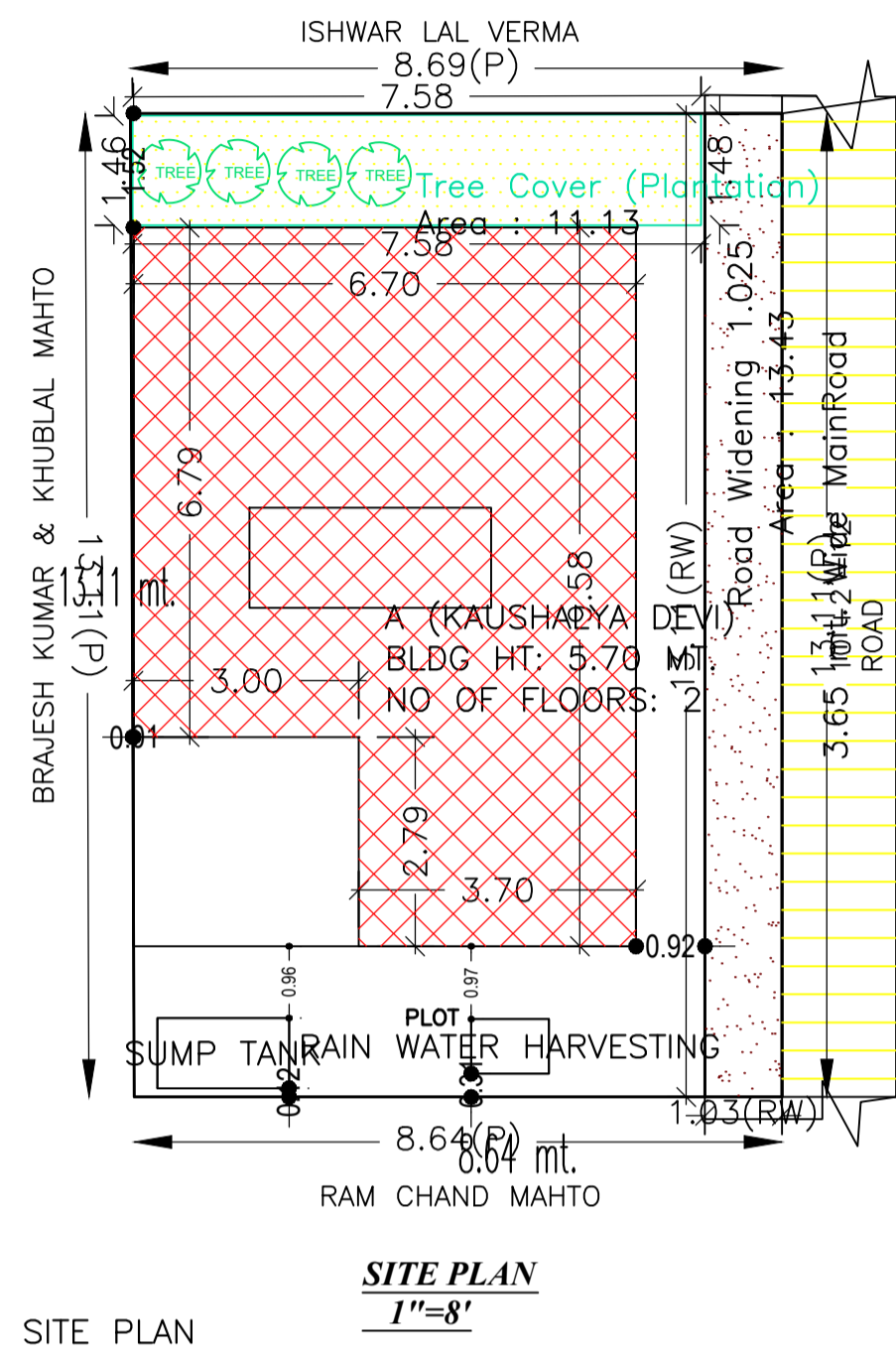

SITE PLAN  
1"=8"

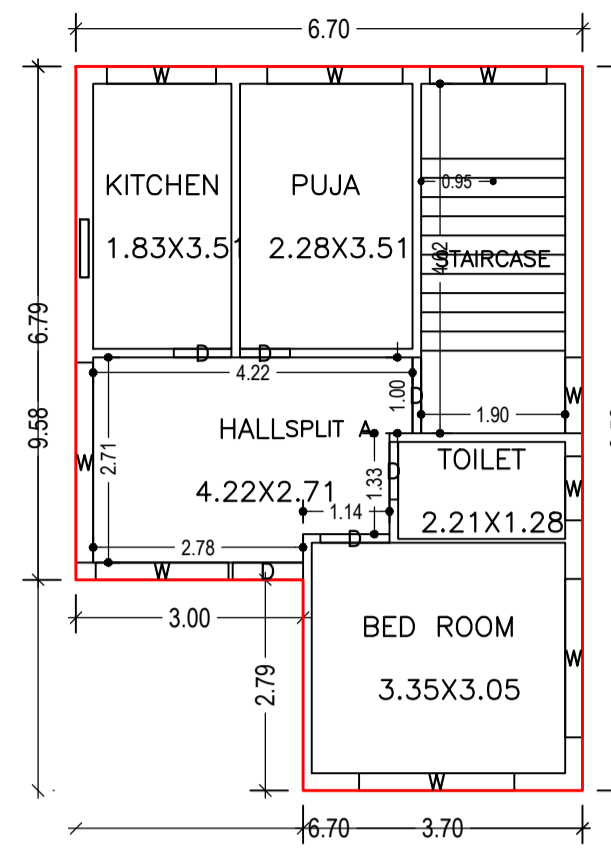
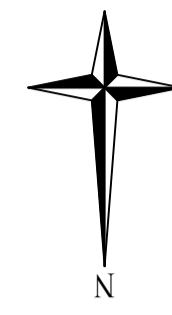

GROUND FLOOR PLAN  
(Proposed)  
(SCALE 1:100)

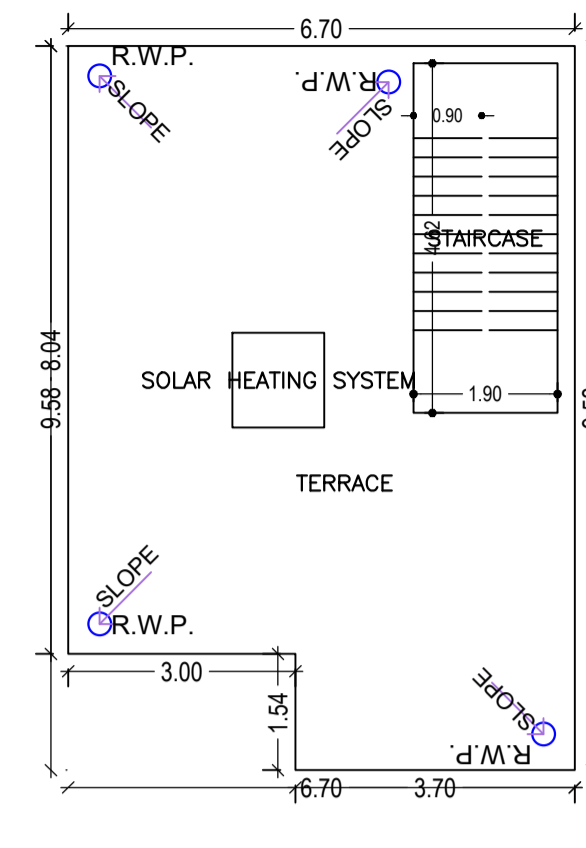

TERRACE FLOOR PLAN  
(SCALE 1:100)

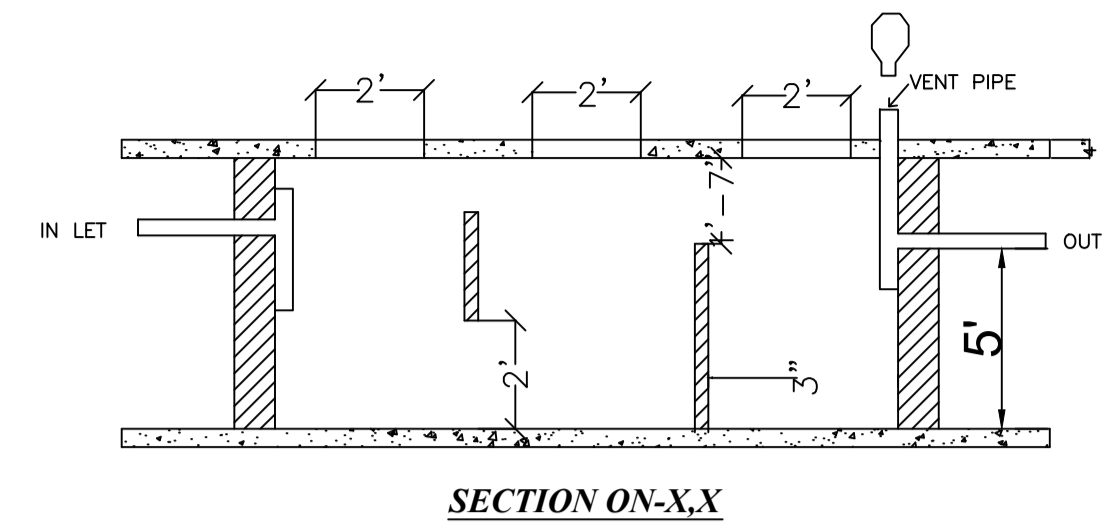

SECTION ON-X-X

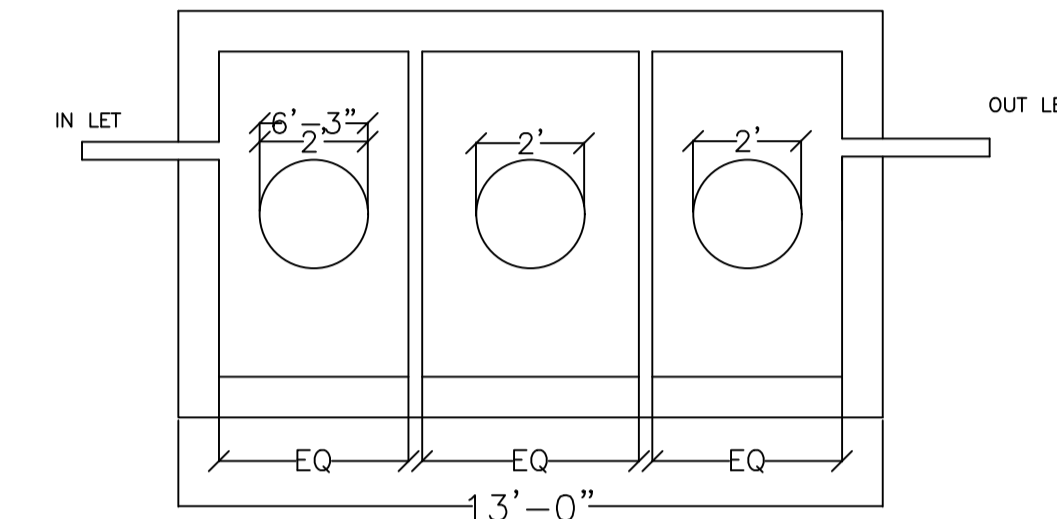

SEPTIC TANK

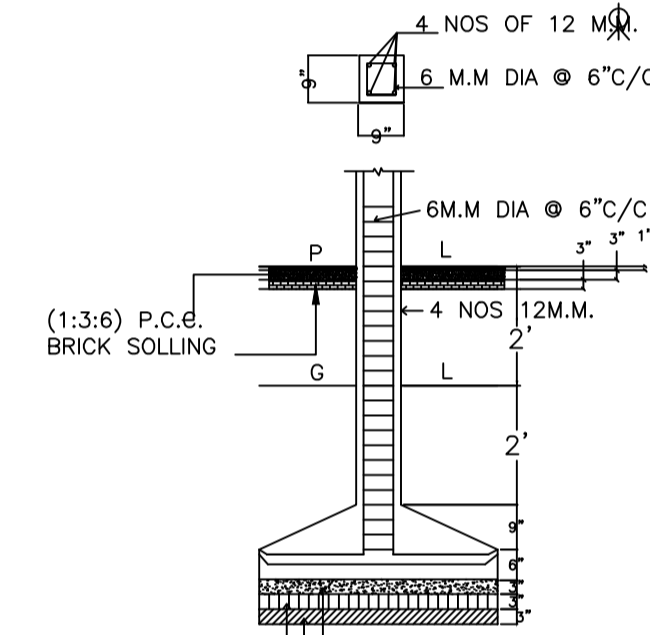

DETAILS OF COLUMN FOOTING

Proposal Basic Information	
Proposal File No.	MADA/BP/0291/2023
Owner Name	SMT. KAUSHALYA DEVI
Khata No	209
Plot No	671
Village Name	Topchanchi
Use	Residential
SubUse	Bungalow/ Dwelling / Non Apartment

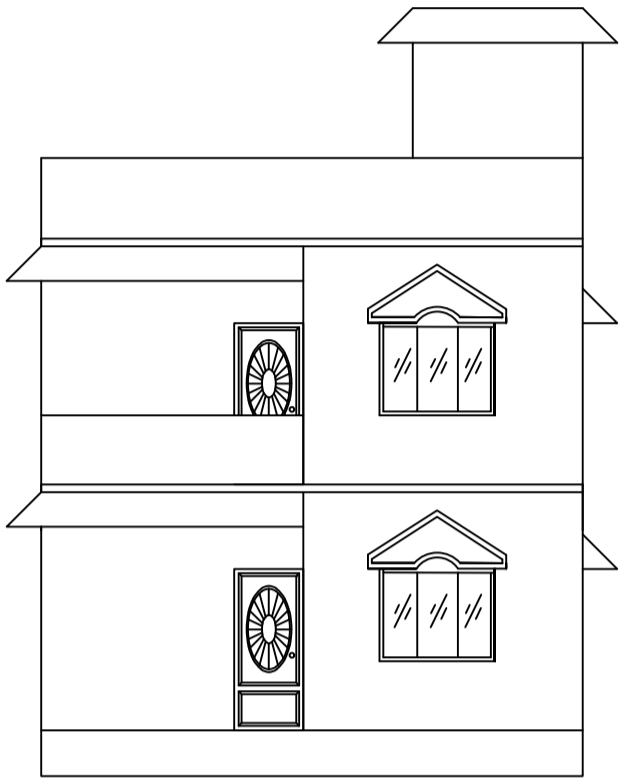

FRONT ELEVATION

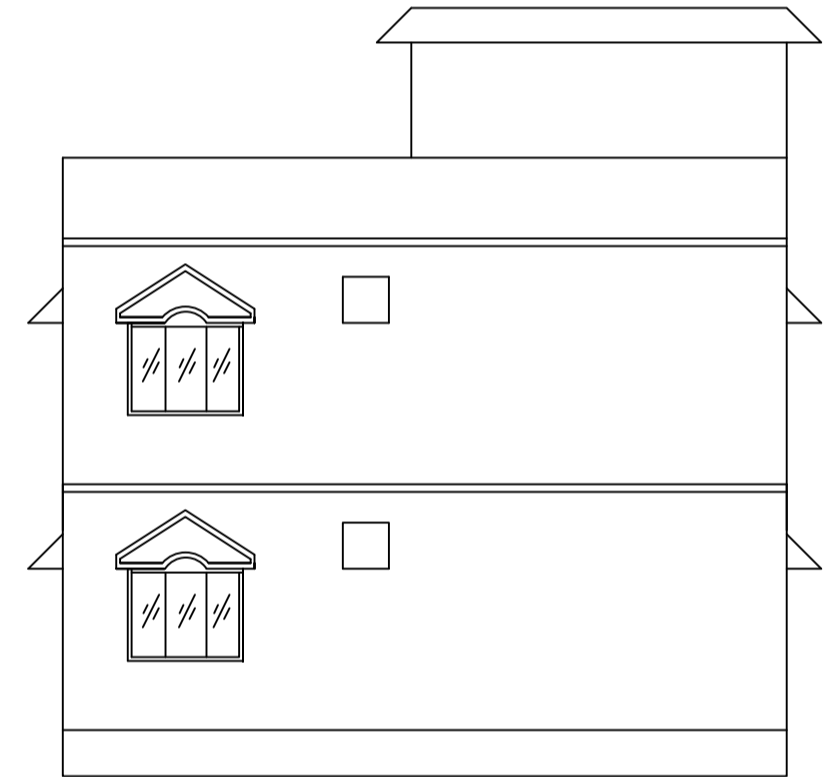

RIGHT SIDE ELEVATION

FAR & Tenement Details (Table 4c-1)

Building	No. of Same Bldg	Total Built Up Area (Sq.mt.)	Proposed FAR Area (Sq.mt.) Resi.	Total FAR Area (Sq.mt.)	Total Consumed Additional FAR Area (Sq.mt.)	Tnmt (No.)
A (KAUSHALYA DEVI)	1	111.56	111.56	111.56	111.56	01
Grand Total:	1	111.56	111.56	111.56	111.56	01

Floor Name	Floor FAR Details			Total	
	Proposed Built Up Area (Sq.mt.)	Proposed FAR Area (Sq.mt.)	Total Proposed Built Up Area (Sq.mt.)	Total FAR Area (Sq.mt.)	Total Consumed Additional FAR Area (Sq.mt.)
Ground Floor	55.78	55.78	55.78	55.78	55.78
First Floor	55.78	55.78	55.78	55.78	55.78
Terrace Floor	0.00	0.00	0.00	0.00	0.00
Total:	111.56	111.56	111.56	111.56	111.56

Building USE/SUBUSE Details

Building Name	Building Use	Building SubUse	Building Structure
A (KAUSHALYA DEVI)	Residential	Bungalow/ Dwelling / Non Apartment	Non-Highrise

SCHEDULE OF DOOR:

BUILDING NAME	NAME	LENGTH	HEIGHT	NOS
A (KAUSHALYA DEVI)	D	0.66	2.10	02
A (KAUSHALYA DEVI)	D	0.76	2.10	04
A (KAUSHALYA DEVI)	D	0.91	2.10	02
A (KAUSHALYA DEVI)	D	0.93	2.10	02
A (KAUSHALYA DEVI)	D	1.00	2.10	02

SCHEDULE OF WINDOW/VENTILATION:

BUILDING NAME	NAME	LENGTH	HEIGHT	NOS
A (KAUSHALYA DEVI)	W	0.85	1.20	02
A (KAUSHALYA DEVI)	W	1.00	1.20	02
A (KAUSHALYA DEVI)	W	1.44	1.20	02
A (KAUSHALYA DEVI)	W	1.55	1.20	02
A (KAUSHALYA DEVI)	W	1.76	1.20	02
A (KAUSHALYA DEVI)	W	1.79	1.20	02
A (KAUSHALYA DEVI)	W	2.05	1.20	02
A (KAUSHALYA DEVI)	W	2.10	1.20	02
A (KAUSHALYA DEVI)	W	2.65	1.20	02

Building :A (KAUSHALYA DEVI)

Floor Name	Total Built Up Area (Sq.mt.)	Proposed FAR Area (Sq.mt.) Resi.	Total FAR Area (Sq.mt.)	Total Consumed Additional FAR Area (Sq.mt.)	Tnmt (No.)
Ground Floor	55.78	55.78	55.78	55.78	01
First Floor	55.78	55.78	55.78	55.78	00
Terrace Floor	0.00	0.00	0.00	0.00	00
Total:	111.56	111.56	111.56	111.56	01
Total Number of Same Buildings	1				
Total:	111.56	111.56	111.56	111.56	01

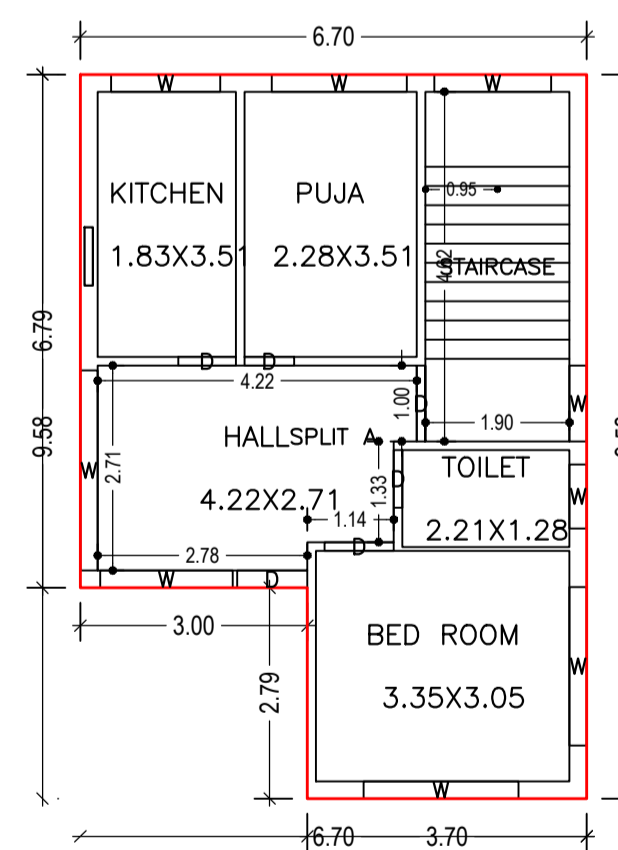

FIRST FLOOR PLAN  
(Proposed)  
(SCALE 1:100)

UnitBUA Table for Building :A (KAUSHALYA DEVI)

FLOOR	Name	UnitBUA Type	UnitBUA Area	Carpet Area	No. of Rooms	No. of Tenement
GROUND FLOOR PLAN	SPLIT A	FLAT	111.57	111.40	5	1
FIRST FLOOR PLAN	SPLIT A	FLAT	0.00	0.00	5	0
Total:	-	-	111.57	111.40	10	1

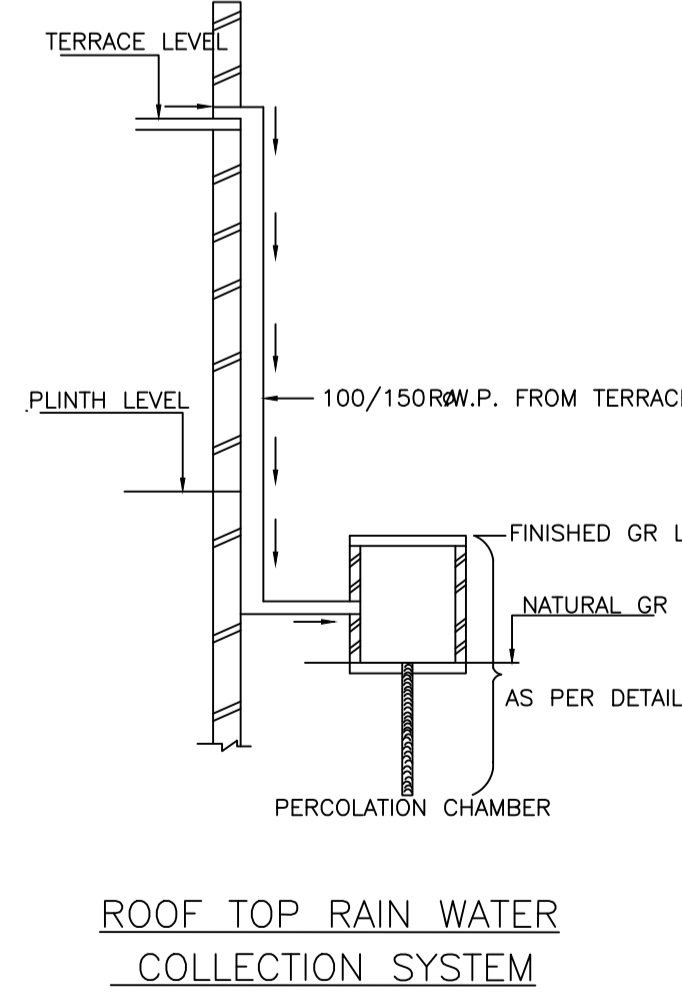

ROOF TOP RAIN WATER  
COLLECTION SYSTEM

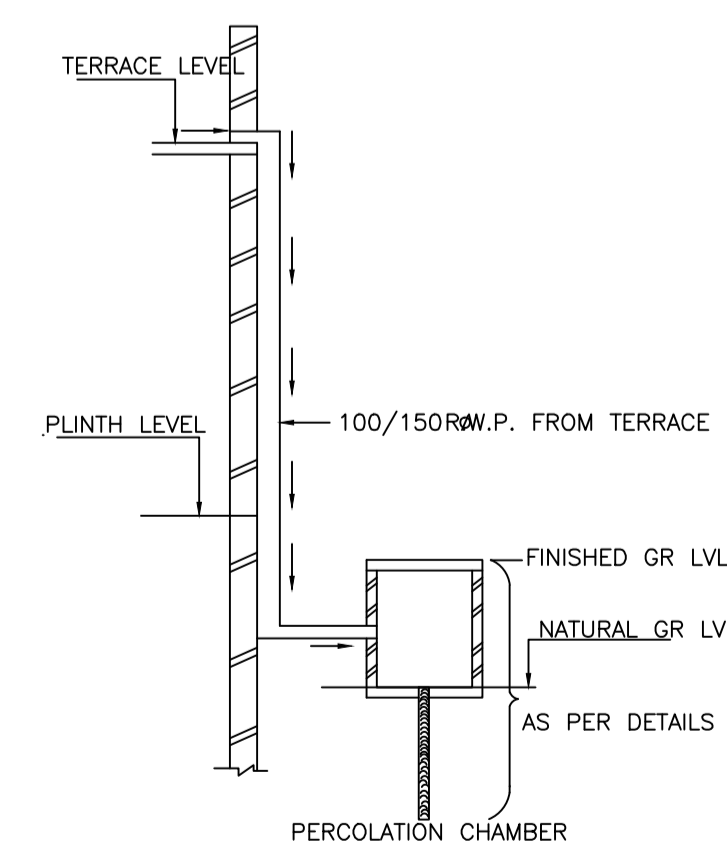

ROOF TOP RAIN WATER  
COLLECTION SYSTEM

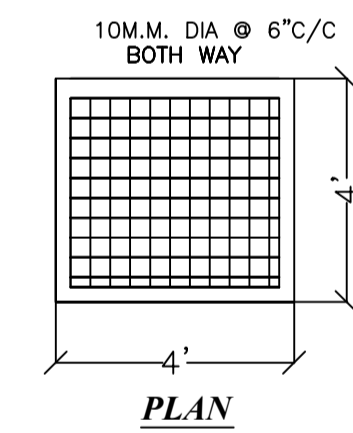

PLAN

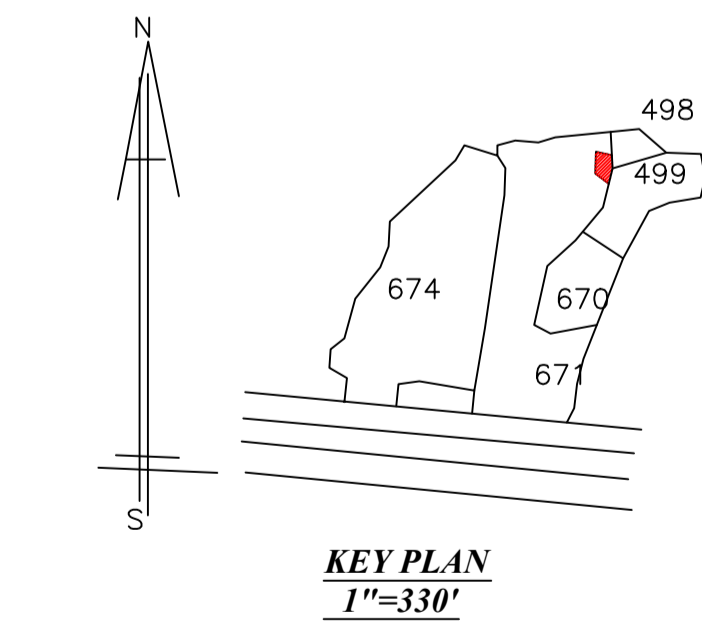

KEY PLAN  
1"=330'

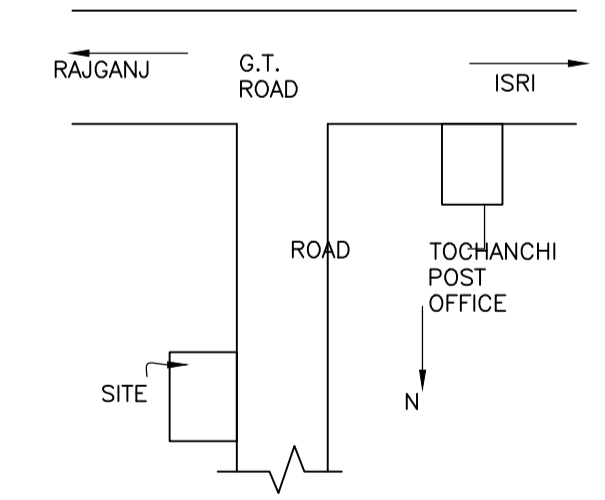

LOCATION PLAN

LTP NAME AND SIGNATURE	STRUCTURAL ENG'S NAME AND SIGNATURE	BUILDER NAME AND SIGNATURE	DIGITAL SIGNATURE
SANTOSH MADA/ENG/0022/2019			