

Proposal Basic Information

Proposal File No.	MADA/BP/0325/2023
Owner Name	SRI ANISH SHAH
Khata No.	09 (OLD), 220 (NEW)
Plot No.	591 (OLD), 521 (NEW)
Village Name	Amaghata
Use	Residential
SubUse	Bungalow Dwelling / Non Apartment

AREA STATEMENT MINERAL AREA DEVELOPMENT AUTHORITY	VERSION NO. 1.0.66
PROJECT DETAIL	VERSION DATE: 16/10/2020
Region: JHARKHAND URBAN LOCAL BODIES	Plot Use: Residential
District: DHANBAD	Plot SubUse: Bungalow Dwelling / Non Apartment
Authority: MINERAL AREA DEVELOPMENT AUTHORITY	Plot Neary/Religious/Structure: NA
Project No: MADA/BP/0325/2023	North: Plot No. - BOUNDARY WALL
Application Type: General Proposal	South: Road Width - 11.14
Nature of Development: New	East: Plot No. - LOT NO-76
Location of Development Area: Old Area	West: Plot No. - LOT NO-76
AREA DETAILS:	SQ.MT.
AREA OF PLOT (Minimum)	116.13
NET AREA OF PLOT (Gross Plot Area - Deduction from Gross Plot Area)	116.13
Deduction for Balance Plot Area/From Gross Plot Area:	
Common Plot	10.71
Total	10.71
BALANCE AREA OF PLOT (Net Plot Area - Recreational/Amenity space)	105.42
FLOOR AREA FOR COVERAGE (Net Plot Area)	116.13
Plot Area for FAR (Net Plot Area + Road Widening Area)	116.13
COVERAGE CHECK	
Permissible Coverage area (70.00 %)	81.29
Proposed Coverage Area (60.03 %)	69.71
Total Prop. Coverage Area (60.03 %)	69.71
Balance coverage area (9.97 %)	11.58
FAR CHECK	
Perm. FAR Area (2.500)	290.32
Total Perm. FAR area	290.32
Residential FAR	141.12
Proposed FAR Area	141.12
Total Proposed FAR Area	141.12
Consumed FAR (Factor)	1.22
Balance FAR Area	149.20
BUILT UP AREA CHECK	
Total Proposed Built Up Area	141.12
ARCHITECT (Regd)	ANIL KUMAR CHAUDHARY
ENGINEER (Regd)	
SUPERVISOR (Regd)	
OWNER (Regd)	SRI ANISH SHAH
DEVELOPMENT AUTHORITY	LOCAL BODY

COLOR INDEX	
PILOT BOUNDARY	Black
ABUTTING ROAD	Green
PROPOSED CONSTRUCTION	Red
COMMON PLOT	Yellow
ROAD WIDENING AREA	Blue
EXISTING (To be retained)	Orange
EXISTING (To be demolished)	Grey

BUILDINGWISE FLOOR FAR DETAILS				
Floor Name	Building Name	Total Proposed Built Up Area (Sq.mt.)	Total Proposed FAR Area (Sq.mt.)	Total FAR Area (Sq.mt.)
Ground Floor	RESI (ANISH)	69.71	69.71	69.71
First Floor	RESI (ANISH)	71.41	71.41	71.41
Terrace Floor	RESI (ANISH)	0.00	0.00	0.00
Total	RESI (ANISH)	141.12	141.12	141.12

BUILDING USE/SUBUSE DETAILS			
Building Name	Building Use	Building SubUse	Building Structure
RESI (ANISH)	Residential	Bungalow Dwelling / Non Apartment	Non-Highrise

FAR & Tenement Details (Table 4c-1)								
Building	No. of Same Bldg	Gross Built Up Area (Sq.mt.)	Deductions From Gross BUA (Area in Sq.mt.)	Total Built Up Area (Sq.mt.)	Proposed FAR Area (Sq.mt.)	Total FAR Area (Sq.mt.)	Total Consumed Additional FAR Area (Sq.mt.)	Tntmt (No.)
RESI (ANISH)	1	142.36	1.24	141.12	141.12	141.12	141.12	01
Grand Total	1	142.36	1.24	141.12	141.12	141.12	141.12	01

BUILDING :RESI (ANISH)							
Floor Name	Gross Built Up Area	Deductions From Gross BUA (Area in Sq.mt.)	Total Built Up Area (Sq.mt.)	Proposed FAR Area (Sq.mt.)	Total FAR Area (Sq.mt.)	Total Consumed Additional FAR Area (Sq.mt.)	Tntmt (No.)
Ground Floor	69.71	0.00	69.71	69.71	69.71	69.71	01
First Floor	72.65	1.24	71.41	71.41	71.41	71.41	00
Terrace Floor	0.00	0.00	0.00	0.00	0.00	0.00	00
Total	142.36	1.24	141.12	141.12	141.12	141.12	01
Total Number of Same Buildings	1						
Total	142.36	1.24	141.12	141.12	141.12	141.12	01

SCHEDULE OF DOOR:				
BUILDING NAME	NAME	LENGTH	HEIGHT	NOS
RESI (ANISH)	D	0.84	2.10	05
RESI (ANISH)	D	0.91	2.10	01
RESI (ANISH)	D	0.92	2.10	00
RESI (ANISH)	D	0.99	2.10	00
RESI (ANISH)	D	1.07	2.10	01

SCHEDULE OF WINDOW/VENTILATION:				
BUILDING NAME	NAME	LENGTH	HEIGHT	NOS
RESI (ANISH)	W	0.61	1.20	04
RESI (ANISH)	W	1.07	1.20	01
RESI (ANISH)	W	1.53	1.20	00
RESI (ANISH)	W	1.61	1.20	01
RESI (ANISH)	W	2.14	1.20	01

UnitBUA Table for Building :RESI (ANISH)						
FLOOR	Name	UnitBUA Type	UnitBUA Area	Carpet Area	No. of Rooms	No. of Tenement
GROUND FLOOR PLAN	SPLIT 1	FLAT	141.12	139.02	6	1
			0.00	0.00	7	0
FIRST FLOOR PLAN	SPLIT 1	FLAT	141.12	139.02	13	1
Total	-	-	141.12	139.02	17	1

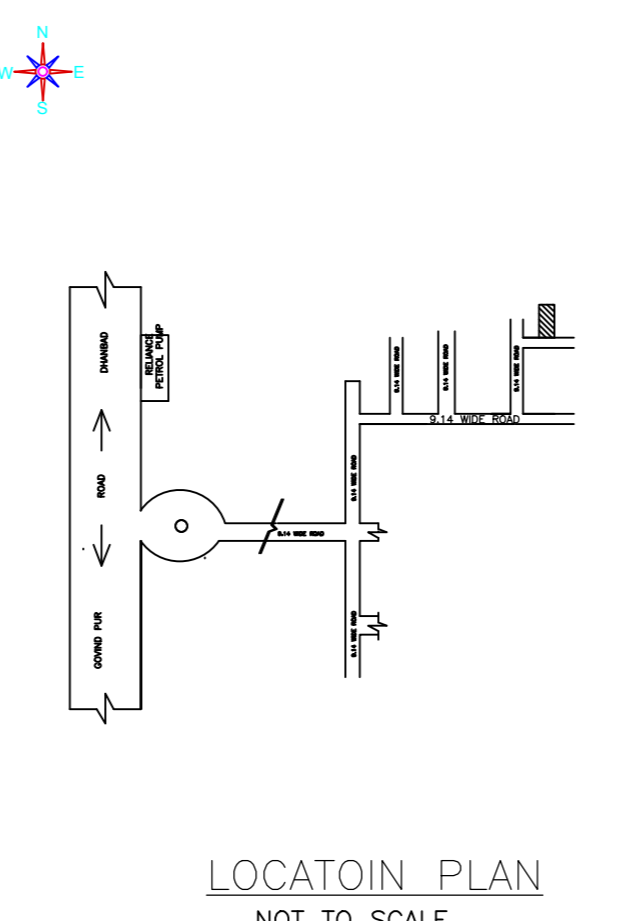
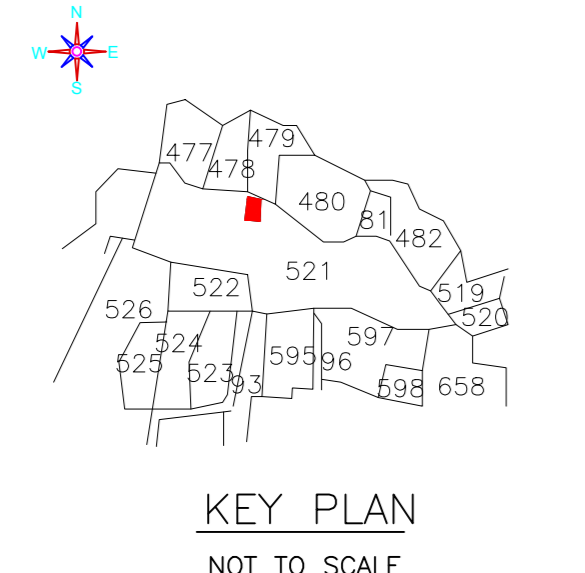
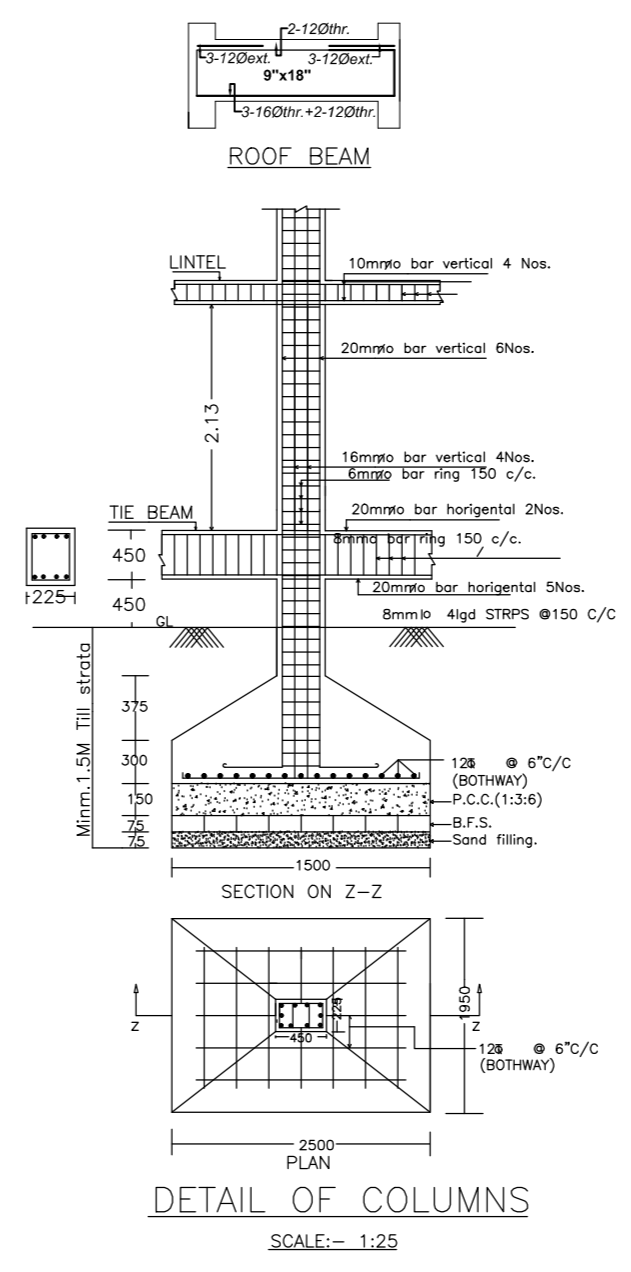
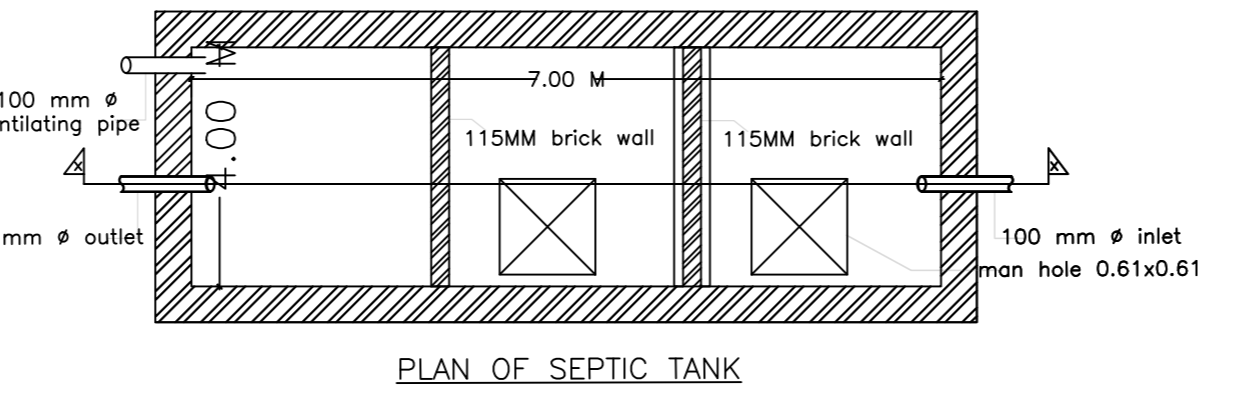
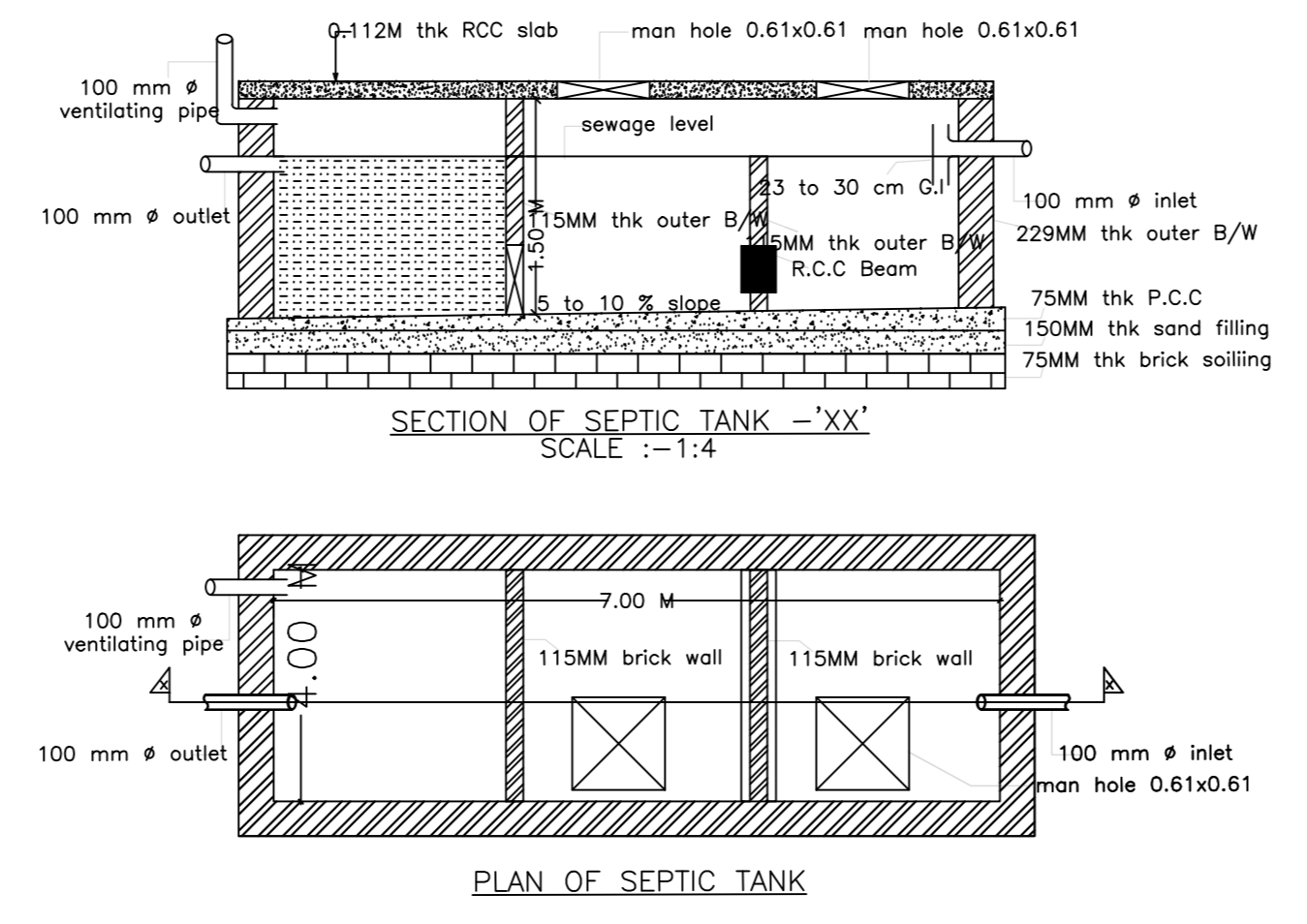
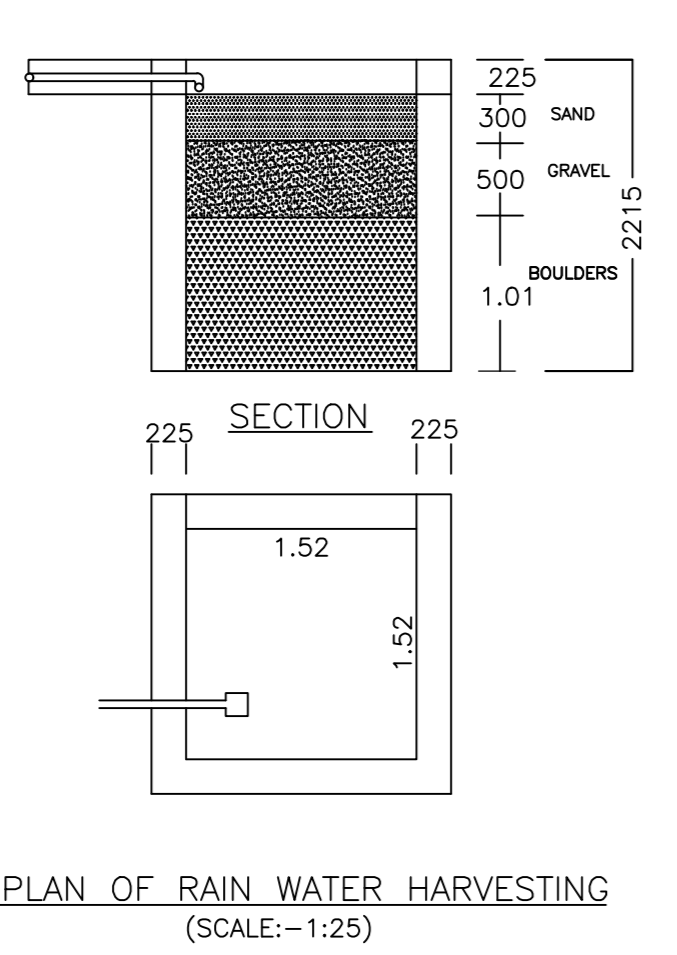
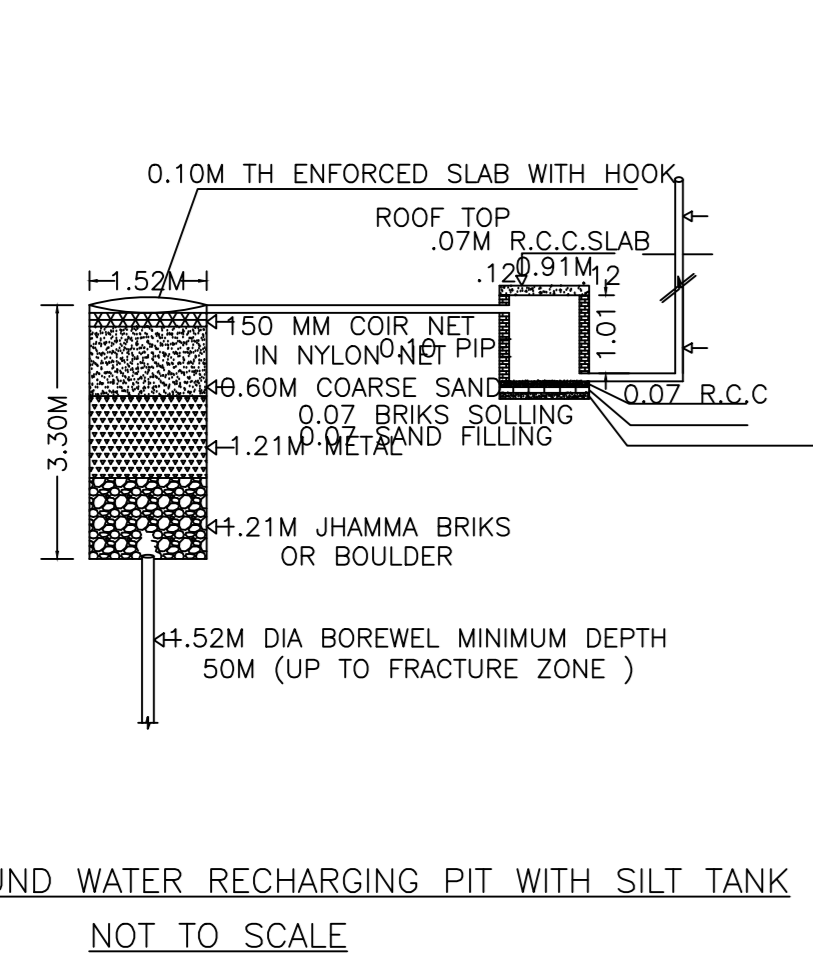
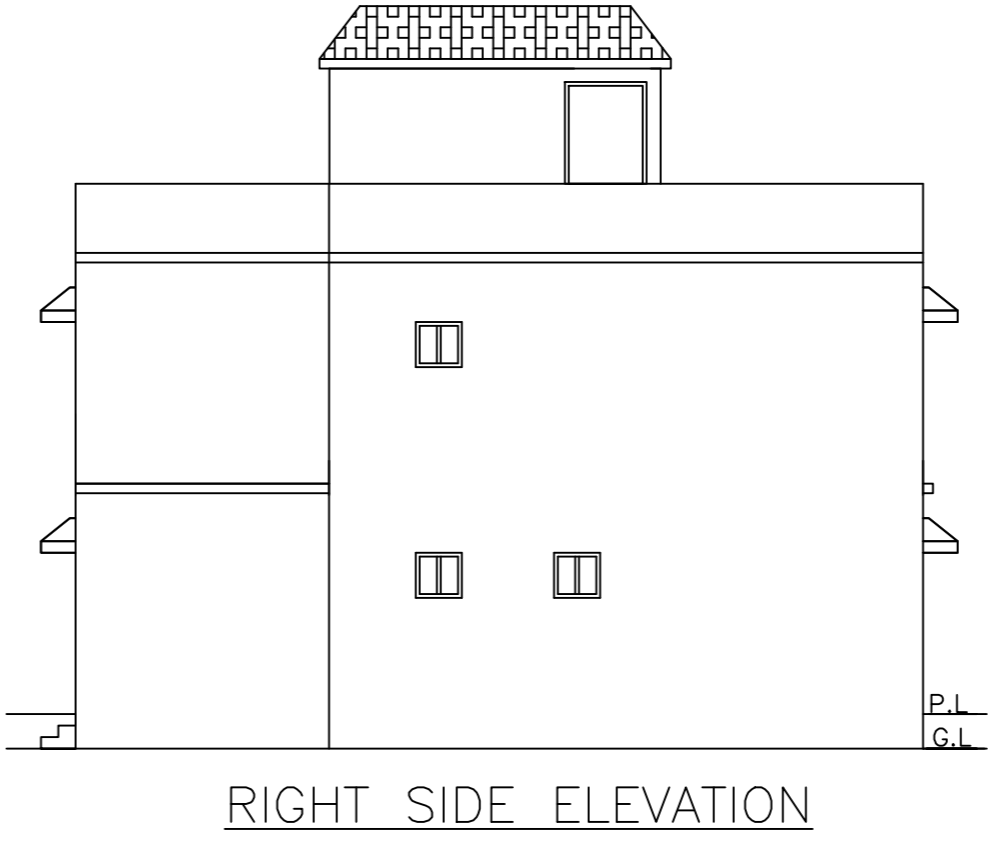
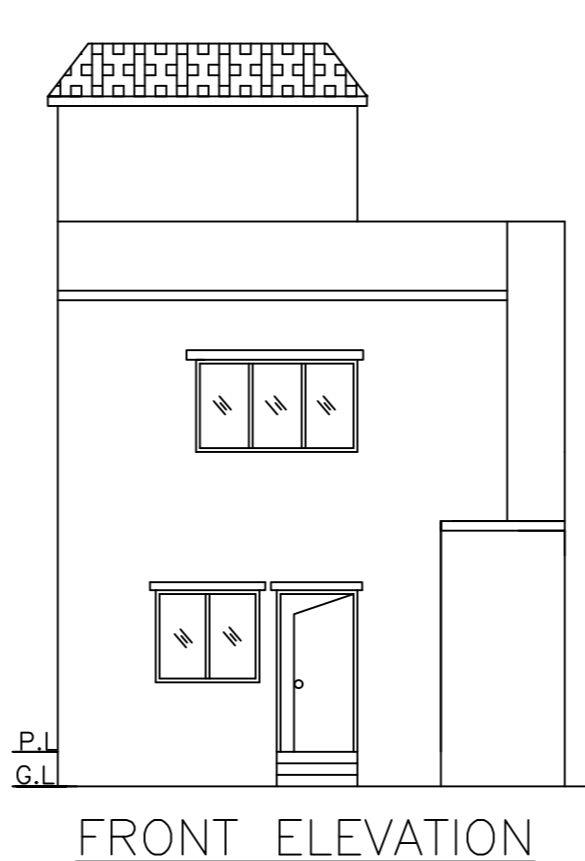
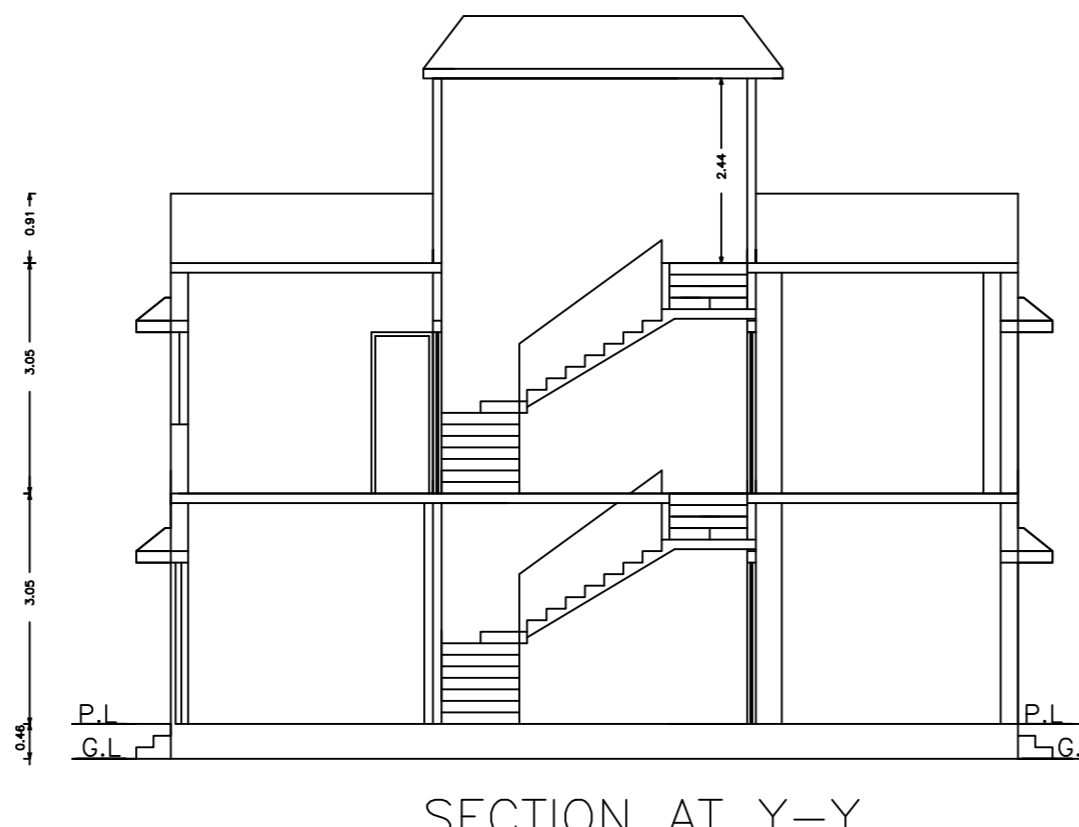
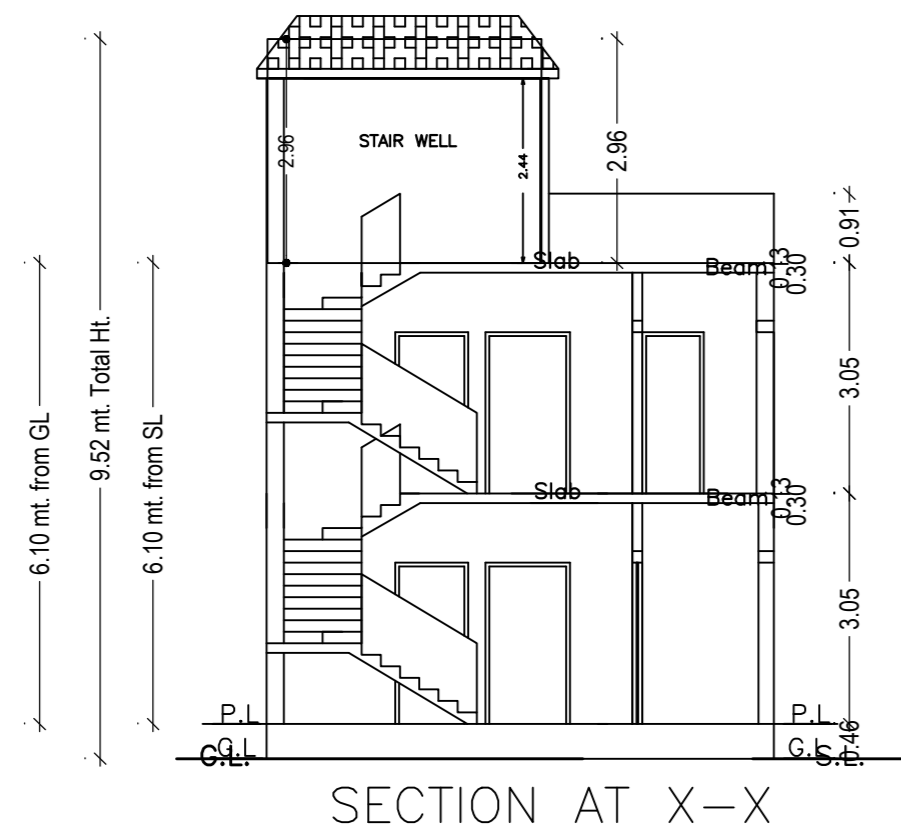
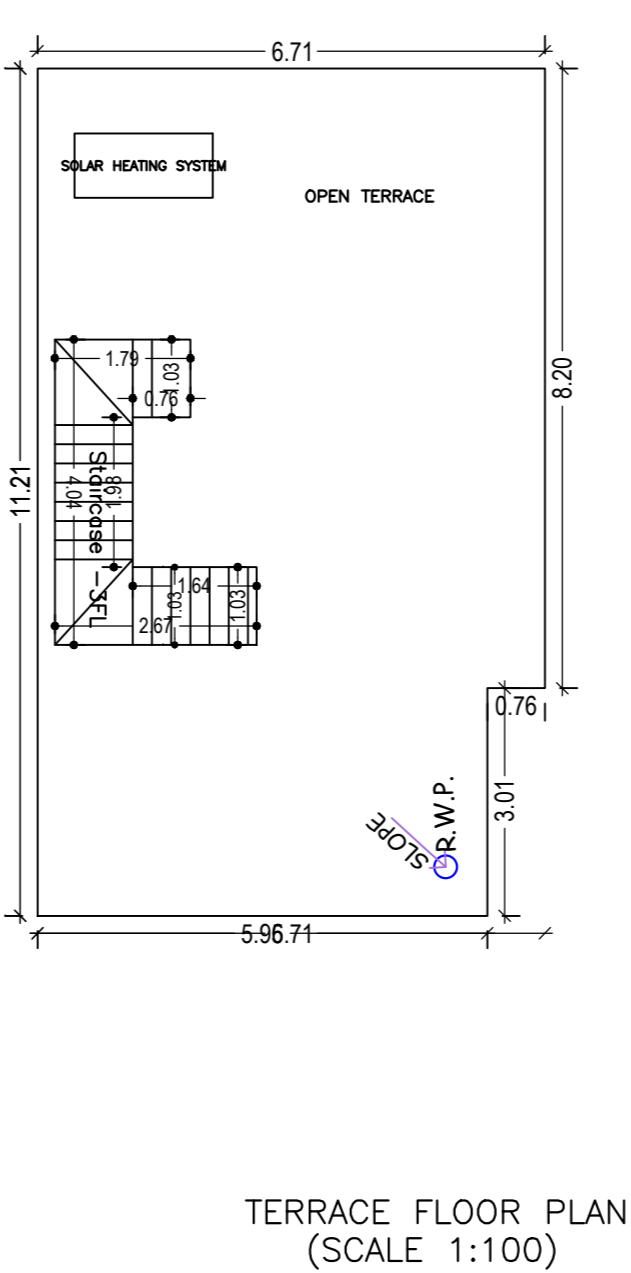
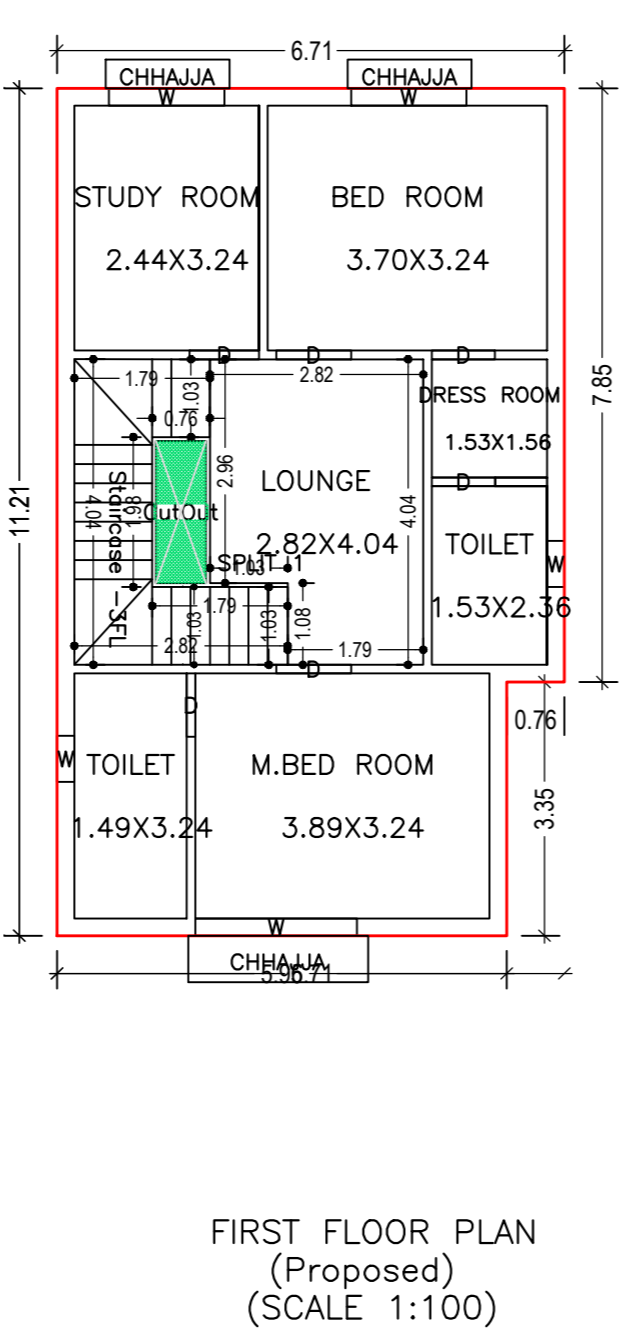
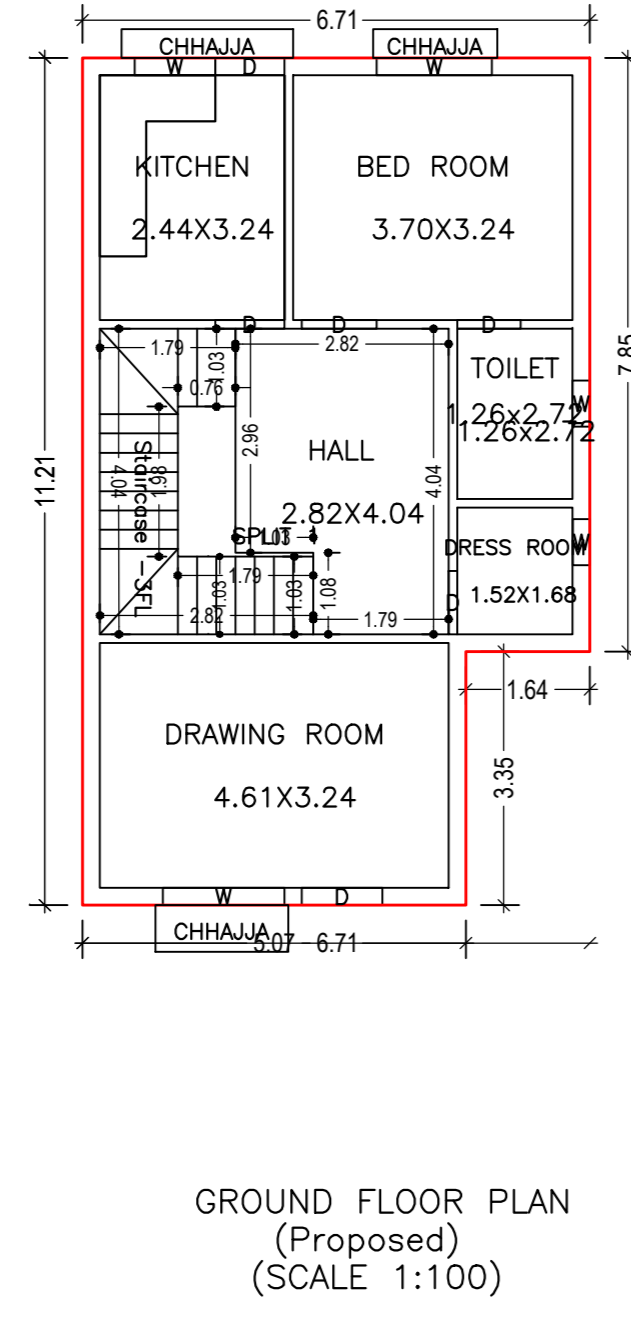
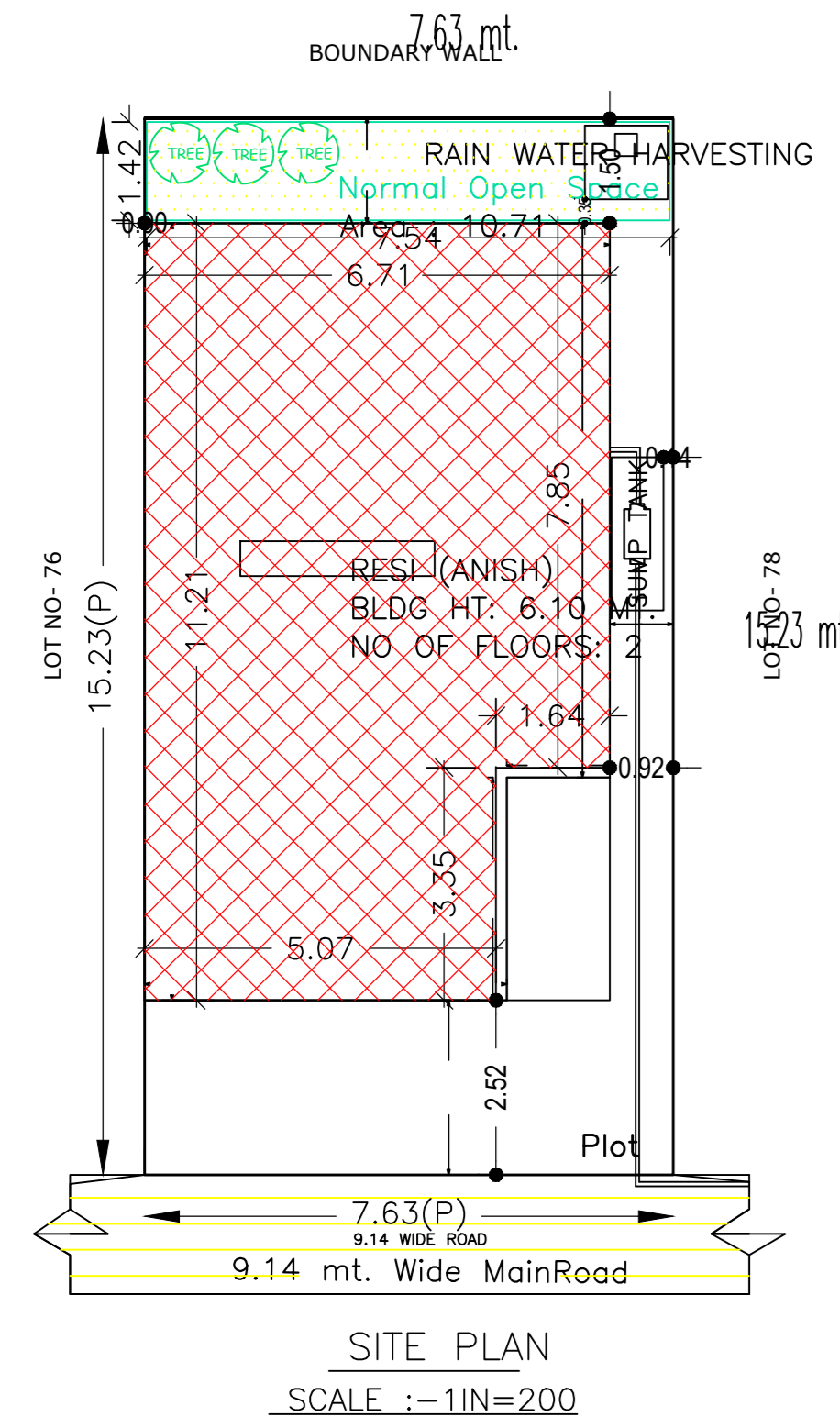

LTP NAME AND SIGNATURE: ANIL KUMAR CHAUDHARY
STRUCTURAL ENG'S NAME AND SIGNATURE: MADA/ENG/005/2019
BUILDER NAME AND SIGNATURE:
DIGITAL SIGNATURE: