

Proposal Basic Information

Proposal File No.	MADA/BP/0305/2023
Owner Name	AMIT KUMAR SINGH
Khata No	OLD: 33, NEW: 280
Plot No	Old: 2822, New: 1075
Village Name	Sijua
Use	Residential
SubUse	Bungalow/ Dwelling / Non Apartment

AREA STATEMENT MINERAL AREA DEVELOPMENT AUTHORITY

VERSION NO. : 1.0.66
VERSION DATE: 16/10/2020

Region: JHARKHAND URBAN LOCAL BODIES	Plot Use: Residential
District: DHANBAD	Plot SubUse: Bungalow/ Dwelling / Non Apartment
Authority: MINERAL AREA DEVELOPMENT AUTHORITY	PlotNearbyReligiousStructure: NA
Inward No: MADA/BP/0305/2023	PlotSubPlot No: Old: 2822, New: 1075
Application Type: General Proposal	North: Plot No. - PUSHPA SINGH
Project Type: Building Permission	South: Plot No. - SUJIT KUMAR
Nature of Development: Addition or Alteration	East: Road Width - 6.1
Location of Development Area: Old Area	West: Plot No. - SELLERS NIJ

AREA OF PLOT (Minimum)	(A)	SQ.MT.	99.87
NET AREA OF PLOT(Gross Plot Area - Deduction from Gross Plot area)	(A-Deductions)		99.87
Deduction for Balance Plot Area(from Gross Plot Area)			
Common Plot			15.14
Total			15.14
BALANCE AREA OF PLOT(Net Plot Area - Recreational/Amenity space)	(A-Deductions)		84.73
PLOT AREA FOR COVERAGE(Net Plot Area)	(A-Deductions)		99.87
Plot Area for FAR (Net Plot Area + Road Widening Area)	(A-Deductions)		99.87

COVERAGE CHECK		
Permissible Coverage area (70.00 %)		69.91
Proposed Coverage Area (50.22 %)		50.15
Total Prop. Coverage Area (50.22 %)		50.15
Balance coverage area (19.79 %)		19.76

FAR CHECK		
Perm. FAR Area (2.500)		249.68
Total Perm. FAR area		249.68
Residential FAR		99.02
Proposed FAR Area		99.02
Total Proposed FAR Area		99.02
Consumed FAR (Factor)		0.99
Balance FAR Area		150.66

BUILT UP AREA CHECK		
Total Proposed BuiltUp Area		100.30

ARCHITECT (Regd)	MANISH AGARWAL	
ENGINEER (Regd)		
SUPERVISOR (Regd)		
OWNER (Regd)	AMIT KUMAR SINGH	
DEVELOPMENT AUTHORITY		LOCAL BODY

UnitBUA Table for Building :A (AMIT KUMAR SINGH)

FLOOR	Name	UnitBUA Type	Entity Type	UnitBUA Area	Carpet Area	No. of Rooms	No. of Tenement
GROUND FLOOR PLAN	SPLIT AMIT KUMAR SINGH	FLAT	Existing	69.36	68.75	5	1
FIRST FLOOR PLAN	SPLIT AMIT KUMAR SINGH	FLAT	Proposed	0.00	0.00	4	0
Total:	-	-	-	69.36	68.75	9	1

Building :A (AMIT KUMAR SINGH)

Floor Name	Total Built Up Area (Sq.mt.)	Existing Built Up Area (Sq.mt.)	Proposed Built Up Area (Sq.mt.)	Deductions (Area in Sq.mt.)	Existing FAR Area (Sq.mt.)	Proposed FAR Area (Sq.mt.)	Total FAR Area (Sq.mt.)	Total Consumed Additional FAR Area (Sq.mt.)	Trmt (No.)
Ground Floor	50.15	50.15	0.00	0.00	50.15	0.00	50.15	50.15	01
First Floor	50.15	0.00	50.15	1.28	0.00	48.87	48.87	48.87	00
Terrace Floor	0.00	0.00	0.00	0.00	0.00	0.00	0.00	0.00	00
Total :	100.30	50.15	50.15	1.28	50.15	48.87	99.02	99.02	01
Total Number of Same Buildings :	1								
Total :	100.30	50.15	50.15	1.28	50.15	48.87	99.02	99.02	01

SCHEDULE OF DOOR:

BUILDING NAME	NAME	LENGTH	HEIGHT	NOS
A (AMIT KUMAR SINGH)	D2	0.90	2.10	06
A (AMIT KUMAR SINGH)	D3	0.90	2.10	01
A (AMIT KUMAR SINGH)	D1	1.00	2.10	03

SCHEDULE OF WINDOW/VENTILATION:

BUILDING NAME	NAME	LENGTH	HEIGHT	NOS
A (AMIT KUMAR SINGH)	V	1.00	1.20	02
A (AMIT KUMAR SINGH)	W2	1.20	1.20	04
A (AMIT KUMAR SINGH)	W1	1.50	1.20	08

Balcony Calculations Table

FLOOR	SIZE	AREA	TOTAL AREA
FIRST FLOOR PLAN	1.20 X 2.14 X 1 X 1	2.57	2.57
Total	-	-	2.57

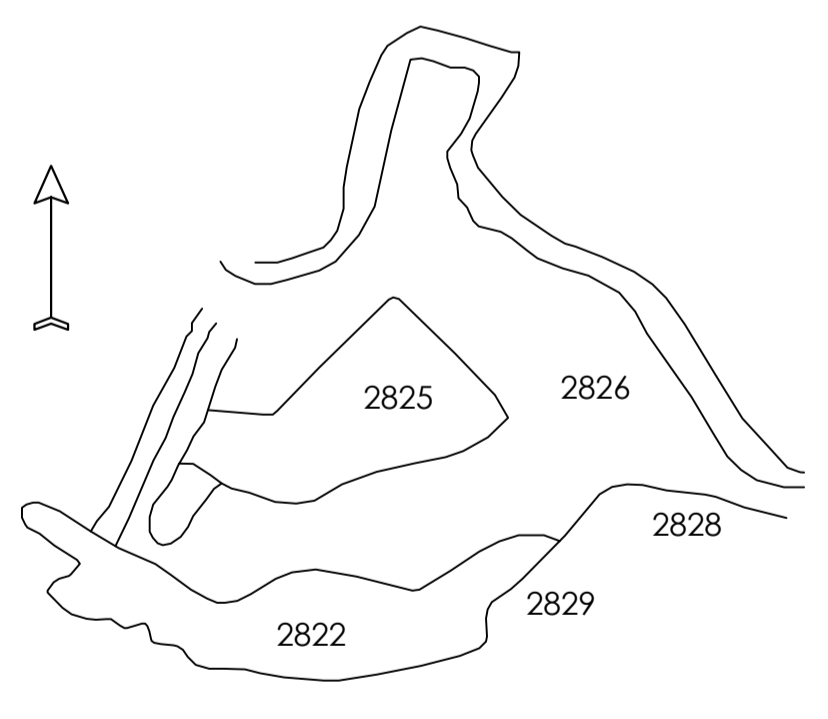

KEY MAP

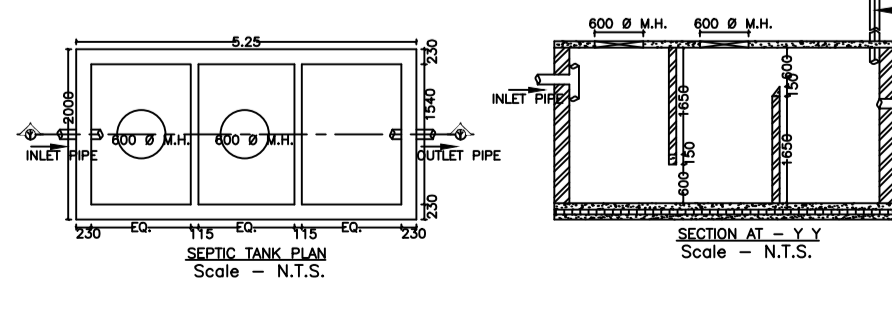
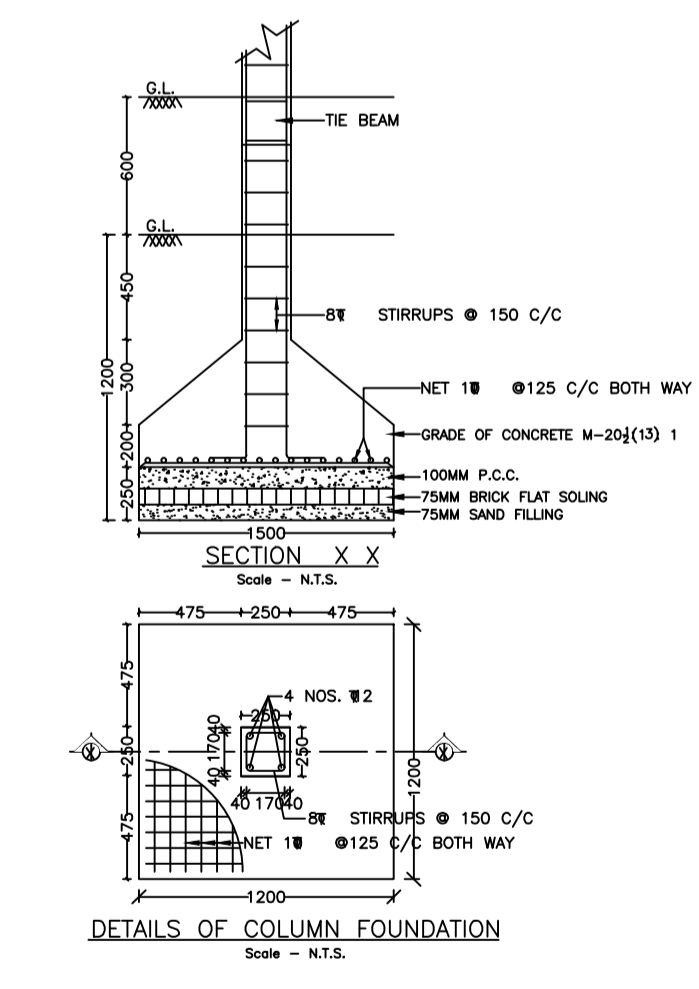
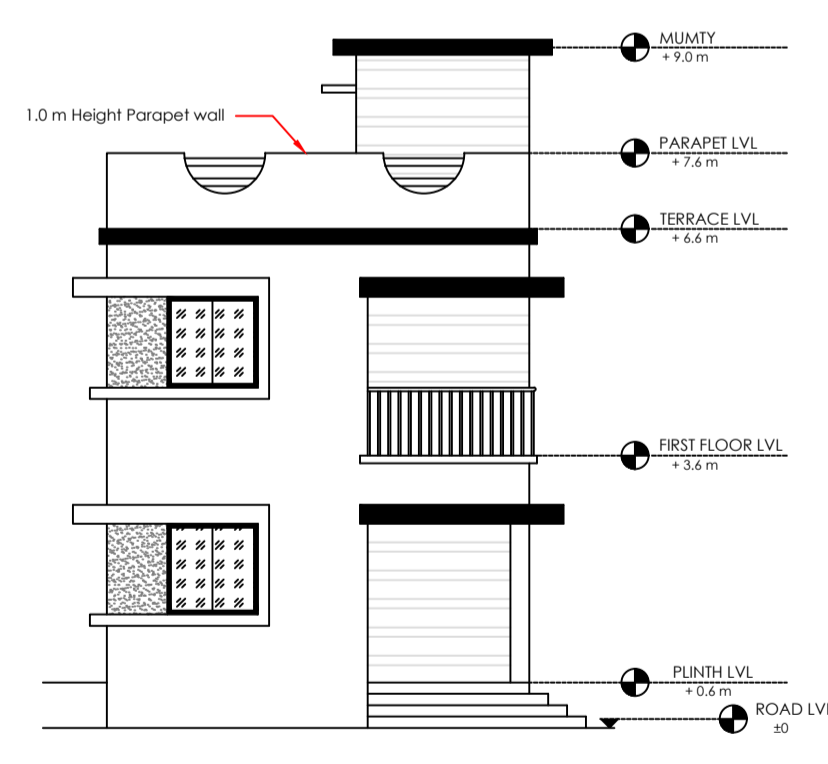
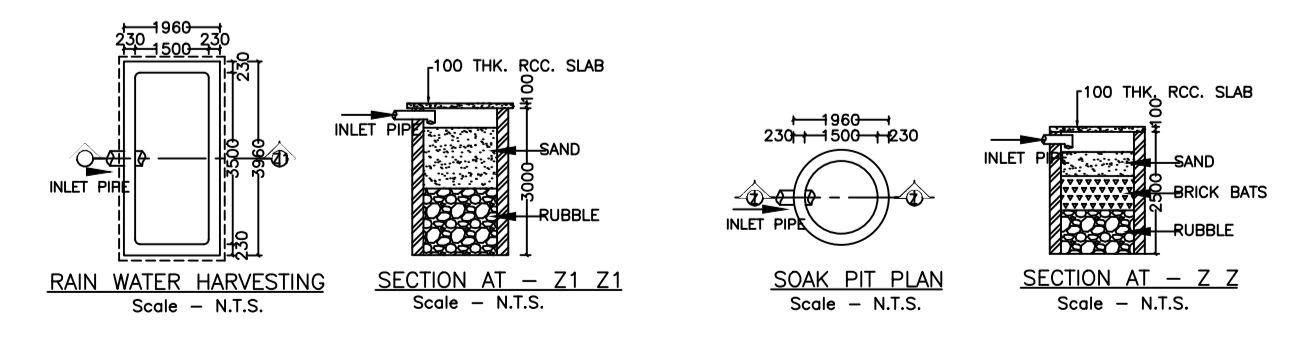

COLOR INDEX

PLOT BOUNDARY	Black
ABUTTING ROAD	Green
PROPOSED CONSTRUCTION	Red
COMMON PLOT	Yellow
ROAD WIDENING AREA	Orange
EXISTING (To be retained)	Blue
EXISTING (To be demolished)	Light Blue

Buildingwise Floor FAR Details

Floor Name	Building Name A (AMIT KUMAR SINGH)				Total			
	Proposed Built Up Area (Sq.mt.)	Existing Built Up Area (Sq.mt.)	Proposed FAR Area (Sq.mt.)	Existing FAR Area (Sq.mt.)	Total Proposed Built Up Area (Sq.mt.)	Total Existing Built Up Area (Sq.mt.)	Total FAR Area (Sq.mt.)	Total Existing FAR Area (Sq.mt.)
Ground Floor	0.00	50.15	0.00	50.15	0.00	50.15	0.00	50.15
First Floor	50.15	0.00	48.87	0.00	50.15	0.00	48.87	0.00
Terrace Floor	0.00	0.00	0.00	0.00	0.00	0.00	0.00	0.00
Total :	50.15	50.15	48.87	50.15	50.15	50.15	48.87	50.15

Building USE/SUBUSE Details

Building Name	Building Use	Building SubUse	Building Structure
A (AMIT KUMAR SINGH)	Residential	Bungalow/ Dwelling / Non Apartment	Non-Highrise

FAR & Tenement Details (Table 4c-1)

Building	No. of Same Bldg	Total Built Up Area (Sq.mt.)	Existing Built Up Area (Sq.mt.)	Proposed Built Up Area (Sq.mt.)	Deductions (Area in Sq.mt.)	Existing FAR Area (Sq.mt.)	Proposed FAR Area (Sq.mt.)	Total FAR Area (Sq.mt.)	Total Consumed Additional FAR Area (Sq.mt.)	Trmt (No.)
A (AMIT KUMAR SINGH)	1	100.30	50.15	50.15	1.28	50.15	48.87	99.02	99.02	01
Grand Total	1	100.30	50.15	50.15	1.28	50.15	48.87	99.02	99.02	01

LTP NAME AND SIGNATURE	STRUCTURAL ENG'S NAME AND SIGNATURE	BUILDER NAME AND SIGNATURE	DIGITAL SIGNATURE
MANISH AGARWAL MADA/ARC/0008/2020			