

Project Title - RAJIV RANJAN

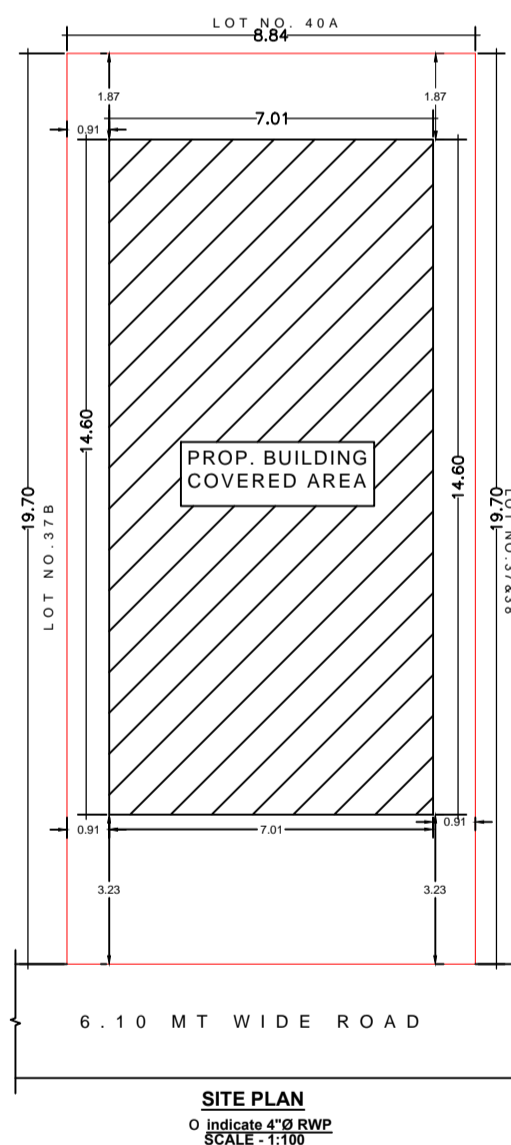
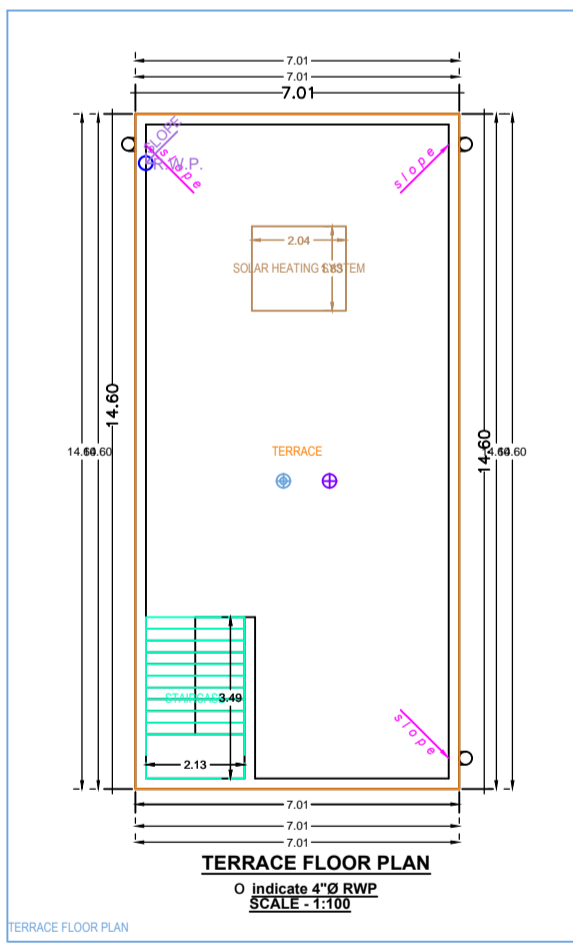
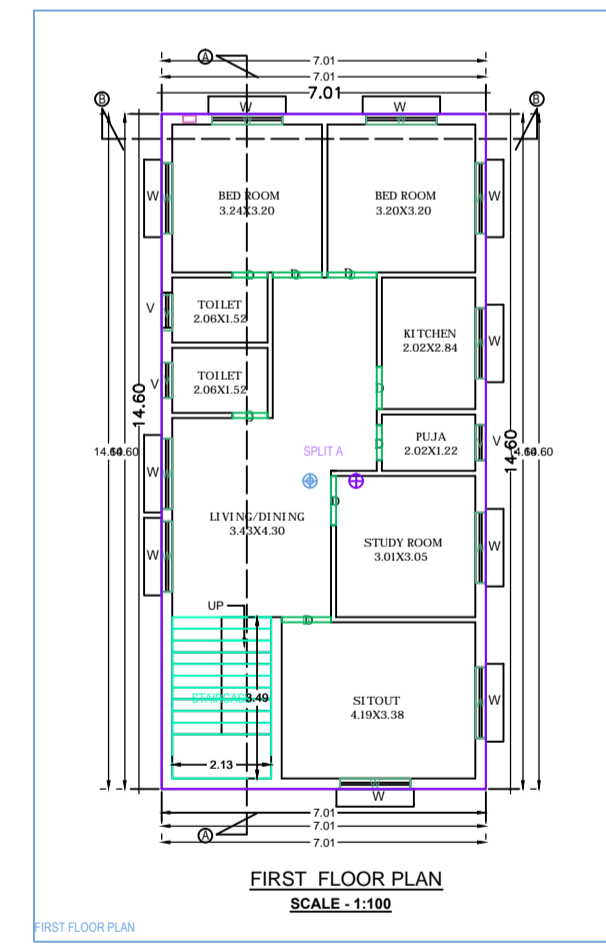
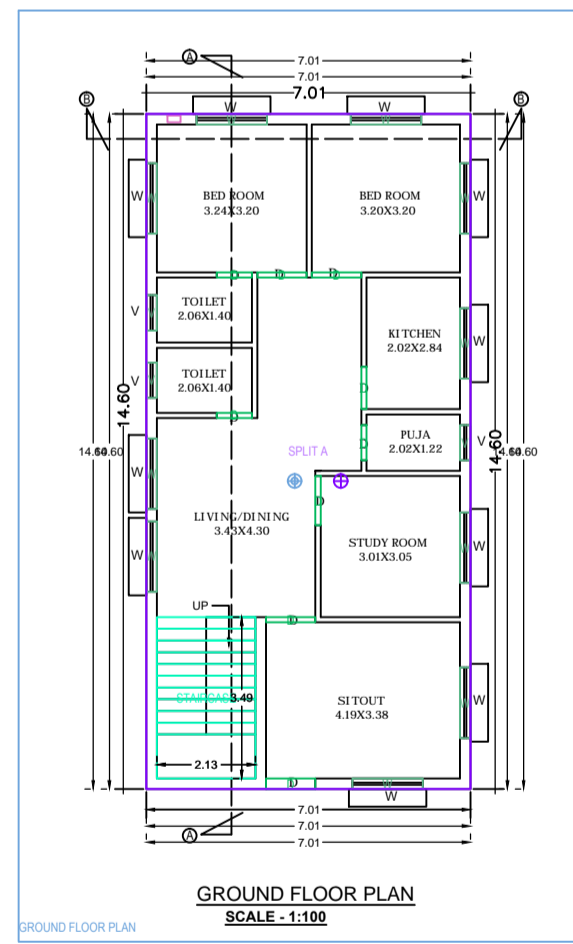
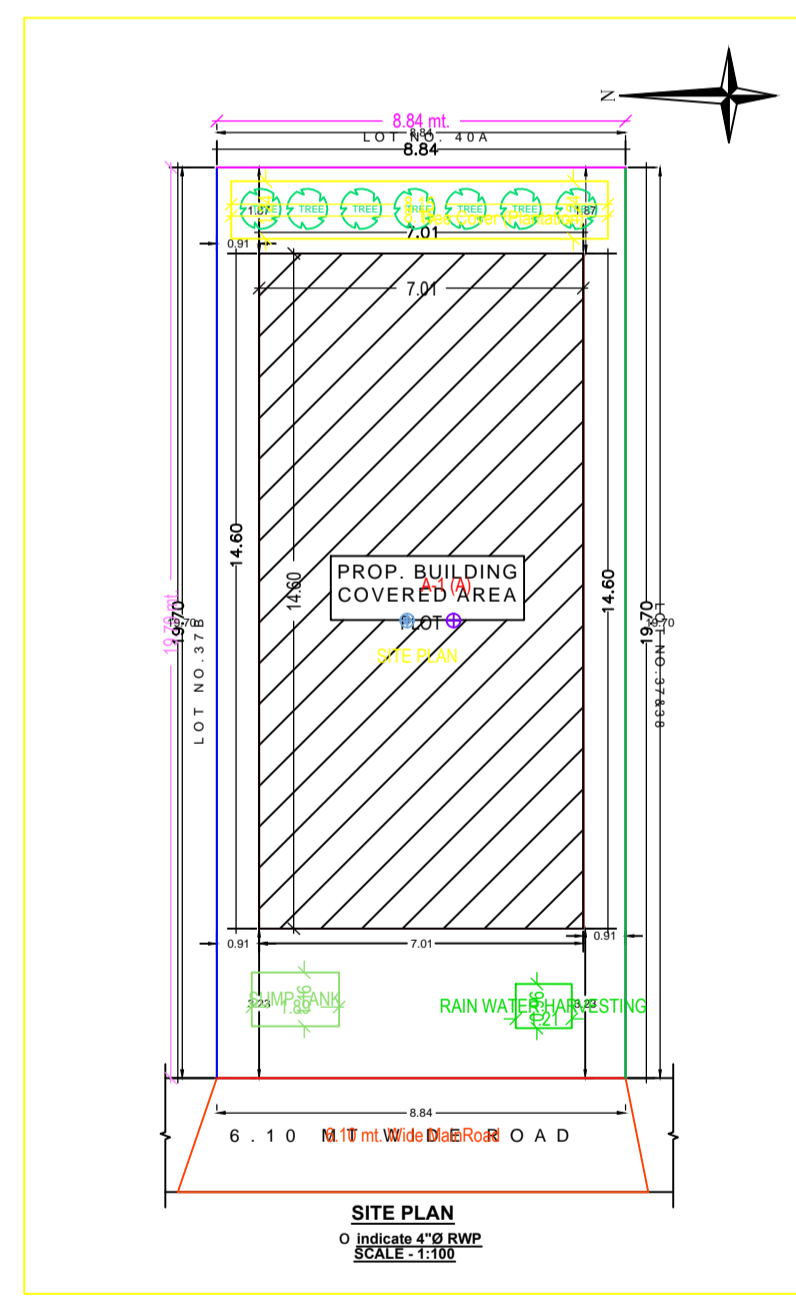
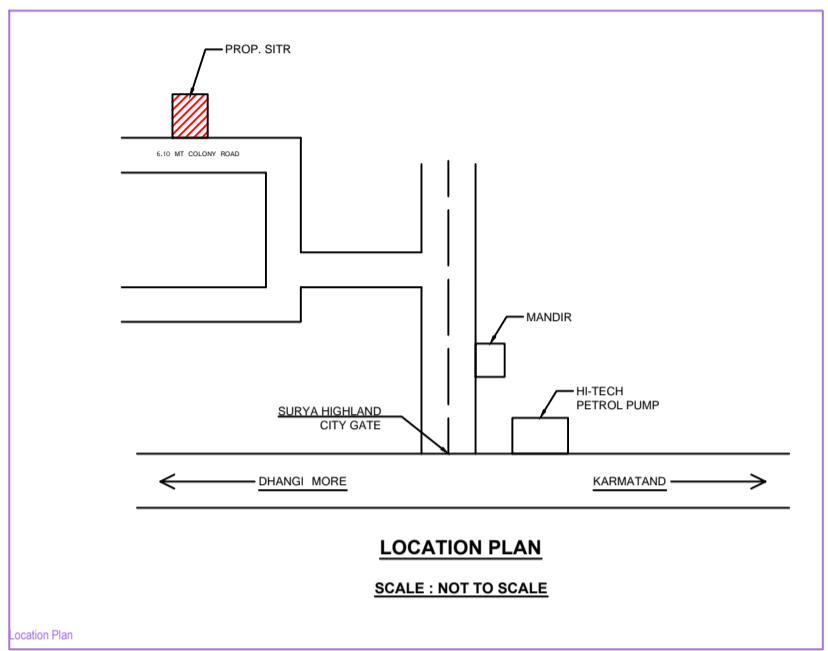
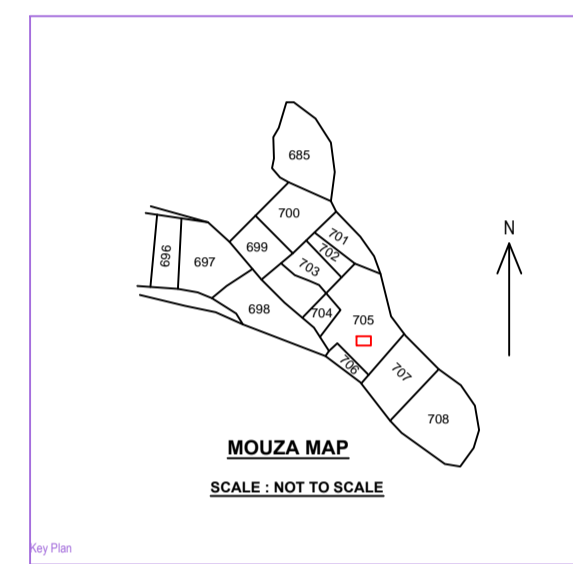
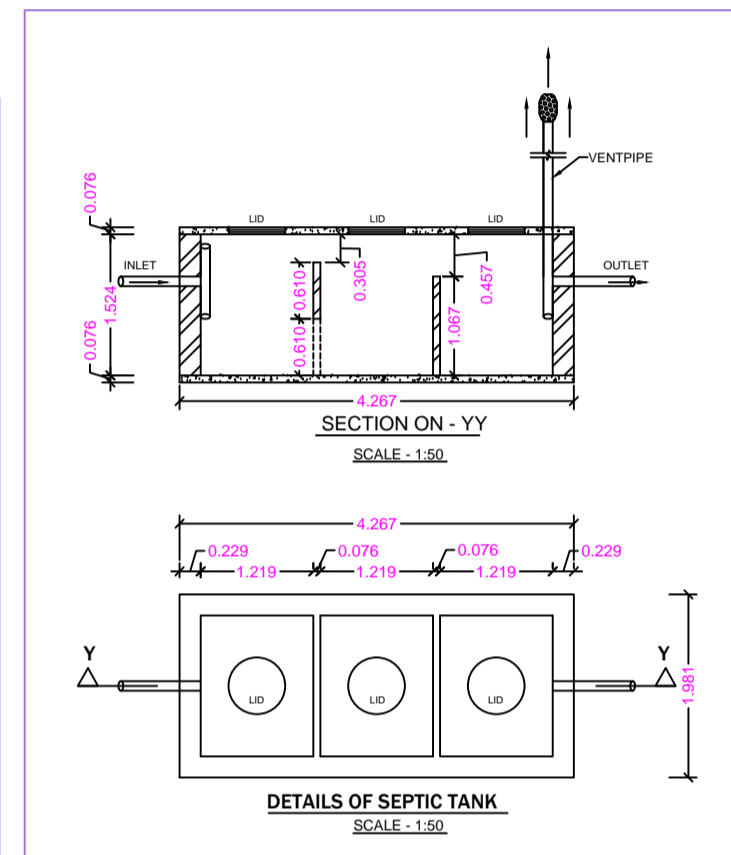
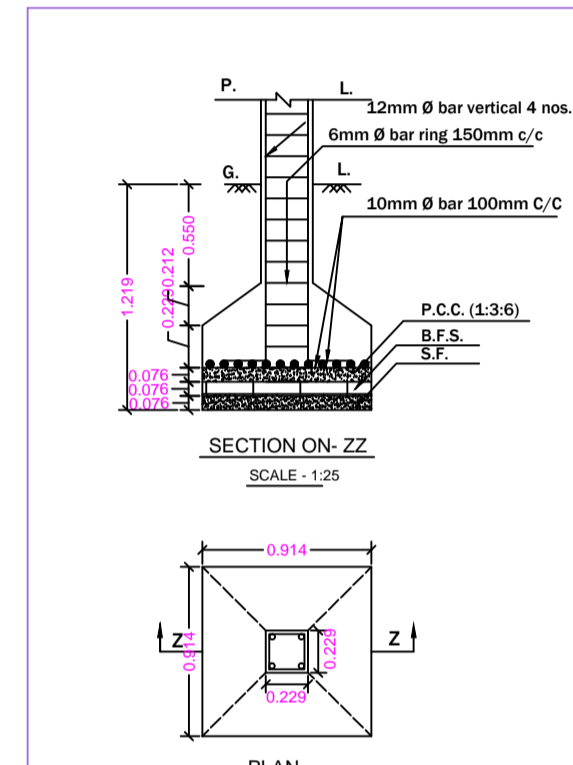
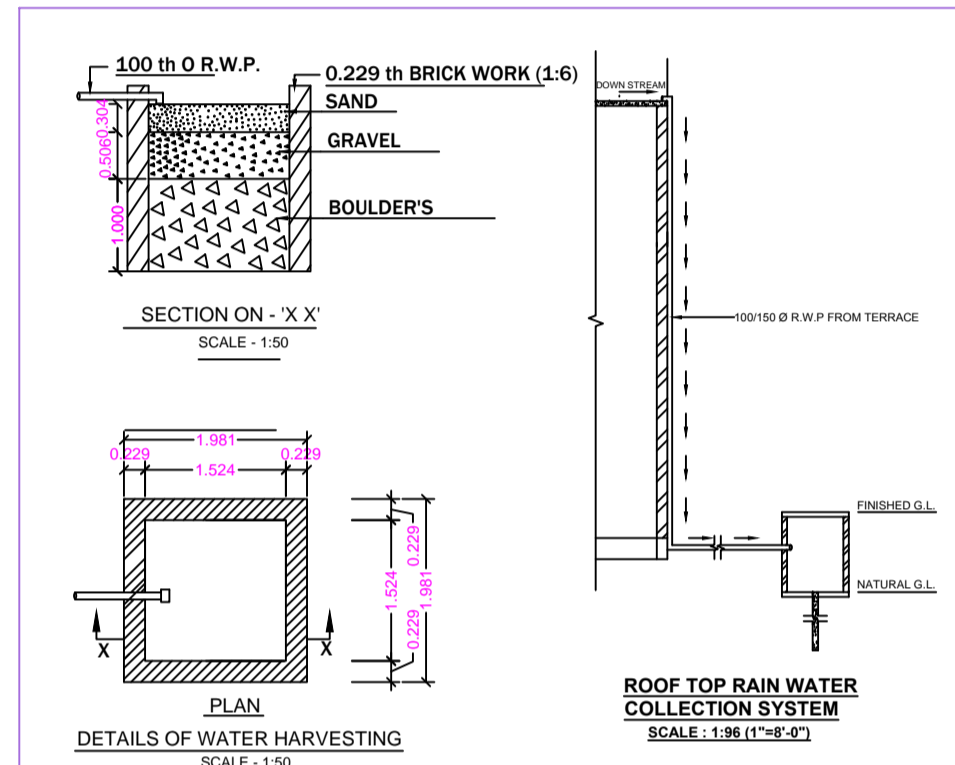
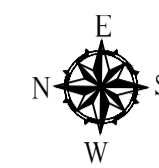
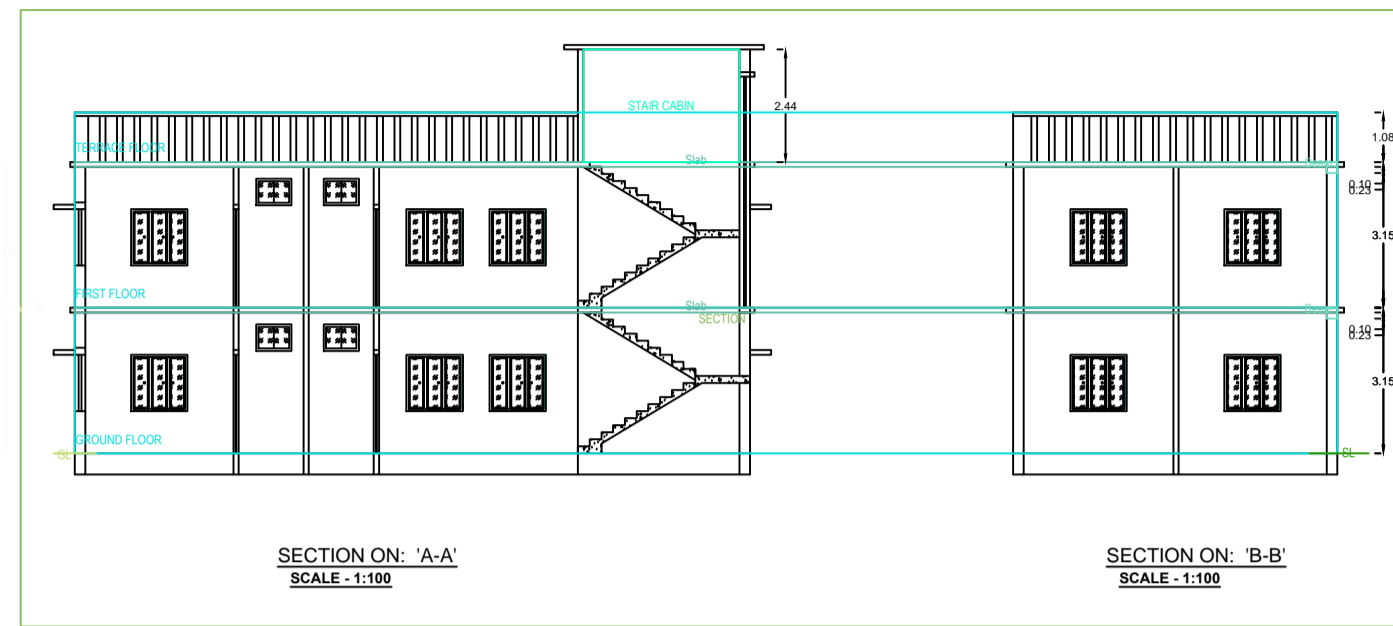
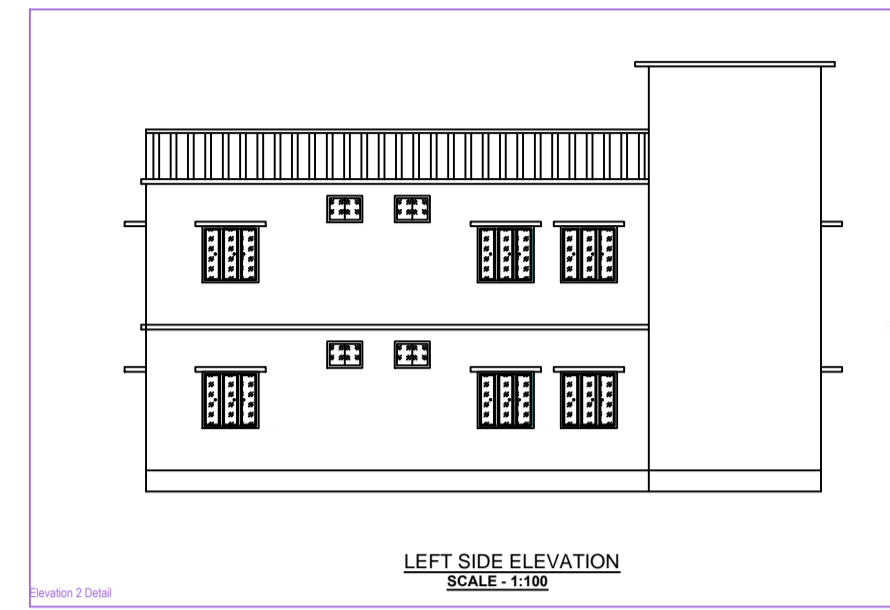
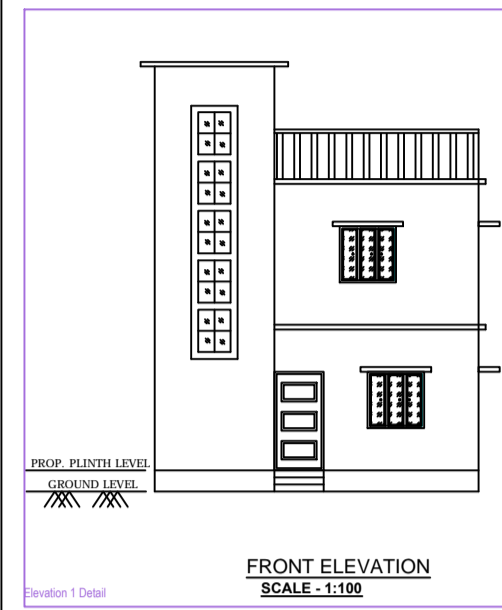

### BRIEF SPECIFICATION

**FOUNDATION** -> R.C.C. (1:1.5:3) Column footing foundation.  
**PLINTH** -> 304mm th R.C.C. (1:1.5:3) all round on plinth level.  
**FLOORING** -> 40mmth Marble, flooring over 3"th P.C.C. (1:3:6).  
**SUPER STRUCTURE** - First class brick work in cement mortar (1:6).  
**SLAB, BEAM & LINTEL** - All R.C.C. work (1:1.5:3).  
**WOOD WORK** - All doors & windows frames of Sal wood  
**PLASTERING** -> 12mm cement plaster (1:6) both side.

### SCHEDULE

D - 1.067X2.134	W - 1.524X1.219
D1 - 0.914X2.134	W1 - 1.219X1.219
	V - 0.914X0.610

### DETAILS OF AREA

1) LAND AREA (AS DEED):	174.72 Sq.M
2) LAND AREA (AS PER SITE):	174.14 Sq.M
3) GROUND FLOOR AREA:	102.38 Sq.M
4) FIRST FLOOR AREA:	102.38 Sq.M
5) COVERED AREA:	204.76 Sq.ft.
6) % OF PLINTH AREA:	68.79 %
7) F.A.R.:	1.17

### TITLE OF DRAWING

PROPOSED RESIDENTIAL BUILDING PLAN OF SRI RAJIV RANJAN S/O HARI MANGAL SINGH ON PLOT NO. -OLD-768 & 769 NEW- 705 UNDER KHATA NO OLD-34 NEW- 60 IN MOUZA - NARAYANPUR, MOUZA NO 13 IN DISTRICT OF D H A N B A D J H A R K H A N D

### SIG. OF OWNER

### SIG. OF ENGINEER

Building -A (A)

Floor Name	Total Built Up Area (Sq.m)	Proposed FAR Area (Sq.m)	Total FAR Area (Sq.m)	Trent (No.)
Ground Floor	102.38	102.38	102.38	01
FIRST FLOOR	102.38	102.38	102.38	01
TERRACE FLOOR	0.00	0.00	0.00	00
<b>Total</b>	<b>204.76</b>	<b>204.76</b>	<b>204.76</b>	<b>01</b>
Total Number of Same Buildings	1			
TOTL	204.76	204.76	204.76	01

SCHEDULE OF JOINERY:

BUILDING NAME	NAME	LENGTH	HEIGHT	MOS
A(A)	D	0.76	2.13	06
	P(A)	0.91	2.13	09
	P(A)	1.87	2.13	09
	TERR	-	-	17

SCHEDULE OF JOINERY:

BUILDING NAME	NAME	LENGTH	HEIGHT	MOS
A(A)	V	0.76	1.00	06
	W	1.82	1.25	20
	TERR	-	-	26

Unit/BUA Table for Building -A (A)

FLOOR	Name	UNIT/BUA Type	UNIT/BUA Area	Carpet Area	No. of Rooms	No. of Treatment
GROUND FLOOR PLAN	SPLIT A	FLAT	204.76	204.68	10	1
			204.76	204.68	20	1

AREA STATEMENT MINERAL AREA DEVELOPMENT AUTHORITY	VERSION NO. - 1.01
PROJECT DETAIL	VERSION DATE: 09/02/20
TRACT No.:	Plot No. Residential
Region - JHARKHAND URBAN LOCAL BODIES	Plot Subtype - Bungalow/Dwelling / Non-Apartment
District - GHANSAI	Land Use Zone - NA
Application Type - General Proposal	Planning Zone - NA
Project Type - Building Permission	Plot No. -
Nature of Development - New	Platform Survey No/Survey No -
Location - Old Area	Thana No. -
S/O Location - NA	Holding No. -
Village/Mouza Name -	Block No. -
Ward No. -	North -
Roadname -	South -
	East -
	West -

AREA DETAILS:	UNIT	SQ.MT
AREA OF PLOT (Minimum)	(A)	174.14
Net Plot Area (Gross Plot Area - (A) Deductions)		174.14
Deductions for Balance Plot Area (from Gross Plot Area)		0.00
<b>Total</b>		<b>174.14</b>
Balance Plot Area (Net Plot Area - Recreational/Amenity space)	(A) Deductions	164.00
Plot Area for Coverage (Net Plot Area)	(A) Deductions	174.14
Plot Area for PFI (Net Plot Area + Road/Water Area)	(A) Deductions	174.14
<b>COVERAGE CHECK</b>		
Proposed Coverage Area (100 %)		102.38
Yield Coverage Area (100 %)		102.38
<b>FAR CHECK</b>		
Proposed Area of FAR		204.76
Total Area of FAR		204.76
<b>BUILT UP AREA CHECK</b>		
Yield Proposed Built Up Area		204.76
ARCHT ENGRG SUPERVISOR (Regd)		OWNER
DEVELOPMENT AUTHORITY		LOCAL BODY

COLOR INDEX					
Plot Boundary					
Abutting Road					
Proposed Work (Coverage Area)					
Existing (To be retained)					
Existing (To be demolished)					

Color Index					
Building Wing	Front Margin	Rear Margin	Side Margin	Setback	Setback
A (A)	2.27	1.87	0.31	0.91	0.91

FAR & Tancement Details (Table A-1)					
Building	No. of Same Bldg	Total Built Up Area (Sq.m)	Proposed FAR Area (Sq.m)	Total FAR Area (Sq.m)	Trent (No.)
A(A)	1	204.76	204.76	204.76	01
<b>Grand Total</b>	<b>1</b>	<b>204.76</b>	<b>204.76</b>	<b>204.76</b>	<b>01</b>