

Proposal Basic Information

Proposal File No.	MADA/BP/0050/2024
Owner Name	SRI. VIKASH PANDEY
Khata No	OLD KHATA NO-10, NEW KHATA NO-133
Plot No	OLD PLOT NO-502, NEW PLOT NO-1446
Village Name	Jialgora
Use	Residential
SubUse	Bungalow/ Dwelling / Non Apartment

AREA STATEMENT MINERAL AREA DEVELOPMENT AUTHORITY

VERSION NO.: 1.0.68
VERSION DATE: 16/10/2020

PROJECT DETAIL:	
LOCAL BODIES	Plot Use: Residential
District: DHANBAD	Plot SubUse: Bungalow/ Dwelling / Non Apartment
Authority: MINERAL AREA DEVELOPMENT AUTHORITY	PlotNearby/Religious/Structure: NA
Inward No: MADA/BP/0050/2024	Plot/SubPlot No: OLD PLOT NO-502, NEW PLOT NO-1446
Application Type: General Proposal	North: Plot No. - SAME PLOT
Project Type: Building Permission	South: Plot No. - SAME PLOT
Nature of Development: New	East: Plot No. - SAME PLOT
Location of Development Area: Old Area	West: Road Width - 6.10
AREA DETAILS:	SQ.MT.
AREA OF PLOT (Minimum)	(A) 152.53
NET AREA OF PLOT(Gross Plot Area - Deduction from Gross Plot area)	(A-Deductions) 152.53
Deduction for Balance Plot Area(from Gross Plot Area)	
Common Plot	17.32
Total	17.32
BALANCE AREA OF PLOT(Net Plot Area - Recreational/Amenity space)	(A-Deductions) 135.21
PLOT AREA FOR COVERAGE(Net Plot Area)	(A-Deductions) 152.53
Plot Area for FAR (Net Plot Area + RoadWidening Area)	(A-Deductions) 152.53
COVERAGE CHECK	
Permissible Coverage area (70.00 %)	106.77
Proposed Coverage Area (49.04 %)	74.80
Total Prop. Coverage Area (49.04 %)	74.80
Balance coverage area (20.96 %)	31.97
FAR CHECK	
Perm. FAR Area (2.500)	381.33
Total Perm. FAR area	381.33
Residential FAR	164.46
Proposed FAR Area	164.46
Total Proposed FAR Area	164.46
Consumed FAR (Factor)	1.08
Balance FAR Area	216.87
BUILT UP AREA CHECK	
Total Proposed BuiltUp Area	180.25
ARCHITECT (Regd)	RAM PRATAP SINGH
ENGINEER (Regd)	
SUPERVISOR (Regd)	
OWNER (Regd)	SRI. VIKASH PANDEY
DEVELOPMENT AUTHORITY	LOCAL BODY

UnitBUA Table for Building :A (VIKASH)

FLOOR	Name	UnitBUA Type	UnitBUA Area	Carpet Area	No. of Rooms	No. of Tenement
GROUND FLOOR PLAN	SPLIT 1	FLAT	147.39	147.32	6	1
FIRST FLOOR PLAN	SPLIT 1	FLAT	0.00	0.00	7	0
Total:	-	-	147.39	147.32	13	1

SCHEDULE OF DOOR:

BUILDING NAME	NAME	LENGTH	HEIGHT	NOS
A (VIKASH)	D	0.97	2.10	06
A (VIKASH)	D	1.07	2.10	01
A (VIKASH)	D	1.08	2.10	04
A (VIKASH)	D	1.16	2.10	01
A (VIKASH)	D	1.21	2.10	01

SCHEDULE OF WINDOW/VENTILATION:

BUILDING NAME	NAME	LENGTH	HEIGHT	NOS
A (VIKASH)	V	0.61	1.20	01
A (VIKASH)	W1	0.98	1.20	01
A (VIKASH)	V	1.13	1.20	01
A (VIKASH)	W1	1.22	1.20	02
A (VIKASH)	V	1.22	1.20	02
A (VIKASH)	W	1.51	1.20	01
A (VIKASH)	W	1.52	1.20	12

Building :A (VIKASH)

Floor Name	Total Built Up Area (Sq.mt)	Deductions (Area in Sq.mt)	Proposed FAR Area (Sq.mt)	Total FAR Area (Sq.mt)	Total Consumed Additional FAR Area (Sq.mt)	Tnmt (No.)
Ground Floor	90.59	15.79	74.80	74.80	74.80	01
First Floor	89.66	0.00	89.66	89.66	89.66	00
Terrace Floor	0.00	0.00	0.00	0.00	0.00	00
Total:	180.25	15.79	164.46	164.46	164.46	01
Total Number of Same Buildings	1					
Total:	180.25	15.79	164.46	164.46	164.46	01

COLOR INDEX

PLOT BOUNDARY	Black
ABUTTING ROAD	Red
PROPOSED CONSTRUCTION	Green
COMMON PLOT	Blue
ROAD WIDENING AREA	Yellow
EXISTING (To be retained)	Light Blue
EXISTING (To be demolished)	Light Yellow

Buildingwise Floor FAR Details

Floor Name	Building Name A (VIKASH)		Total	
	Proposed Built Up Area (Sq.mt)	Proposed FAR Area (Sq.mt)	Total Proposed Built Up Area (Sq.mt)	Total FAR Area (Sq.mt)
Ground Floor	90.59	74.80	90.59	74.80
First Floor	89.66	89.66	89.66	89.66
Terrace Floor	0.00	0.00	0.00	0.00
Total:	180.25	164.46	180.25	164.46

Building USE/SUBUSE Details

Building Name	Building Use	Building SubUse	Building Structure
A (VIKASH)	Residential	Bungalow/ Dwelling / Non Apartment	Non-Highrise

FAR & Tenement Details (Table 4c-1)

Building	No. of Same Bldg	Total Built Up Area (Sq.mt)	Deductions (Area in Sq.mt)	Proposed FAR Area (Sq.mt)	Total FAR Area (Sq.mt)	Total Consumed Additional FAR Area (Sq.mt)	Tnmt (No.)
A (VIKASH)	1	180.25	15.79	164.46	164.46	164.46	01
Grand Total:	1	180.25	15.79	164.46	164.46	164.46	01

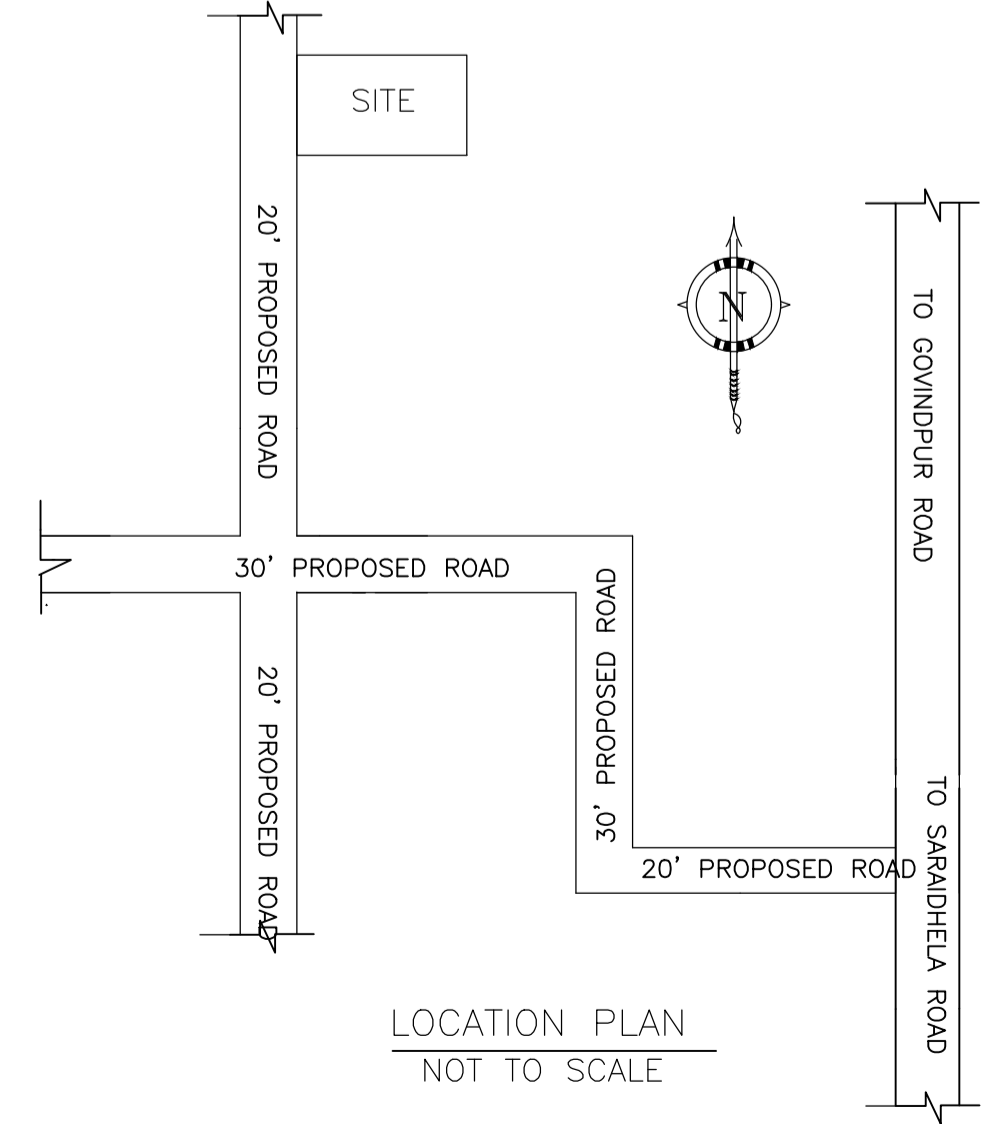
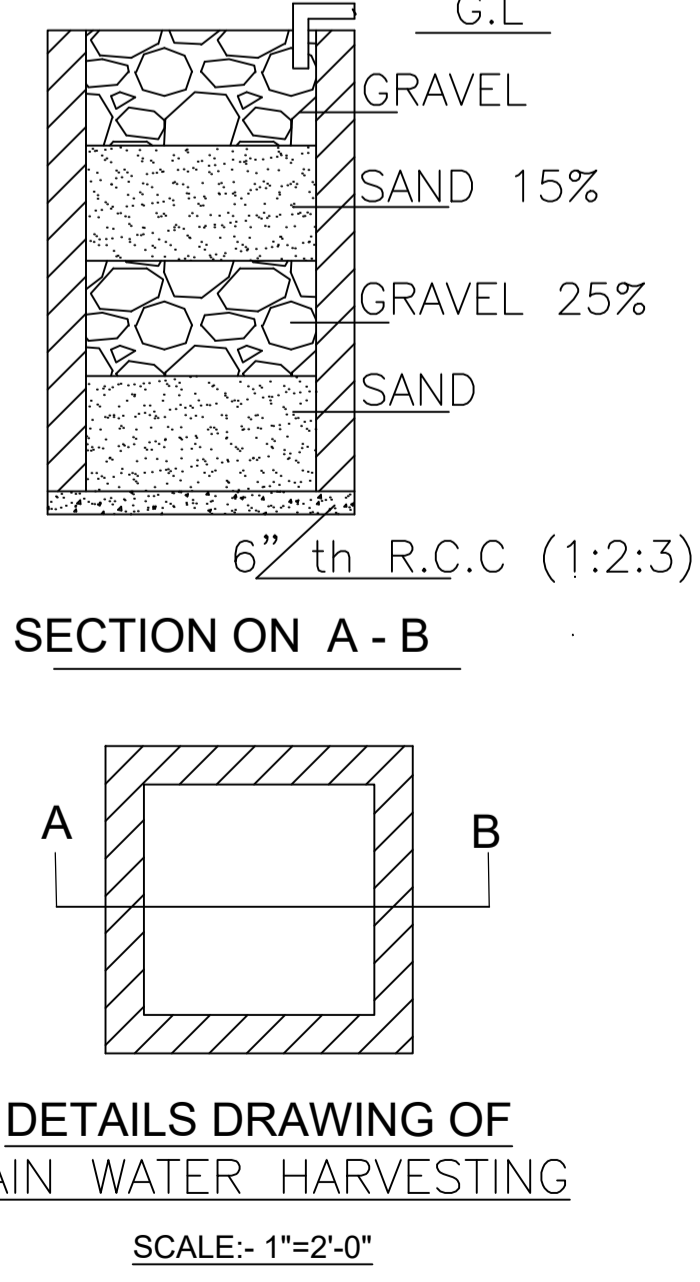
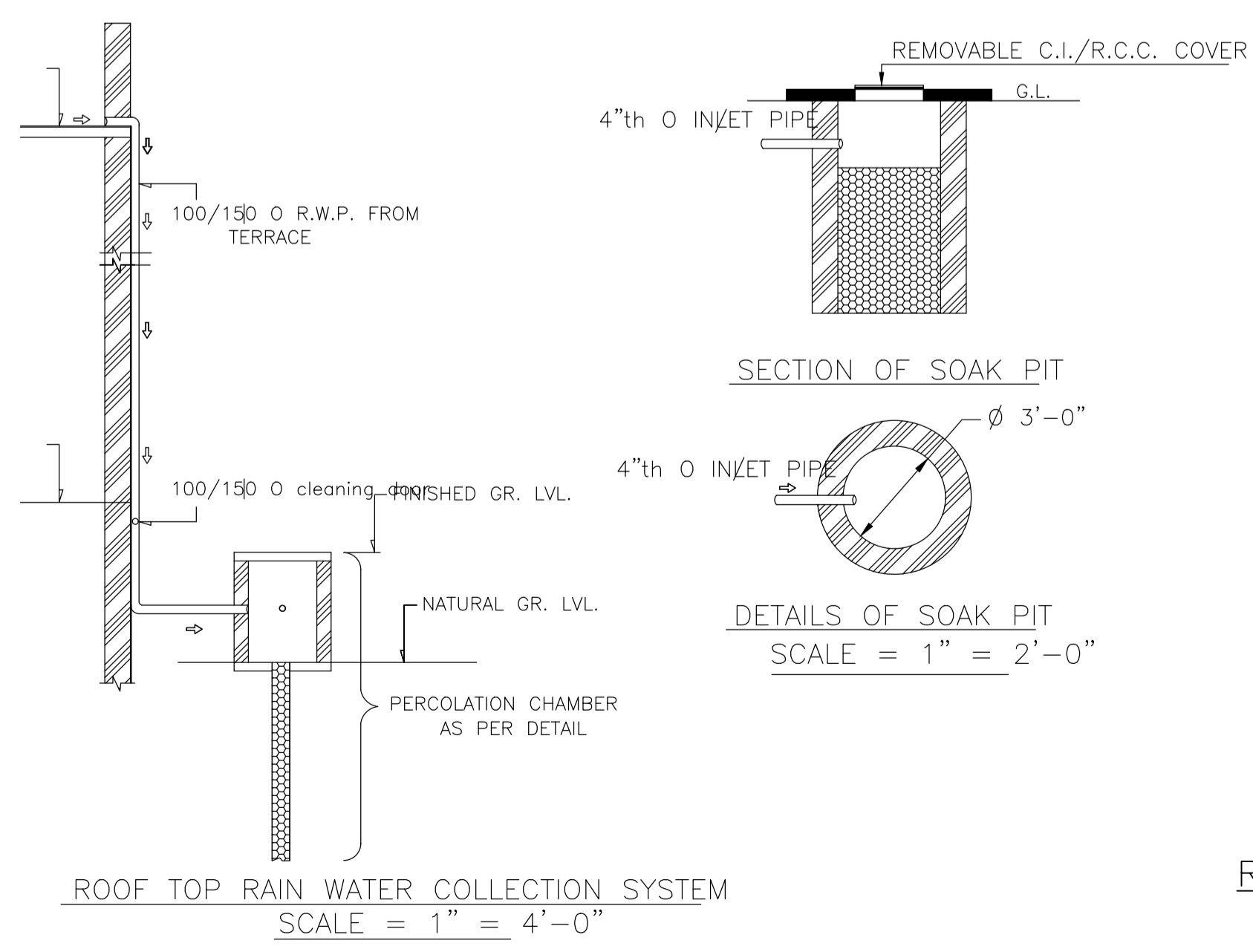

LTP NAME AND SIGNATURE	STRUCTURAL ENG'S NAME AND SIGNATURE	BUILDER NAME AND SIGNATURE	DIGITAL SIGNATURE
RAM PRATAP SINGH MADA/ARC/0024/2019			

Proposal Basic Information	
Proposal File No.	MADA/BP/0050/2024
Owner Name	SRI. VIKASH PANDEY
Khata No	OLD KHATA NO-10, NEW KHATA NO-133
Plot No	OLD PLOT NO-502, NEW PLOT NO-1446
Village Name	Jialgora
Use	Residential
SubUse	Bungalow/ Dwelling / Non Apartment

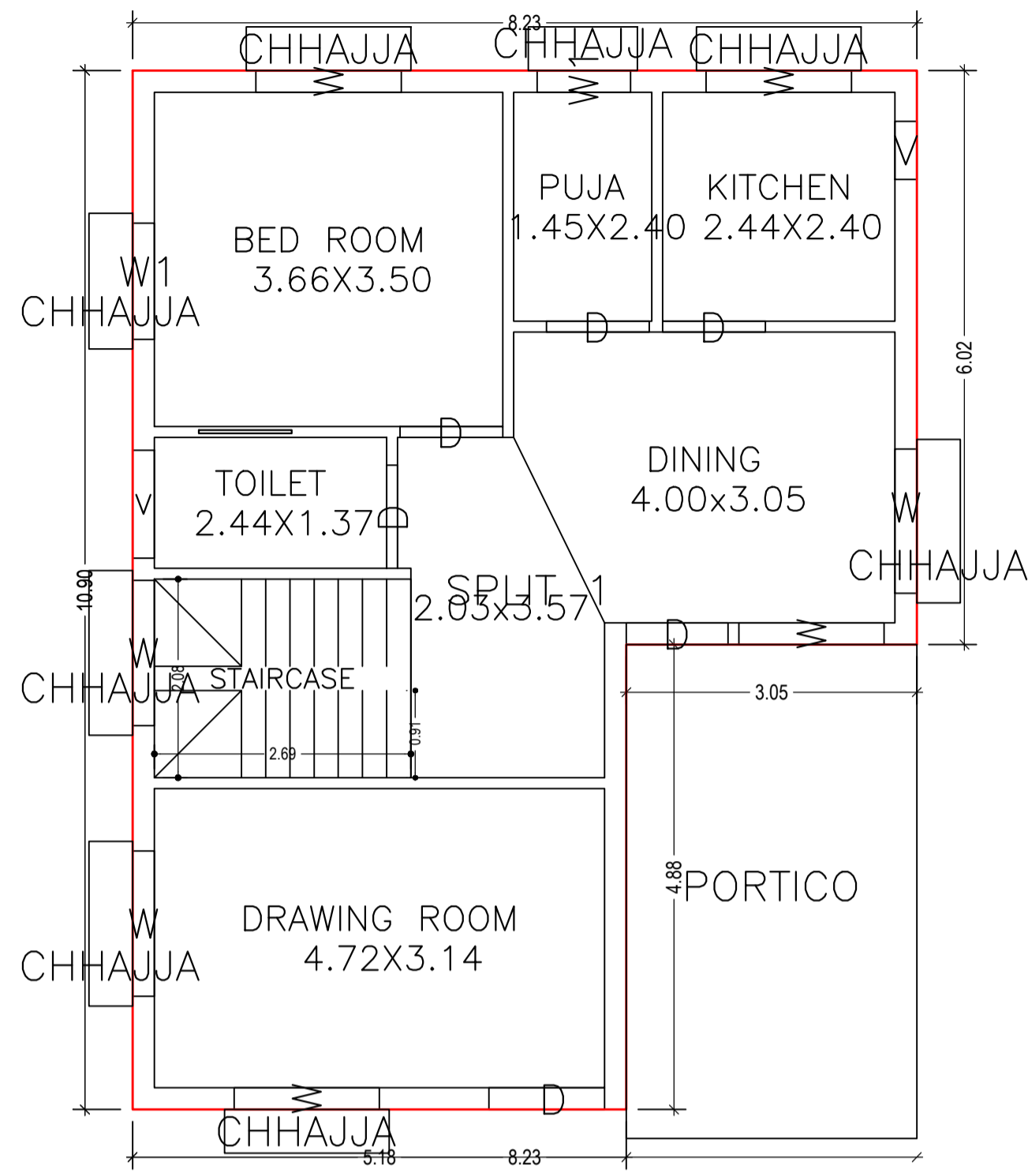

GROUND FLOOR PLAN
(Proposed)
(SCALE 1:100)

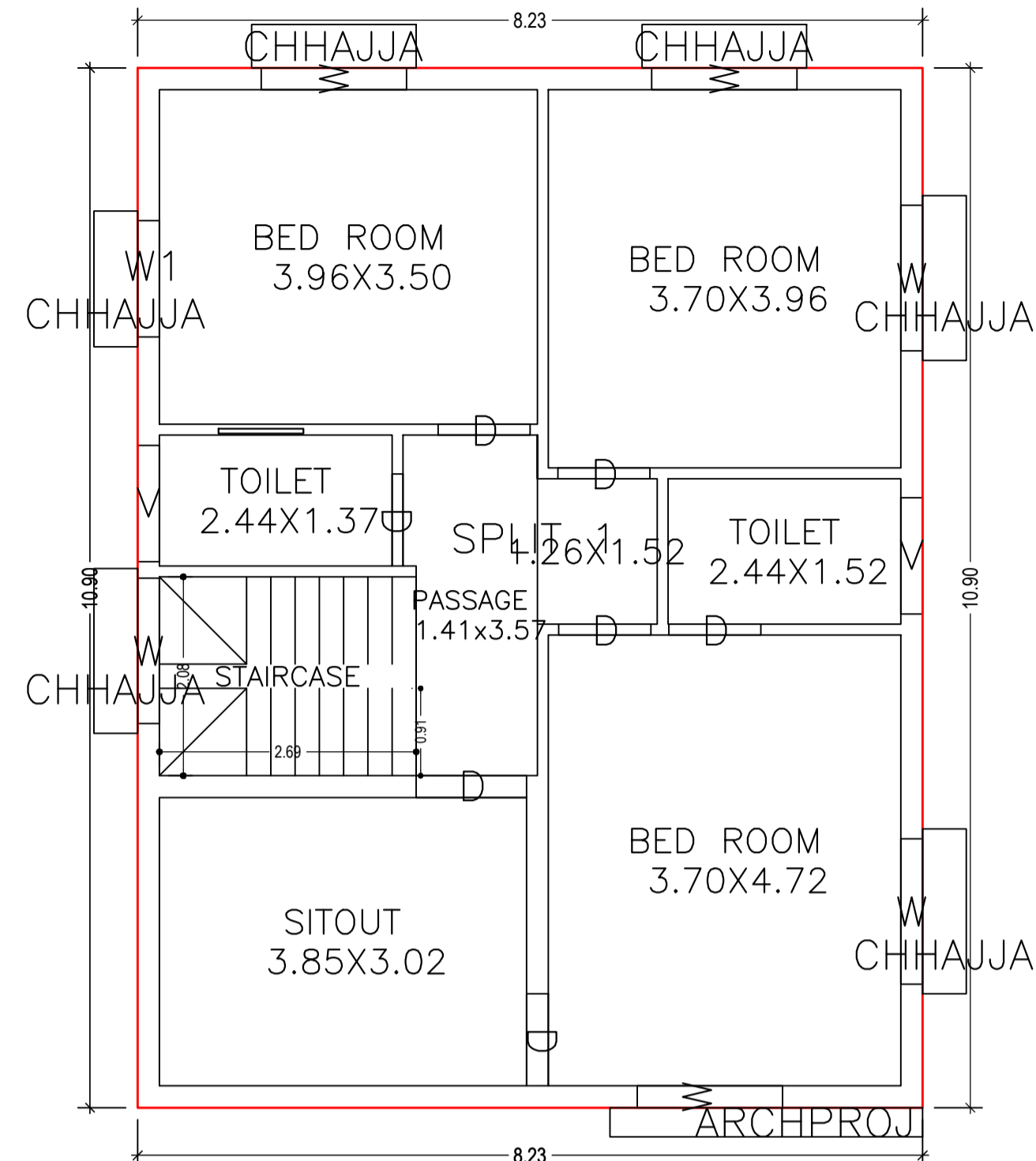

FIRST FLOOR PLAN
(Proposed)
(SCALE 1:100)

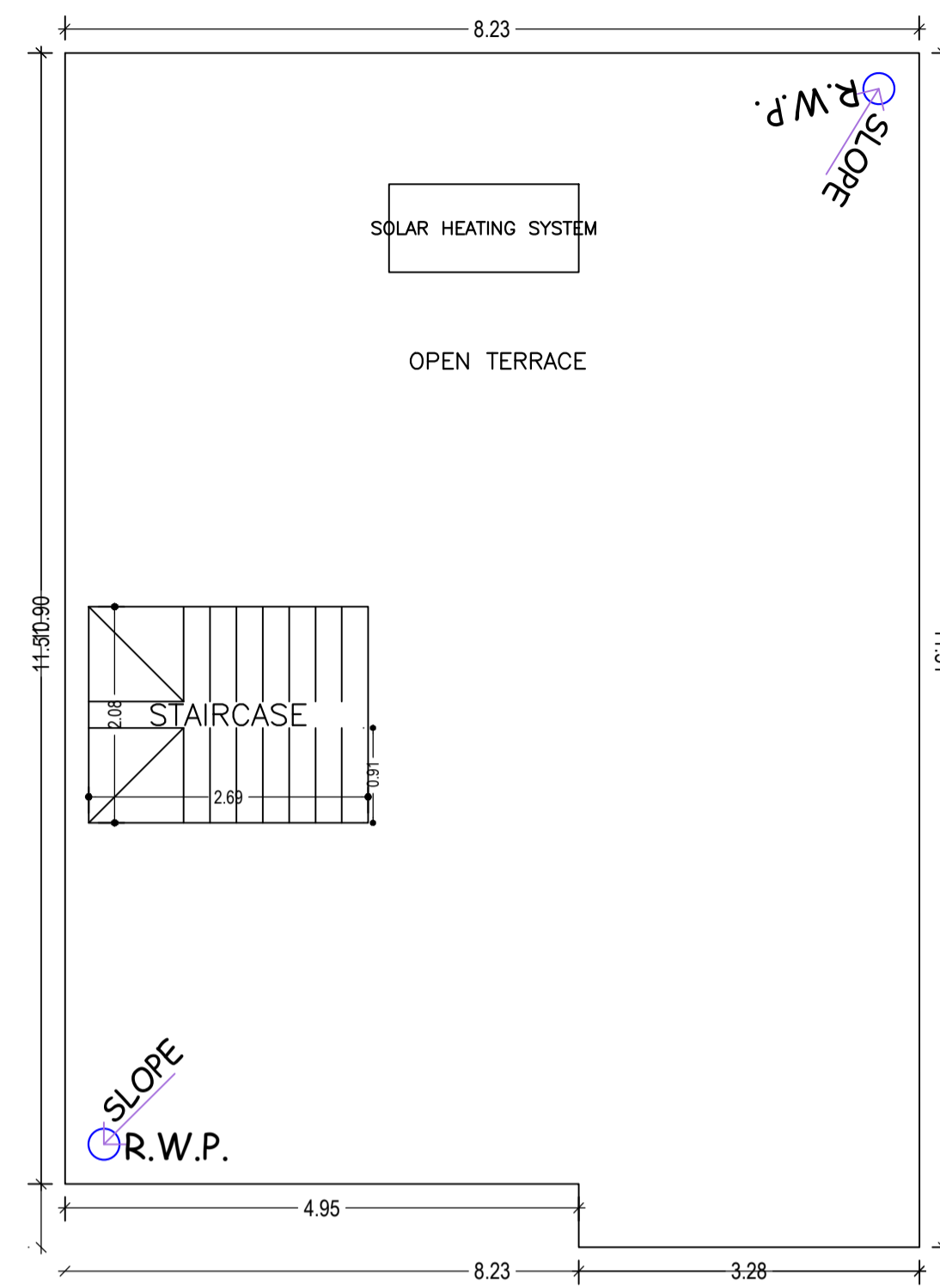

TERRACE FLOOR PLAN
(SCALE 1:100)

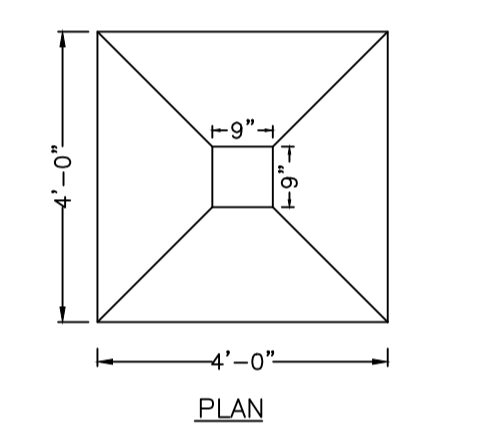
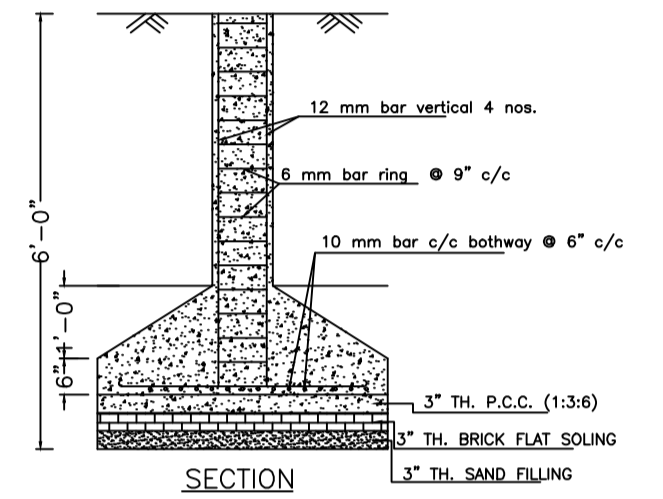
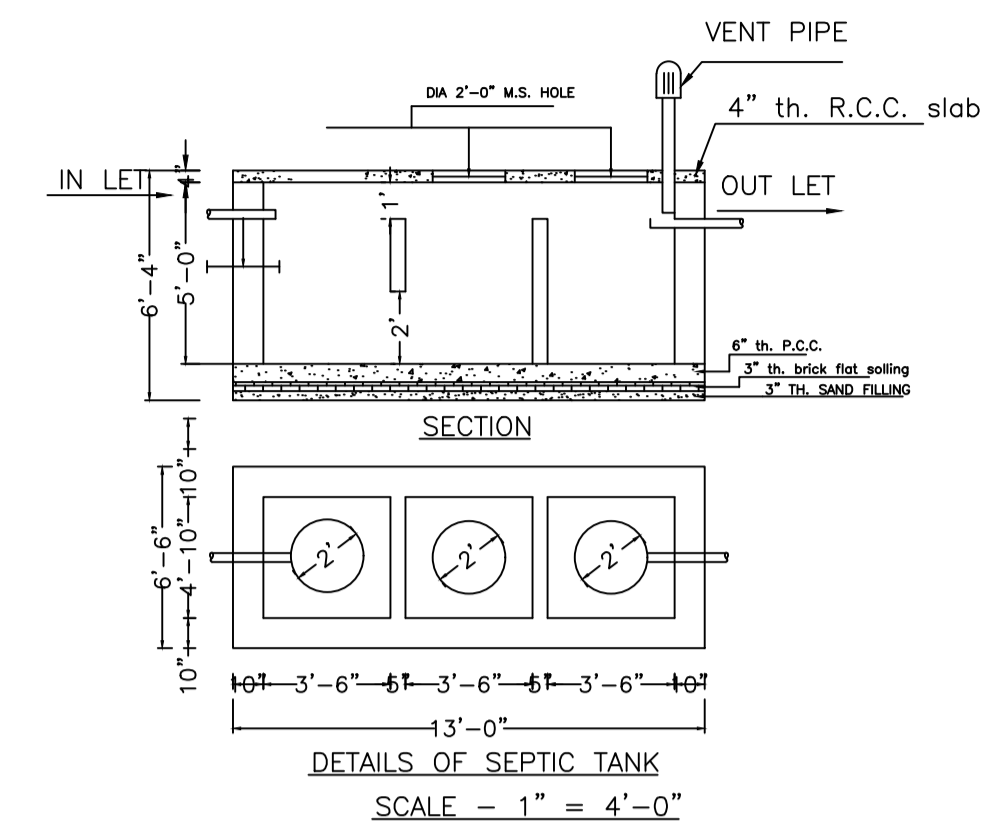

DETAILS OF COLUMN FOUNDATION
SCALE - 1" = 2'-0"

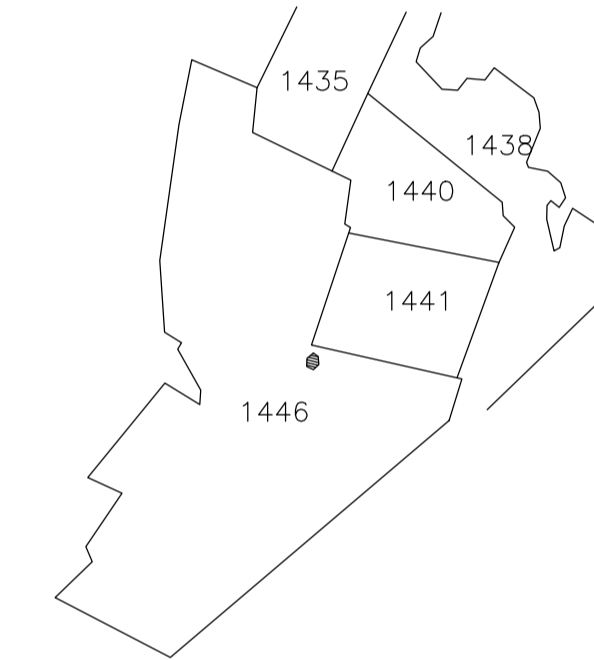

KEY PLAN

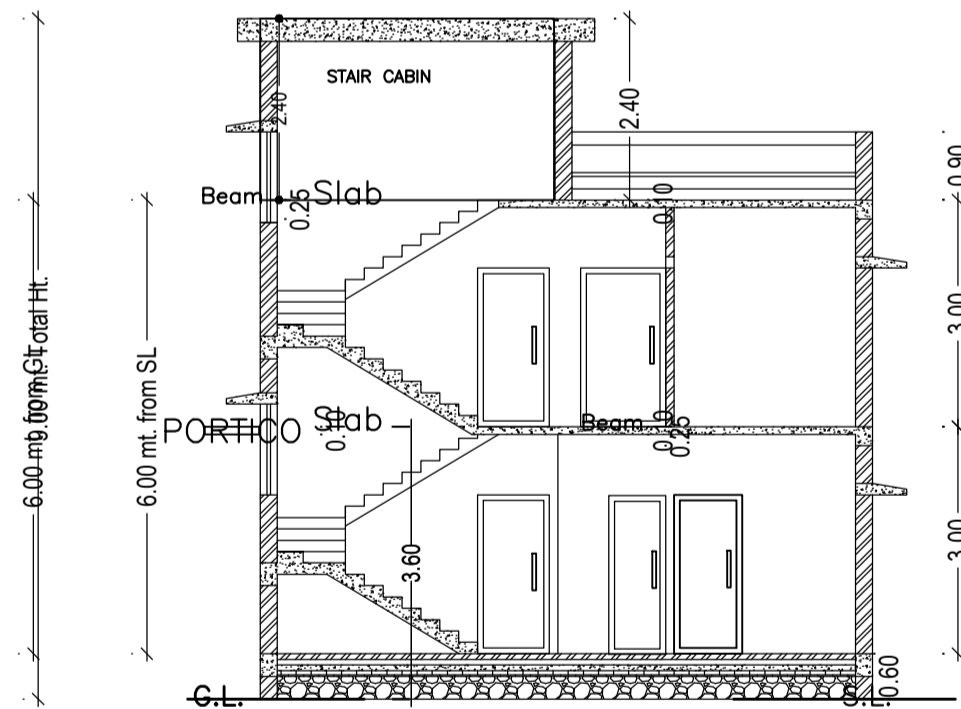

SECTION - XX'
SCALE - 1" = 8'-0"

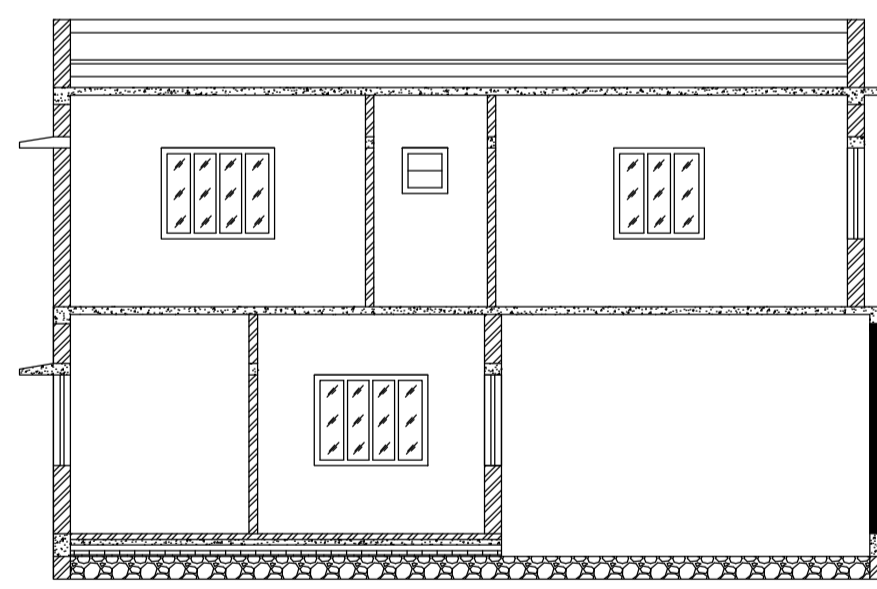

SECTION - YY'
SCALE - 1" = 8'-0"

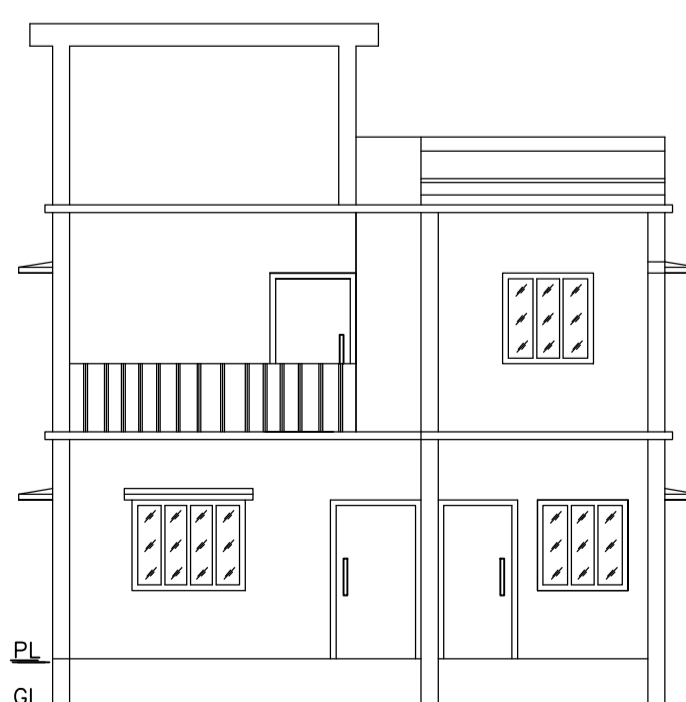

FRONT ELEVATION
SCALE - 1" = 8'-0"

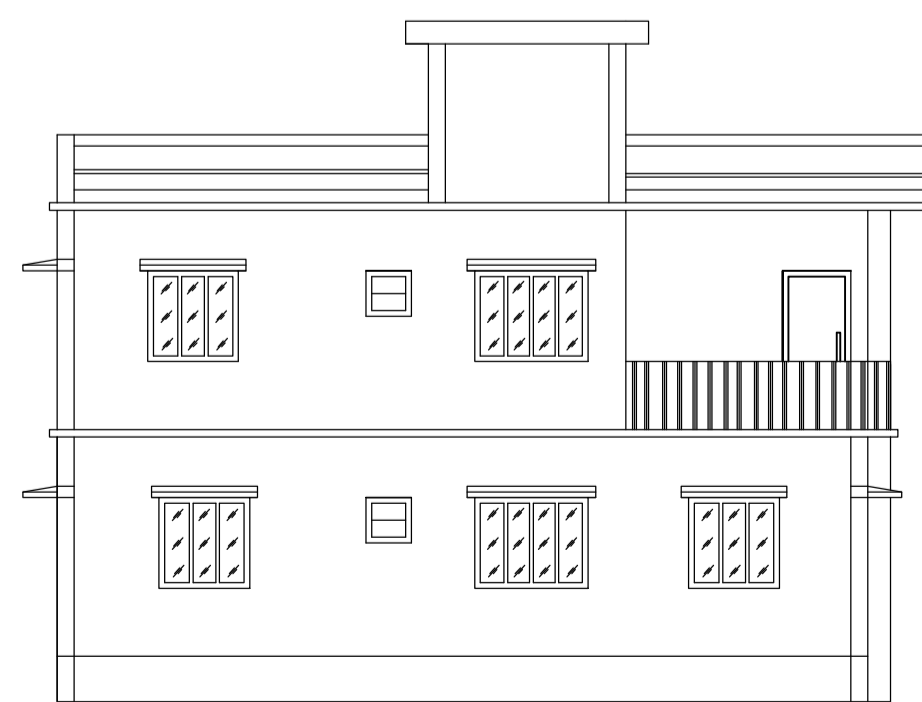

LEFT SIDE ELEVATION
SCALE - 1" = 8'-0"

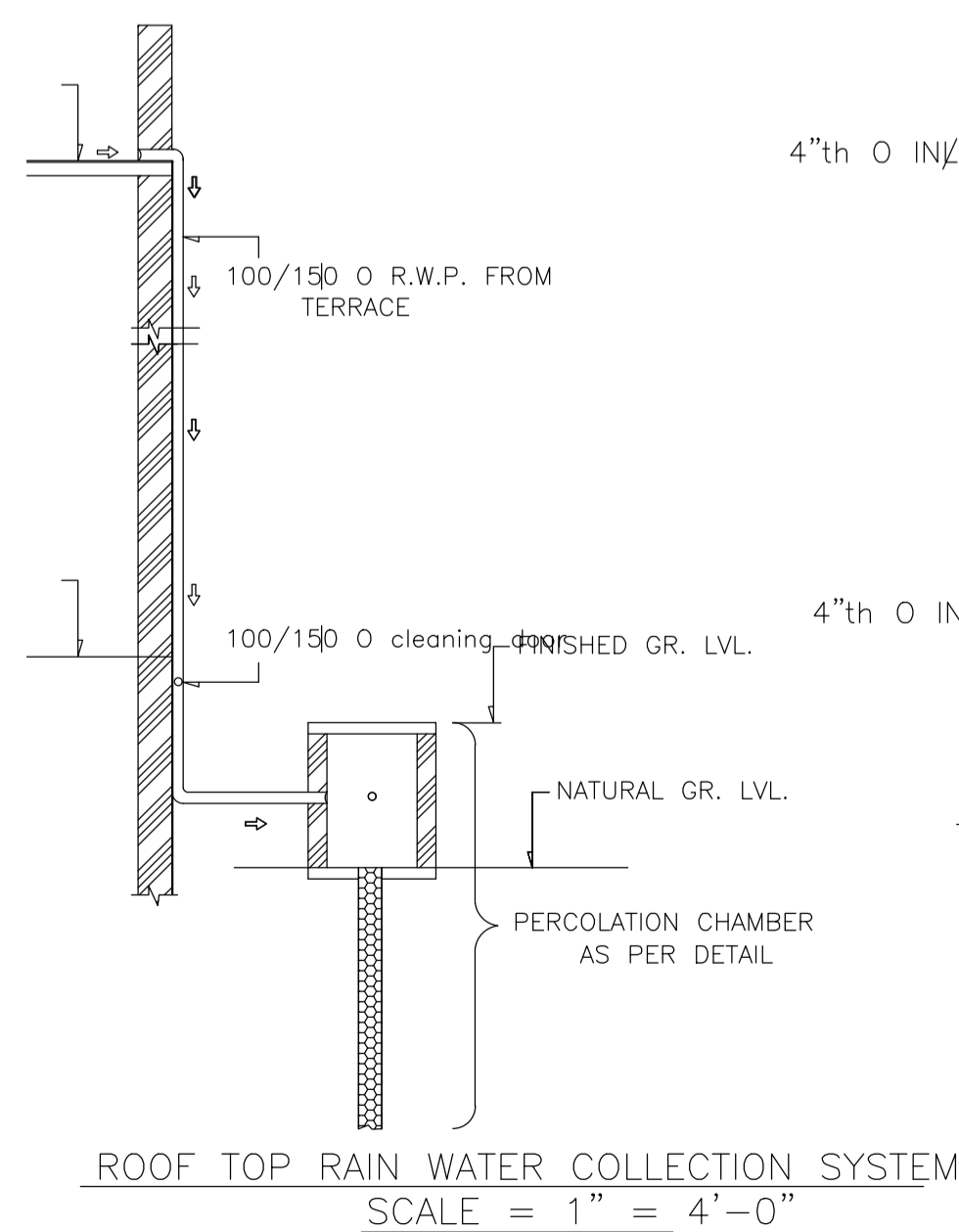

ROOF TOP RAIN WATER COLLECTION SYSTEM
SCALE = 1" = 4'-0"

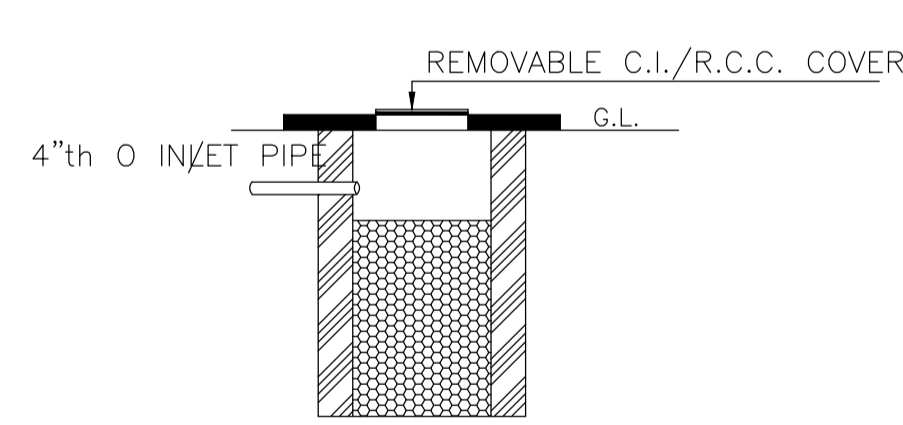

SECTION OF SOAK PIT

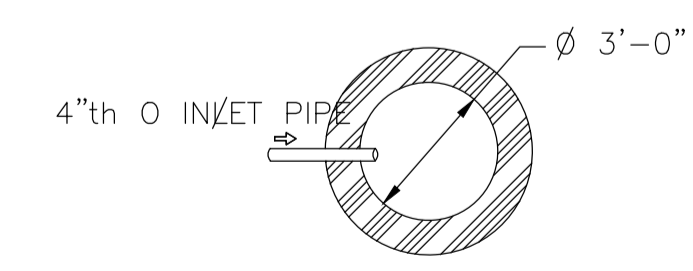

DETAILS OF SOAK PIT
SCALE = 1" = 2'-0"

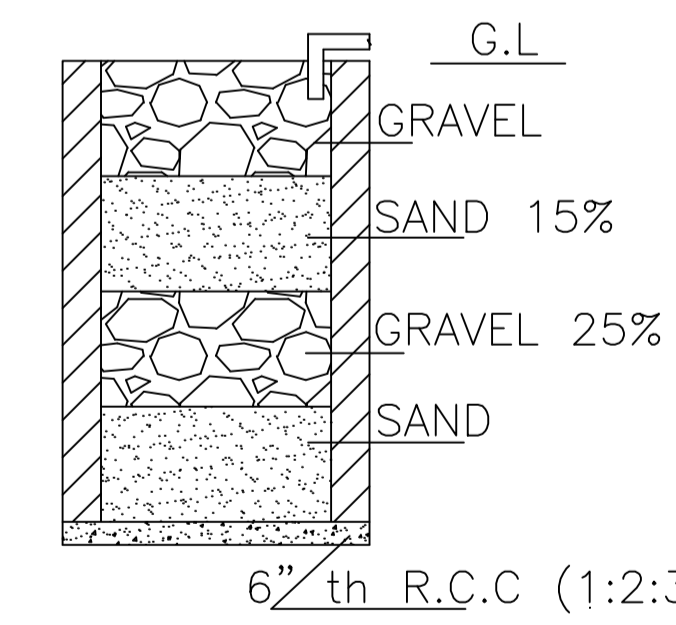

SECTION ON A - B

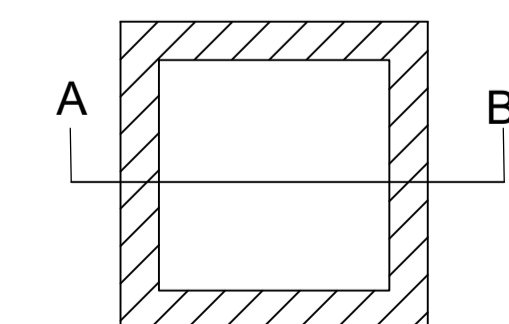

DETAILS DRAWING OF RAIN WATER HARVESTING
SCALE:- 1"=2'-0"

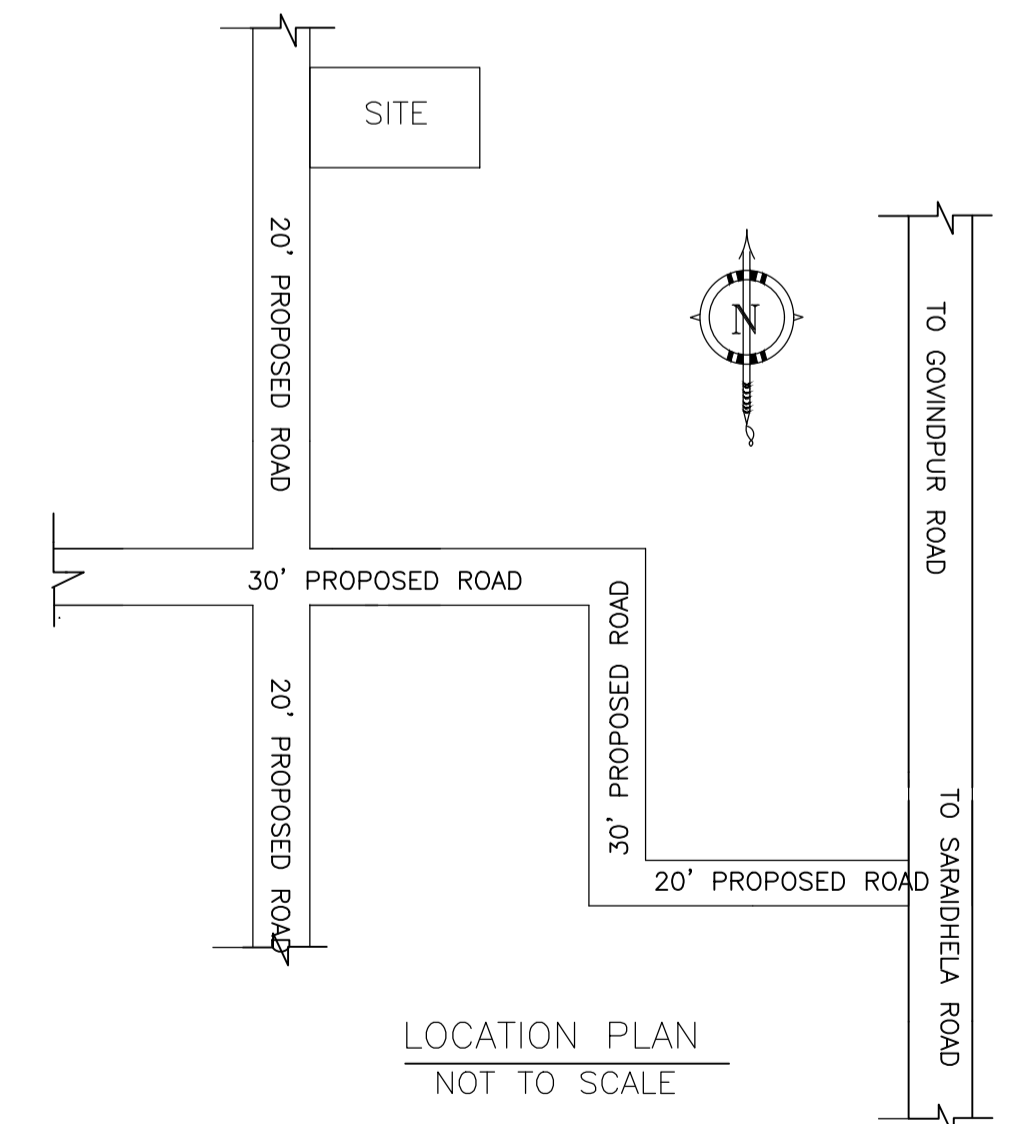

LOCATION PLAN
NOT TO SCALE

LTP NAME AND SIGNATURE	STRUCTURAL ENG'S NAME AND SIGNATURE	BUILDER NAME AND SIGNATURE	DIGITAL SIGNATURE
RAM PRATAP SINGH MADA/ARC/0024/2019			