

Proposal Basic Information	
Proposal File No.	MADA/BP/0264/2024
Owner Name	SRI SANJAY KUMAR SINGH
Khata No	NEW - 96, OLD - 12
Plot No	NEW - 223, OLD - 136
Village Name	Gosaidh
Use	Residential
SubUse	Bungalow/ Dwelling / Non Apartment

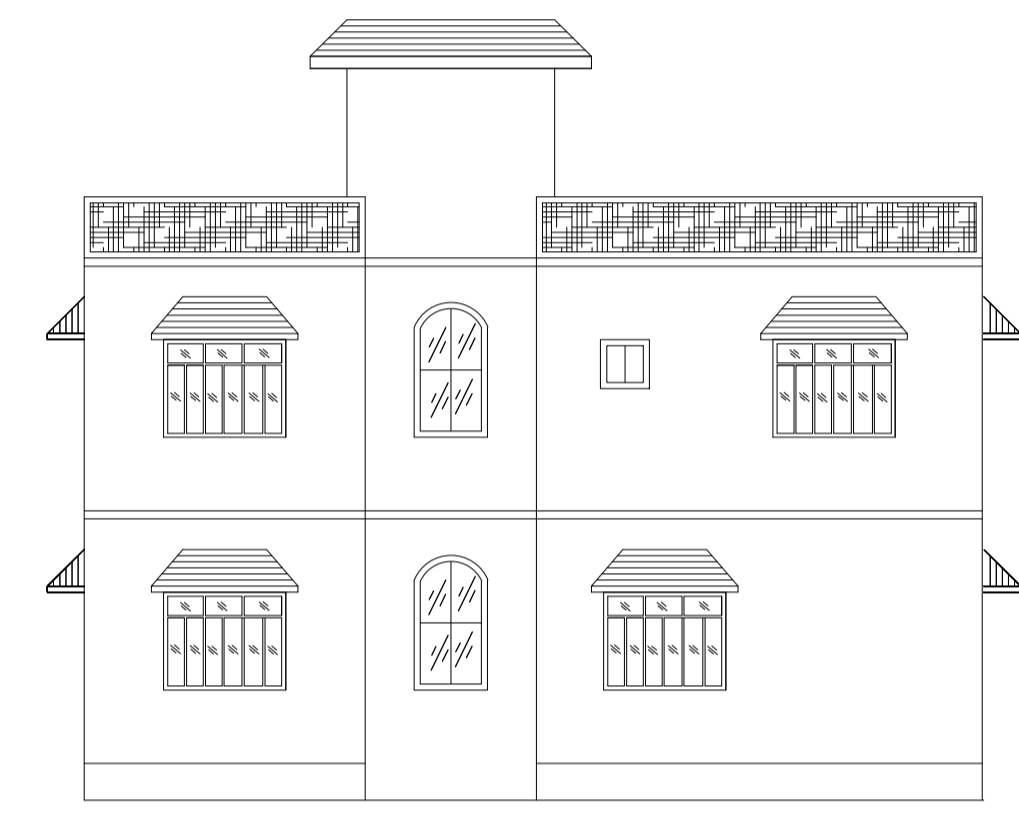
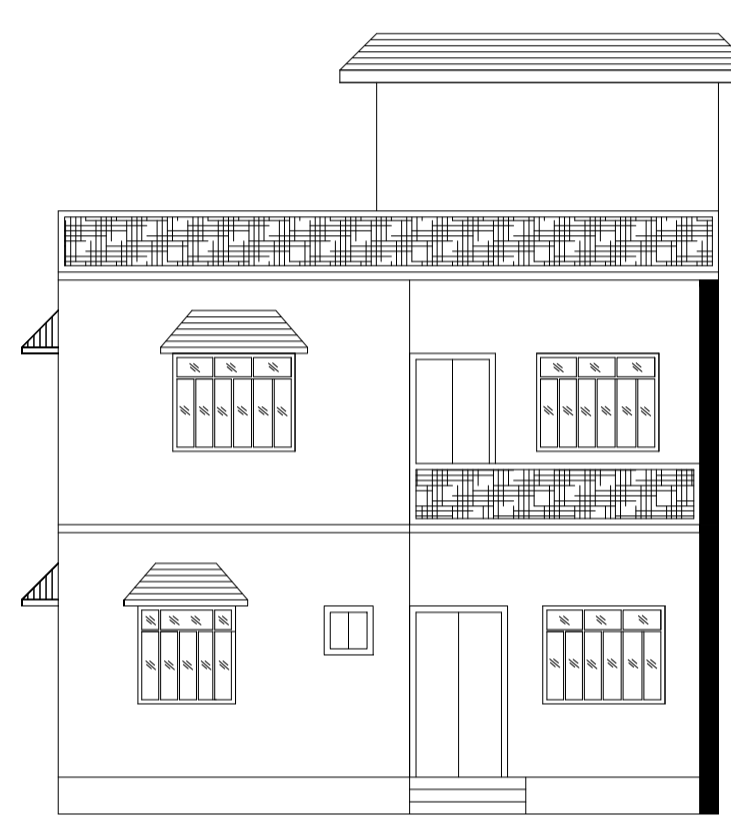
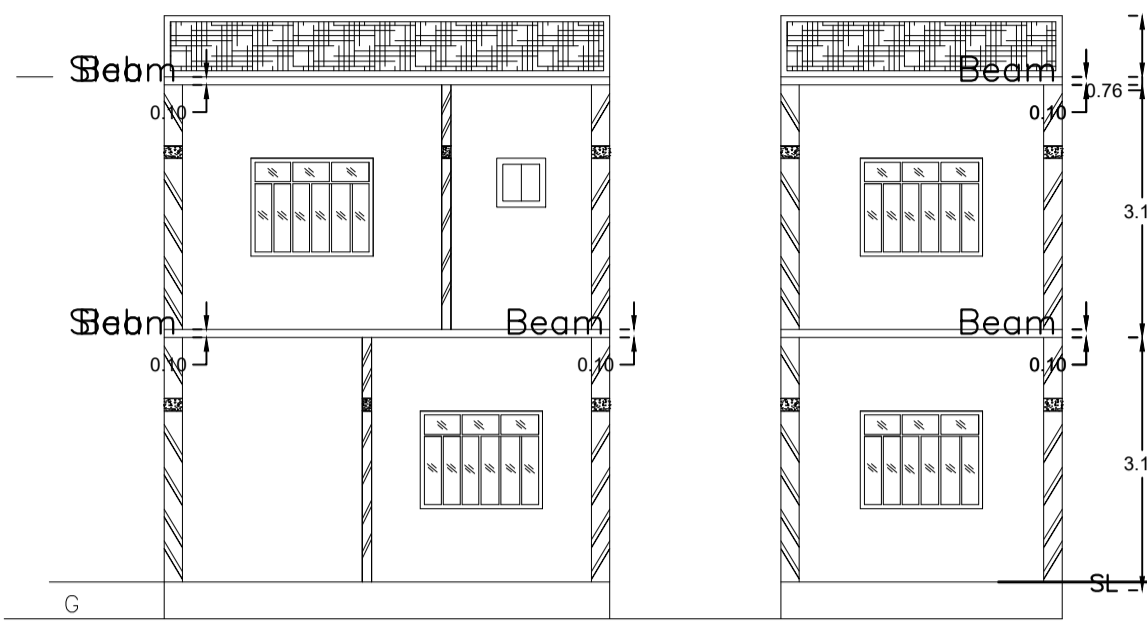
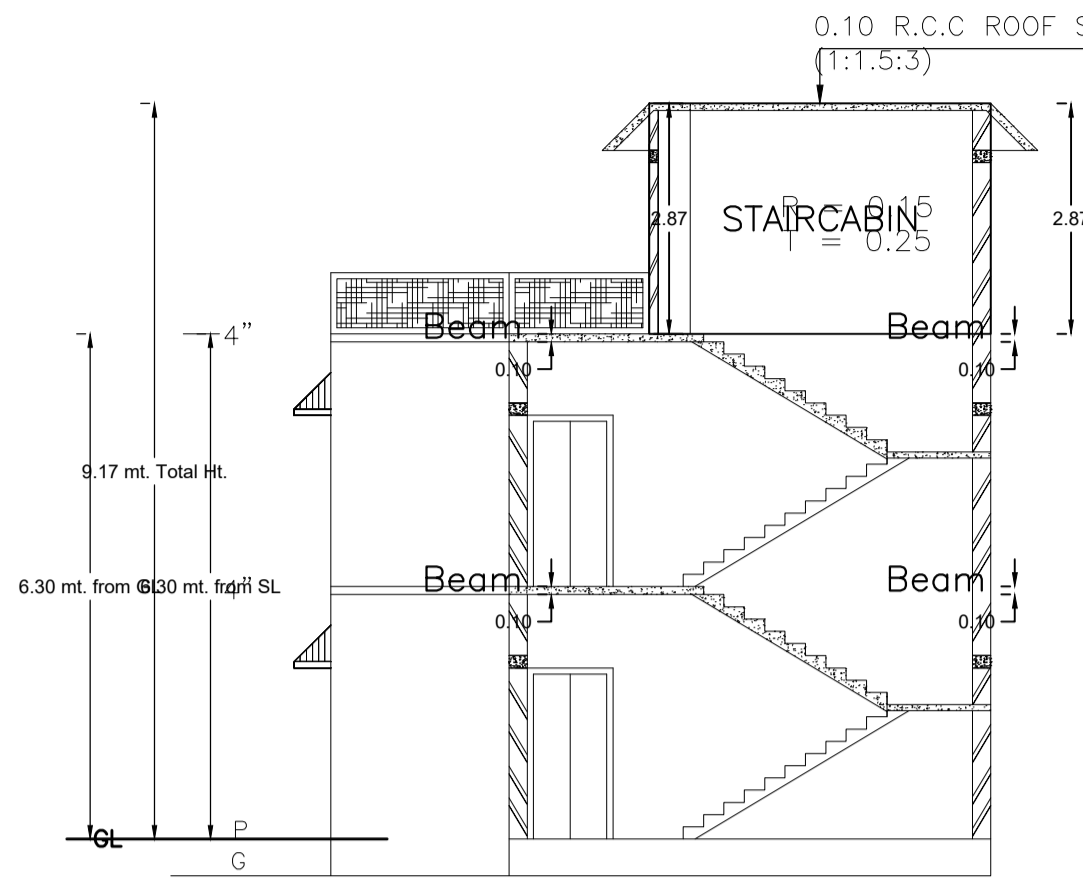
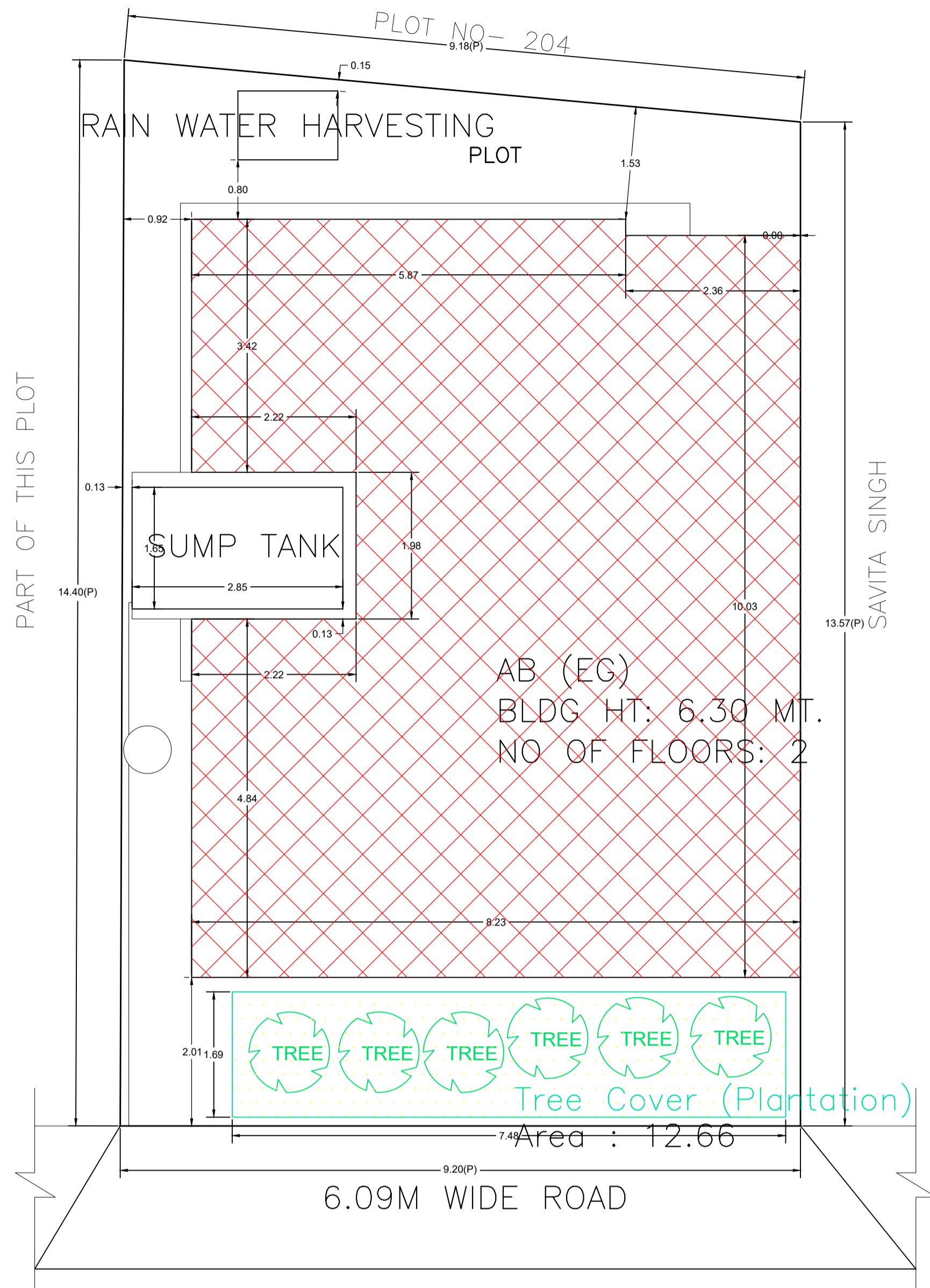

Building :AB (EG)

Floor Name	Total Built Up Area (Sq.mt.)	Proposed FAR Area (Sq.mt.) Resi.	Total FAR Area (Sq.mt.)	Total Consumed Additional FAR Area (Sq.mt.)	Tnmt (No.)
Ground Floor	79.40	79.40	79.40	79.40	01
First Floor	79.40	79.40	79.40	79.40	00
Terrace Floor	0.00	0.00	0.00	0.00	00
Total :	158.80	158.80	158.80	158.80	01

SCHEDULE OF DOOR:

BUILDING NAME	NAME	LENGTH	HEIGHT	NOS
AB (EG)	D	0.76	2.10	02
AB (EG)	D	1.03	2.10	02
AB (EG)	D	1.07	2.10	02
AB (EG)	D	1.22	2.10	01
AB (EG)	D	1.30	2.10	02

SCHEDULE OF WINDOW/VENTILATION:

BUILDING NAME	NAME	LENGTH	HEIGHT	NOS
AB (EG)	W	0.61	1.20	04
AB (EG)	W	0.91	1.20	01
AB (EG)	W	1.22	1.20	01
AB (EG)	W	1.52	1.20	09

UnitBUA Table for Building :AB (EG)

FLOOR	Name	UnitBUA Type	UnitBUA Area	Carpet Area	No. of Rooms	No. of Tenement
GROUND FLOOR PLAN	SPLIT ABC	FLAT	158.81	158.59	6	1
FIRST FLOOR PLAN	SPLIT ABC	FLAT	0.00	0.00	6	0
Total:	-	-	158.81	158.59	12	1

FAR & Tenement Details (Table 4c-1)

Building	No. of Same Bldg	Total Built Up Area (Sq.mt.)	Proposed FAR Area (Sq.mt.) Resi.	Total FAR Area (Sq.mt.)	Total Consumed Additional FAR Area (Sq.mt.)	Tnmt (No.)
AB (EG)	1	158.80	158.80	158.80	158.80	01
Grand Total:	1	158.80	158.80	158.80	158.80	01

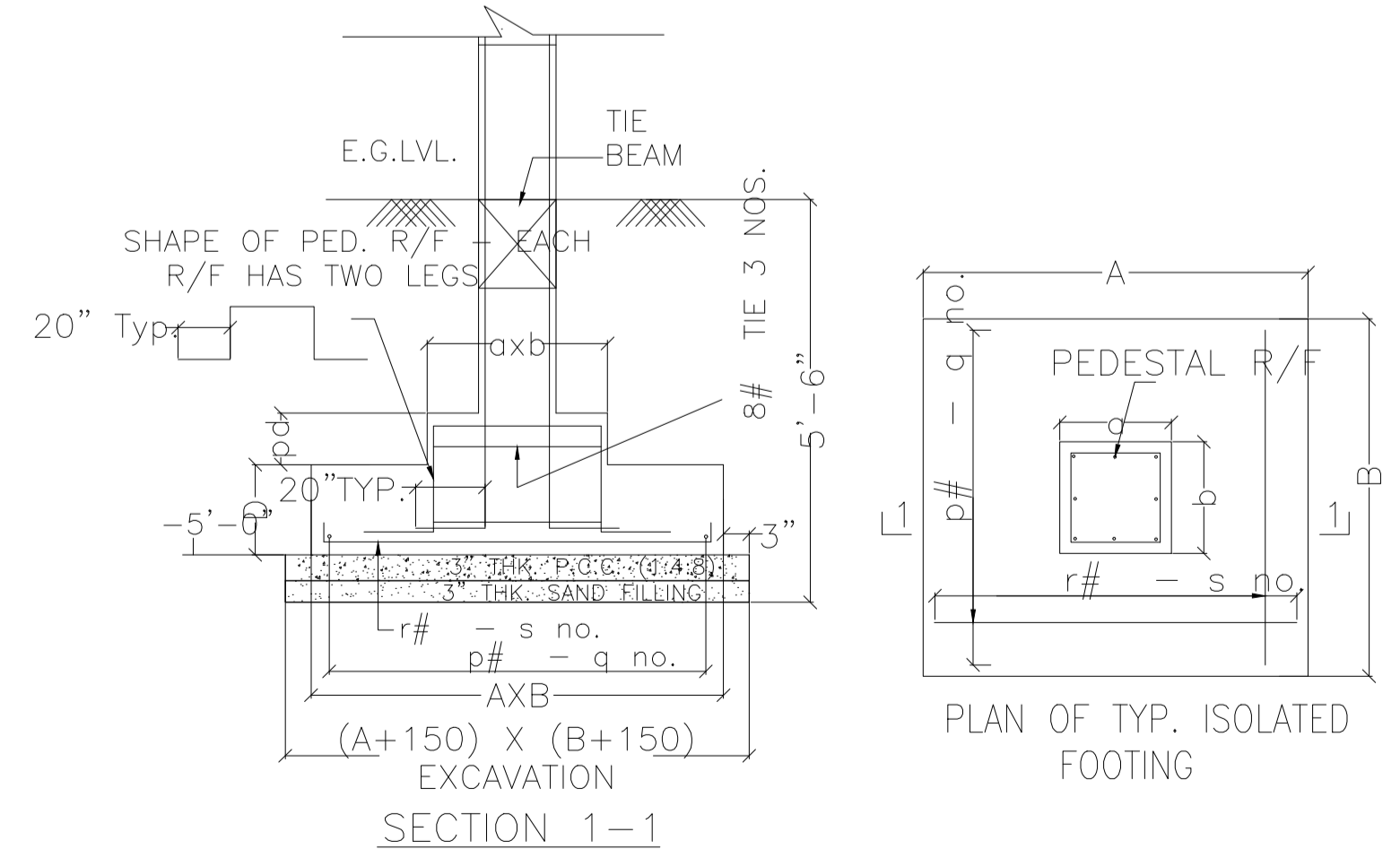
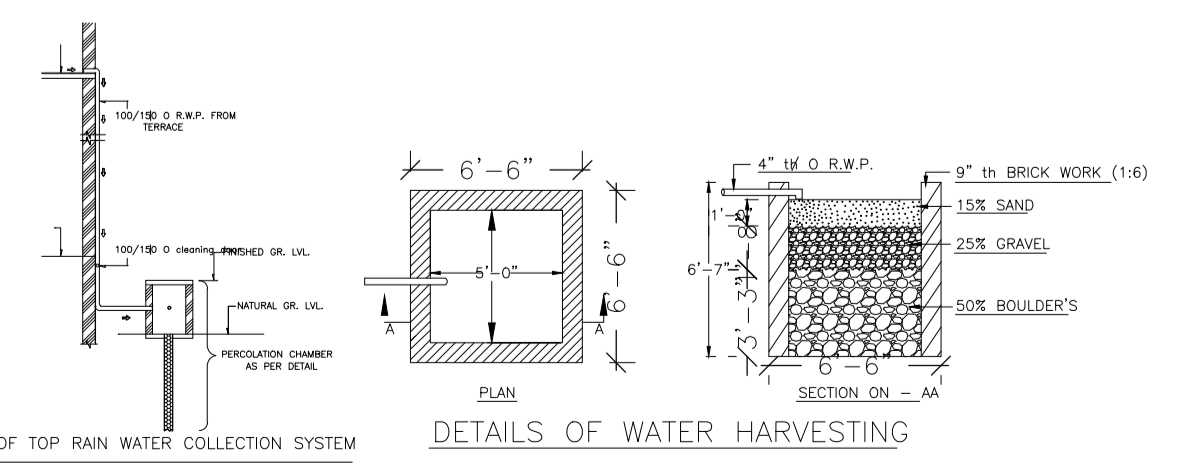
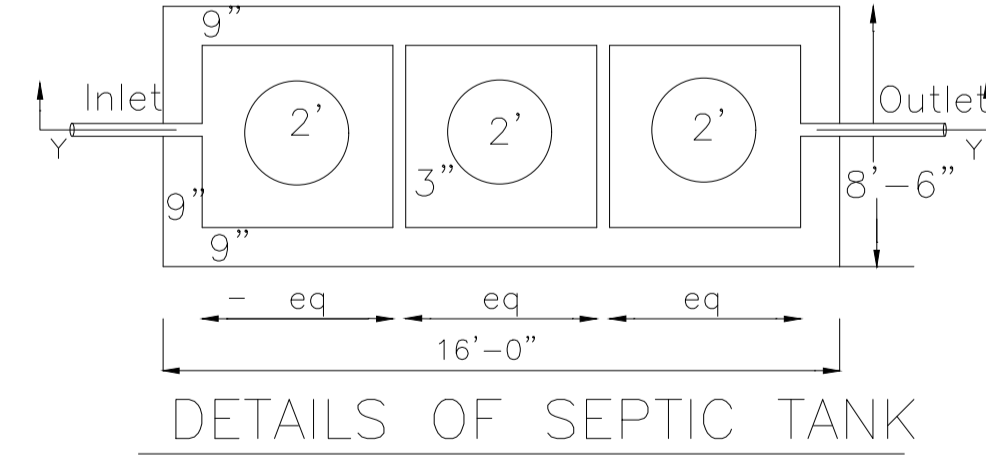
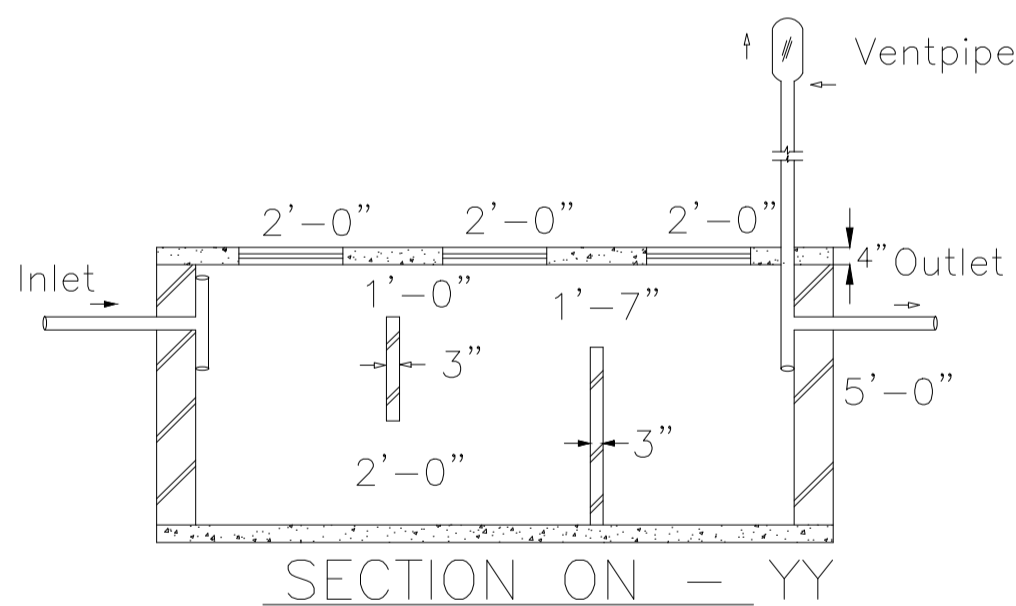

AREA STATEMENT MINERAL		VERSION NO. : 1.0.73
AREA OF PLOT (Minimum)	(A)	128.26
NET AREA OF PLOT (Gross Plot Area - Deduction from Gross Plot area)	(A-Deductions)	128.26
Deduction for Balance Plot Area (from Gross Plot Area)		
Common Plot		12.66
Total		12.66
BALANCE AREA OF PLOT (Net Plot Area - Recreational/Amenity space)	(A-Deductions)	115.60
PLOT AREA FOR COVERAGE (Net Plot Area)	(A-Deductions)	128.26
Plot Area for FAR (Net Plot Area + Road Widening Area)	(A-Deductions)	128.26
COVERAGE CHECK		
Permissible Coverage area ( 70.00 % )		89.78
Proposed Coverage Area ( 61.91 % )		79.40
Total Prop. Coverage Area ( 61.91 % )		79.40
Balance coverage area ( 8.09 % )		10.38
FAR CHECK		
Perm. FAR Area ( 1.800 )		230.87
Total Perm. FAR area		230.87
Residential FAR		158.81
Proposed FAR Area		158.81
Total Proposed FAR Area		158.81
Consumed FAR (Factor)		1.24
Balance FAR Area		72.06
BUILT UP AREA CHECK		
Total Proposed BuiltUp Area		158.80
ARCHITECT (Regd)	ABHISHEK KUMAR	
ENGINEER (Regd)		
SUPERVISOR (Regd)		
OWNER (Regd)	SRI SANJAY KUMAR SINGH	
DEVELOPMENT AUTHORITY		LOCAL BODY

COLOR INDEX

PLOT BOUNDARY	Black
ABUTTING ROAD	Red
PROPOSED CONSTRUCTION	Green
COMMON PLOT	Yellow
ROAD WIDENING AREA	Blue
EXISTING (To be retained)	Grey
EXISTING (To be demolished)	White

Buildingwise Floor FAR Details

Floor Name	Building Name		Total	
	Proposed Built Up Area (Sq.mt.)	Proposed FAR Area (Sq.mt.)	Total Proposed Built Up Area (Sq.mt.)	Total FAR Area (Sq.mt.)
Ground Floor	79.40	79.40	79.40	79.40
First Floor	79.40	79.40	79.40	79.40
Terrace Floor	0.00	0.00	0.00	0.00
Total :	158.80	158.80	158.80	158.80

Building USE/SUBUSE Details

Building Name	Building Use	Building SubUse	Building Structure	Floor Name	Floor Use	Floor SubUse	FAR Name	FAR Use	FAR SubUse
AB (EG)	Residential	Bungalow/ Dwelling / Non Apartment	Non-Highrise	GROUND FLOOR PLAN	Residential	Bungalow/ Dwelling / Non Apartment	Residential FAR	Residential	Bungalow/ Dwelling / Non Apartment
				FIRST FLOOR PLAN	Residential	Bungalow/ Dwelling / Non Apartment	Residential FAR	Residential	Bungalow/ Dwelling / Non Apartment
				TERRACE FLOOR PLAN	Residential	Bungalow/ Dwelling / Non Apartment	-	-	-

LTP NAME AND SIGNATURE	STRUCTURAL ENG'S NAME AND SIGNATURE	BUILDER NAME AND SIGNATURE	DIGITAL SIGNATURE
ABHISHEK KUMAR MADA/DTMN/0014/2020			

Proposal Basic Information	
Proposal File No.	MADA/BP/0264/2024
Owner Name	SRI SANJAY KUMAR SINGH
Khata No	NEW - 98, OLD - 12
Plot No	NEW - 223, OLD - 136
Village Name	Gosaidih
Use	Residential
SubUse	Bungalow/ Dwelling / Non Apartment

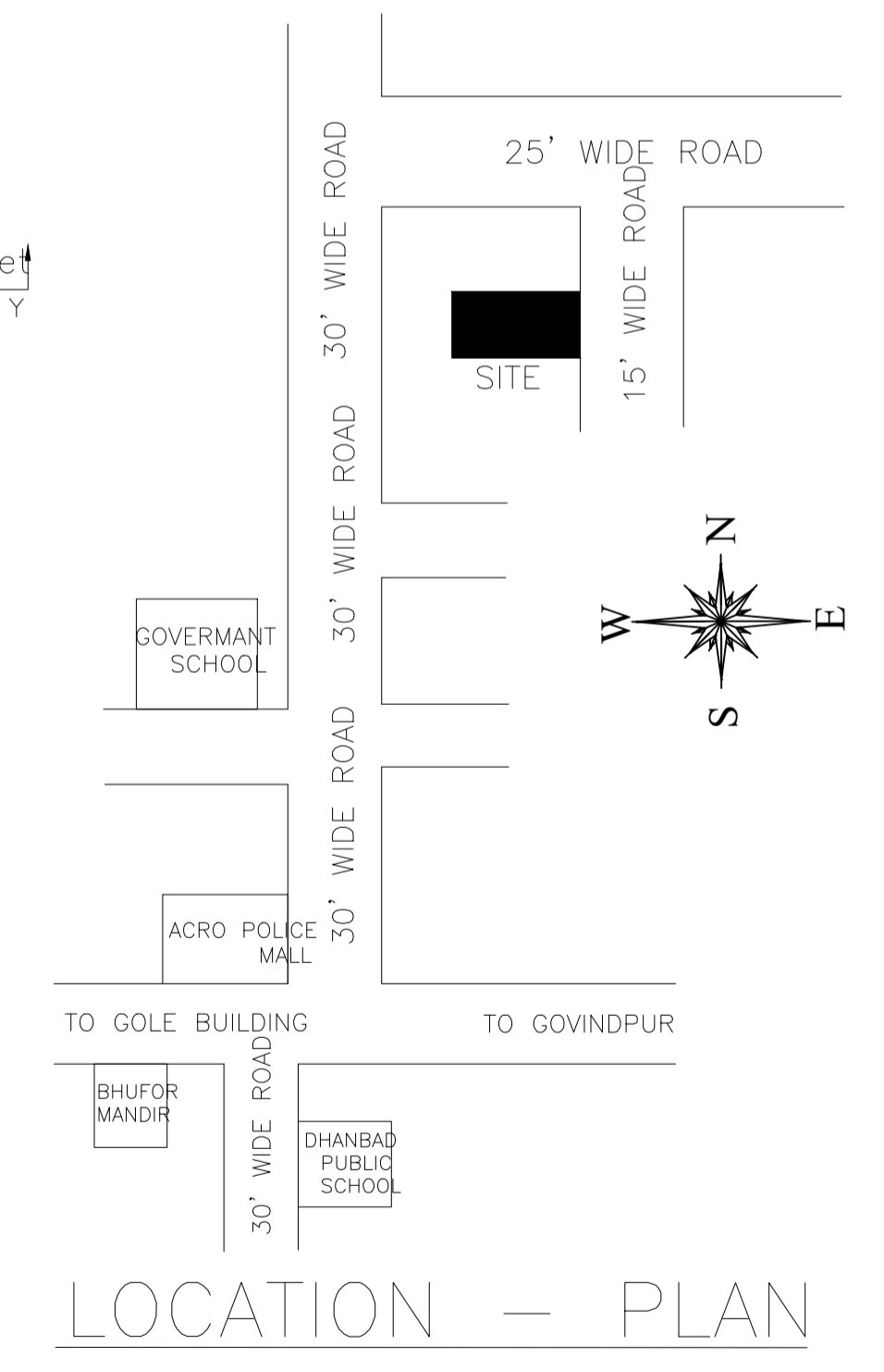
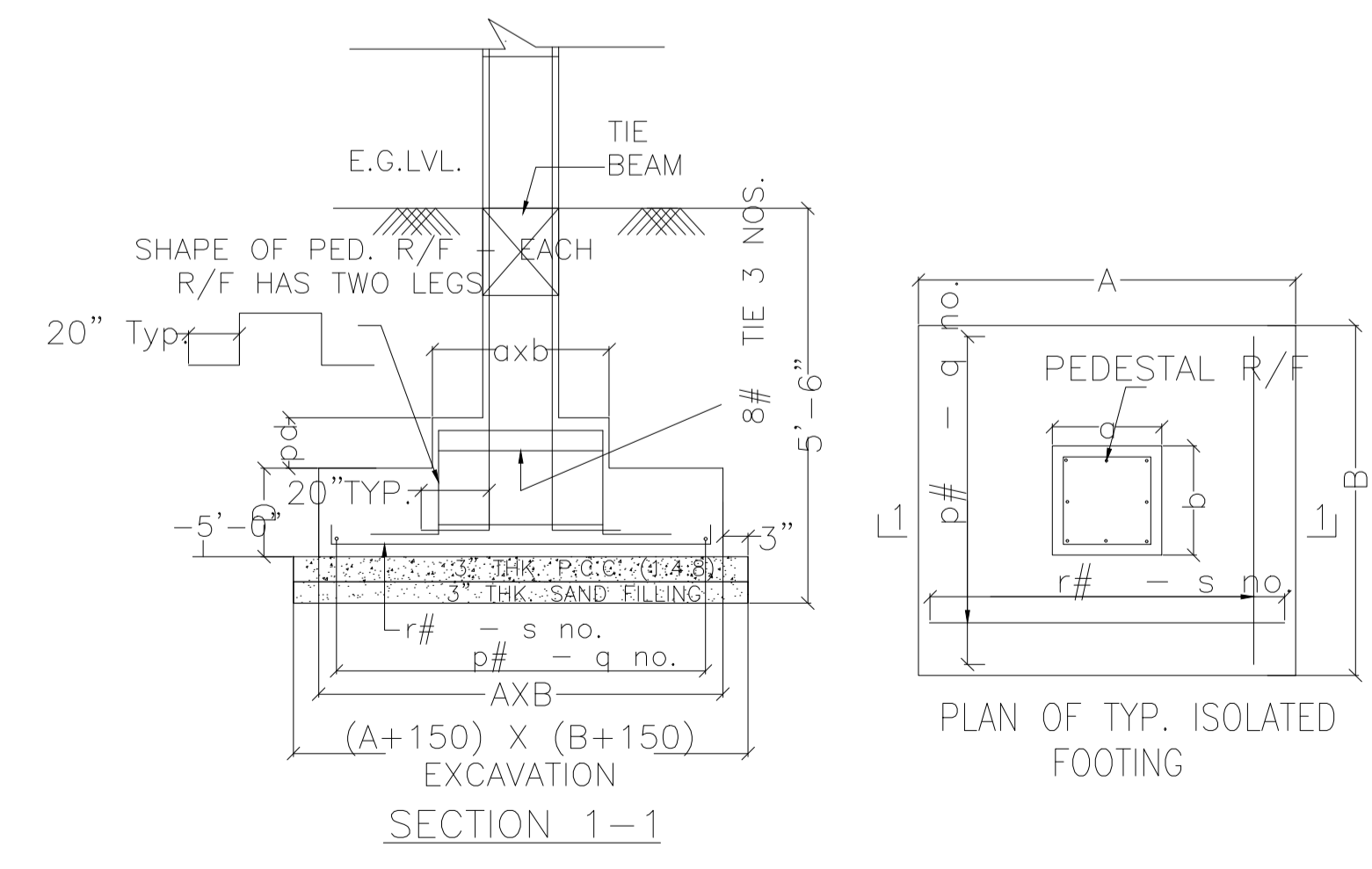
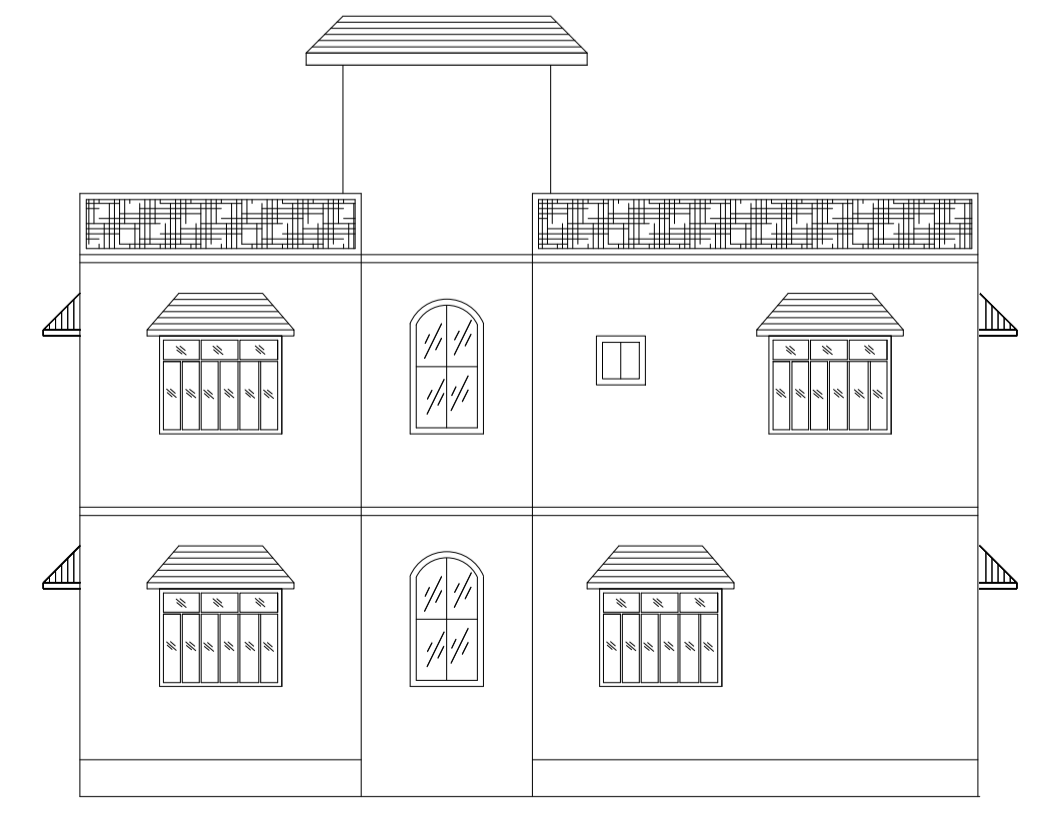
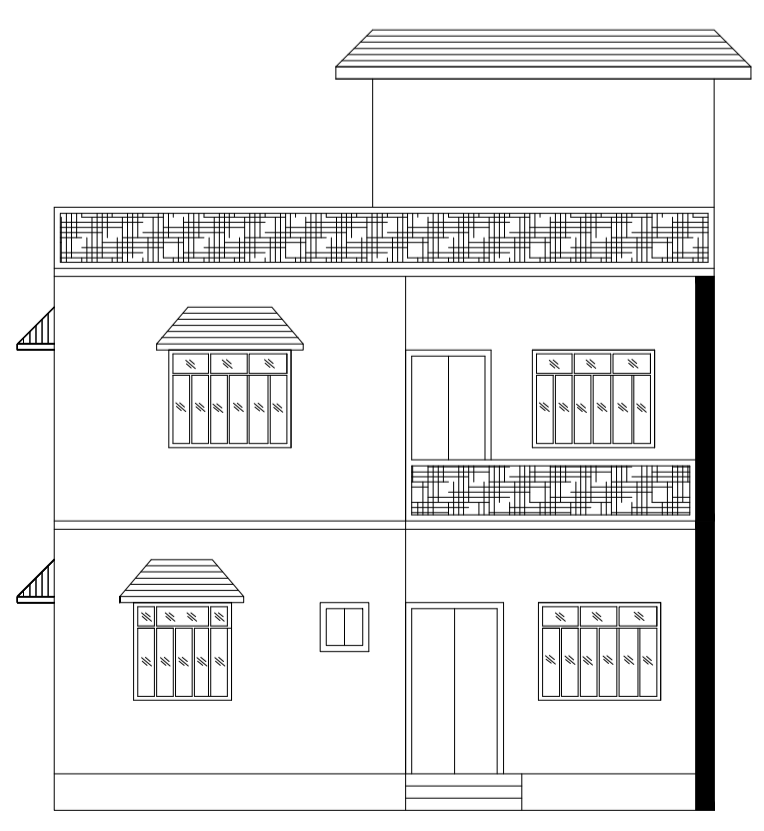
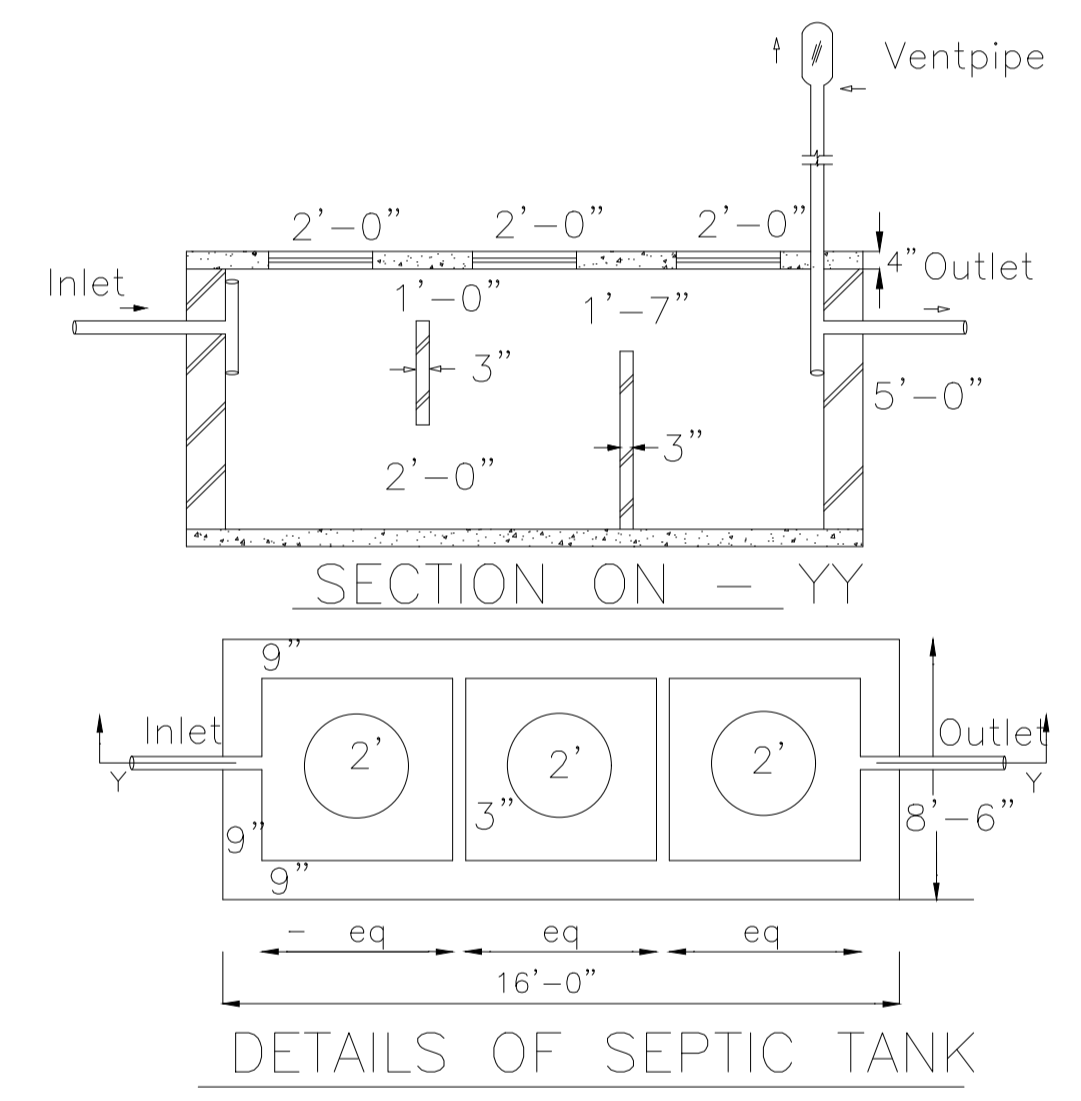
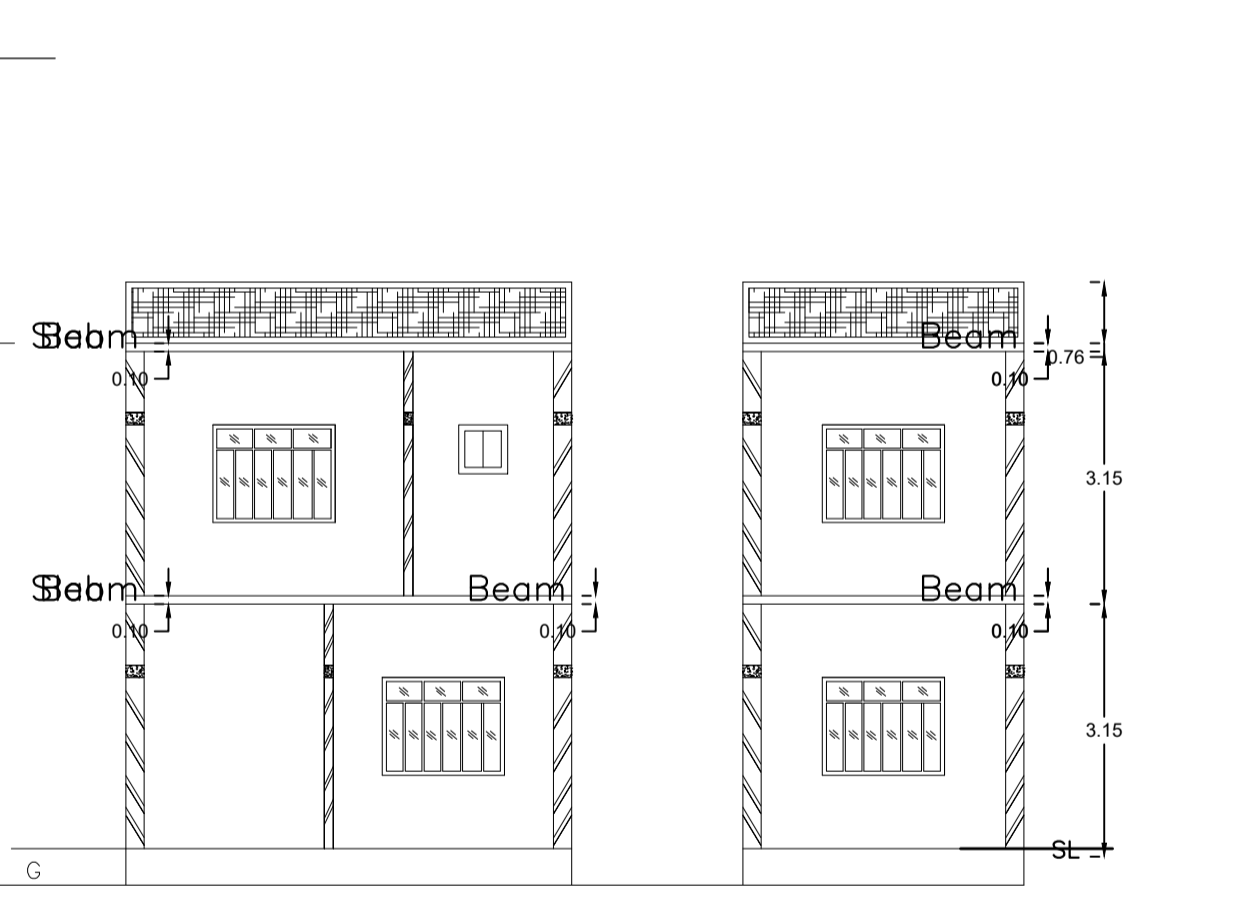
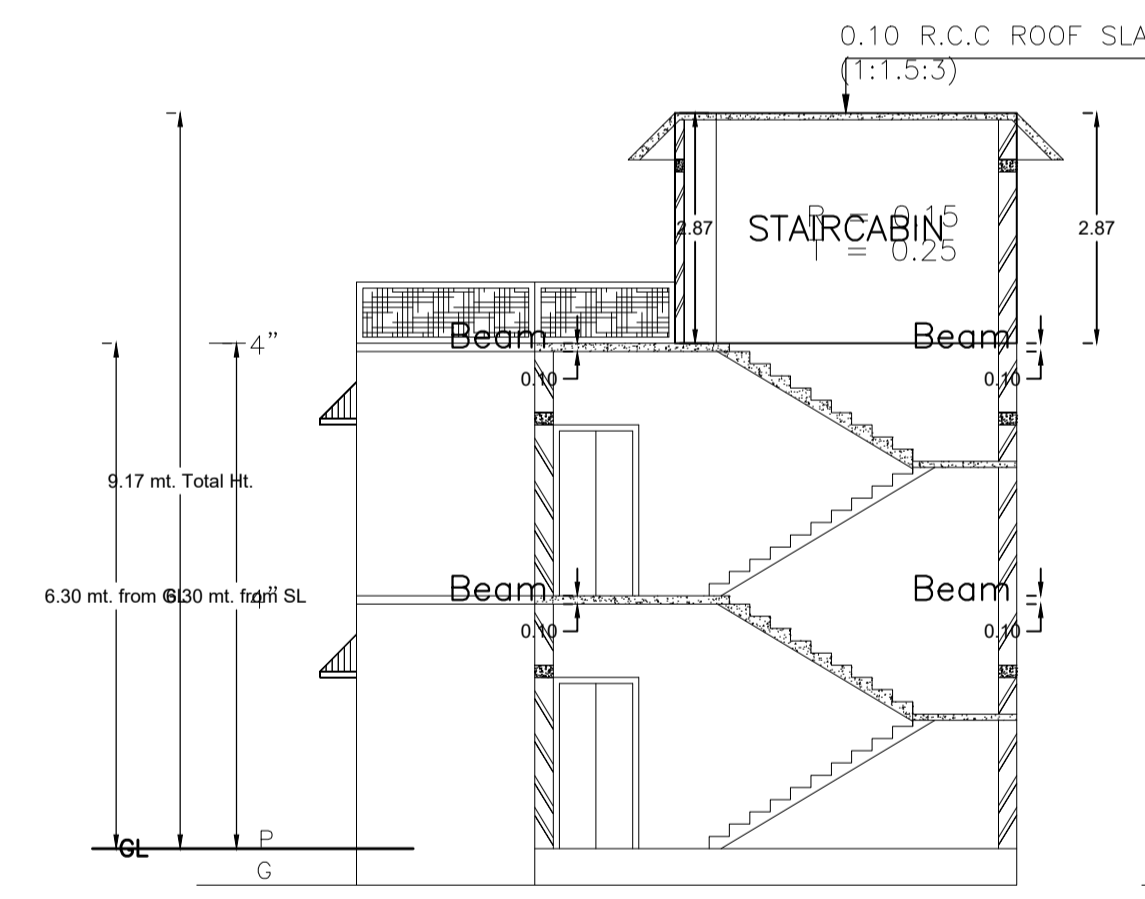
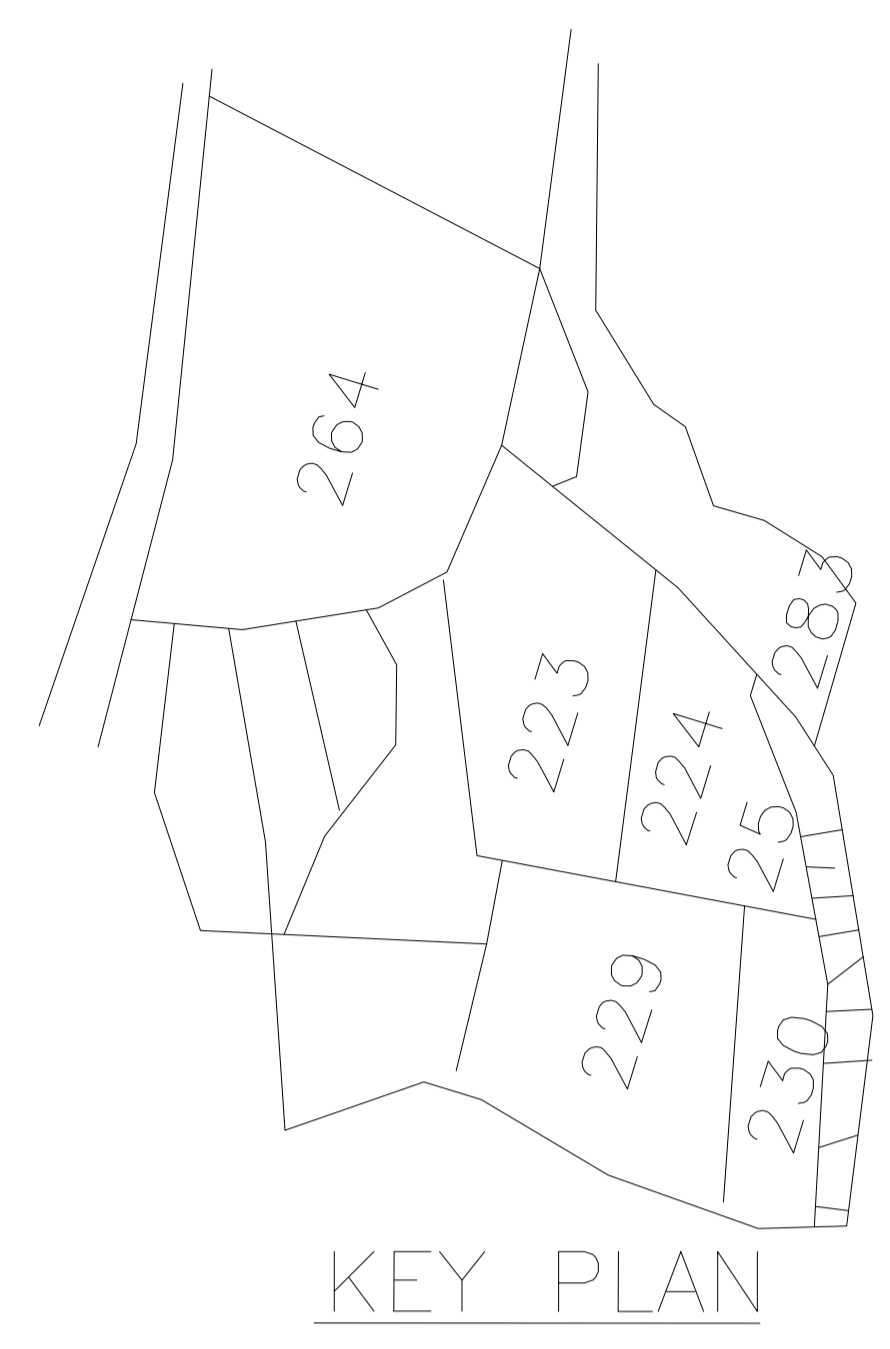
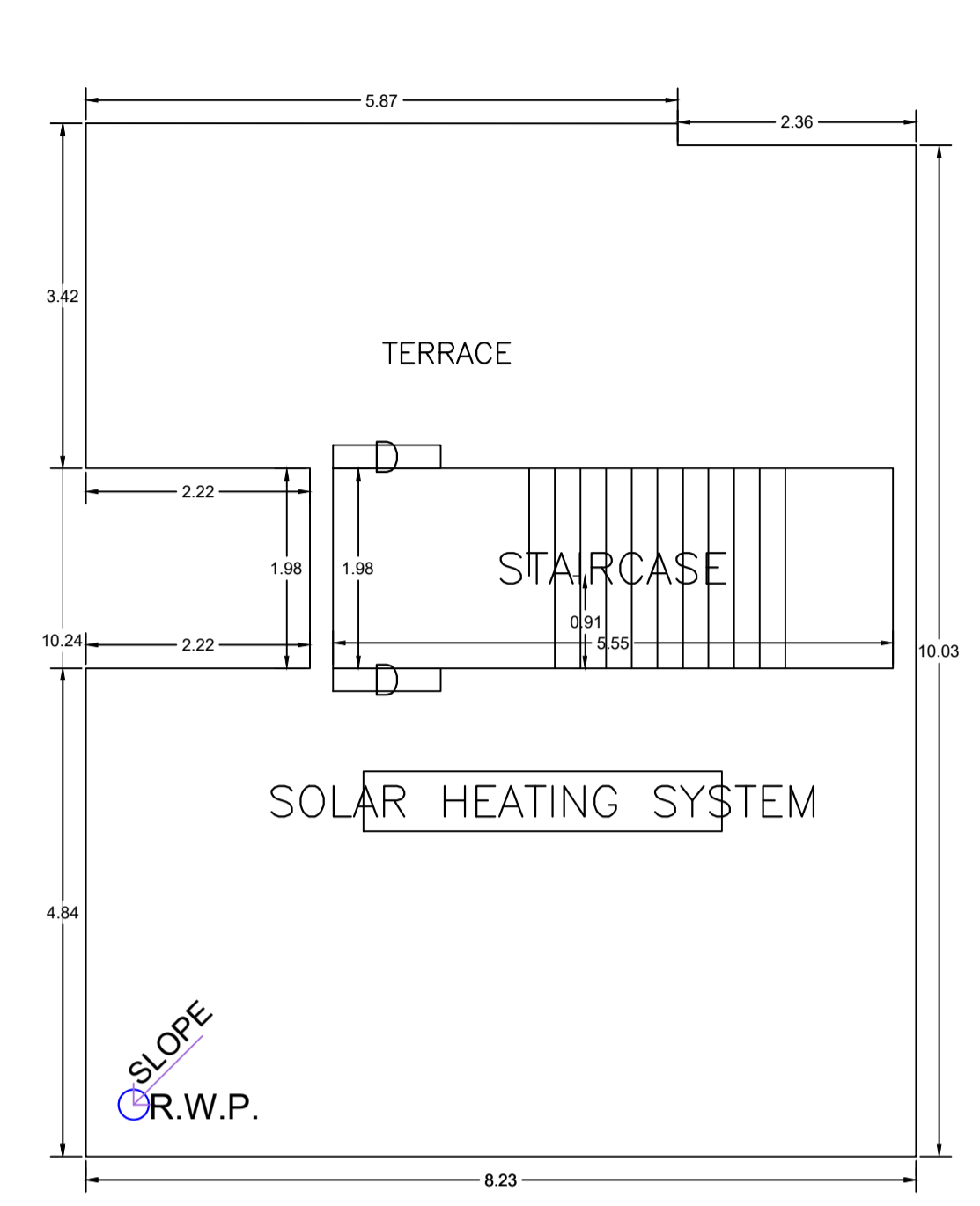
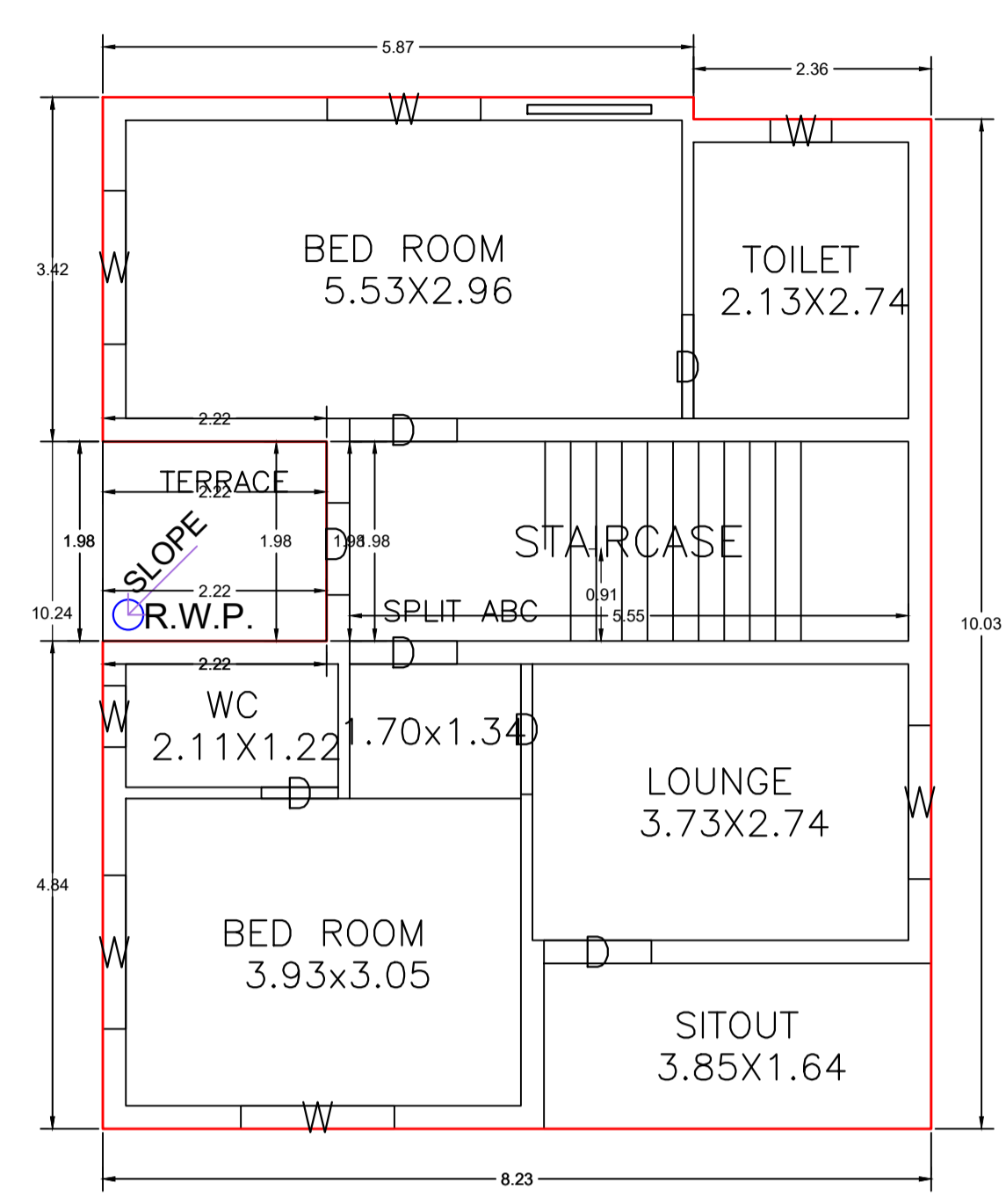
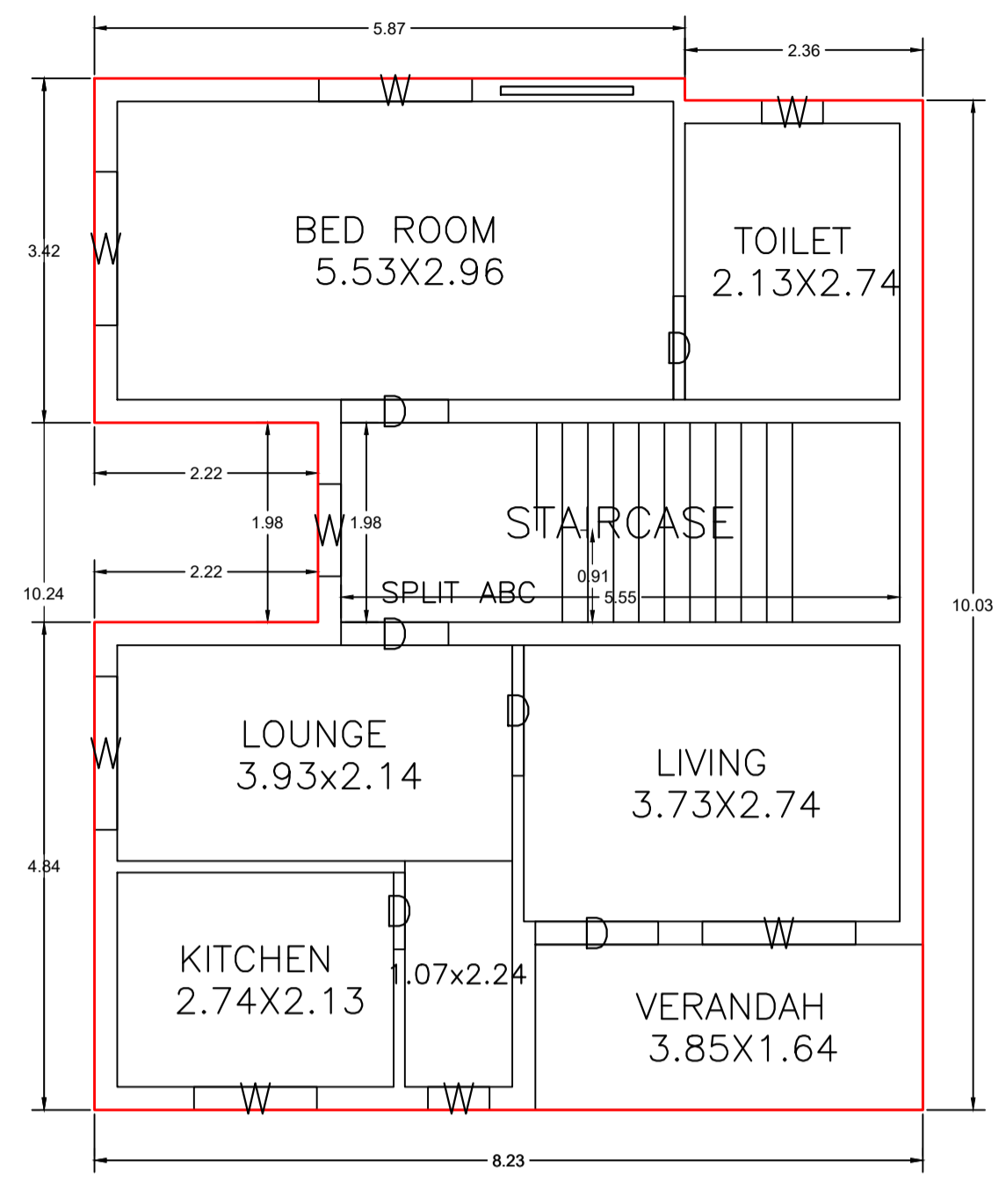

LTP NAME AND SIGNATURE	STRUCTURAL ENG'S NAME AND SIGNATURE	BUILDER NAME AND SIGNATURE	DIGITAL SIGNATURE
ABHISHEK KUMAR MADA/DTMN/0014/2020			