

UnitBUA Table for Building :A (MALTI)

FLOOR	Name	UnitBUA Type	UnitBUA Area	Carpet Area	No. of Rooms	No. of Tenement
GROUND FLOOR PLAN	SPLIT A	FLAT	185.65	185.50	8	1
FIRST FLOOR PLAN	SPLIT A	FLAT	0.00	0.00	8	0
Total:	-	-	185.65	185.50	16	1

SCHEDULE OF DOOR:

BUILDING NAME	NAME	LENGTH	HEIGHT	NOS
A (MALTI)	D	0.84	2.10	04
A (MALTI)	D	0.91	2.10	04
A (MALTI)	D	1.07	2.10	08
A (MALTI)	D	1.23	2.10	01

SCHEDULE OF WINDOW/VENTILATION:

BUILDING NAME	NAME	LENGTH	HEIGHT	NOS
A (MALTI)	V	0.61	1.20	04
A (MALTI)	W	0.91	1.20	04
A (MALTI)	W	1.22	1.20	12
A (MALTI)	W	2.12	1.20	01
A (MALTI)	W	2.82	1.20	01

Building :A (MALTI)

Floor Name	Total Built Up Area (Sq.mt.)	Proposed FAR Area (Sq.mt.) Resi.	Total FAR Area (Sq.mt.)	Total Consumed Additional FAR Area (Sq.mt.)	Tnmt (No.)
Ground Floor	92.82	92.82	92.82	92.82	01
First Floor	92.82	92.82	92.82	92.82	00
Terrace Floor	0.00	0.00	0.00	0.00	00
Total :	185.64	185.64	185.64	185.64	01

FAR & Tenement Details

Building	No. of Same Bldg	Total Built Up Area (Sq.mt.)	Proposed FAR Area (Sq.mt.) Resi.	Total FAR Area (Sq.mt.)	Total Consumed Additional FAR Area (Sq.mt.)	Tnmt (No.)
A (MALTI)	1	185.64	185.64	185.64	185.64	01
Grand Total :	1	185.64	185.64	185.64	185.64	01

Proposal Basic Information

Proposal File No.	MADA/BP/0288/2024
Owner Name	SMT MALTI DEVI
Khata No	OLD KHATA NO-55 & 55, NEW KHATA NO-196 & 92
Plot No	OLD PLOT NO-1313, 1313 & 1310, NEW PLOT NO-1361, 1361 & 1360
Village Name	Kurmidih
Use	Residential
SubUse	Bungalow/ Dwelling / Non Apartment

AREA STATEMENT MINERAL AREA DEVELOPMENT AUTHORITY

VERSION NO.: 1.0.74
VERSION DATE: 16/10/2020

PROJECT DETAIL:
Region: JHARKHAND URBAN LOCAL BODIES
District: DHANBAD
Authority: MINERAL AREA DEVELOPMENT AUTHORITY
Plot Use: Residential
Plot SubUse: Bungalow/ Dwelling / Non Apartment
PlotNearby/ReligiousStructure: NA

Inward_No: MADA/BP/0288/2024
Plot/SubPlot No: OLD PLOT NO-1313, 1313 & 1310, NEW PLOT NO-1361, 1361 & 1360

Application Type: General Proposal
North: Plot No. - SAME PLOT
Project Type: Building Permission
South: Plot No. - SAME PLOT
Nature of Development: New
East: Plot No. - SAME PLOT
Location of Development Area: Old Area
West: Road Width - 6.10

AREA DETAILS:
AREA OF PLOT (Minimum) (A) 157.71
NET AREA OF PLOT(Gross Plot Area - Deduction from Gross Plot area) (A-Deductions) 157.71
Deduction for Balance Plot Area(from Gross Plot Area)
Common Plot 18.79
Total 18.79
BALANCE AREA OF PLOT(Net Plot Area - Recreational/Amenity space) (A-Deductions) 138.92
PLOT AREA FOR COVERAGE(Net Plot Area) (A-Deductions) 157.71
Plot Area for FAR (Net Plot Area + Road/Widening Area) (A-Deductions) 157.71

COVERAGE CHECK
Permissible Coverage area (70.00 %) 110.40
Proposed Coverage Area (58.86 %) 92.82
Total Prop. Coverage area (58.86 %) 92.82
Balance coverage area (11.15 %) 17.58

FAR CHECK
Perm. FAR Area (2.500) 394.28
Total Perm. FAR area 394.28
Residential FAR 185.65
Proposed FAR Area 185.65
Total Proposed FAR Area 185.65
Consumed FAR (Factor) 1.18
Balance FAR Area 208.63

BUILT UP AREA CHECK
Total Proposed BuiltUp Area 185.64

ARCHITECT (Regd) RAM PRATAP SINGH
ENGINEER (Regd)
SUPERVISOR (Regd)
OWNER (Regd) SMT MALTI DEVI

DEVELOPMENT AUTHORITY LOCAL BODY

COLOR INDEX

PLOT BOUNDARY	Black
ABUTTING ROAD	Green
PROPOSED CONSTRUCTION	Red
COMMON PLOT	Yellow
ROAD WIDENING AREA	Blue
EXISTING (To be retained)	Orange
EXISTING (To be demolished)	Light Blue

Buildingwise Floor FAR Details

Floor Name	A (MALTI)		Total	
	Proposed Built Up Area (Sq.mt.)	Proposed FAR Area (Sq.mt.)	Total Proposed Built Up Area (Sq.mt.)	Total FAR Area (Sq.mt.)
Ground Floor	92.82	92.82	92.82	92.82
First Floor	92.82	92.82	92.82	92.82
Terrace Floor	0.00	0.00	0.00	0.00
Total :	185.64	185.64	185.64	185.64

Building USE/SUBUSE Details

Building Name	Building Use	Building SubUse	Building Structure	Floor Name	Floor Use	Floor SubUse	FAR Name	FAR Use	FAR SubUse
A (MALTI)	Residential	Bungalow/ Dwelling / Non Apartment	Non-Highrise	GROUND FLOOR PLAN	Residential	Bungalow/ Dwelling / Non Apartment	Residential FAR	Residential	Bungalow/ Dwelling / Non Apartment
				FIRST FLOOR PLAN	Residential	Bungalow/ Dwelling / Non Apartment	Residential FAR	Residential	Bungalow/ Dwelling / Non Apartment
				TERRACE FLOOR PLAN	Residential	Bungalow/ Dwelling / Non Apartment	-	-	-

LTP NAME AND SIGNATURE RAM PRATAP SINGH MADA/ARC/0024/2019	STRUCTURAL ENG'S NAME AND SIGNATURE	BUILDER NAME AND SIGNATURE	DIGITAL SIGNATURE
--	-------------------------------------	----------------------------	-------------------

Proposal Basic Information	
Proposal File No.	MADA/BP/0288/2024
Owner Name	SMT MALTI DEVI
Khata No	OLD KHATA NO-55 & 55, NEW KHATA NO-196 & 92
Plot No	OLD PLOT NO-1313, 1313 & 1310, NEW PLOT NO-1361, 1361 & 1360
Village Name	Kurmidih
Use	Residential
SubUse	Bungalow/ Dwelling / Non Apartment

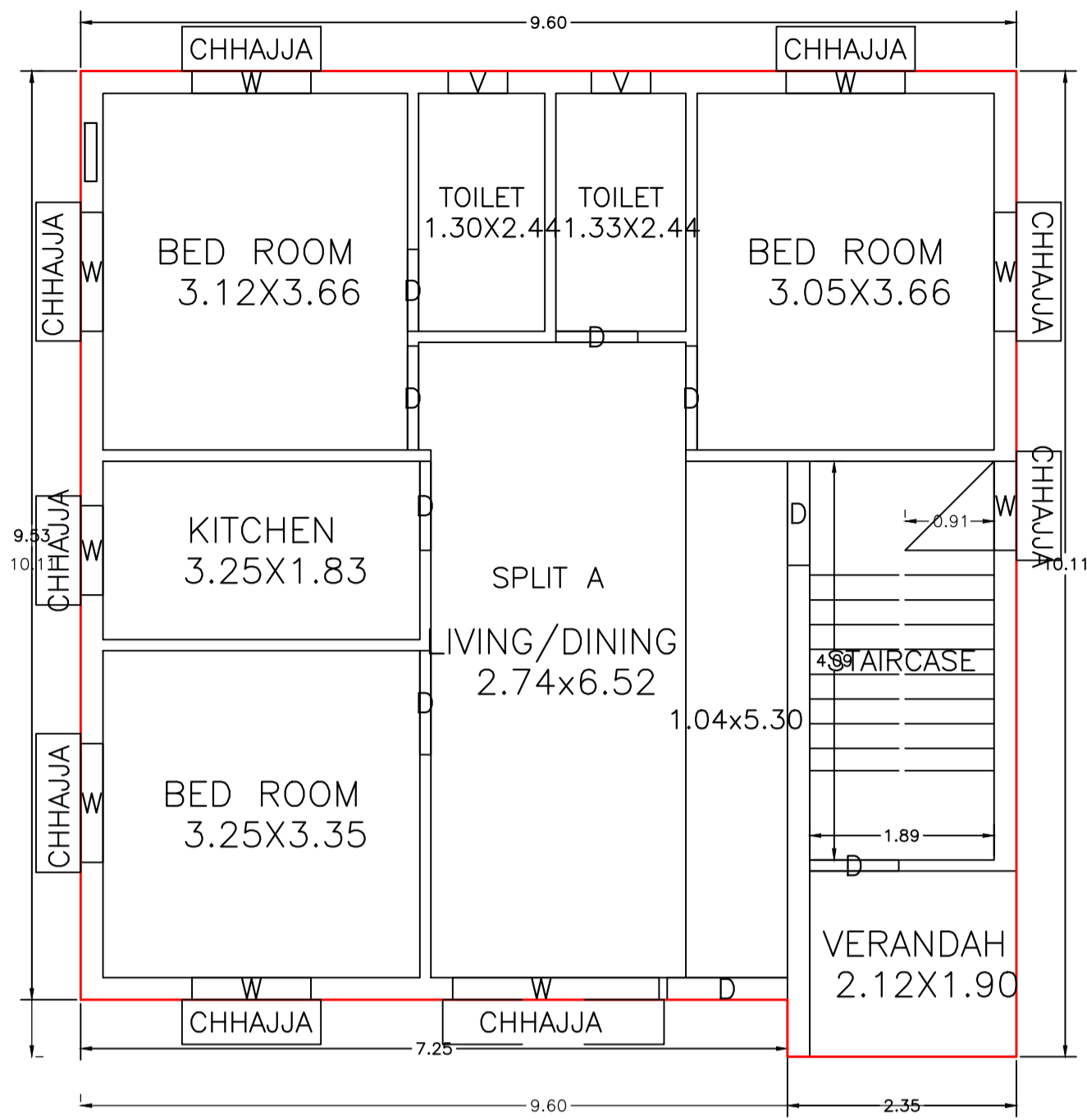

GROUND FLOOR PLAN
(Proposed)
(SCALE 1:100)

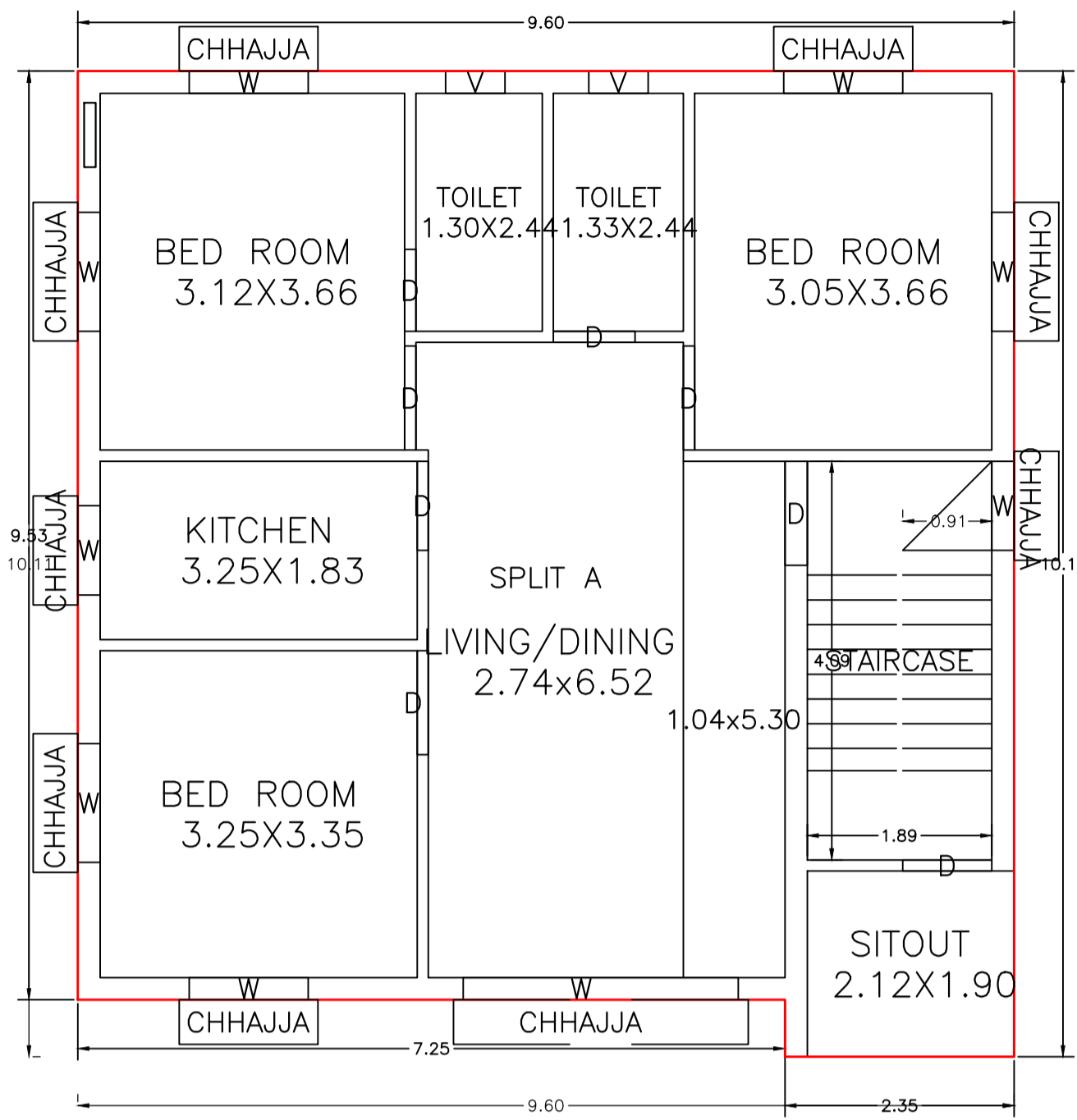

FIRST FLOOR PLAN
(Proposed)
(SCALE 1:100)

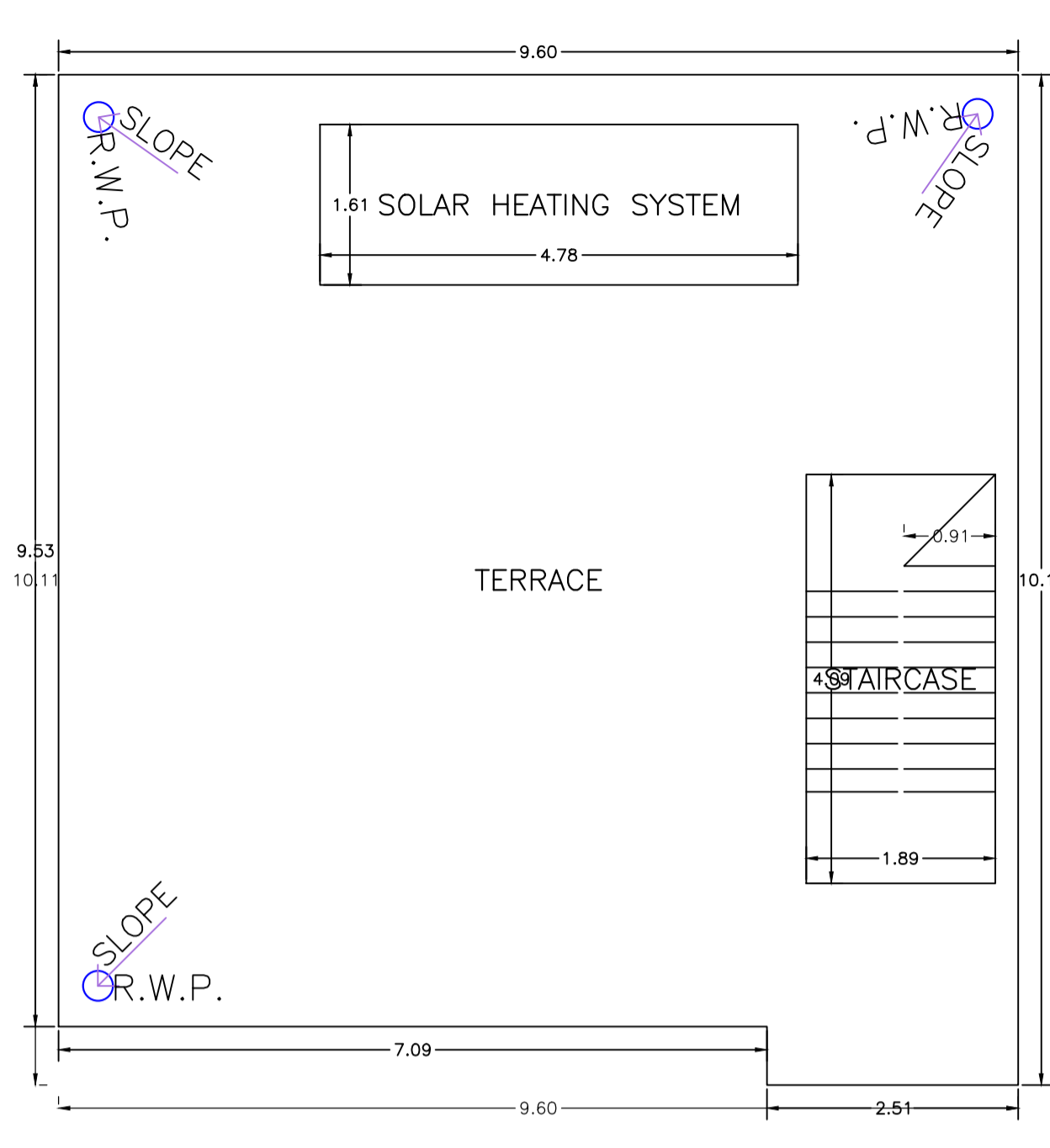

TERRACE FLOOR PLAN
(SCALE 1:100)

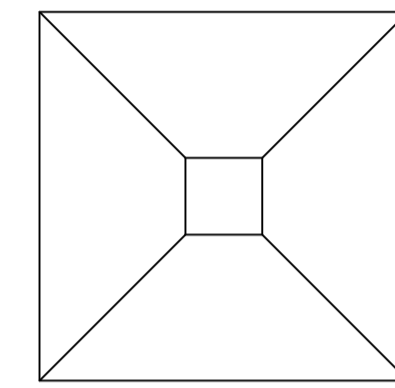
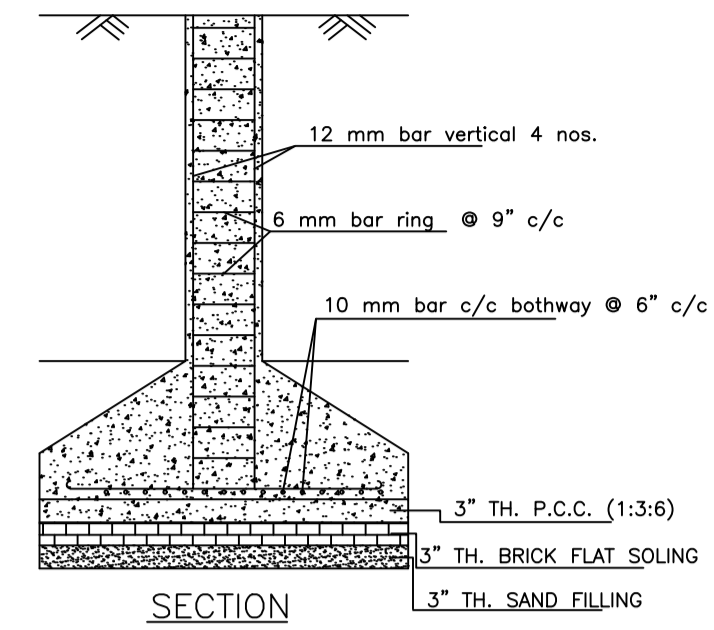

DETAILS OF COLUMN FOUNDATION
SCALE - 1" = 2'-0"

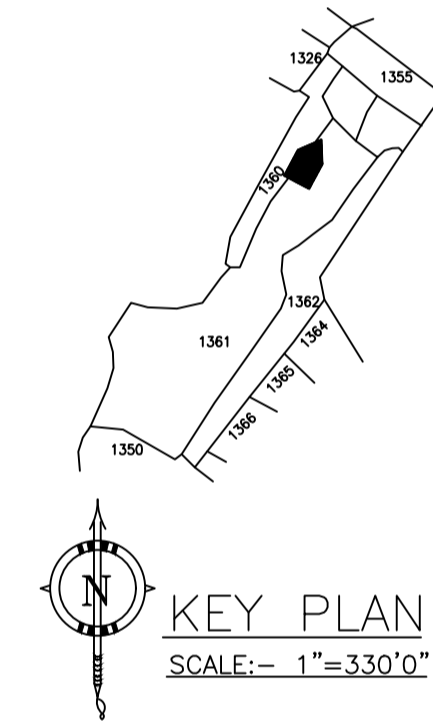

KEY PLAN
SCALE:- 1"=330'0"

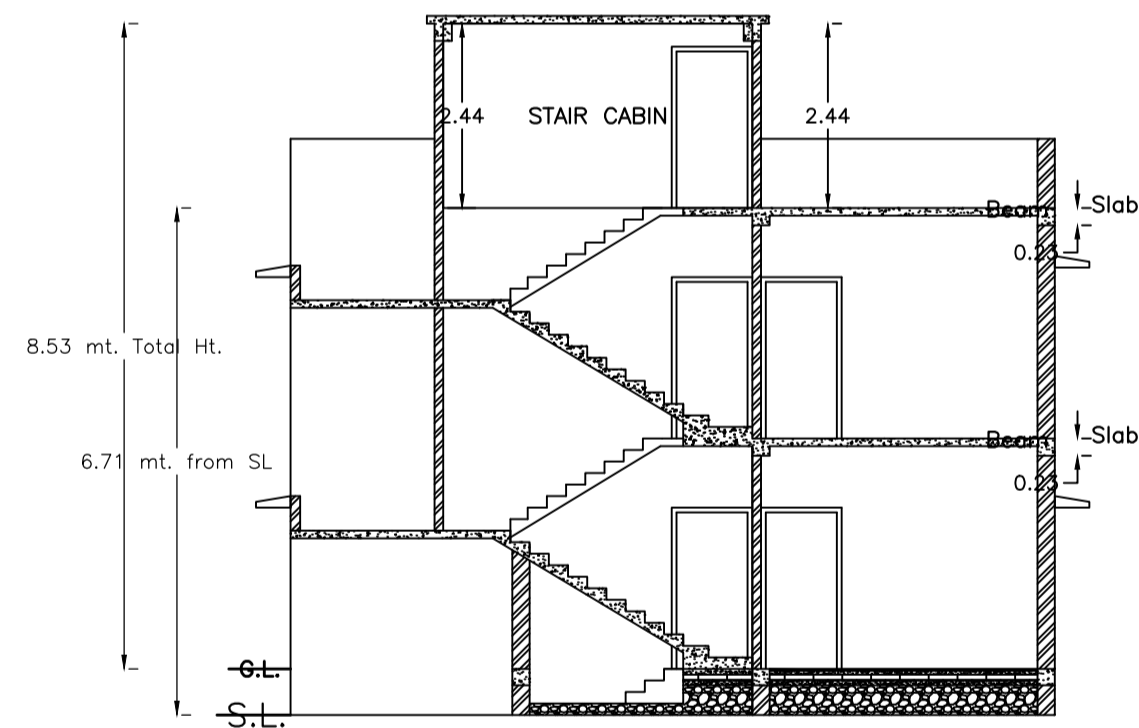

SECTION - XX'
SCALE - 1" = 8'-0"

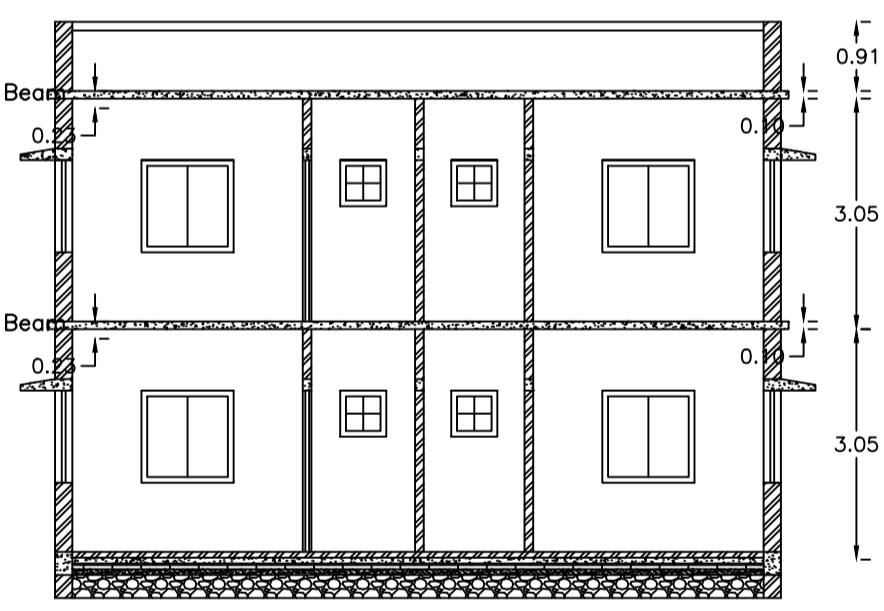

SECTION - YY'
SCALE - 1" = 8'-0"

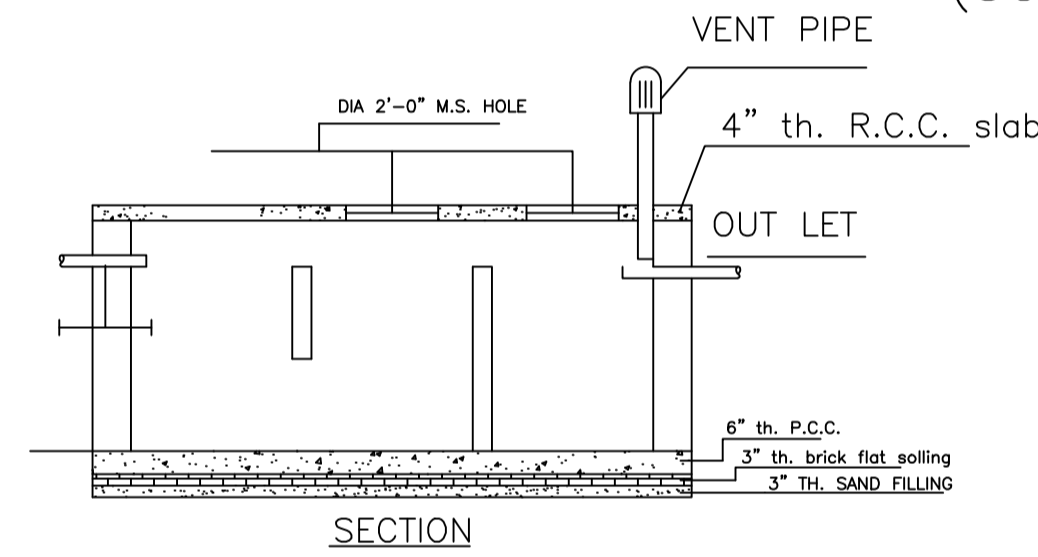

DETAILS OF SEPTIC TANK
SCALE - 1" = 4'-0"

ROOF TOP RAIN WATER COLLECTION SYSTEM

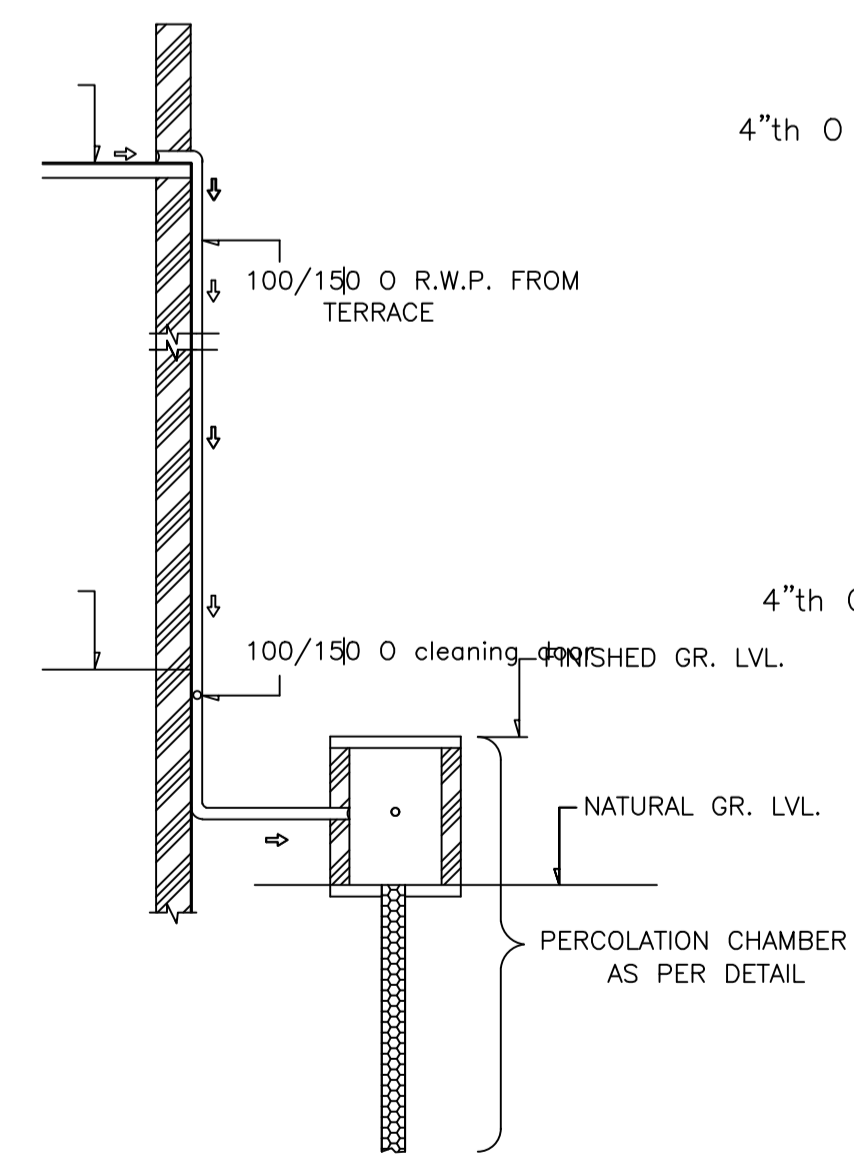

SECTION OF SOAK PIT

DETAILS OF SOAK PIT
SCALE = 1" = 2'-0"

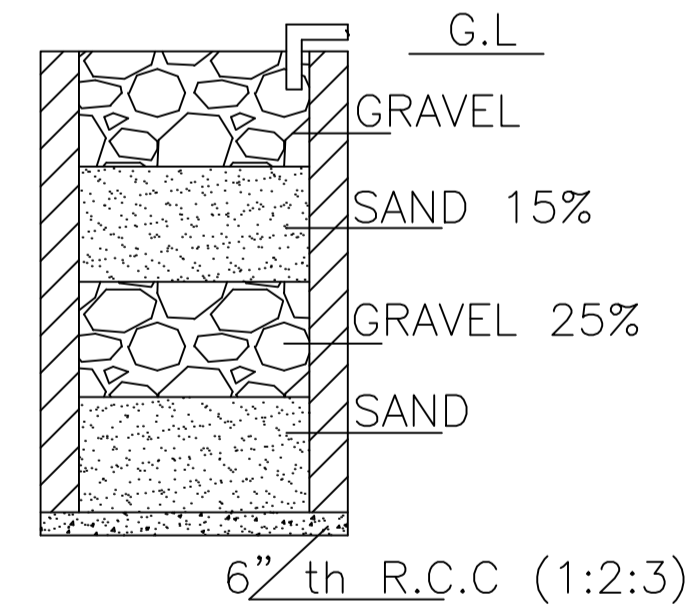

SECTION ON A - B

DETAILS DRAWING OF
RAIN WATER HARVESTING
SCALE:- 1"=2'-0"

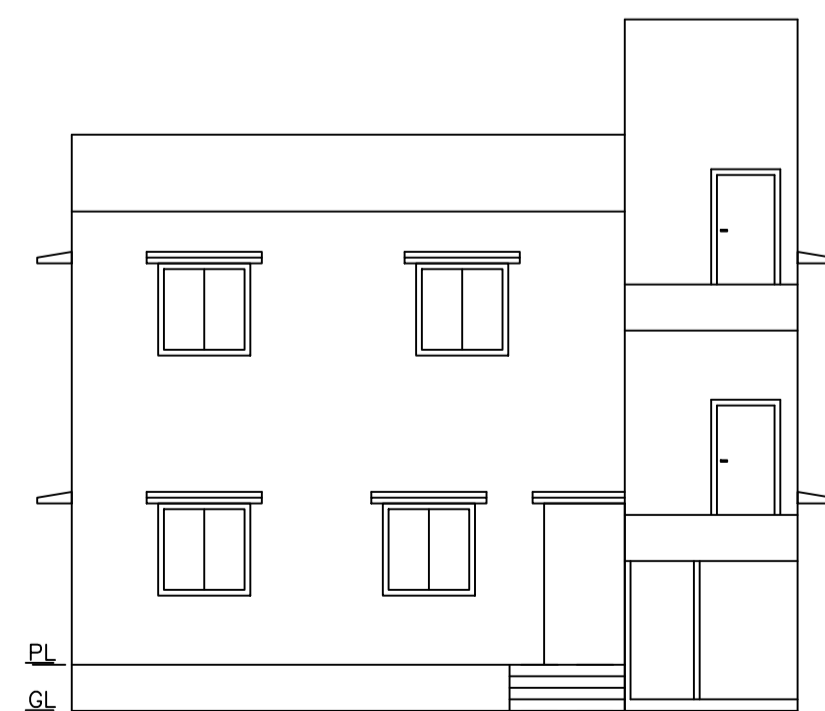

FRONT ELEVATION
SCALE - 1" = 8'-0"

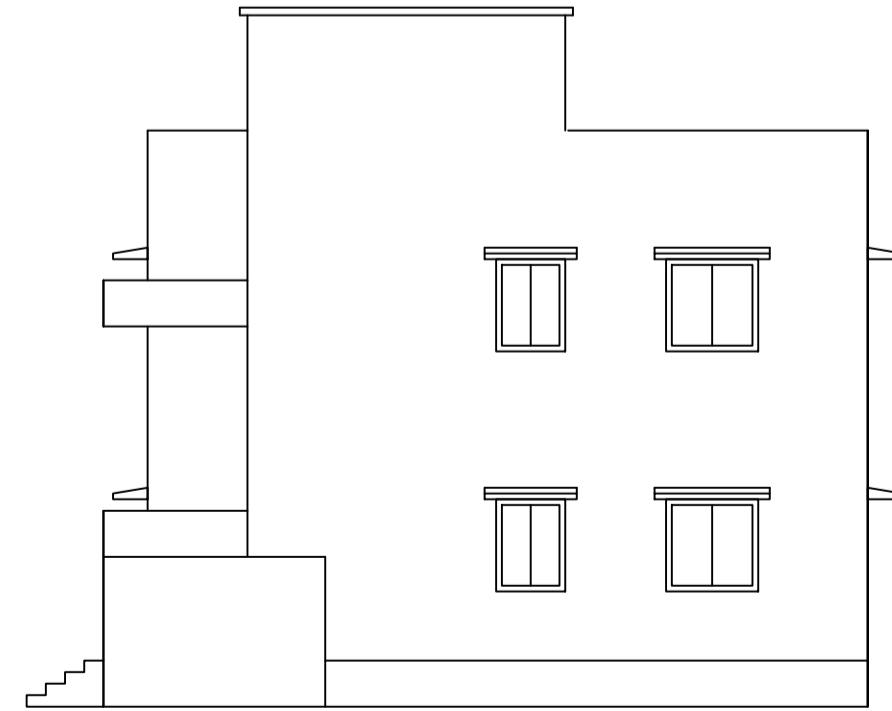

RIGHT SIDE ELEVATION
SCALE - 1" = 8'-0"

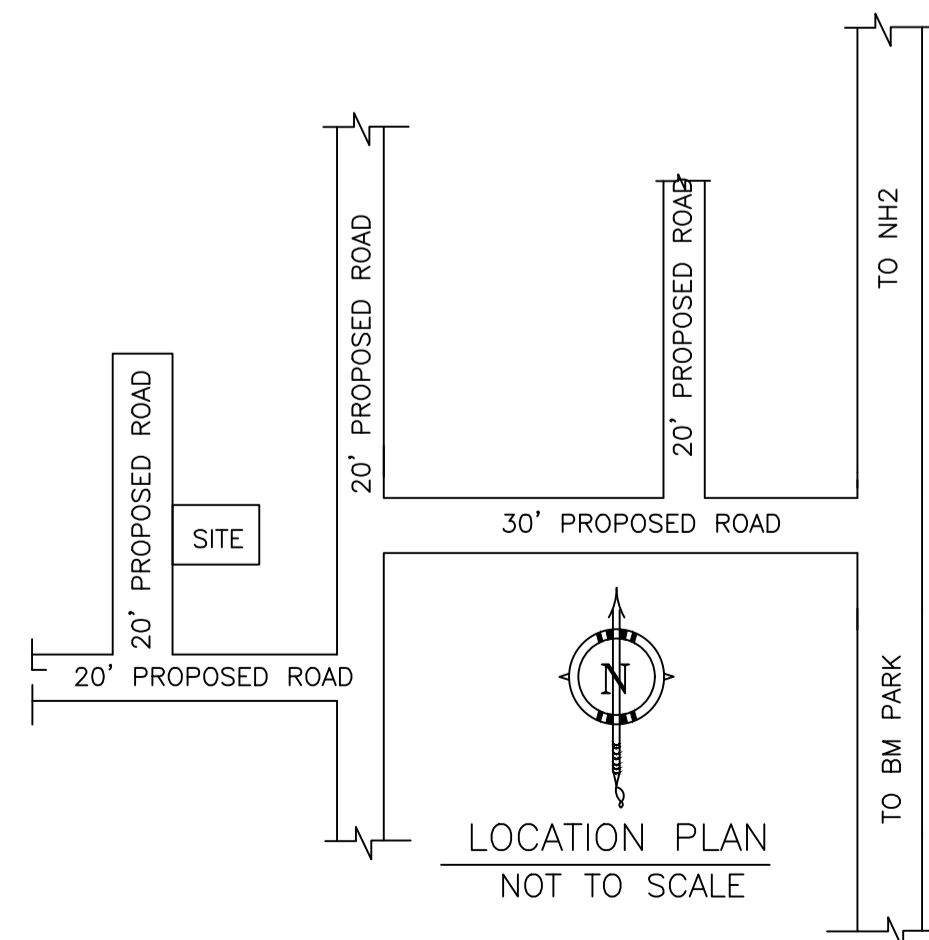

LOCATION PLAN
NOT TO SCALE

LTP NAME AND SIGNATURE	STRUCTURAL ENG'S NAME AND SIGNATURE	BUILDER NAME AND SIGNATURE	DIGITAL SIGNATURE
RAM PRATAP SINGH MADA/ARC/0024/2019			